

## Model 4619 Mounting Base Double Banana Jack & Binding Post, Miniature

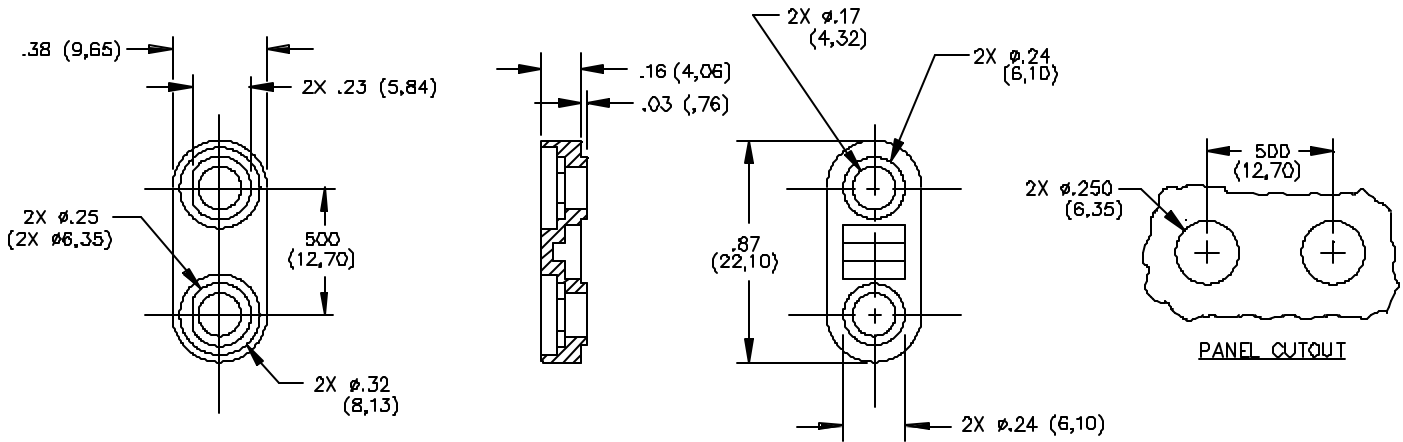

### MATERIALS:

Body: Polycarbonate

Color: Black and Red

Marking : Pomona Electronics Calif.

### RATINGS:

Operating Temperature: +115° C. (+239° F.) Max.

### ORDERING INFORMATION: 4619-\*

\*=Color, -0 Black, -2 Red

Ordering Example: 4619-2 Mounting Base Color is Red

Parts are packaged ten (10) per bag.

For use with Models 2142, 2143, 2382, 2383, 2439,2440, 3542, 4022, 4773 and 4543.

All dimensions are in inches. Tolerances (except noted): .xx = ±.02" (.51 mm), .xxx = ± .005" (.127 mm).

All specifications are to the latest revisions. Specifications are subject to change without notice.

Registered trademarks are the property of their respective companies. Made in USA

# Mouser Electronics

Authorized Distributor

Click to View Pricing, Inventory, Delivery & Lifecycle Information:

[Pomona:](#)

[4619-2](#)