



MICROCHIP

MCP4XXX Digital Potentiometer Daughter Board User's Guide

Note the following details of the code protection feature on Microchip devices:

- Microchip products meet the specification contained in their particular Microchip Data Sheet.
- Microchip believes that its family of products is one of the most secure families of its kind on the market today, when used in the intended manner and under normal conditions.
- There are dishonest and possibly illegal methods used to breach the code protection feature. All of these methods, to our knowledge, require using the Microchip products in a manner outside the operating specifications contained in Microchip's Data Sheets. Most likely, the person doing so is engaged in theft of intellectual property.
- Microchip is willing to work with the customer who is concerned about the integrity of their code.
- Neither Microchip nor any other semiconductor manufacturer can guarantee the security of their code. Code protection does not mean that we are guaranteeing the product as "unbreakable."

Code protection is constantly evolving. We at Microchip are committed to continuously improving the code protection features of our products. Attempts to break Microchip's code protection feature may be a violation of the Digital Millennium Copyright Act. If such acts allow unauthorized access to your software or other copyrighted work, you may have a right to sue for relief under that Act.

Information contained in this publication regarding device applications and the like is provided only for your convenience and may be superseded by updates. It is your responsibility to ensure that your application meets with your specifications. MICROCHIP MAKES NO REPRESENTATIONS OR WARRANTIES OF ANY KIND WHETHER EXPRESS OR IMPLIED, WRITTEN OR ORAL, STATUTORY OR OTHERWISE, RELATED TO THE INFORMATION, INCLUDING BUT NOT LIMITED TO ITS CONDITION, QUALITY, PERFORMANCE, MERCHANTABILITY OR FITNESS FOR PURPOSE. Microchip disclaims all liability arising from this information and its use. Use of Microchip devices in life support and/or safety applications is entirely at the buyer's risk, and the buyer agrees to defend, indemnify and hold harmless Microchip from any and all damages, claims, suits, or expenses resulting from such use. No licenses are conveyed, implicitly or otherwise, under any Microchip intellectual property rights.

Trademarks

The Microchip name and logo, the Microchip logo, Accuron, dsPIC, KEELOQ, microID, MPLAB, PIC, PICmicro, PICSTART, PRO MATE, PowerSmart, rfPIC and SmartShunt are registered trademarks of Microchip Technology Incorporated in the U.S.A. and other countries.

AmpLab, FilterLab, Migratable Memory, MXDEV, MXLAB, SEEVAL, SmartSensor and The Embedded Control Solutions Company are registered trademarks of Microchip Technology Incorporated in the U.S.A.

Analog-for-the-Digital Age, Application Maestro, CodeGuard, dsPICDEM, dsPICDEM.net, dsPICworks, ECAN, ECONOMONITOR, FanSense, FlexROM, fuzzyLAB, In-Circuit Serial Programming, ICSP, ICEPIC, Linear Active Thermistor, Mindi, MiWi, MPASM, MPLIB, MPLINK, PICKIT, PICDEM, PICDEM.net, PICLAB, PICTail, PowerCal, PowerInfo, PowerMate, PowerTool, REAL ICE, rFLAB, rfPICDEM, Select Mode, Smart Serial, SmartTel, Total Endurance, UNI/O, WiperLock and ZENA are trademarks of Microchip Technology Incorporated in the U.S.A. and other countries.

SQTP is a service mark of Microchip Technology Incorporated in the U.S.A.

All other trademarks mentioned herein are property of their respective companies.

© 2006, Microchip Technology Incorporated, Printed in the U.S.A., All Rights Reserved.

 Printed on recycled paper.

QUALITY MANAGEMENT SYSTEM
CERTIFIED BY DNV
== ISO/TS 16949:2002 ==

Microchip received ISO/TS-16949:2002 certification for its worldwide headquarters, design and wafer fabrication facilities in Chandler and Tempe, Arizona, Gresham, Oregon and Mountain View, California. The Company's quality system processes and procedures are for its PICmicro® 8-bit MCUs, KEELOQ® code hopping devices, Serial EEPROMs, microperipherals, nonvolatile memory and analog products. In addition, Microchip's quality system for the design and manufacture of development systems is ISO 9001:2000 certified.



MCP4XXX DIGITAL POTENTIOMETER DAUGHTER BOARD USER'S GUIDE

Table of Contents

Preface	1
Chapter 1. Product Overview	5
1.1 Introduction	5
1.2 What is the MCP4XXX Digital Potentiometer Daughter Board?	5
1.3 What the MCP4XXX Digital Potentiometer Daughter Board Kit Includes	6
Chapter 2. Installation and Operation	7
2.1 Introduction	7
2.2 Features	7
2.3 Getting Started	8
2.4 MCP4XXX Digital Potentiometer Daughter Board Description	16
2.5 Demo with PICDEM Demo Board	17
Appendix A. Schematics and Layouts	23
A.1 Introduction	23
A.2 Schematics and PCB Layout	23
A.3 Board Schematic - Digital Circuitry	24
A.4 Top Layer And Silk Screen	25
A.5 Top Layer	26
A.6 Bottom Layer	27
A.7 Top Components And Silk Screen	28
Appendix B. Bill Of Materials (BOM)	29
Appendix C. Board Testing	31
C.1 What is Tested	32
C.2 What is NOT Tested	32
Worldwide Sales and Service	34

MCP4XXX Digital Potentiometer Daughter Board User's Guide

NOTES:



MCP4XXX DIGITAL POTENTIOMETER DAUGHTER BOARD USER'S GUIDE

Preface

NOTICE TO CUSTOMERS

All documentation becomes dated, and this manual is no exception. Microchip tools and documentation are constantly evolving to meet customer needs, so some actual dialogs and/or tool descriptions may differ from those in this document. Please refer to our web site (www.microchip.com) to obtain the latest documentation available.

Documents are identified with a "DS" number. This number is located on the bottom of each page, in front of the page number. The numbering convention for the DS number is "DSXXXXA", where "XXXX" is the document number and "A" is the revision level of the document.

For the most up-to-date information on development tools, see the MPLAB® IDE on-line help. Select the Help menu, and then Topics to open a list of available on-line help files.

INTRODUCTION

This chapter contains general information that will be useful to know before using the MCP4XXX Digital Potentiometer Daughter Board. Items discussed in this chapter include:

- Document Layout
- Conventions Used in this Guide
- Recommended Reading
- The Microchip Web Site
- Customer Support
- Document Revision History

DOCUMENT LAYOUT

This document describes how to use the MCP4XXX Digital Potentiometer Daughter Board. The manual layout is as follows:

- **Chapter 1. "Product Overview"** – Important information about the MCP4XXX Digital Potentiometer Daughter Board.
- **Chapter 2. "Installation and Operation"** – Includes instructions on how to get started with the MCP4XXX Digital Potentiometer Daughter Board.
- **Appendix A. "Schematics and Layouts"** – Shows the schematic and layout diagrams for the MCP4XXX Digital Potentiometer Daughter Board.
- **Appendix B. "Bill Of Materials (BOM)"** – Lists the parts used to build the MCP4XXX Digital Potentiometer Daughter Board.

MCP4XXX Digital Potentiometer Daughter Board User's Guide

CONVENTIONS USED IN THIS GUIDE

This manual uses the following documentation conventions:

DOCUMENTATION CONVENTIONS

Description	Represents	Examples
Arial font:		
Italic characters	Referenced books	<i>MPLAB[®] IDE User's Guide</i>
	Emphasized text	...is the <i>only</i> compiler...

RECOMMENDED READING

Table 1-1 shows the device and associated data sheet literature number. These documents can be downloaded from the Microchip web site at: www.microchip.com.

TABLE 1-1: DEVICES AND DATA SHEET LITERATURE NUMBERS

Device	Literature #		Device	Literature #
MCP4011	DS21978		MCP41010	DS11195
MCP4012	DS21978		MCP41050	DS11195
MCP4013	DS21978		MCP41100	DS11195
MCP4014	DS21978		MCP42010	DS11195
MCP4021	DS21945		MCP42050	DS11195
MCP4022	DS21945		MCP42100	DS11195
MCP4023	DS21945		—	—
MCP4024	DS21945		—	—

THE MICROCHIP WEB SITE

Microchip provides online support via our web site at www.microchip.com. This web site is used as a means to make files and information easily available to customers. Accessible by using your favorite Internet browser, the web site contains the following information:

- **Product Support** – Data sheets and errata, application notes and sample programs, design resources, user's guides and hardware support documents, latest software releases and archived software
- **General Technical Support** – Frequently Asked Questions (FAQs), technical support requests, online discussion groups, Microchip consultant program member listing
- **Business of Microchip** – Product selector and ordering guides, latest Microchip press releases, listing of seminars and events, listings of Microchip sales offices, distributors and factory representatives

CUSTOMER SUPPORT

Users of Microchip products can receive assistance through several channels:

- Distributor or Representative
- Local Sales Office
- Field Application Engineer (FAE)
- Technical Support
- Development Systems Information Line

Customers should contact their distributor, representative or field application engineer for support. Local sales offices are also available to help customers. A listing of sales offices and locations is included in the back of this document.

Technical support is available through the web site at: <http://support.microchip.com>.

DOCUMENT REVISION HISTORY

Revision A (July 2006)

- Initial Release of this Document.

MCP4XXX Digital Potentiometer Daughter Board User's Guide

NOTES:



MCP4XXX DIGITAL POTENTIOMETER DAUGHTER BOARD USER'S GUIDE

Chapter 1. Product Overview

1.1 INTRODUCTION

This chapter provides an overview of the MCP4XXX Digital Potentiometer Daughter Board and covers the following topics:

- What is the MCP4XXX Digital Potentiometer Daughter Board?
- What the MCP4XXX Digital Potentiometer Daughter Board kit includes

1.2 WHAT IS THE MCP4XXX DIGITAL POTENTIOMETER DAUGHTER BOARD?

The MCP4XXX Digital Potentiometer Daughter Board allows the system designer to quickly evaluate the operation of Microchip Technology's MCP42XXX and MCP4021 Digital Potentiometers. The MCP42XXX are dual Digital Potentiometer devices that have the same characteristics as their single Digital Potentiometer devices (MCP41XXX). The MCP4021 devices are non-volatile devices that have similar characteristics as their volatile memory versions (MCP4011). The board supports two MCP42XXX devices to allow the Resistor Networks to be "stacked" and form a programmable windowed Digital Potentiometer and an MCP4021 device, which can be replaced with an MCP4011 device. The board has one MCP42010 device (10 k Ω), which can be the rheostats at the ends, and one MCP42010 device (10 k Ω) which is the potentiometer in the middle and a separate standalone potentiometer.

The board also has an MCP4021-103 (10 k Ω) device for evaluation. The characteristics of this device is similar to the other MCP402X devices. The MCP4021 footprint (SOIC) is the same as the MCP4011 device. The MCP4021 can be removed and replaced with an MCP4011. The MCP4021 can be jumpered into the middle potentiometer configuration to compare the characteristics of the MCP42XXX device to the MCP4011/MCP4021 device.

The board also has a voltage doubler device (TC1240A), which can be used to show the WiperLock™ Technology feature of the MCP4021.

The MCP4XXX Digital Potentiometer Daughter Board has been made configurable, via jumpers. This allows you to determine the configuration that you wish to have the four digital potentiometer of the MCP42XXX devices.

Some of the features include:

- Header to interface to PICDEM™ boards using 28-pin header, including
 - PICDEM™ HPC Explorer Demo Board
 - PICDEM™ FS USB Demo Board
 - PICDEM™ 2 Plus Demo Board (Rev 5 or later)
 - PICDEM™ LCD
- TC1240A Voltage Doubler to generate V_{IHH} voltage for WiperLock Technology evaluation
- Jumpers for configuration of U1-Pot0, U2-Pot0, and U2-Pot1 terminal connections
- Jumpers for MCP4021 Pot (A, W, and B) to replace U1-Pot0 in desired circuit
- Jumpers for routing signals (SI, SO, SCK, and \overline{CS}) from either a PICDEM HPC Demo board or a PICDEM FS USB Demo Board
- Pads for easy connection to the Digital Potentiometer signals, including the Resistor Network Terminals and the Serial Interface signals

1.3 WHAT THE MCP4XXX DIGITAL POTENTIOMETER DAUGHTER BOARD KIT INCLUDES

This MCP4XXX Digital Potentiometer Daughter Board Kit includes:

- MCP4XXX Digital Potentiometer Daughter Board
- Analog and Interface Products Demonstration Boards CD-ROM (DS21912)
 - MCP4XXX Digital Potentiometer Daughter Board User's Guide



MCP4XXX DIGITAL POTENTIOMETER DAUGHTER BOARD USER'S GUIDE

Chapter 2. Installation and Operation

2.1 INTRODUCTION

This daughter board allows evaluation of digital potentiometer devices in different circuit configurations. The board supports the MCP42XXX devices and the MCP4011/MCP4021 devices.

This board is intended to be “plugged into” the 28-pin header of the PICDEM™ Demo Boards. The board may also be “jumpered” into a desired application circuit.

2.2 FEATURES

The MCP4XXX Digital Potentiometer Daughter Board has the following features:

- Header to interface to PICDEM™ boards using 28-pin header, including:
 - PICDEM™ HPC Explorer Demo Board
 - PICDEM™ FS USB Demo Board
 - PICDEM™ 2 Plus Demo Board (Rev 5 or later)
 - PICDEM™ LCD
- TC1240A Voltage Doubler to generate V_{IHH} voltage for WiperLock™ Technology evaluation
- Jumpers for configuration of U1-Pot0, U2-Pot0, and U2-Pot1 terminal connections
- Jumpers for MCP4021 Pot (A, W, and B) to replace U1-Pot0 in desired circuit
- Jumpers for routing signals (SI, SO, SCK, and \overline{CS}) from either a PICDEM HPC Demo board or a PICDEM FS USB Demo Board
- Pads for easy connection to the Digital Potentiometer signals, including the Resistor Network Terminals and the Serial Interface signals
- Connection terminals may be either through-hole or surface-mount

2.3 GETTING STARTED

The MCP4XXX Digital Potentiometer Daughter Board is a board that allows the Digital Potentiometer circuit to be configured in many forms for evaluation of the device. The Resistor Network Circuit is shown in Figure 2-1 and shows the possible configurations that the demo board supports.

The passive components use the surface-mount 805 package layout. Figure 2-2 shows the board circuit.

This demo board supports the following Microchip Digital Potentiometers devices:

- MCP42XXX
- MCP4021
- MCP4011

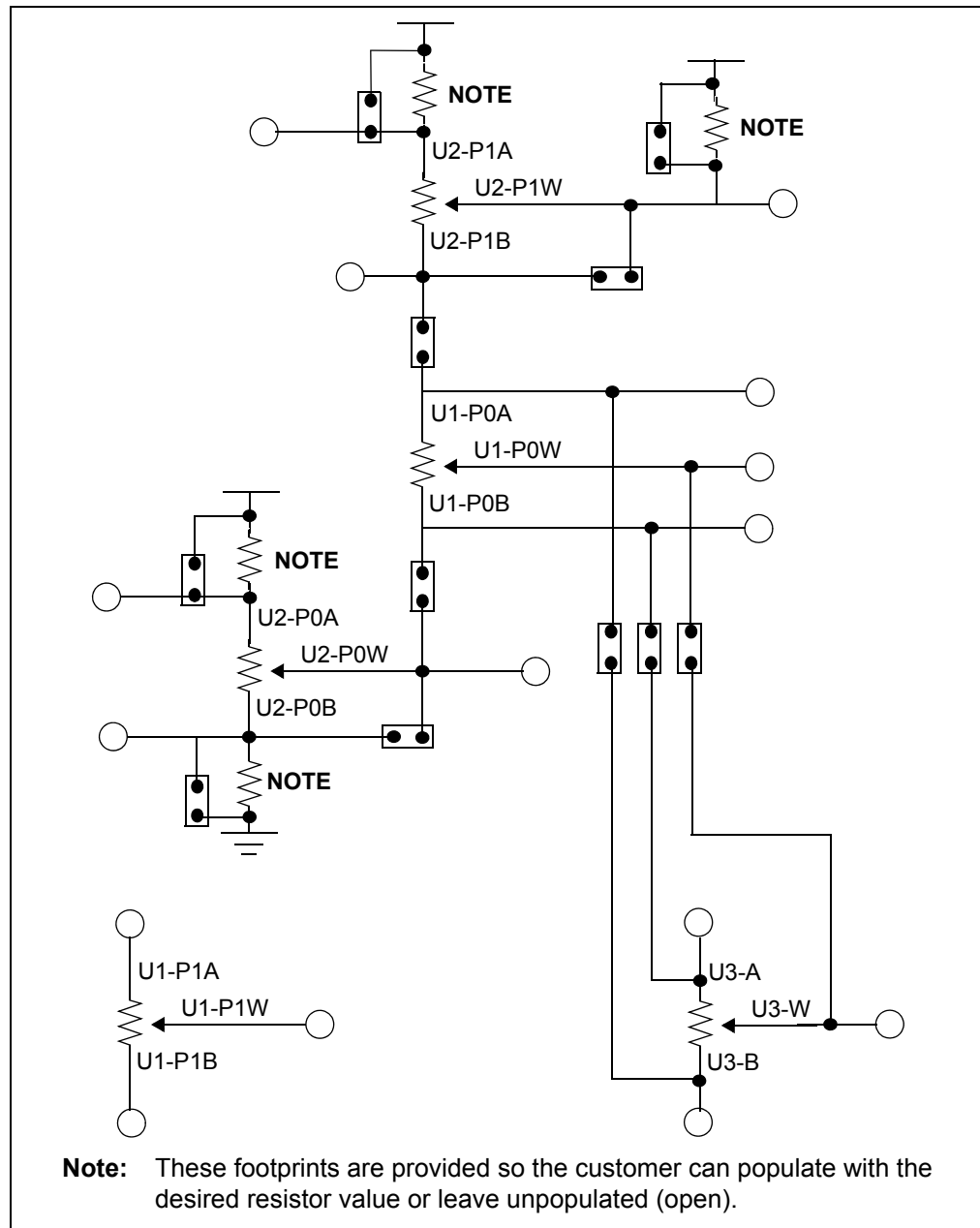

FIGURE 2-1: MCP4XXX Digital Potentiometer Daughter Board Resistor Network Circuit Configuration.

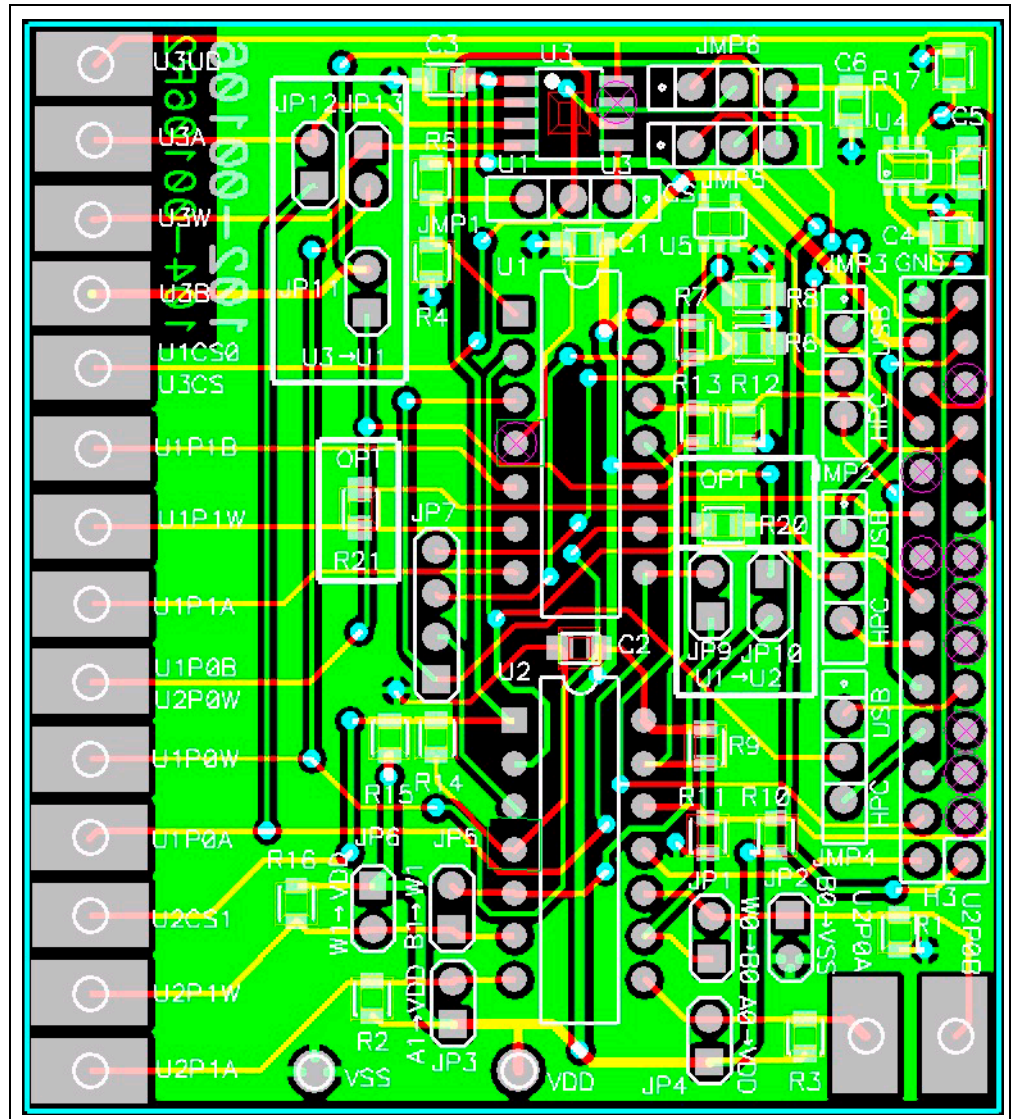

FIGURE 2-2: MCP4XXX Digital Potentiometer Daughter Board Circuit.

2.3.1 The Hardware

Figure 2-2 shows the layout of the MCP4XXX Digital Potentiometer Daughter Board. This is a small two-layer board (2.25" x 2.517" (57.2 mm x 63.9 mm)).

There are sixteen connection points/pads that can use either through-hole or surface-mount connector posts and two through hole connections for power/ground. The connections to the SPI signals can be via the center taps of the JMP2 (SCK/SCL), JMP3 (SDO), and JMP4 (SDI/SDA) jumpers.

2.3.1.1 JUMPERS

Figure 2-3 through Figure 2-6 show the function of the demo board jumpers. Some of the jumpers configure the interface connections, while other configure the resistor network configuration.

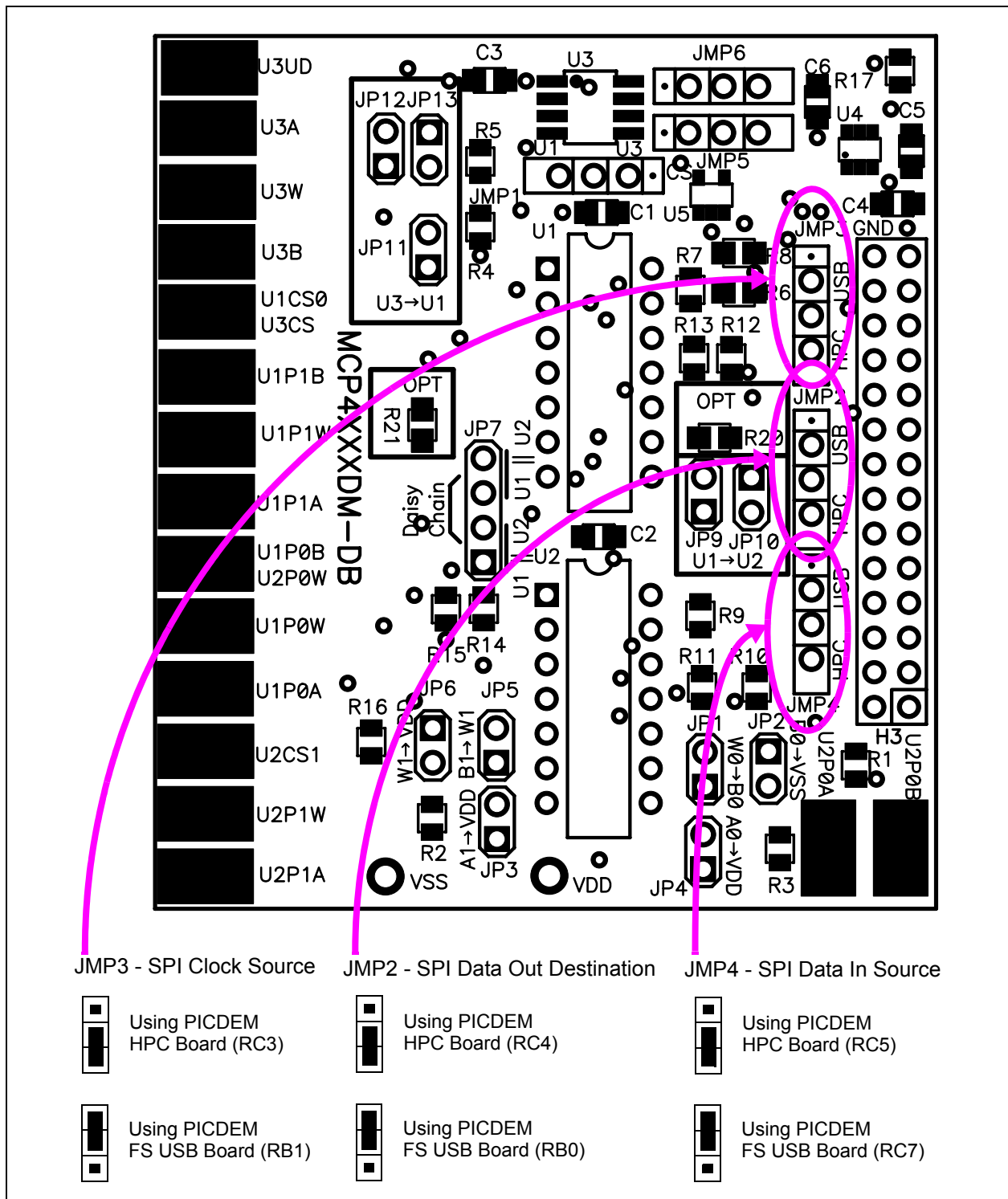

FIGURE 2-3: Jumper JMP2, JMP3, and JMP4 Configurations.

MCP4XXX Digital Potentiometer Daughter Board User's Guide

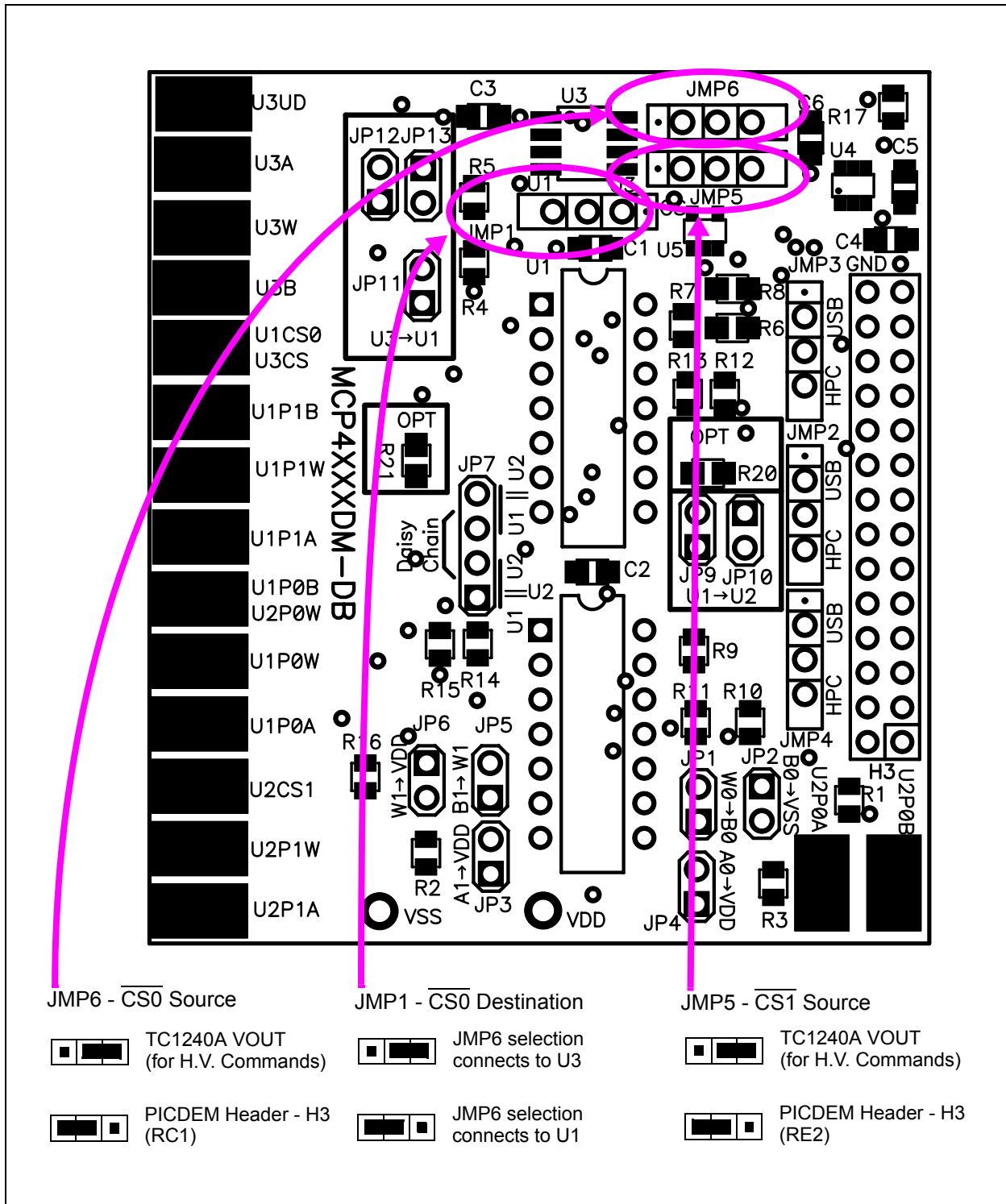

FIGURE 2-4: Jumper JMP1, JMP5, and JMP6 Configurations.

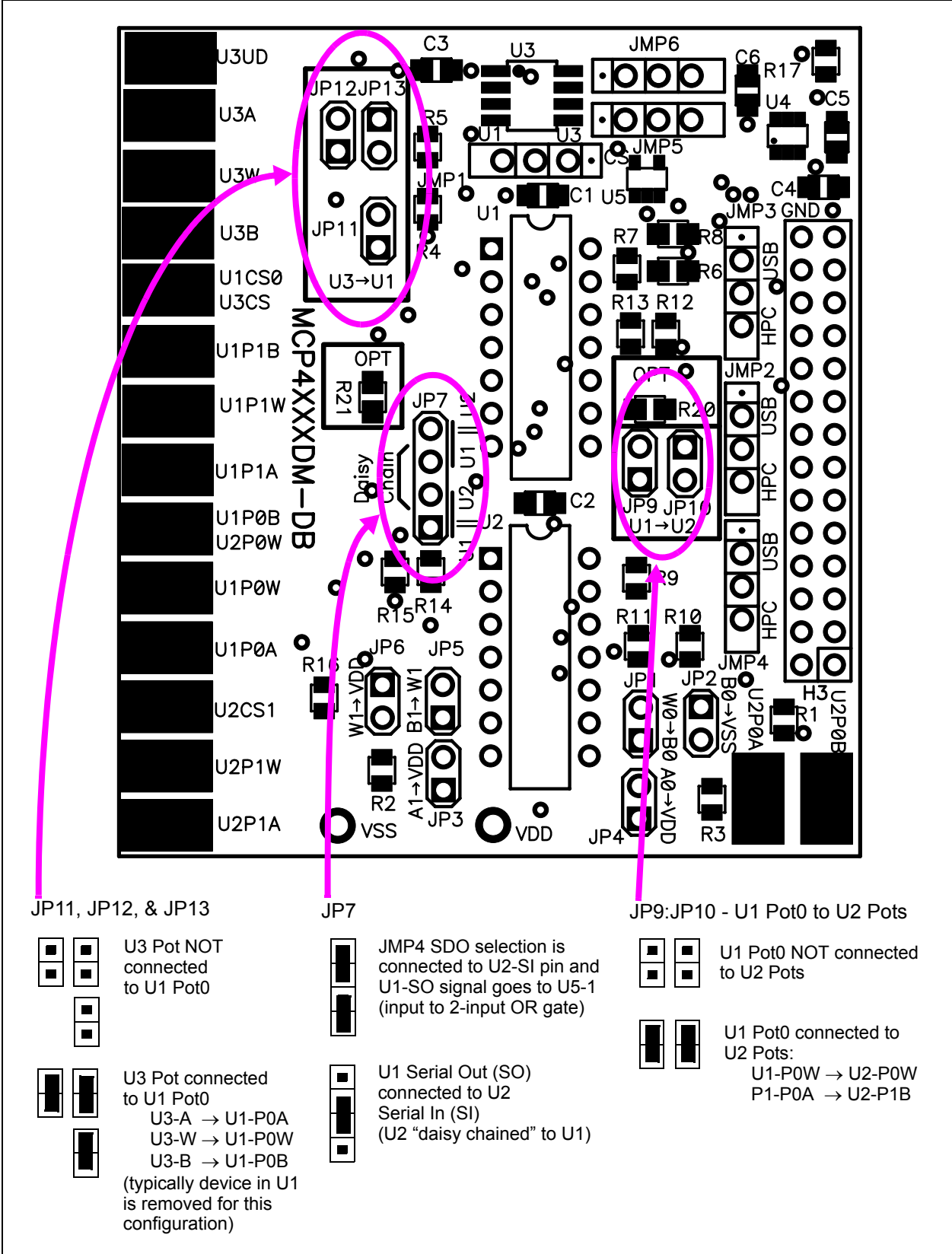
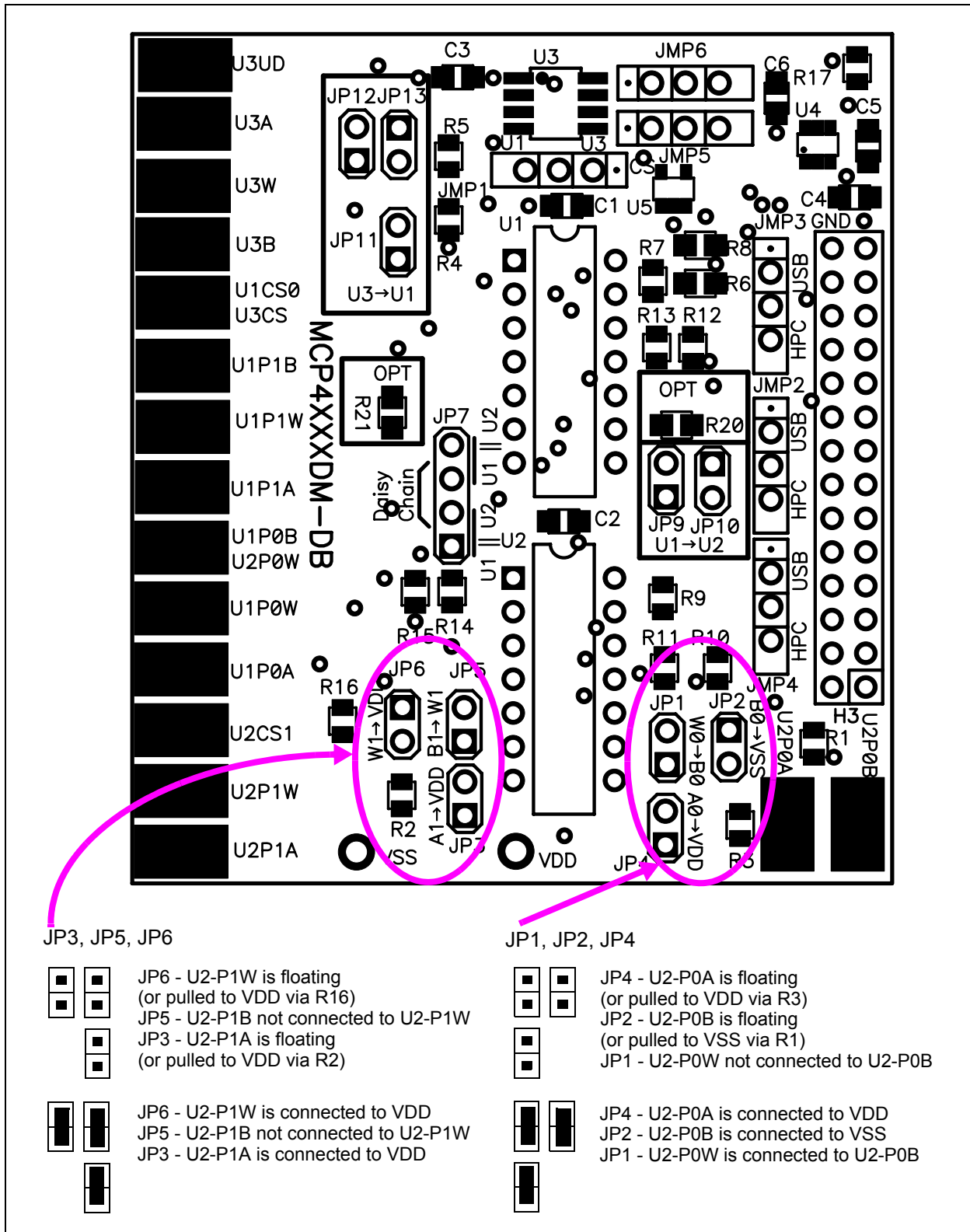
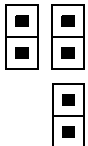

FIGURE 2-5: Jumper JP7, JP9, JP10, JP11, JP12, and JP13 Configurations.



JP3, JP5, JP6



JP6 - U2-P1W is floating
(or pulled to VDD via R16)
JP5 - U2-P1B not connected to U2-P1W
JP3 - U2-P1A is floating
(or pulled to VDD via R2)

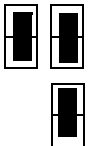

JP6 - U2-P1W is connected to VDD
JP5 - U2-P1B not connected to U2-P1W
JP3 - U2-P1A is connected to VDD

JP1, JP2, JP4

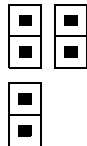

JP4 - U2-P0A is floating
(or pulled to VDD via R3)
JP2 - U2-P0B is floating
(or pulled to VSS via R1)
JP1 - U2-P0W not connected to U2-P0B

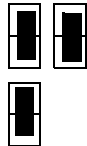

JP4 - U2-P0A is connected to VDD
JP2 - U2-P0B is connected to VSS
JP1 - U2-P0W is connected to U2-P0B

FIGURE 2-6: Jumper JP1, JP2, JP3, JP4, JP5, and JP6 Configurations.

2.3.1.2 PASSIVE COMPONENTS

Table 2-1 shows the optional passive components (resistors) that are by default not populated. Use the schematic to determine which resistors and values are required for your custom configuration.

TABLE 2-1: OPTIONAL PASSIVE COMPONENTS

Device	Comment
R2, R3, R5, R7, R9, R10, R13, R15, R16	Pull-up resistor
R1, R4, R11, R12, R14	Pull-down resistor
R20, R21	In-line resistor. Connected between the U1 wiper outputs and the PICDEM 28-pin header (H3) A/D pins. This is default open due to the PICDEM Demo Boards may have circuitry on these pins which would effect the wiper operation. If these are installed (typically with a 0 Ω resistor), ensure that the PICDEM board has been appropriately modified so that the wiper signal is not effected.

MCP4XXX Digital Potentiometer Daughter Board User's Guide

2.4 MCP4XXX DIGITAL POTENTIOMETER DAUGHTER BOARD DESCRIPTION

The MCP4XXX Digital Potentiometer Daughter Board PCB is designed to be flexible in the type of device evaluation that can be implemented.

The following sections describe each element of this evaluation board in further detail.

2.4.1 Power and Ground

The MCP4XXX Digital Potentiometer Daughter Board receives its power over the J3 header connector. If the board is to be jumpered into an existing application, then the board can have connection posts installed for the power (V_{DD}) and ground (V_{SS}), which are located below device U2. The layout allows through-hole connection posts.

2.4.2 Connection Pads

The MCP4XXX Digital Potentiometer Daughter Board has pads for all the resistor network signal. These are:

U1-P0A U1-P0W U1-P0B	Socket U1	Potentiometer 0
U1-P01A U1-P1W U1-P1B	Socket U1	Potentiometer 1
U2-P0A U2-P0W U2-P0B	Socket U2	Potentiometer 0
U2-P01A U2-P1W U2-P1B	Socket U2	Potentiometer 1
U3-1A U3-W U3-B	Socket U3	Device only contains single Potentiometer

There are three pads for control signals that are also available:

- U1-CS0/U3-CS
- U2-CS1
- U3-UD

2.4.3 Passive Components (R1, R2, R3, R4, R5, R6, R7, R8, R9, R10, R11, R12, R13, R14, R15 and R16)

The footprints for these components are present to allow flexibility in the use of fixed resistors for the windowing of the U1-Pot0 (or U3-Pot) to better match your system requirements.

Resistors Used	Jumpers Required	Device Configuration	Comments
R1 & R3	—	U2-Pot0 is windowed	
R2 & R16	—	U2-Pot1 is windowed	
R1 & R2	JP1, JP5, JP9, & JP10	U1-Pot0 is windowed	
R1 & R16	—	U2-Rheo0 Trims R1 U2-Rheo1 Trims R16 U1-Pot0 is windowed	

2.5 DEMO WITH PICDEM DEMO BOARD

There is one demo for this daughter board. The demo has an assembly versions for the PICDEM HPC Explorer Demo Board and the PICDEM FS USB Demo Board.

The following hardware is required for this demo:

- PC with MPLAB-IDE installed
- ICD 2
- PICDEM HPC Explorer Demo Board (and power supply)
- 4 Channel oscilloscope

Note: An oscilloscope with fewer channels can be used, but this will reduce the information that can be displayed.

Figure 2-7 shows the Resistor Network circuit configuration for the demo. To create this circuit, the Jumper configuration and oscilloscope connection points for the demo are shown in Figure 2-8.

The output waveform is shown in Figure 2-10. For this waveform, the U1-Pot0 is windowed by forcing U2-Pot0 and U2-Pot1 to mid-scale. The Wiper (U1-P0W) is loaded with values to create a Triangle waveform. U1-Pot1 is connected to Power and Ground, and the Wiper (U1-P1W) is loaded with values to create an inverse Triangle waveform.

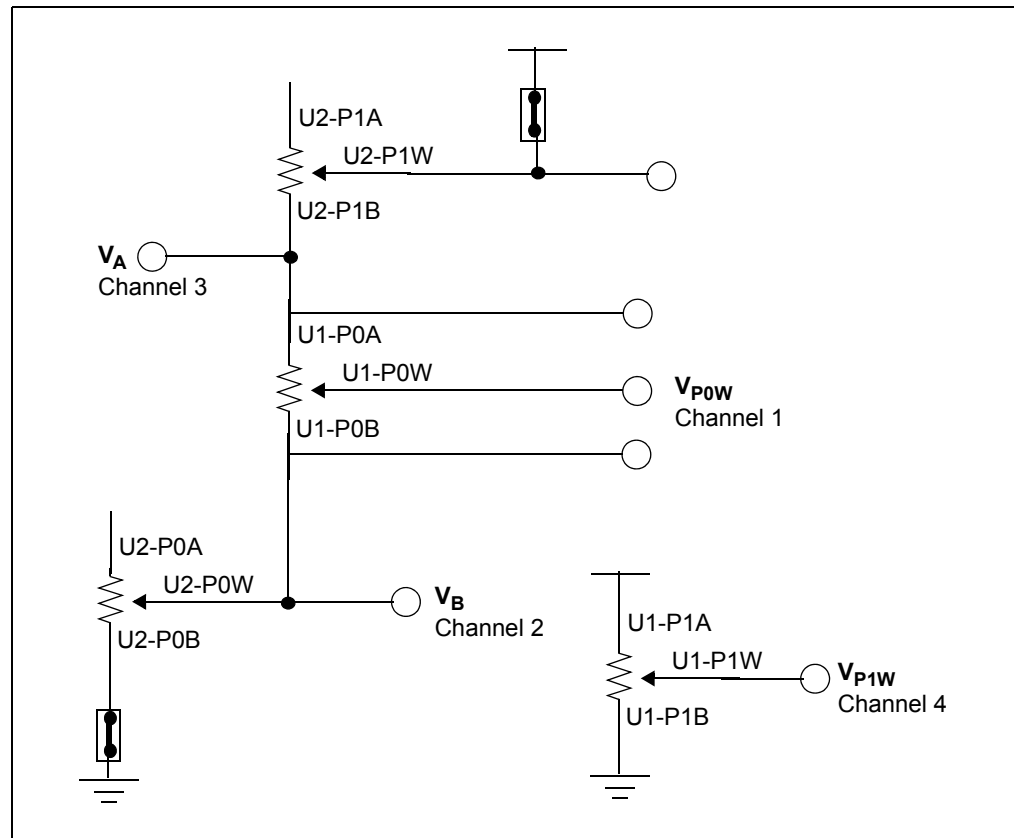

FIGURE 2-7: Demo Resistor Network Circuit Configuration.

MCP4XXX Digital Potentiometer Daughter Board User's Guide

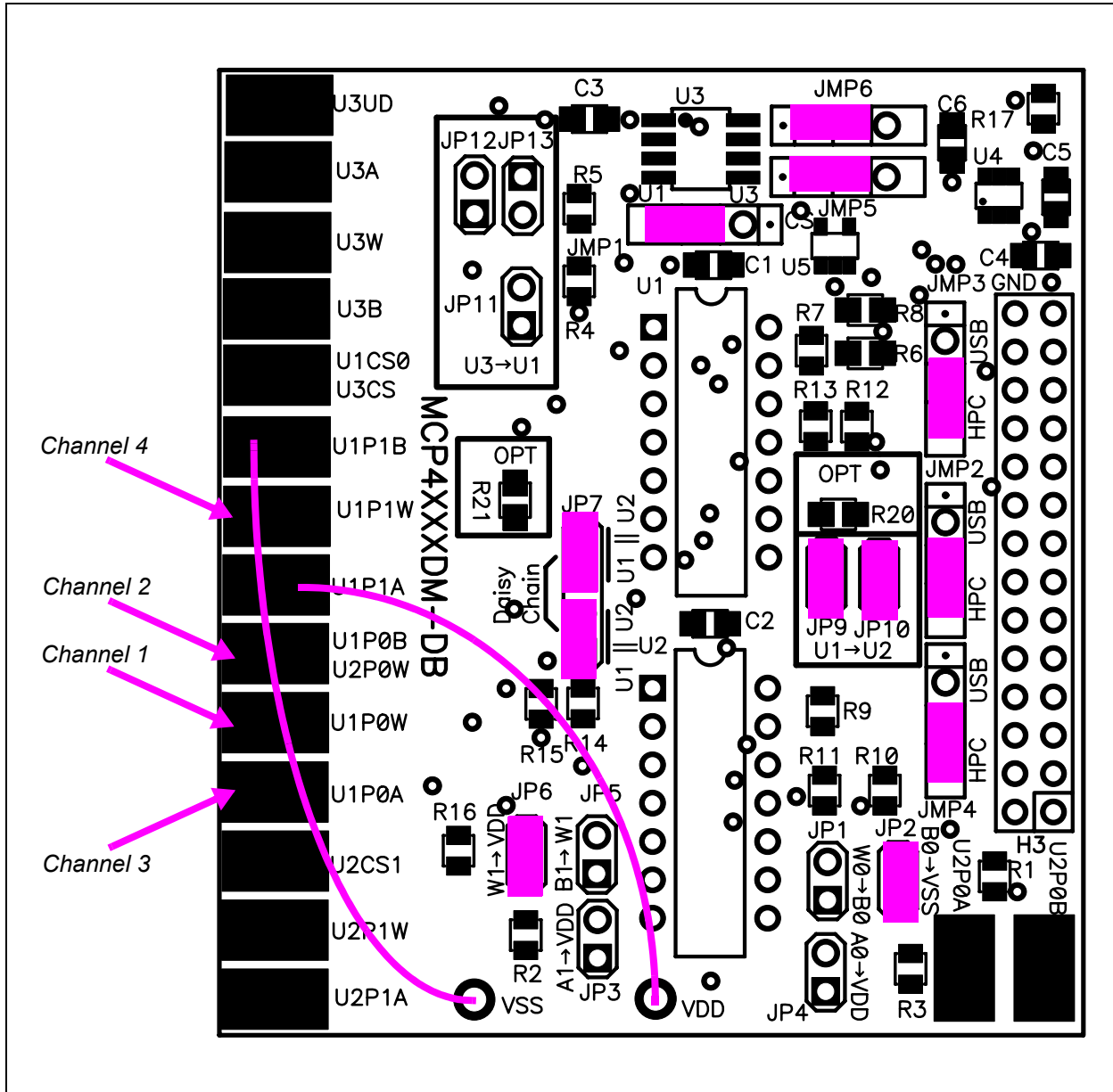

FIGURE 2-8: Demo Jumper Configuration for use with PICDEM HPC Explorer Demo Board.

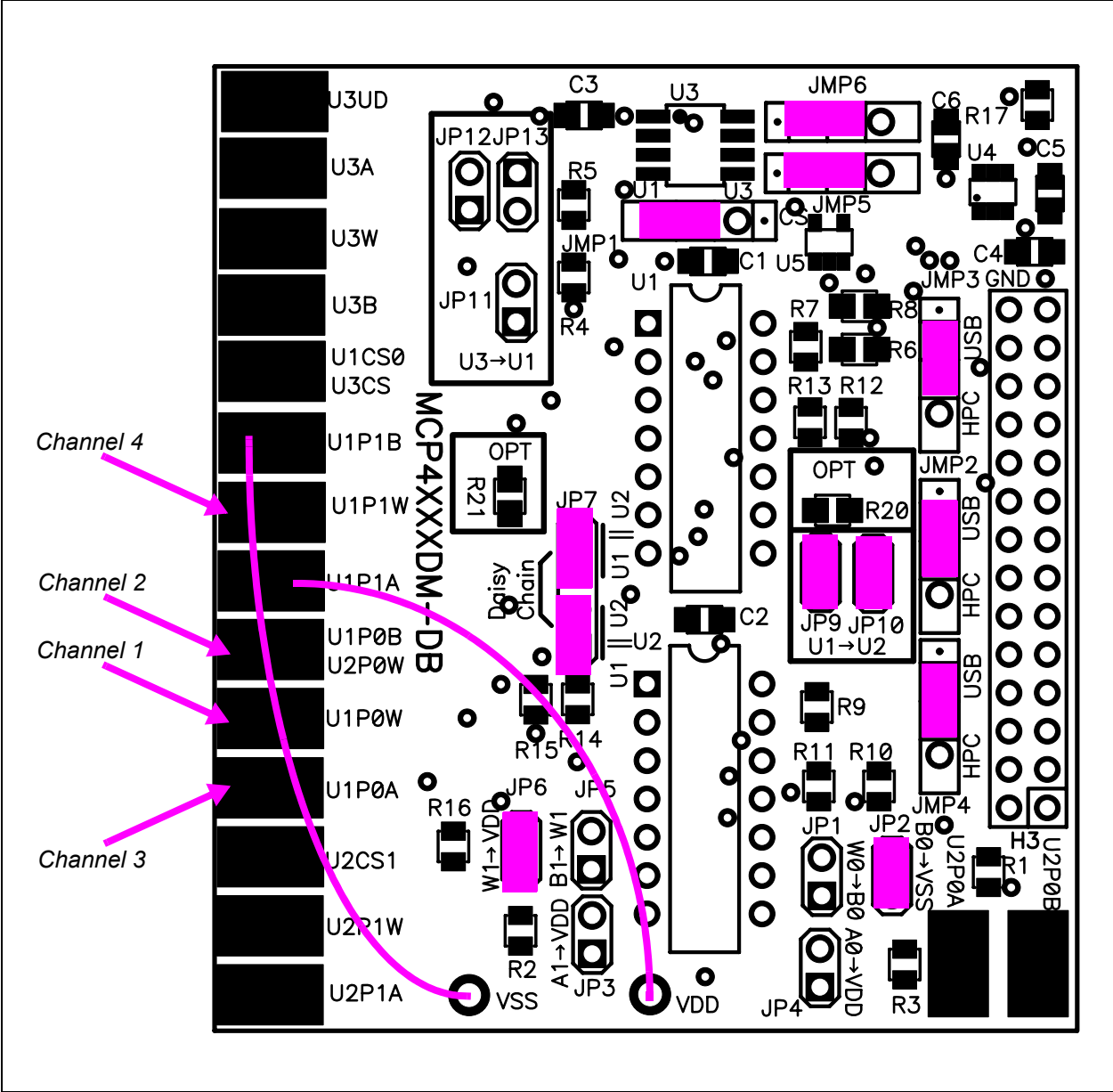

FIGURE 2-9: Demo Jumper Configuration for use with PICDEM FS USB Demo Board.

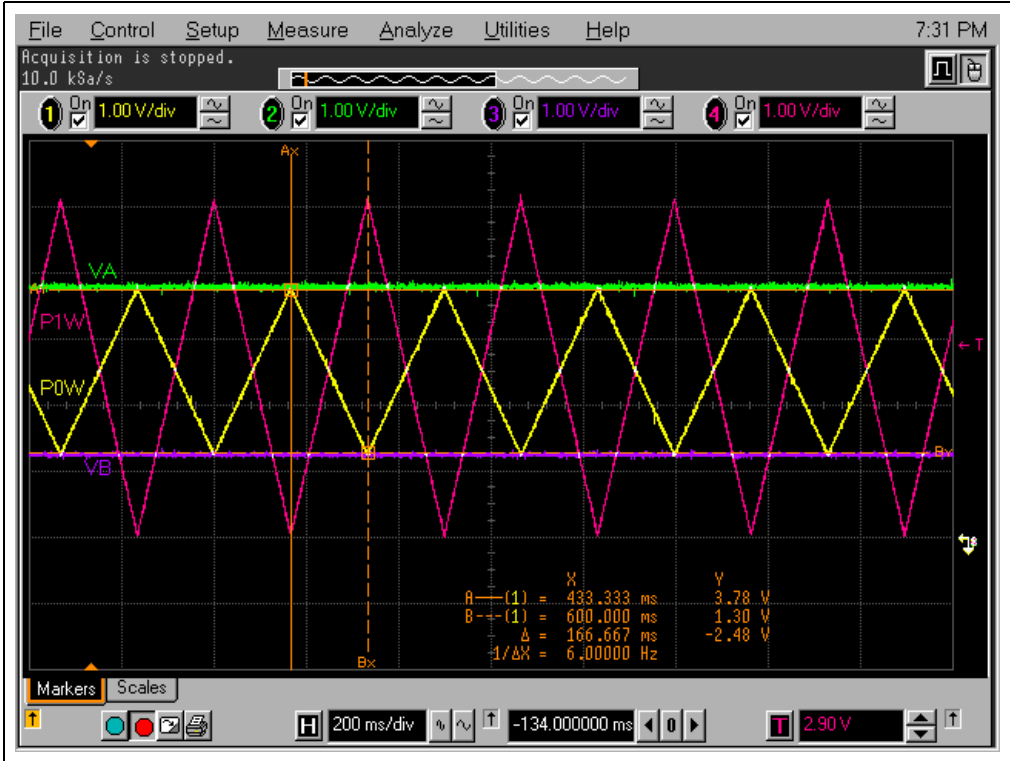

FIGURE 2-10: Screen Capture of P0W and P1W Output Waveforms.

2.5.1 Using the PICDEM HPC Explorer Demo Board

Note: For information on how to use MPLAB-IDE, ICD 2, or any other aspect of the PICmicro Development tool platform, please refer to the appropriate documentation.

Table 2-2 shows the sequence of steps to demonstrate the MCP4XXXDM-DB board (as shipped) with the PICDEM HPC Explorer Demo Board.

TABLE 2-2: DEMO STEPS FOR THE PICDEM HPC EXPLORER DEMO BOARD

Step	Action	Result
1	Connect ICD 2 to the PC and to the PICDEM HPC Explorer Demo Board	—
2	Power up and program the PICDEM HPC Explorer Demo Board with the file "00106 - HPC.hex"	—
3	Disconnect the ICD 2 from the PICDEM HPC Explorer Demo Board	PICDEM HPC Explorer Demo Board program should now be operating
4	Configure the MCP4XXXDM-DB to the jumper settings shown in Figure 2-8.	—
5	Insert the MCP4XXXDM-DB board into the PICDEM HPC Explorer Demo Board J3 header. Ensure proper orientation of Daughter Board to J3 Header. Note: You may be required to solder a 28-pin Female header into the J3 header socket.	—
6	Connect U1-P1A to the V_{DD} connection post and U1-P1B to the V_{SS} connection post.	—
7	Turn on oscilloscope and configure as follows: <ul style="list-style-type: none"> • Channel 1 to 4 @ 1V/Division • Channel 1 to 4 have same ground reference point • Time-base = 200 ms/Division 	—
8	Connect the oscilloscope probes as follows: <ul style="list-style-type: none"> • Channel 1 to the U1-P0W Pad • Channel 2 to the U1-P1A Pad • Channel 3 to the U1-P1B Pad • Channel 4 to the U1-P1W Pad 	Output waveform should look similar to Figure 2-10.

MCP4XXX Digital Potentiometer Daughter Board User's Guide

2.5.2 Using the PICDEM FS USB Demo Board

Note: For information on how to use MPLAB-IDE, ICD 2, or any other aspect of the PICmicro Development tool platform, please refer to the appropriate documentation.

Table 2-3 shows the sequence of steps to demonstrate the MCP4XXXDM-DB board (as shipped) with the PICDEM FS USB Demo Board.

TABLE 2-3: DEMO STEPS FOR THE PICDEM FS USB DEMO BOARD

Step	Action	Result
1	Connect ICD 2 to the PC and to the PICDEM FS USB Demo Board	—
2	Power up and program the PICDEM FS USB Demo Board with the file "00106 - FS USB.hex"	—
3	Disconnect the ICD 2 from the PICDEM FS USB Demo Board	PICDEM FS USB Demo Board program should now be operating
4	Configure the MCP4XXXDM-DB to the jumper settings shown in Figure 2-9.	—
5	Insert the MCP4XXXDM-DB board into the PICDEM FS USB Demo Board J6 header. Ensure proper orientation of Daughter Board to J6 Header. Note: You may be required to solder a 28-pin Female header into the J6 header socket.	—
6	Connect U1-P1A to the V_{DD} connection post and U1-P1B to the V_{SS} connection post.	—
7	Turn on oscilloscope and configure as follows: <ul style="list-style-type: none">• Channel 1 to 4 @ 1V/Division• Channel 1 to 4 have same ground reference point• Time-base = 200 ms/Division	—
8	Connect the oscilloscope probes as follows: <ul style="list-style-type: none">• Channel 1 to the U1-P0W Pad• Channel 2 to the U1-P1A Pad• Channel 3 to the U1-P1B Pad• Channel 4 to the U1-P1W Pad	Output waveform should look similar to Figure 2-10.



MCP4XXX DIGITAL POTENTIOMETER DAUGHTER BOARD USER'S GUIDE

Appendix A. Schematics and Layouts

A.1 INTRODUCTION

This appendix contains the schematics and layouts for the MCP4XXX Digital Potentiometer Daughter Board. Diagrams included in this appendix:

- Board Schematic - Digital Circuitry
- Board - Top Layer

A.2 SCHEMATICS AND PCB LAYOUT

Figure A.3 shows the schematic of the MCP4XXX Digital Potentiometer Daughter Board.

Figure A.4 shows the layout for the top layer of the MCP4XXX Digital Potentiometer Daughter Board. The layer order is shown in Figure A-1.

FIGURE A-1: LAYER ORDER

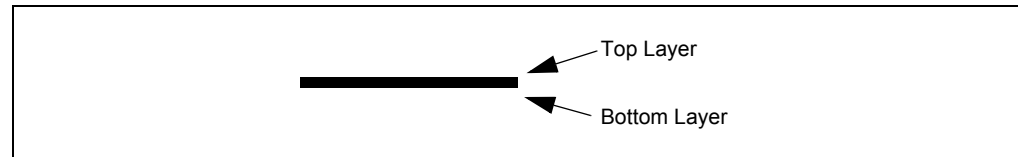

MCP4XXX Digital Potentiometer Daughter Board User's Guide

A.3 BOARD SCHEMATIC - DIGITAL CIRCUITRY

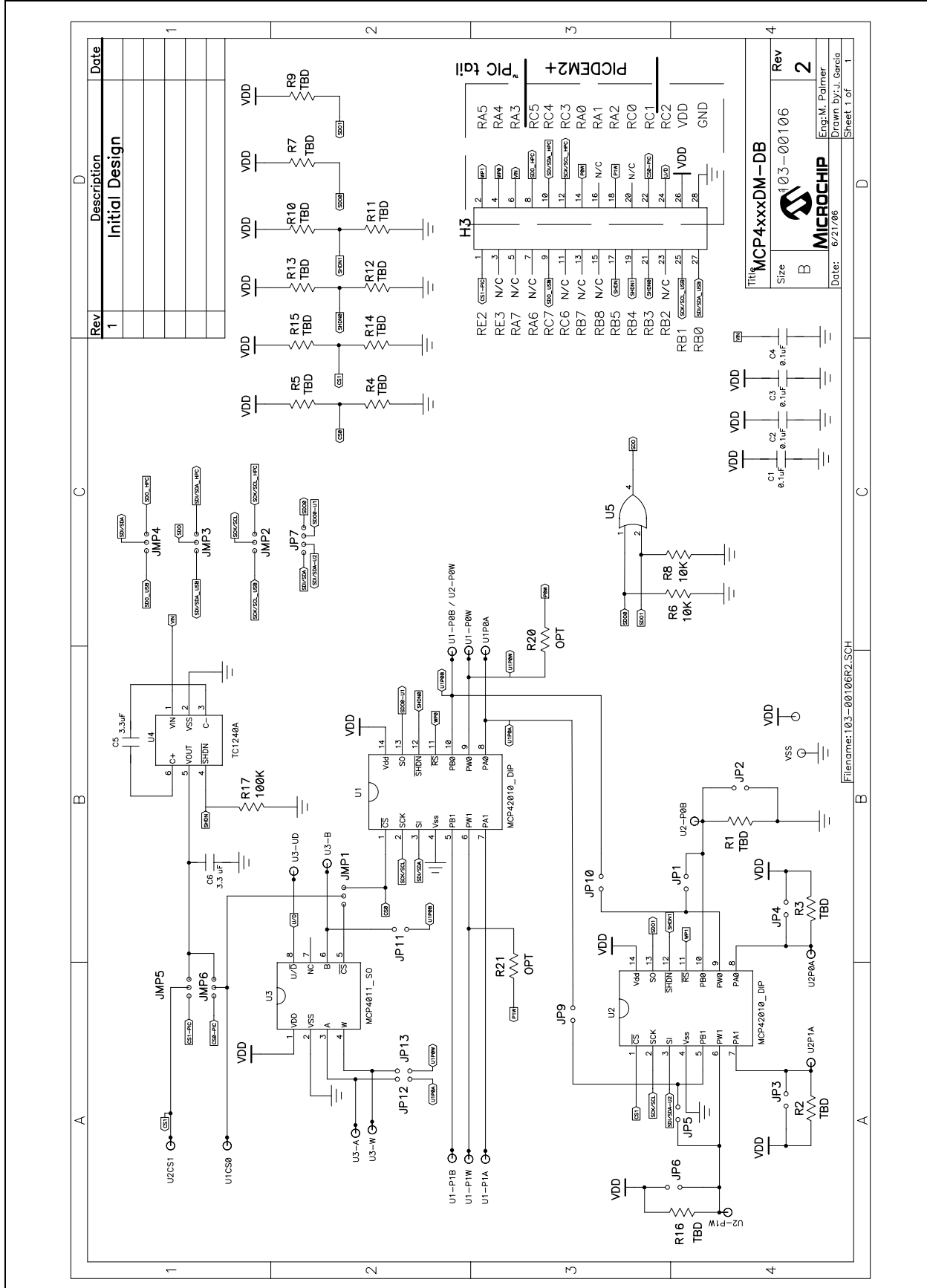

A.4 TOP LAYER AND SILK SCREEN

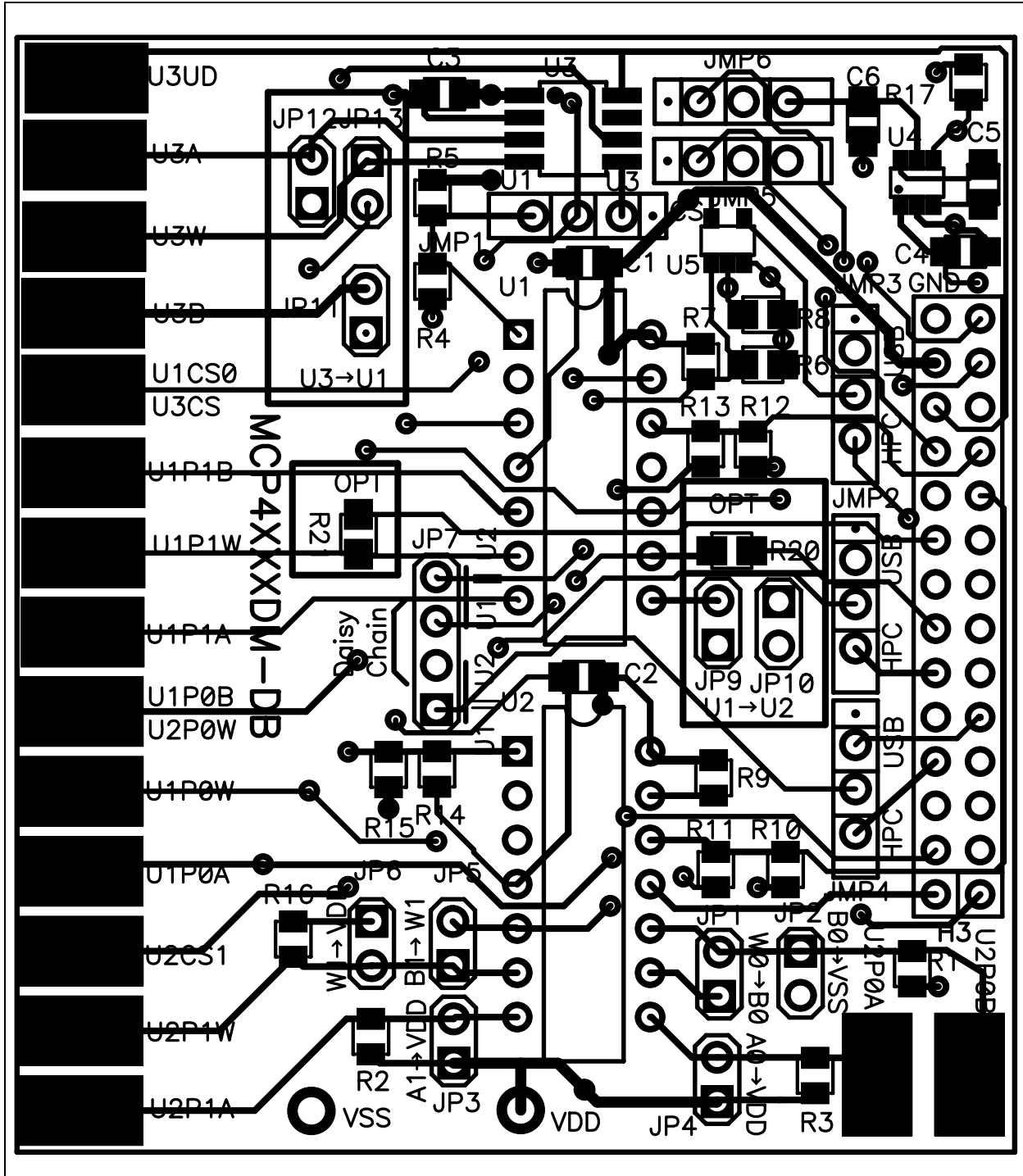

A.5 TOP LAYER

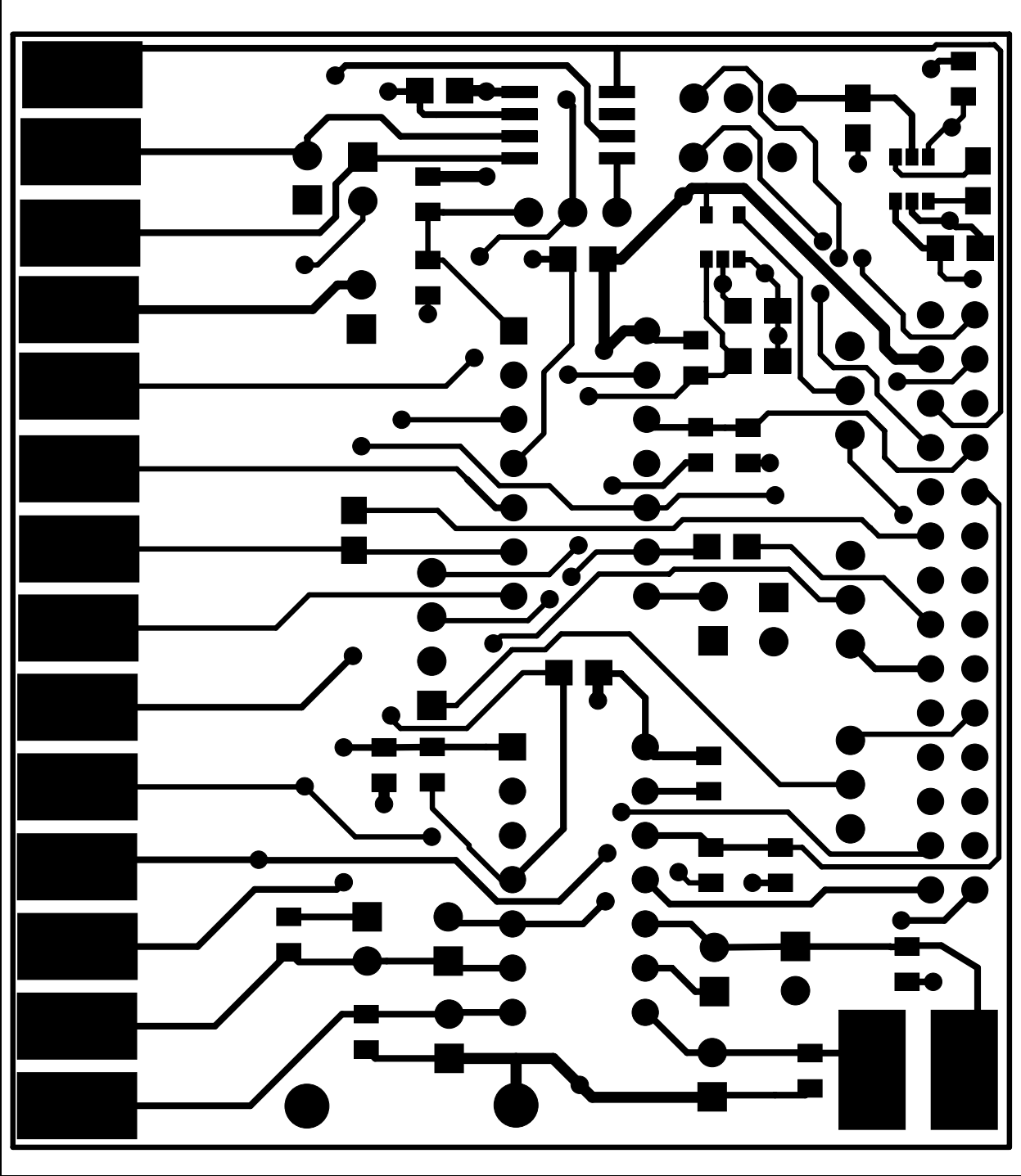

A.6 BOTTOM LAYER

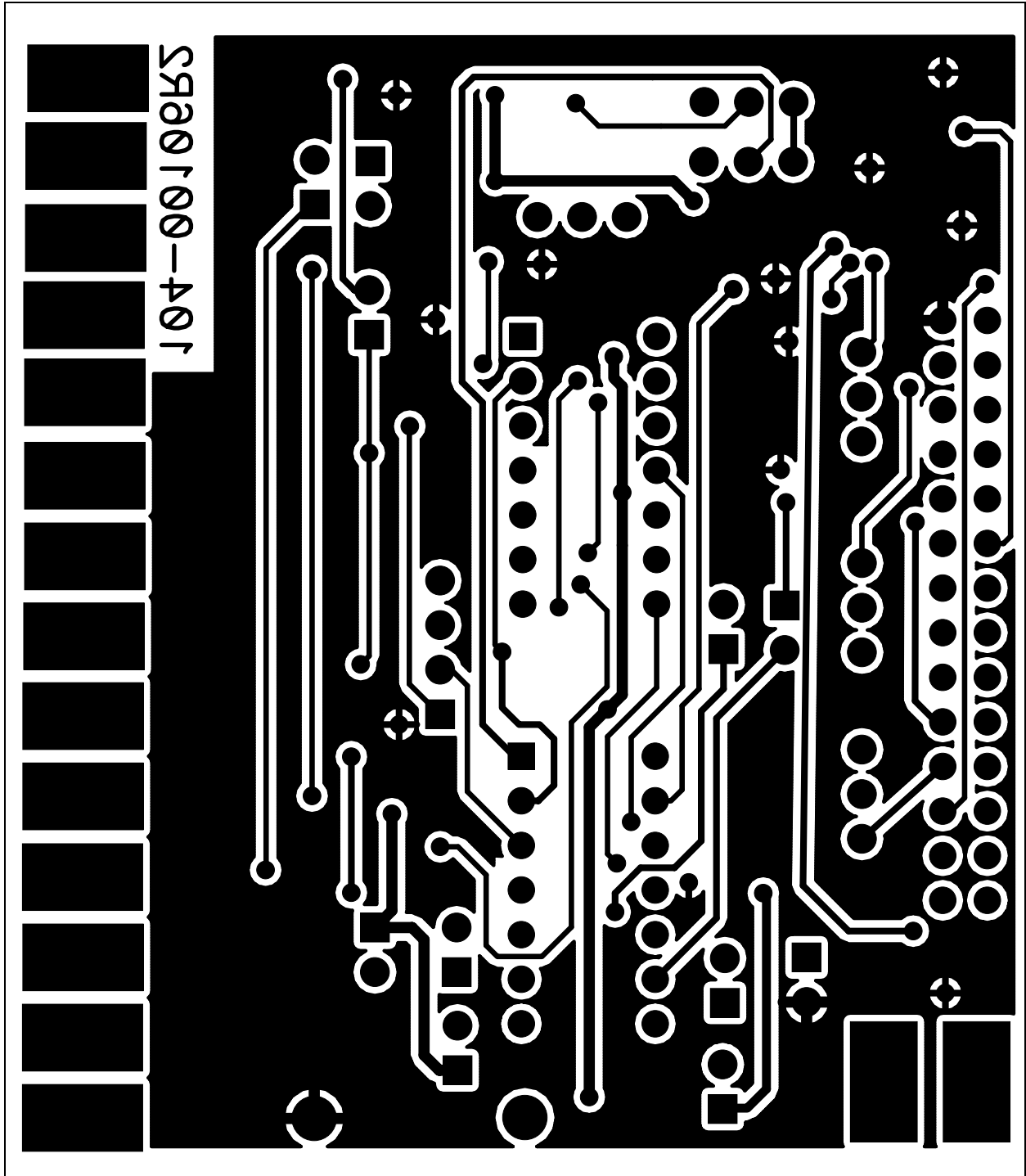

MCP4XXX Digital Potentiometer Daughter Board User's Guide

A.7 TOP COMPONENTS AND SILK SCREEN

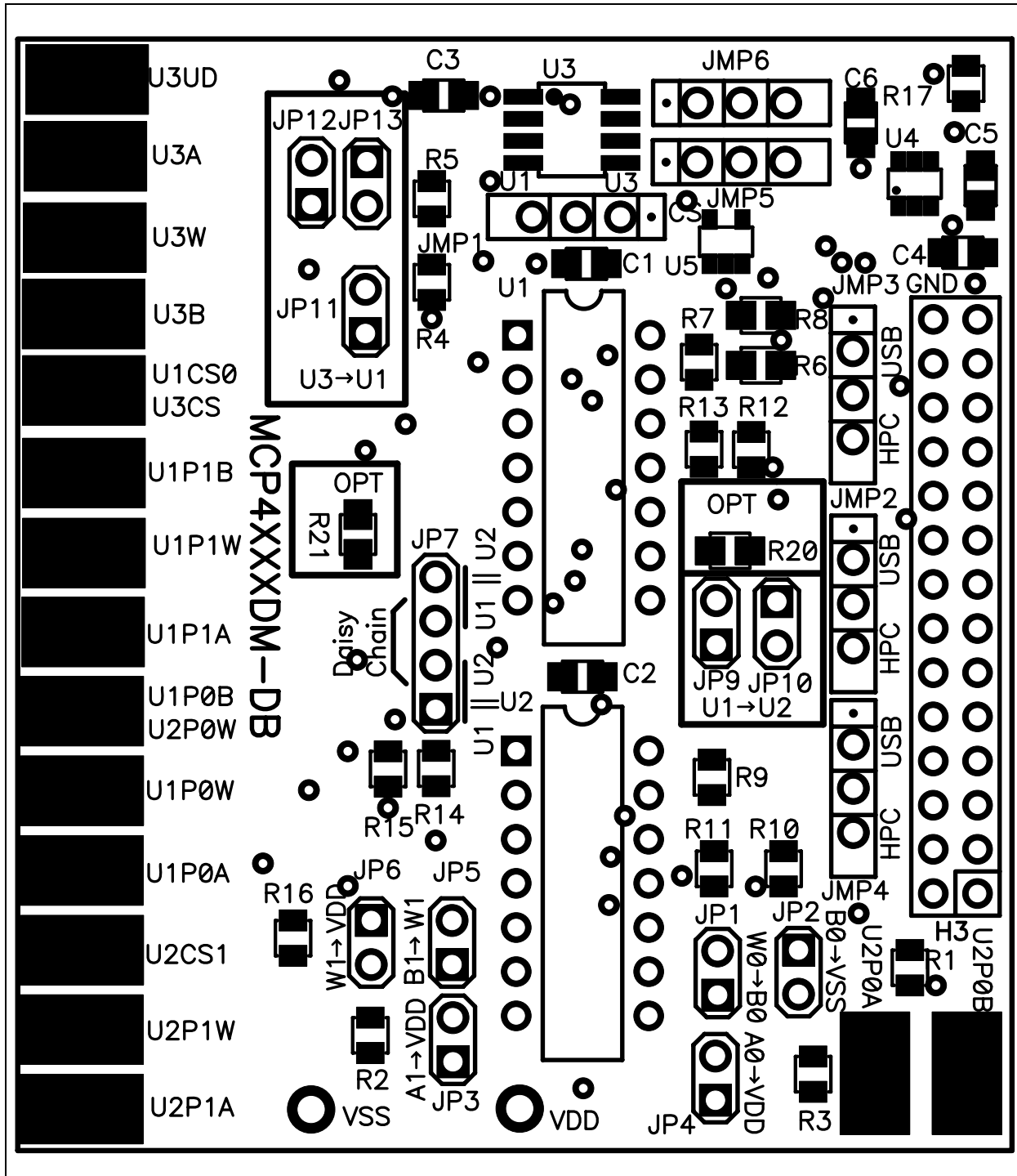



MCP4XXX DIGITAL POTENTIOMETER DAUGHTER BOARD USER'S GUIDE

Appendix B. Bill Of Materials (BOM)

TABLE B-1: BILL OF MATERIALS — INSTALLED COMPONENTS

Qty	Reference	Description	Manufacturer	Part Number
4	C1, C2, C3, C4	Device Power Supply Bypass Capacitor Surface-mount (805 package) CAP .1UF 16V CERAMIC X7R 0805	Panasonic® - ECG	ECJ-2VB1C104K
1	C5	TC1240A Charge Double capacitor Surface-mount (805 package) CAP 3.3UF 10V CERAMIC X5R 0805	Panasonic - ECG	ECJ-2FB1A335K
1	C6	TC1240A Output Filter Capacitor Surface-mount (805 package) CAP 3.3UF 10V CERAMIC X5R 0805	Panasonic - ECG	ECJ-2FB1A335K
1	H3	PICDEM Demo Board Interface Header (2x14) Male (Installed on bottom of board) .100" Straight Male Headers Double Row 28 Pin Contact	JAMECO VALUEPRO	2012-254-2X14SG-R
6	JMP1, JMP2, JMP3, JMP4, JMP5, JMP6	1x3 Header (Male) .100" Straight Male Headers 3 Contacts (Gold)	JAMECO VALUEPRO	7000-1X3SG-R
11	JP1, JP2, JP3, JP4, JP5, JP6, JP9, JP10, JP11, JP12, JP13	1x2 Header (Male) .100 MILS Singel Row Straight Male Headers 2 Contacts	JAMECO VALUEPRO	7000-1X2SG-R
1	JP7	1x4 Header (Male) HEADER,.1"ST MALE,1RW,4PIN, .025" PST,.23" GOLDTAIL	JAMECO VALUEPRO	JS-1109-4-R
1	PCB 103-00106	MCP4XXX Demo Daughter Board PCB	Microchip Technology Inc.	103-00106
2	R6, R8	OR gate input pull-down resistor (10kΩ) RES 10.0K OHM 1/8W 1% 0805 SMD	Panasonic - ECG	ERJ-6ENF1002V
1	R17	TC1240A SHDN pin pull-down resistor (100kΩ) RES 100K OHM 1/8W 1% 0805 SMD	Panasonic - ECG	ERJ-6ENF1003V
2	U1, U2	14-pin Dip Socket SOCKET,IC,14PIN,MACHINE TOOLED LOW PROFILE,SOLDERTAIL	JAMECO VALUEPRO	6100-14-R
2	U1, U2	MCP42010 (DIP footprint)	Microchip Technology Inc.	MCP42010-E/P
1	U3	MCP4021 (SOIC footprint)	Microchip Technology Inc.	MCP4021-103E/SN
1	U4	TC1240A (SOT-23-5 footprint)	Microchip Technology Inc.	TC1240AECSTR
1	U5	Single 2-Input Positive OR gate IC SGL 2IN POS-OR GATE SOT23-5	Texas Instruments	SN74AHT1G32DBVR
12	—	1x2 Shunts Shunt,SHORT BLKS W TAB BLK	JAMECO VALUEPRO	2012JH-R

Note 1: The components listed in this Bill of Materials are representative of the PCB assembly. The released BOM used in manufacturing uses all RoHS-compliant components.

MCP4XXX Digital Potentiometer Daughter Board User's Guide

TABLE B-2: BILL OF MATERIALS — COMPONENTS NOT INSTALLED

Qty	Reference	Description	Manufacturer	Part Number
0	R1, R2, R3, R4, R5, R7, R9, R10, R11, R12, R13, R14, R15, R16	Pull-up or Pull-down resistors Surface-mount (805 package)	—	—
0	R20, R21	Wiper (U1-P0W, U1-P1W) Inline resistor ⁽¹⁾ Surface-mount (805 package)	—	—

Note 1: This resistor when installed is typically 0W, but depending on the PICDEM Demo Board that it selected, modifications may be required on that PICDEM Demo Board to ensure that the wiper outputs are not adversely affected. An example of this is the removal of the R4 resistor on the PICDEM HPC Explorer Board (Rev 4 PCB) so that the circuitry on the AN1 signal line does not interfere with the operation of the U1-P0W signal.

Appendix C. Board Testing

The MCP4XXX Digital Potentiometer Daughter Board can be used in multiple configurations. Only a subset of these configurations are tested. The tests were performed with the configuration shown in Figure C-1. The tested nodes are Channel 1 through Channel 4.

Other configurations, Pad connections, and circuit performance are not tested.

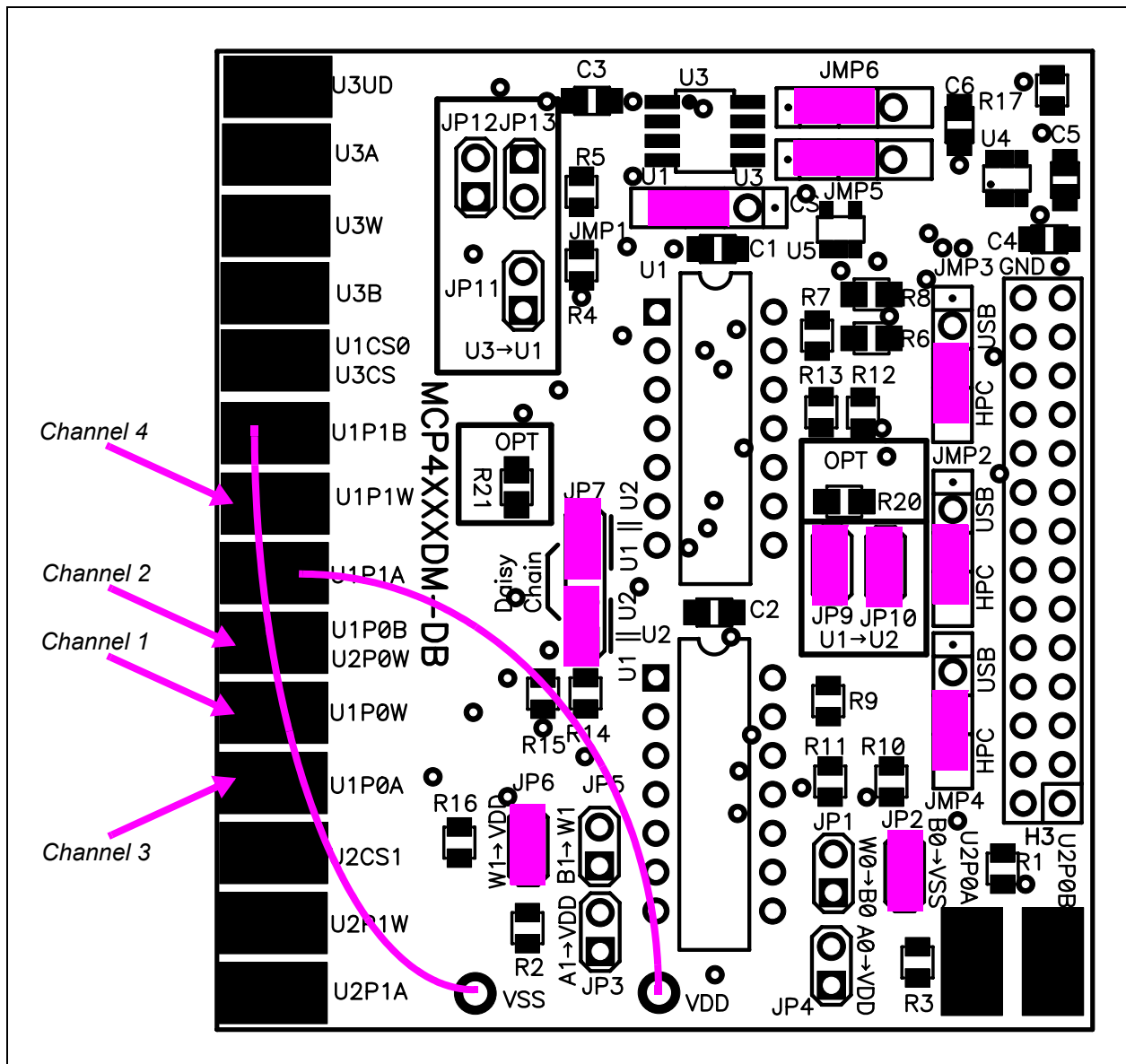

FIGURE C-1: Tested Jumper Configuration.

MCP4XXX Digital Potentiometer Daughter Board User's Guide

C.1 WHAT IS TESTED

The following portions of the board are tested:

- **MCP42010** (in U1 and U2)
 - U1 MCP42010 Pot 0 and Pot 1 are tested in Potentiometer configuration.
 - U2 MCP42010 Pot 0 and Pot 1 are tested in Rheostat configuration.
- JMP1 (P1 – P2) - $\overline{CS0}$ to U1
- JMP2 (P2 – P3) - PICDEM FS USB Demo Board Configuration
- JMP3 (P2 – P3) - PICDEM FS USB Demo Board Configuration
- JMP4 (P2 – P3) - PICDEM FS USB Demo Board Configuration
- JMP5 (P1 – P2) - $\overline{CS1}$ from H3 RE2 pin
- JMP6 (P1 – P2) - $\overline{CS0}$ from H3 RC1 pin
- JP2, JP6, JP9, and JP10
- H3 Header Signals: VDD, GND, RC5 (SDO), RC3 (SCK/SCL), RC1 (CS0), and RE2 (CS1)
- Pads: U1P1B, U1P1W, U2P1A, U1P0B (U2P0W), U1P0W, and U1P0A

C.2 WHAT IS NOT TESTED

The following portions of the board are NOT tested:

- **MCP4021** (U3)
- **TC1240A** (U4)
- SN74AHT1G32DBVR (U5)
- JP7 in Daisy Chain Configuration
- JMP1 (P1 – P2) - $\overline{CS0}$ to U3
- JMP2 (P1 – P2) - PICDEM FS USB Demo Board Configuration
- JMP3 (P1 – P2) - PICDEM FS USB Demo Board Configuration
- JMP4 (P1 – P2) - PICDEM FS USB Demo Board Configuration
- JMP5 (P2 – P3) - $\overline{CS1}$ from **TC1240A** VOUT pin
- JMP6 (P2 – P3) - $\overline{CS0}$ from **TC1240A** VOUT pin
- JP1, JP3, JP4, JP5, JP11, JP12, and JP13
- H3 Header Signals: RA5 (WP1), RA4 (WP0), RA3 (VIN), RC4 (SDI/SDA), RA0 (P0W), RA2 (P1W), RC2 (U/D), RC7 (SDO), RB5 (SHDN), RB4 (SHDN1), RB3 (SHDN0), RB1 (SCK/SCL), and RB0 (SDI/SDA)
- Pads: U3UD, U3A, U3W, U3B, U1CS0 (U3CS), U2CS1, U2P1W, U2P1A, U2P0A, and U2P0B
- Connections to unpopulated components

NOTES:



MICROCHIP

WORLDWIDE SALES AND SERVICE

AMERICAS

Corporate Office

2355 West Chandler Blvd.
Chandler, AZ 85224-6199
Tel: 480-792-7200
Fax: 480-792-7277
Technical Support:
<http://support.microchip.com>
Web Address:
www.microchip.com

Atlanta

Alpharetta, GA
Tel: 770-640-0034
Fax: 770-640-0307

Boston

Westborough, MA
Tel: 774-760-0087
Fax: 774-760-0088

Chicago

Itasca, IL
Tel: 630-285-0071
Fax: 630-285-0075

Dallas

Addison, TX
Tel: 972-818-7423
Fax: 972-818-2924

Detroit

Farmington Hills, MI
Tel: 248-538-2250
Fax: 248-538-2260

Kokomo

Kokomo, IN
Tel: 765-864-8360
Fax: 765-864-8387

Los Angeles

Mission Viejo, CA
Tel: 949-462-9523
Fax: 949-462-9608

Santa Clara

Santa Clara, CA
Tel: 408-961-6444
Fax: 408-961-6445

Toronto

Mississauga, Ontario,
Canada
Tel: 905-673-0699
Fax: 905-673-6509

ASIA/PACIFIC

Asia Pacific Office

Suites 3707-14, 37th Floor
Tower 6, The Gateway
Harbour City, Kowloon
Hong Kong
Tel: 852-2401-1200
Fax: 852-2401-3431

Australia - Sydney

Tel: 61-2-9868-6733
Fax: 61-2-9868-6755

China - Beijing

Tel: 86-10-8528-2100
Fax: 86-10-8528-2104

China - Chengdu

Tel: 86-28-8676-6200
Fax: 86-28-8676-6599

China - Fuzhou

Tel: 86-591-8750-3506
Fax: 86-591-8750-3521

China - Hong Kong SAR

Tel: 852-2401-1200
Fax: 852-2401-3431

China - Qingdao

Tel: 86-532-8502-7355
Fax: 86-532-8502-7205

China - Shanghai

Tel: 86-21-5407-5533
Fax: 86-21-5407-5066

China - Shenyang

Tel: 86-24-2334-2829
Fax: 86-24-2334-2393

China - Shenzhen

Tel: 86-755-8203-2660
Fax: 86-755-8203-1760

China - Shunde

Tel: 86-757-2839-5507
Fax: 86-757-2839-5571

China - Wuhan

Tel: 86-27-5980-5300
Fax: 86-27-5980-5118

China - Xian

Tel: 86-29-8833-7250
Fax: 86-29-8833-7256

ASIA/PACIFIC

India - Bangalore

Tel: 91-80-4182-8400
Fax: 91-80-4182-8422

India - New Delhi

Tel: 91-11-4160-8631
Fax: 91-11-4160-8632

India - Pune

Tel: 91-20-2566-1512
Fax: 91-20-2566-1513

Japan - Yokohama

Tel: 81-45-471-6166
Fax: 81-45-471-6122

Korea - Gumi

Tel: 82-54-473-4301
Fax: 82-54-473-4302

Korea - Seoul

Tel: 82-2-554-7200
Fax: 82-2-558-5932 or
82-2-558-5934

Malaysia - Penang

Tel: 60-4-646-8870
Fax: 60-4-646-5086

Philippines - Manila

Tel: 63-2-634-9065
Fax: 63-2-634-9069

Singapore

Tel: 65-6334-8870
Fax: 65-6334-8850

Taiwan - Hsin Chu

Tel: 886-3-572-9526
Fax: 886-3-572-6459

Taiwan - Kaohsiung

Tel: 886-7-536-4818
Fax: 886-7-536-4803

Taiwan - Taipei

Tel: 886-2-2500-6610
Fax: 886-2-2508-0102

Thailand - Bangkok

Tel: 66-2-694-1351
Fax: 66-2-694-1350

EUROPE

Austria - Wels

Tel: 43-7242-2244-3910
Fax: 43-7242-2244-393

Denmark - Copenhagen

Tel: 45-4450-2828
Fax: 45-4485-2829

France - Paris

Tel: 33-1-69-53-63-20
Fax: 33-1-69-30-90-79

Germany - Munich

Tel: 49-89-627-144-0
Fax: 49-89-627-144-44

Italy - Milan

Tel: 39-0331-742611
Fax: 39-0331-466781

Netherlands - Drunen

Tel: 31-416-690399
Fax: 31-416-690340

Spain - Madrid

Tel: 34-91-708-08-90
Fax: 34-91-708-08-91

UK - Wokingham

Tel: 44-118-921-5869
Fax: 44-118-921-5820

07/21/06

Mouser Electronics

Authorized Distributor

Click to View Pricing, Inventory, Delivery & Lifecycle Information:

[Microchip:](#)

[MCP4XXXDM-DB](#)