

VI-200 / VI-J00 Family

Design Guide & Applications Manual

*DC-DC Converters and
Configurable Power Supplies*



Table of Contents

VI-/MI-200 and VI-/MI-J00 DC-DC Converters

1. Zero-Current Switching	2
2. DC-DC Converter Pinouts	3
3. Module Dos and Don'ts	4
4. Overcurrent Protection	7
5. Output Voltage Trimming	8
6. Multiple GATE IN Connections	11
7. Application Circuits / Converter Array Design Considerations	12
8. Using Boosters and Parallel Arrays	14
9. EMC Considerations	18
10. Optional Output Filters	29

Filter & Front-End Modules

11. Battery Charger (BatMod™)	30
12. AC Input Module (AIM™ / MI-AIM™)	33
13. Harmonic Attenuator Module (HAM™)	37
14. Input Attenuator Module (IAM™ / MI-IAM™)	43
15. Ripple Attenuator Module (RAM™ / MI-RAM™)	47
16. Offline Front End	48
17. DC Input Power System (ComPAC™ / MI-ComPAC™ Family)	52
18. AC Input Power System (FlatPAC™ Family)	55
19. AC Input Power System (PFC FlatPAC™)	58

General

20. Thermal and Module Mounting Considerations	60
21. Thermal Curves	68
22. Lead-Free Pins (RoHS)	78
23. Tin-Lead Pins	83
24. Module Packaging Options (SlimMod™, FinMod™, BusMod and MegaMod™ Families)	88
25. Product Weights	89
26. Glossary of Technical Terms	90

NOTE: This Design Guide and Applications Manual does **not** address Vicor Maxi, Mini and Micro DC-DC converters. For more information on these products go to vicorpower.com.

Overview

Vicor offers RoHS compliant modules. These modules have a “VE” prefix. The information presented herein applies to both versions, and “VI” will be the default designation.

The heart of the Vicor VI-/MI-200 and VI-/MI-J00 module technology, zero-current-switching, allows Vicor converters to operate at frequencies in excess of 1MHz, with high efficiency and power density. Depending on input voltage and load, the converters operate at frequencies ranging from the low hundreds of kilohertz (light load, high line) to approximately one megahertz (full load, low line). Another aspect of the Vicor topology is that two or more power trains driven at the same frequency will inherently load-share if their outputs are tied together. Load sharing is dynamic and is within 5%. The VI-200 and MI-200 product line offer both Driver and Booster modules:

- Drivers and Boosters must have identical power trains.
- Drivers close the voltage loop internally, Boosters do not.
- Boosters may be slaved to a Driver, allowing configurations of multi-kilowatt arrays, which exhibit dynamic current sharing between modules.
- Only a single control connection is needed between modules with all module’s power inputs and outputs, connected together — no trimming, adjustments, or external components are required to achieve load sharing.

Lossless Energy Transfer

Referring to Figure and Table 1.1 below, turn-on of the MOSFET switch transfers a quantized energy packet from the input source to an LC “tank” circuit, composed of inherent transformer leakage inductance of T1 and a capacitive element, C, in the secondary. Simultaneously, an approximately half-sinusoidal current flows through the switch, resulting in switch turn-on at zero current and turn-off when current returns to zero. Resonance, or bidirectional energy flow, cannot occur because D1 will only permit unidirectional energy transfer. A low-pass filter (Lo, Co) following the capacitor produces a low ripple DC output. The result is a virtually lossless energy transfer from input to output with greatly reduced levels of conducted and radiated noise.

I_p :	Primary current
V_p :	Primary voltage
V_s :	Secondary voltage
OVP:	Overvoltage protection (output)
OTS:	Overtemperature shutdown
OC1, OC2:	Opto-coupler
E/A:	Error amplifie
REF:	Bandgap reference
C/L:	Current limit amplifier

Table 1.1

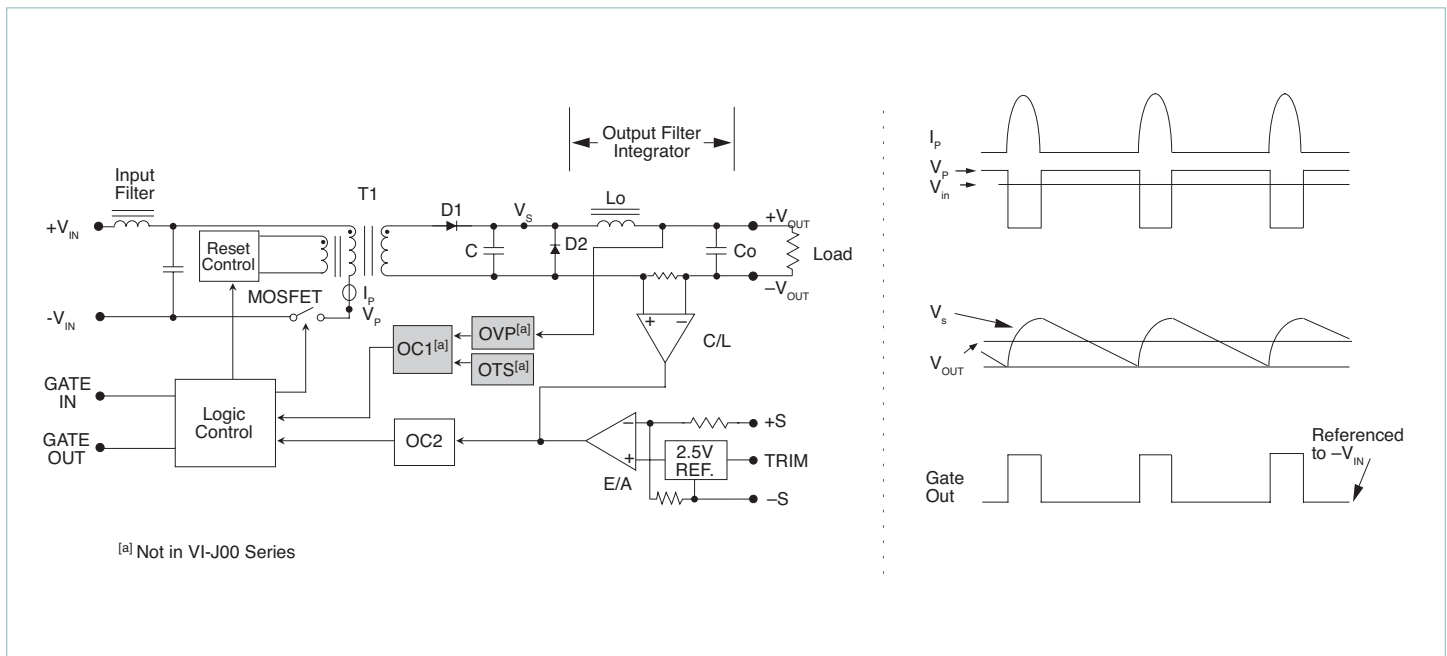
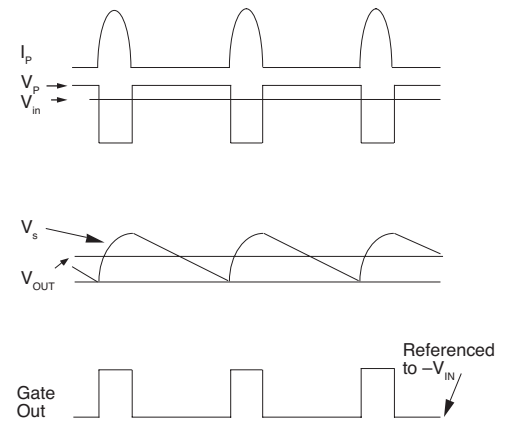

Figure 1.1 — VI-IMI-200 and VI-IMI-J00 series zero-current-switching block diagram



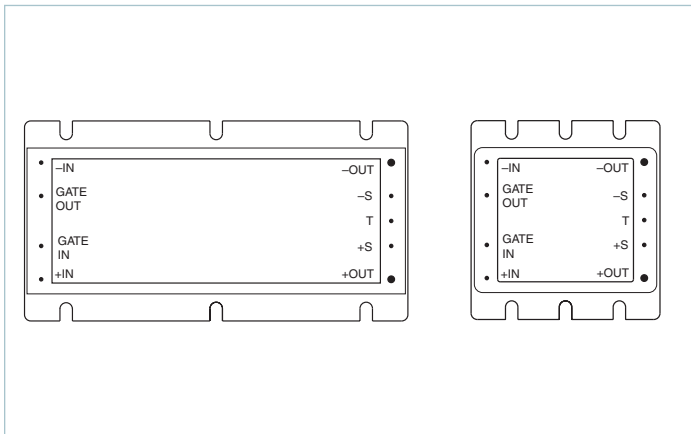

Figure 2.1 — VI-MI-200, VI-MI-J00

-IN, +IN: DC voltage inputs. See Tables 2.1 and 2.2 for nominal input voltages and ranges for the VI-/MI-200 and VI-/MI-J00 Family converter modules (data sheets contain Low Line, 75% Max. Power and Transient ratings).

VI-200, VI-J00 Input Voltage Ranges			
Designator	Low	Nominal	High
0	10V	12V	20V
V	10V	12/24V	36V
1	21V	24V	32V
W	18V	24V	36V
2	21V	36V	56V
3	42V	48V	60V
N	36V	48V	76V
4	55V	72V	100V
T	66V	110V	160V
5	100V	150V	200V
6	200V	300V	400V
7	100V	150/300V	375V

Table 2.1 — VI-200, VI-J00 input voltage ranges

MI-200, MI-J00 Input Voltage Ranges			
Designator	Low	Nominal	High
2	18V	28V	50V
5	100V	155V	210V
6	125V	270V	400V
7	100V	165V	310V

Table 2.2 — MI-200, MI-J00 input voltage ranges

GATE OUT: The pulsed signal at the GATE OUT pin of a regulating Driver module is used to synchronously drive the GATE IN pin of a companion Booster module to effect power sharing between the Driver and the Booster. Daisy-chaining additional Boosters (connecting GATE OUT of one unit to GATE IN of a succeeding unit) leads to a virtually unlimited power expansion capability.

GATE IN: The GATE IN pin on a Driver module may be used as a logic Enable / Disable input. When GATE IN is pulled low (<0.65V at 6mA, referenced to -VIN), the module is turned off; when GATE IN is floating (open collector), the module is turned on. The open circuit voltage of the GATE IN pin is less than 10V.

-OUT, +OUT: DC output pins. See the Table 2.3 and 2.4 below for output voltages and power levels of VI-/MI-200 and VI-/MI-J00 Family converter modules.

VI-200, VI-J00 Standard Output Voltages			
Designator	Output	Designator	Output
Z	2V	2	15V
Y	3.3V	N	18.5V
O	5V	3	24V
X	5.2	L	28V
W	5.5V	J	36V
V	5.8V	K	40V
T	6.5V	4	48V
R	7.5V	H	52V
M	10V	F	72V
1	12V	D	85V
P	13.8V	B	95V

Table 2.3 — VI-200, VI-J00 output voltage designators

Output Voltage	Power Level		Power Level	
	VI-200	VI-J00	High	MI-J00
<5V _{DC}	10 – 40A	5 – 20A	10 – 30A	5 – 10A
≥5V _{DC}	50 – 200W	25 – 100W	50 – 100W	10 – 50W

Table 2.4 — Output voltage vs. power level

Special output voltages from 1 – 95V; consult factory.

T (TRIM): Provides fixed or variable adjustment of the module output.

Trimming Down: Allows output voltage of the module to be trimmed down, with a decrease in efficiency. Ripple as a percent of output voltage goes up and input range widens since input voltage dropout (loss of regulation) moves down.

Trimming Up: Reverses the above effects.

-S, +S (-SENSE, +SENSE): Provides for locating the point of optimal voltage regulation external to the converter. Output OVP in VI-/MI-200 will trip if remote sense compensates output voltage measured at output pins above 110% of nominal. Discrete wire used for sense must be tightly twisted pair. Do not exceed 0.25V drop in negative return; if the voltage drop exceeds 0.25V in the negative return path, the current limit set point will increase. Connect +SENSE to +OUT and -SENSE to -OUT at the module if remote sensing is not desired (Figure 7.4).

Electrical Considerations GATE IN and GATE OUT Pins

Logic Disable: When power is applied to the input pins, the GATE IN pin of a Driver can be pulled low with respect to the –IN thus turning off the output while power is still applied to the input. (Figure 7.1)

Caution: With offline applications –IN is not earth ground.

In Logic Disable mode, the GATE IN pin should be driven from either an “open collector” or electromechanical switch that can sink 6mA when on (GATE IN voltage less than 0.65V). If driven from an electromechanical switch or relay, a 1µF capacitor should be connected from GATE IN to –IN to eliminate the effects of switch “bounce”. The 1µF capacitor may be required in all applications to provide a “soft start” if the unit is disabled and enabled quickly. Do not exceed a repetitive on / off rate of 1Hz to the GATE IN or input voltage pins.

High Power Arrays: The pulsed signal at the GATE OUT pin of a regulating Driver module is used to synchronously drive the GATE IN pin of a companion Booster module to effect power sharing between the Driver and the Booster. (Figure 7.5) Daisy-chaining additional Boosters (i.e., connecting GATE OUT to GATE IN of a succeeding unit) leads to a virtually unlimited power expansion capability. VI-/MI-200 series modules of the same family and power level can be paralleled (i.e., Driver, VI-260-CU with Booster, VI-B60-CU).

In general:

- Don't drive the GATE IN pin from an “analog” voltage source.
- Don't leave GATE IN pins of Booster modules unterminated.
- Don't overload GATE OUT; limit load to a single Vicor module GATE IN connection, or 1kΩ, minimum, in parallel with 100pF, maximum.
- Don't skimp on traces that interconnect module –IN pins in high power arrays. GATE IN and GATE OUT are referenced to –IN; heavy, properly laid out traces will minimize parasitic impedances that could interfere with proper operation.
- Do use a decoupling capacitor across each module's input (see Input Source Impedance that follows).
- Do use an EMI suppression capacitor from +/– input and output pins to the baseplate.
- Do use a fuse on each module's + input to prevent fire in the event of module failure. See safety agency conditions of acceptability for the latest information on fusing. Please see the Vicor website for Safety Approvals.

Input Source Impedance: The converter should be connected to an input source that exhibits low AC impedance. A small electrolytic capacitor should be mounted close to the module's input pins. (C3, Figure 3.1) This will restore low AC impedance, while avoiding the potential resonance associated with “high-Q” film capacitors. The minimum value of the capacitor, in microfarads, should be $C(\mu\text{F}) = 400 \div V_{\text{IN}}$ minimum. Example: V_{IN} , minimum, for a VI-260-CV is 200V. The minimum capacitance would be $400 \div 200 = 2\mu\text{F}$. For applications involving long input lines or high inductance, additional capacitance will be required.

The impedance of the source feeding the input of the module directly affects both the stability and transient response of the module. In general, the source impedance should be lower than the input impedance of the module by a factor of ten, from DC to 50kHz.

To calculate the required source impedance, use the following formula:

$$Z = 0.1(V_{\text{LL}})^2 / P_{\text{IN}}$$

Where: **Z** is required input impedance
V_{LL} is the low line input voltage
P_{IN} is the input power of the module

Filters, which precede the module, should be well damped to prevent ringing when the input voltage is applied or the load on the output of the module is abruptly changed.

Input Transients: Don't exceed the transient input voltage rating of the converter. Input Attenuator Modules or surge suppressors in combination with appropriate filtering, should be used in offline applications or in applications where source transients may be induced by load changes, blown fuses, etc. For applications where the input voltage may go below low line it is recommended that an undervoltage lockout circuit be used to pull GATE IN low to disable the converter module. The undervoltage lockout circuit should induce a delay of at least one second before restarting the converter module. Longer delays will be required if external capacitance is added at the output to insure the internal soft start is re-initialized.

NOTE: Do not allow the rate of change of the input voltage to exceed 10V/µs for any input voltage deviation.

The level of transient suppression required will depend on the severity of the transients. A Zener diode, TRANSZORB™ or MOV will provide suppression of transients under 100µs and act as a voltage clipper for DC input transients. It may be necessary to incorporate an LC filter for larger energy transients. This LC filter will integrate the transient energy while the Zener clips the peak voltages. The Q of this filter should be kept low to avoid potential resonance problems. See Section 14, Input Attenuator Module (IAM / MI-IAM) for additional information on transient suppression.

Output OVP: The VI-/MI-200, with the exception of VI-/MI-J00s, has an internal overvoltage protection circuit that monitors the voltage across the output power pins. It is designed to latch the converter off at 115 – 135% of rated output voltage. It is not a crowbar circuit, and if a module is trimmed above 110% of rated output voltage, OVP may be activated. Do not backdrive the output of the converter module to test the OVP circuit.

Caution: When trimming up VI-/MI-J00 modules, additional care should be taken as an improper component selection could result in module failure. Improper connection of the sense leads on VI-/MI-J00 modules can also result in an excessive overvoltage condition and module failure.

Input Reverse Voltage Protection: The module may be protected against reverse input voltages by the addition of a diode in series with the positive input, or a reverse shunt diode with a fuse in series with the positive input. See [Section 14](#), the Input Attenuator Module (IAM / MI-IAM) provides input reverse voltage protection when used with a current limiting device (fuse).

Thermal / Mechanical Considerations

Baseplate. Operating temperature of the baseplate, as measured at the center mounting slot on the –IN, –OUT side, can not exceed rated maximum. ThermMate or thermal compound should be used when mounting the module baseplate to a chassis or heat sink. All six mounting holes should be used. Number six (#6) machine screws should be torqued to 5 – 7in-lbs, and use of Belleville washers is recommended.

The module pins are intended for PCB mounting either by wave soldering to a PCB or by insertion into one of the recommended PCB socket solutions.

CAUTION: Use of discrete wires soldered directly to the pins may cause intermittent or permanent damage to the module; therefore, it is not recommended as a reliable interconnection scheme for production as a final released product. See [Section 21](#) for packaging options designed for discrete wire connections (BusMod, MegaMod).

In addition, modules that have been soldered into printed circuit boards and have subsequently been removed should not be reused.

Thermal and Voltage Hazards

Vicor component power products are intended to be used within protective enclosures. Vicor DC-DC converters work effectively at baseplate temperatures, which could be harmful if contacted directly. Voltages and high currents (energy hazard) present at the pins and circuitry connected to them may pose a safety hazard if contacted or if stray current paths develop. Systems with removable circuit cards or covers which may expose the converter(s) or circuitry connected to the converters, should have proper guarding to avoid hazardous conditions.

EMC Considerations

All applications utilizing DC-DC converters must be properly bypassed, even if no EMC standards need to be met. Bypass IN and OUT pins to each module baseplate as shown in Figure 3.1. Lead length should be as short as possible. Recommended values vary depending on the front end, if any, that is used with the modules, and are indicated on the appropriate data sheet. In most applications, C1a – C1b is a 4,700pF Y-capacitor (Vicor Part # 01000) carrying the appropriate safety agency approval; C2a – C2b is a 4,700pF Y-capacitor (Vicor Part # 01000) or a 0.01µF ceramic capacitor rated at 500V. In PCB mount applications, each of these components is typically small enough to fit under the module baseplate flange.

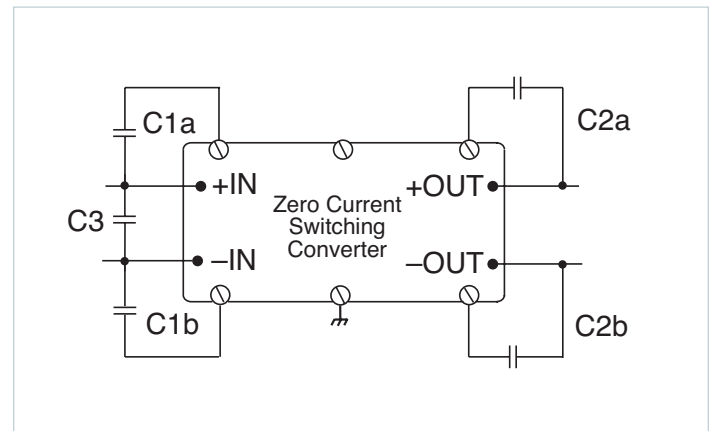

Figure 3.1 — IN and OUT pins bypassed to the module baseplate and input cap for low AC impedance

Safety Considerations

Shock Hazard: Agency compliance requires that the baseplate be grounded.

Fusing: Internal fusing is not provided in Vicor DC-DC converters. To meet safety agency conditions, a fuse is required. This fuse should be placed in the positive input lead, not the negative input lead, as opening of the negative input lead will cause the GATE IN and GATE OUT to rise to the potential of the +IN lead, causing possible damage to other modules or circuits that share common GATE IN or GATE OUT connections.

Safety agency conditions of acceptability require module input fusing. The VI-x7x, VI-x6x and VI-x5x require the use of a Buss PC-Tron fuse or other DC-rated fuse. See below for suggested fuse ratings.

The safety approvals section of the Vicor website should always be checked for the latest fusing and conditions of acceptability information for all DC-DC converters including the MegaMod family.

Acceptable Fuse Types and Current Rating for the VI-200 and VI-J00 Family of Converters

Package Size	Required Fuse	Package Size	Required Fuse
VI-27x-xx	PC-Tron 2.5A	VI-J7x-xx	PC-Tron 2.5A
VI-26x-xx	PC-Tron 3A	VI-J6x-xx	PC-Tron 3A
VI-25x-xx	PC-Tron 5A	VI-J5x-xx	PC-Tron 5A
VI-2Tx-xx	PC-Tron 5A	VI-JTx-xx	PC-Tron 5A
VI-24x-xx	6A / 125V	VI-J4x-xx	PC-Tron 5A
VI-2Nx-xx	8A / 125V	VI-JNx-xx	PC-Tron 5A
VI-23x-xx	8A / 125V	VI-J3x-xx	PC-Tron 5A
VI-22x-xx	8A / 60V	VI-J2x-xx	PC-Tron 5A
VI-2Wx-xx	12A / 50V	VI-JWx-xx	8A / 60V
VI-21x-xx	12A / 32V	VI-J1x-xx	8A / 60V
VI-2Vx-xx	12A / 32V	VI-J0x-xx	8A / 60V
VI-20x-xx	12A / 32V		

Foldback Current Limiting

The VI-/MI-200 modules with output voltages of 5V or 3.3V incorporate foldback current limiting. (Figure 4.1) In this mode, the output voltage remains constant up to the current knee, (I_C), which is 5 – 25% greater than full-rated current, (I_{MAX}). Beyond I_C , the output voltage falls along the vertical line I_C-I_{FB} until approximately 2V. At $\leq 2V$, the voltage and current folds back to short circuit current (20 – 80% of I_{MAX}). Typically, modules will automatically recover when overcurrent is removed.

When bench testing modules with foldback current limiting, use a constant resistance load as opposed to a constant current load. Some constant current loads have the ability to pull full current at near zero volts. This may cause a latchup condition. Also when performing a short circuit test it is recommended to use a mercury wetted relay to induce the output short as other methods may induce switch bounce that could potentially damage the converter.

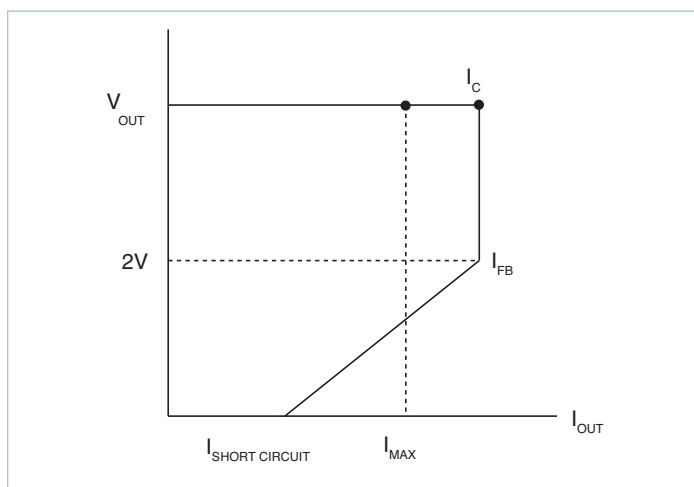

Figure 4.1 — Foldback current limiting

Straight Line Current Limiting

The VI-/MI-200 modules with output voltages greater than 5V, 2V (VI-/MI-200 only) and all VI-/MI-J00 modules incorporate a straight-line type current limit. (Figure 4.2) As output current is increased beyond I_{MAX} , the output voltage remains constant and within its specified limits up to a point, I_C , which is 5 – 25% greater than rated current, (I_{MAX}). Beyond I_C , the output voltage falls along the vertical line to I_{SC} . Typically, modules will automatically recover after overcurrent is removed.

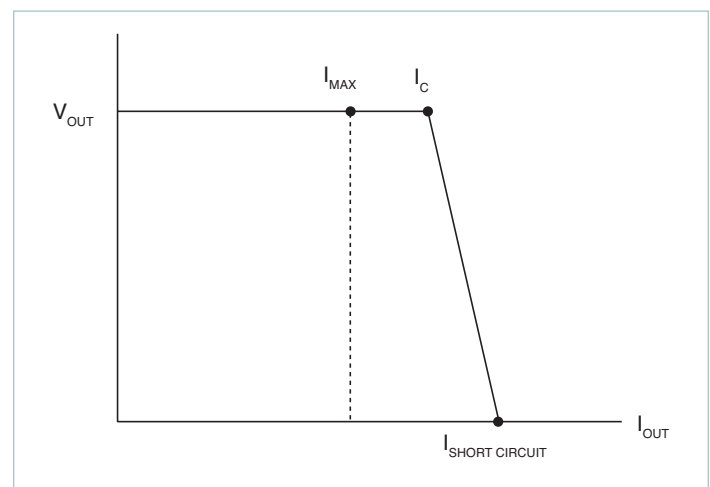

Figure 4.2 — Straight-line current limiting

Overview

Specifications such as efficiency, ripple and input voltage range are a function of output voltage settings. As the output voltage is trimmed down, efficiency goes down; ripple as a percent of V_{OUT} goes up and the input voltage range widens since input voltage dropout (loss of regulation) moves down. As the units are trimmed up, the reverse of the above effects occurs.

All converters have a fixed current limit. The overvoltage protection setpoint is also fixed; trimming the output voltage does not alter its setting. As the output voltage is trimmed down, the current limit setpoint remains constant. Therefore, in terms of output power, if the unit is trimmed down, available output power drops accordingly.

The output voltage of most Vicor converters can be trimmed +10%, -50%. Certain modules have restricted trim ranges. Consult the latest datasheet for details.

Do not attempt to trim the module output voltage more than +10%, as overvoltage shut down may occur. Do not exceed maximum rated output power when the module is trimmed up.

Caution: When trimming up VI-/MI-J00 converter modules, additional care should be taken as an improper component selection could result in module failure. Improper connection of the sense leads on VI-/MI-J00 converter modules can also result in an excessive overvoltage condition and module failure.

The following procedures describe methods for output voltage adjustment (-10 to +10% of nominal) of the VI-/MI-200, VI-/MI-J00, ComPAC/MI-ComPAC, FlatPAC and MegaMod/MI-MegaMod families.

Modules with nominal 3.3V outputs and above have the 2.5V precision reference and 10kΩ internal resistor. For trim resistor calculations on modules with 2.0V outputs use 0.97V in place of the 2.5V reference and substitute 3.88kΩ for the internal 10kΩ resistor.

Resistors are 0.25W. When trimming down any module, always maintain a minimum preload of at least 1% of rated output power and in some cases up to 10% may be required. For more specific information on trimming down a specific module, please consult the Vicor Applications Engineering Department at (800) 927-9474.

Resistive Adjustment Procedure

To achieve a variable trim range, an external resistor network must be added. (Figure 5.1)

Example 1: For trimming -10% to +10% with a standard off-the-shelf 10kΩ potentiometer (R7), values for resistors R6 and R8 need to be calculated.

Resistor R6 limits the trim down range. For a given percentage, its value is independent of output voltage. Refer to [Table 5.1](#), for limiting resistor values.

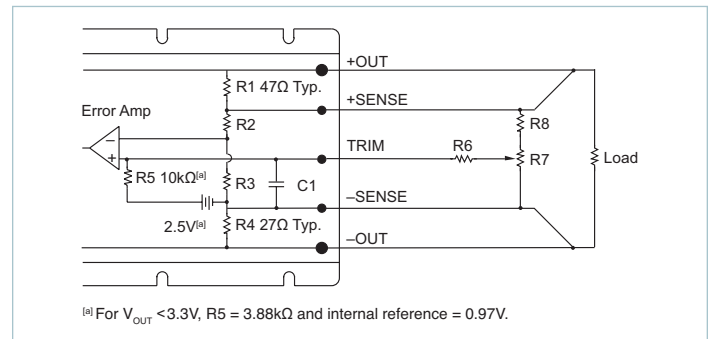

Figure 5.1 — External resistive network for variable trimming

Trimming Down -10%

A 10% drop of the 2.5V reference at the trim pin is needed to effect a 10% drop in the output voltage. (Figure 5.2)

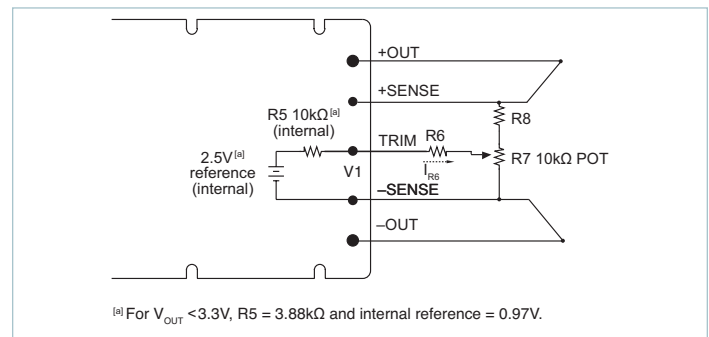

Figure 5.2 — Circuit diagram "Trim Down"

$$V_1 = 2.5V - 10\% = 2.25V$$

Therefore:

$$I_{R5} = \frac{(2.5V - 2.25V)}{10k\Omega} = 25\mu a$$

Since $I_{R5} = I_{R6} = 25\mu A$:

$$R6 = \frac{2.25V}{25\mu a} = 90k\Omega$$

This value will limit the trim down range to -10% of nominal output voltage.

Trimming Up +10%

To trim 10% above the nominal output voltage, the following calculations are needed to determine the value of R8. This calculation is dependent on the output voltage of the module. A 12V output will be used as an example. (Figure 5.3)

It is necessary for the voltage at the trim pin to be 10% greater than the 2.5V reference. This offset will cause the error amplifier to adjust the output voltage up 10% to 13.2V.

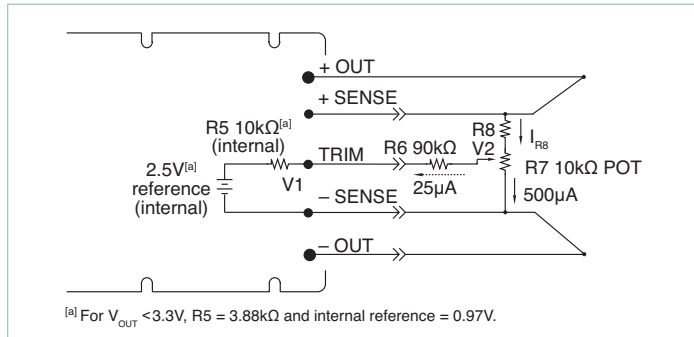

Figure 5.3 — Circuit diagram “Trim Up”

$$V_i = 2.5V + 10\% = 2.75V$$

$$I_{R5} = \frac{(2.5V - 2.25V)}{10k\Omega} = 25\mu A$$

Since $I_{R5} = I_{R6}$, the voltage drop across R6 = (90kΩ) (25μA) = 2.25V.

Therefore, $V_2 = 2.75V + 2.25V = 5V$. The current through R7 (10kΩ pot) is:

$$I_{R7} = \frac{V_2}{R7} = \frac{5}{10k\Omega} = 500\mu A$$

Using Kirchoff’s current law:

$$I_{R8} = I_{R7} + I_{R6} = 525\mu A$$

Thus, knowing the current and voltage, R8 can be determined:

$$V_{R8} = (V_{OUT} + 10\%) - V_2 = 13.2V - 5V = 8.2V$$

$$R8 = \frac{(8.2V)}{525\mu A} = 15.6k\Omega$$

This resistor configuration allows a 12V output module to be trimmed up to 13.2V and down to 10.8V. Follow this procedure to determine resistor values for other output voltages.

Fixed Trim

Converters can be trimmed up or down with the addition of one external resistor, either R_U for programming up or R_D for programming down. (Figure 5.4)

Example 2: Fixed Trim Up (12V to 12.6V).

To determine R_U , the following calculation must be made:

$$2.5V + 5\% = 2.625V$$

$$V_{R5} = V_{TRIM} - V_{REF}$$

$$V_{R5} = 2.625 - 2.5 = 0.125V$$

Knowing this voltage, the current through R5 can be found:

$$I_{R5} = \frac{V_{R5}}{R5} = \frac{0.125}{10k\Omega} = 12.5\mu A$$

$$V_{Ru} = 12.6V - 2.625V = 9.975V$$

$$Ru = \frac{9.975}{12.5\mu A} = 798k\Omega$$

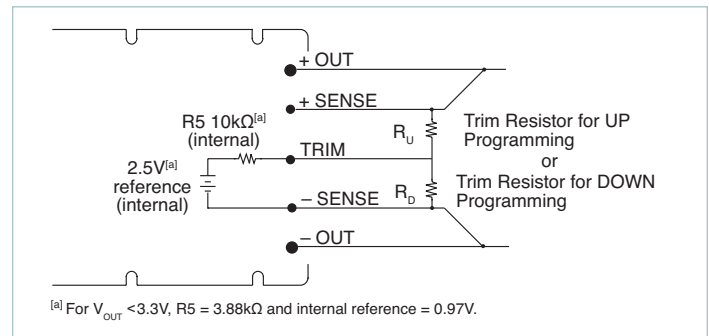

Figure 5.4 — Fixed trimming

Connect R_U from the trim pin to the +SENSE. Be sure to connect the resistor to the +SENSE, not the +OUT, or drops in the positive output lead as a function of load will cause apparent load regulation problems.

Example 3: –25% Fixed Trim Down (24V to 18V).

The trim down methodology is identical to that used in Example 2, except that it is utilized to trim the output of a 24V module down 25% to 18V. The voltage on the trim pin must be reduced 25% from its nominal setting of 2.5V. This is accomplished by adding a resistor from the trim pin to –SENSE.

$$2.5V - 25\% = 1.875V$$

$$V_{R5} = V_{BANDGAP} - V_{TRIM}$$

$$= 2.5V - 1.875V = 0.625V$$

Knowing this voltage, the current through R5 can be found:

$$I_{R5} = \frac{V_{R5}}{R5} = \frac{0.625}{10k\Omega} = 62.5\mu\text{A}$$

The voltage across the resistor, R_D, and the current flowing through it are known:

$$R_D = \frac{(2.5V - 0.625V)}{62.5\mu\text{A}} = 30k\Omega$$

Connect R_D (Figure 5.4) from the TRIM pin to the –SENSE of the module. Be sure to connect the resistor to the SENSE, not the –OUT, or drops in the negative output lead as a function of load will cause apparent load regulation problems.

Values for Trim Down by Percentage	
Percent	Resistance
-5%	190kΩ
-10%	90kΩ
-15%	56.7kΩ
-20%	40kΩ
-25%	30kΩ
-30%	23.3kΩ
-35%	18.6kΩ
-40%	15kΩ
-45%	12.2kΩ
-50%	10kΩ

Table 5.1 — Values for trim down by percentage (Refer to product data sheet for allowable trim ranges at vicorpower.com)

Fixed Trim Down		
V _{NOM}	V (Desired)	Trim Resistor ^[a]
5V	4.5V	90.9kΩ
	3.3V	19.6kΩ
	2.5V	10.0kΩ
15V	13.8V	115kΩ
	20V	49.9kΩ
48V	40V	49.9kΩ
	36V	30.1kΩ

Table 5.2a — Values for fixed trim down by voltage

Fixed Trim Up		
V _{NOM}	V (Desired)	Trim Resistor ^[a]
5V	5.2V	261kΩ
	5.5V	110kΩ
12V	12.5V	953kΩ
	13.2V	422kΩ
15V	15.5V	1.62MΩ
	16.5V	562kΩ
24V	25V	2.24MΩ
48V	50V	4.74MΩ

Table 5.2b — Values for fixed trim up by voltage

^[a] Values listed in the tables are the closest standard 1% resistor values.

Dynamic Adjustment Procedure

Output voltage can also be dynamically programmed by driving the TRIM pin from a voltage or current source; programmable power supplies and power amplifier applications can be addressed in this way. For dynamic programming, drive the TRIM pin from a source referenced to the negative sense lead, and keep the drive voltage in the range of 1.25 – 2.75V. Applying 1.25 – 2.5V on the TRIM pin corresponds to 50 – 100% of nominal output voltage. For example, an application requires a +10, 0% (nominal), and a –15% output voltage adjustment for a 48V output converter. Referring to the table below, the voltage that should be applied to the trim pin would be as follows:

V _{TRIM}	V _{OUT}	Change from Nominal
2.125	40.8	-15%
2.5	48	0
2.75	52.8	+10%

The actual voltage range is further restricted by the allowable trim range of the converter. Voltages in excess of 2.75V (+10% over nominal) may cause overvoltage protection to be activated. For applications where the module will be programmed on a continuous basis the slew rate should be limited to 30Hz sinusoidal.

Trimming on the Web (vicorpower.com)

Trim values are calculated automatically. Design Calculators are available on Vicor's website in the PowerBench™ section at: www.vicorpower.com/powerbench.

Resistor values can be easily determined for fixed trim up, fixed trim down and for variable trimming applications.

In addition to trimming information, the website also includes design tips, applications circuits, EMC suggestions, thermal design guidelines and PDF data sheets for all available Vicor products.

The screenshot shows a web-based calculator titled "Resistor Values for Fixed Output Voltage Trimming". It includes a "back to main window" button. The "Vicor product" section has radio buttons for "VI-200" (selected), "VI-J00", and "Maxi, Mini, and Micro". A note states: "Notes: VI-200 and VI-J00 — Minimum preload of 1% should be maintained. Maxi, Mini, and Micro — Consult factory when trimming below -10%". The "Nominal output voltage" is set to 5V. The "Trim range" is set to 2.5 to 5.5 V or Vnom -50 to +10%. The "Desired output voltage" is set to 5.5 V or Vnom +10%. A "Clear Output Voltage" button is below. The "calculate" button is active, and the "Trim resistor value" is displayed as 110 K ohm. A "Reset" button is also present. At the bottom, a circuit diagram shows the connection of the trim resistor (Ru) and sense resistor (Rd) between the TRIM pin and the -Sense pin.

Overview

A number of GATE IN pins may be connected for remote shut down and logic disable. (Figure 6.1) Diodes D1 and D2 provide isolation and prevent multiple failures if the GATE IN of a module becomes shorted to the +IN. The Zener diodes Z1, Z2 and capacitors C1, C2 attenuate transient voltage spikes caused by differential inductance in the negative lead. Capacitors C1 and

C2 will also lengthen turn-on time. SW1 is a mechanical or solid state switch that is used to disable both Driver modules. C3 is used to minimize the effects of "switch bounce" associated with mechanical devices.

NOTE: GATE IN voltage needs to be <0.65 V referenced to -IN to ensure modules are disabled.

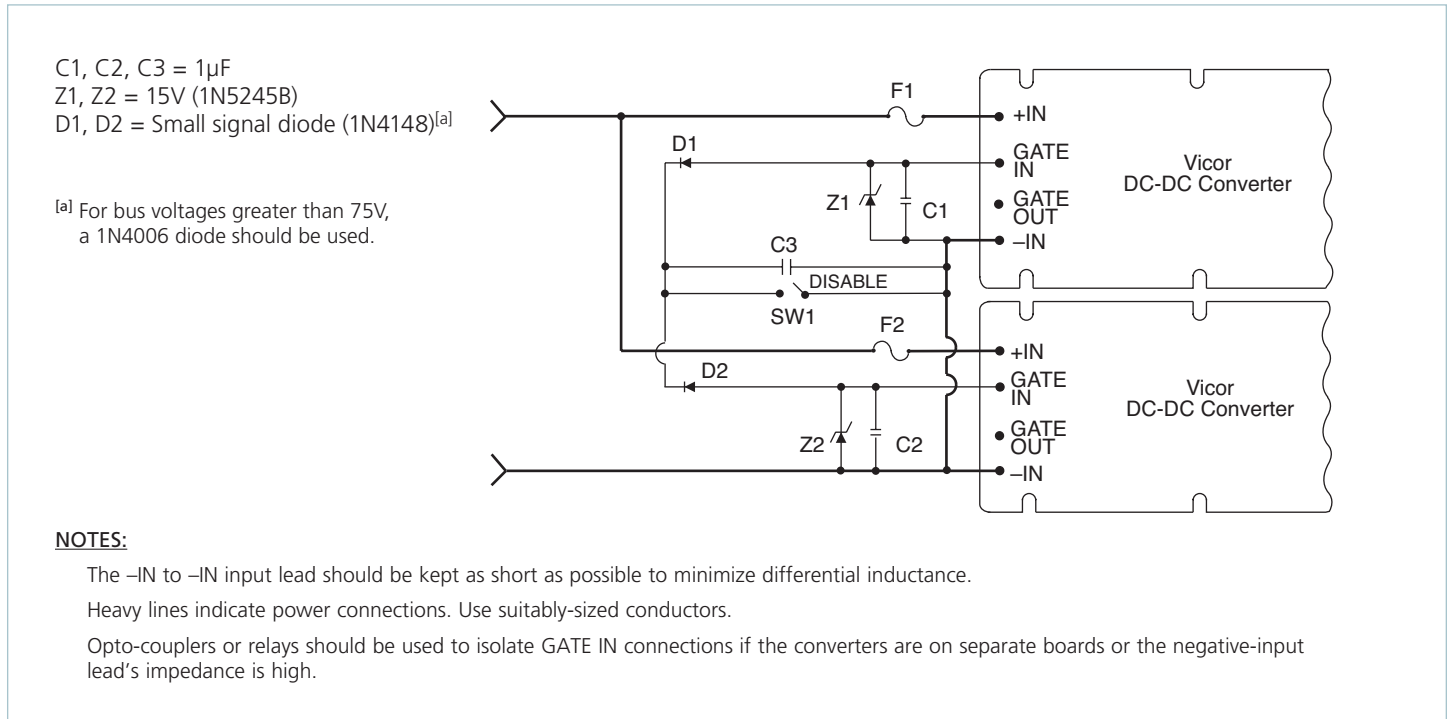

Figure 6.1 — Protection for multiple GATE IN connections

Logic Disable: (Figure 7.1) The GATE IN pin of the module may be used to turn the module on or off. When GATE IN is pulled low (<0.65V at 6mA, referenced to -V_{IN}), the module is turned off. When GATE IN is floating (open collector), the module is turned on. The open circuit voltage of the GATE IN pin is less than 10V. This applies to VI-/MI-200, VI-/MI-J00 and MegaMod / MI-MegaMod Family modules.

Output Voltage Programming: (Figure 7.2) Consult the Vicor Applications Engineering Department before attempting large signal applications at high repetition rates due to ripple current considerations with the internal output capacitors. This applies to VI-/MI-200, VI-/MI-J00, ComPAC / MI-ComPAC, FlatPAC and MegaMod / MI-MegaMod Family modules.

$$V_{OUT} = \frac{V_{TRIM} \cdot V_{NOM}}{2.5}$$

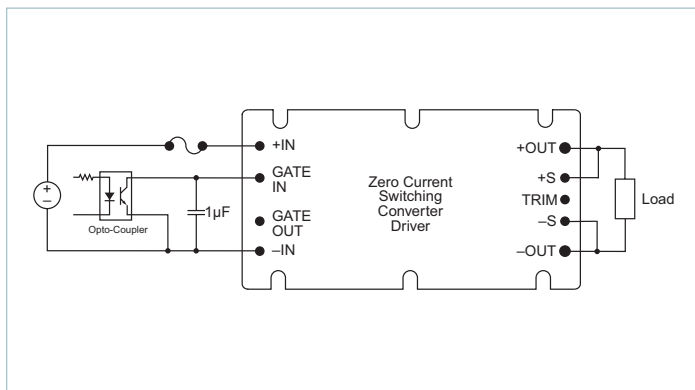

Figure 7.1 — Logic disable

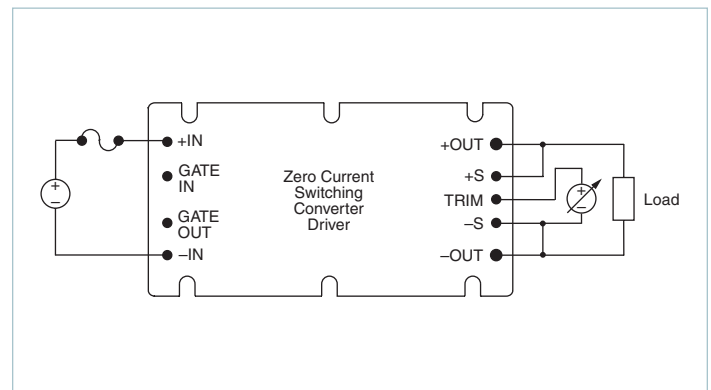

Figure 7.2 — Output voltage programming

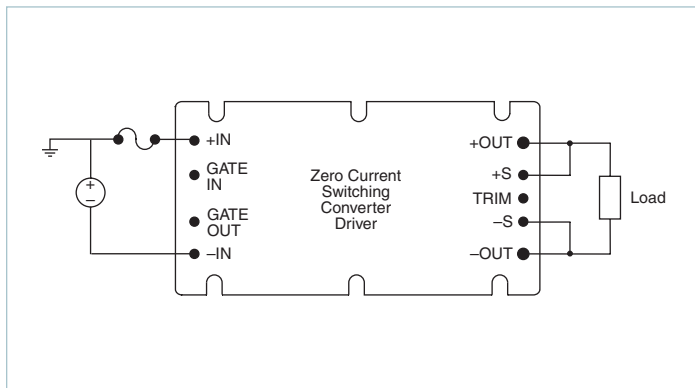

Figure 7.3 — Negative inputs (with positive ground)

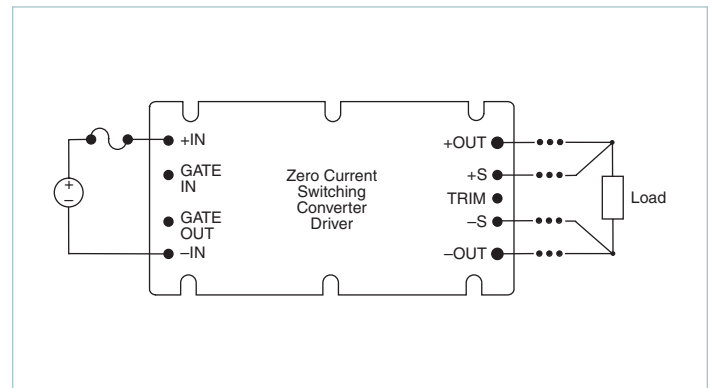

Figure 7.4 — Remote sensing

Negative Inputs (with positive ground): (Figure 7.3) Vicor modules have isolated inputs and outputs making negative input configurations easy. Fusing should always be placed in the positive lead.

Remote Sensing: (Figure 7.4) Output voltage between +OUT and -OUT must be maintained below 110% of nominal. Do not exceed 0.25V drop in negative return as the current limit setpoint is moved out proportionately. The sense should be closed at the module if remote sensing is not desired. Applies to VI-/MI-200, VI-/MI-J00, ComPAC / MI-ComPAC, FlatPAC and MegaMod / MI-MegaMod Family modules. Excessively long sense leads and / or excessive external capacitance at the load may result in module instability. Please consult Vicor Applications Engineering for compensation methods.

Parallel Boost: (Figure 7.5) U.S. Patent #4,648,020 – other patents pending. To retain accurate power sharing between a Driver and (n) number of Boosters, provide adequate input and output power bussing. This applies to VI-/MI-200 and MegaMod / MI-MegaMod Family modules. See [Module Dos and Don'ts](#) for recommended external components. (Section 3)

Programmable Current Source: (Figure 7.6) Module output voltage should not exceed the rated voltage of the operational amplifier. This applies to VI-/MI-200, VI-/MI-J00, ComPAC / MI-ComPAC, FlatPAC and MegaMod / MI-MegaMod Family modules.

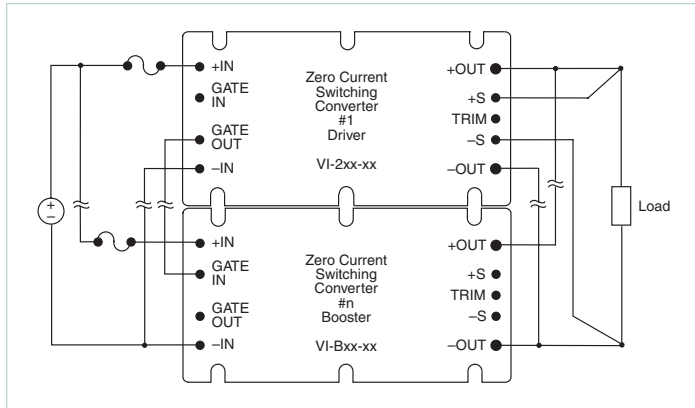

Figure 7.5 — Parallel boost. U.S. Patent #4,648,020; other patents pending

NOTE: When using a VI-J00 module, the TRIM pin voltage should be clamped to 2.75V to avoid damage to the module. This corresponds to the maximum trim up voltage. This circuit or functional equivalent must be used when charging batteries. Do not exceed the nominal current ratings of the converter. Example:

$$\frac{P_{OUT}}{V_{NOMINAL}}$$

Dual Output Voltages: (Figure 7.7) Vicor modules have isolated outputs so they can easily be referenced to a common node creating positive and / or negative rails.

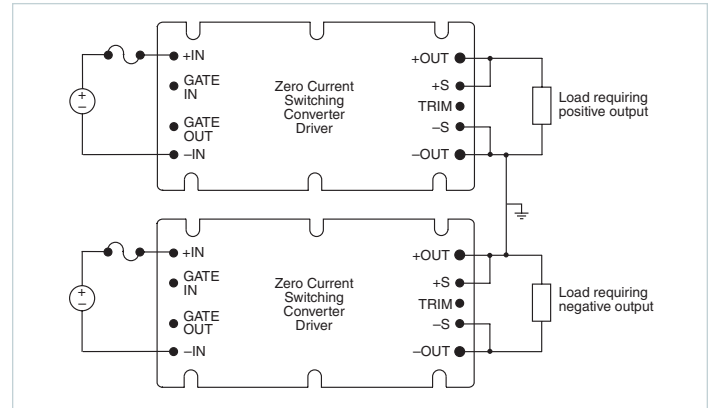

Figure 7.7 — Dual output voltages

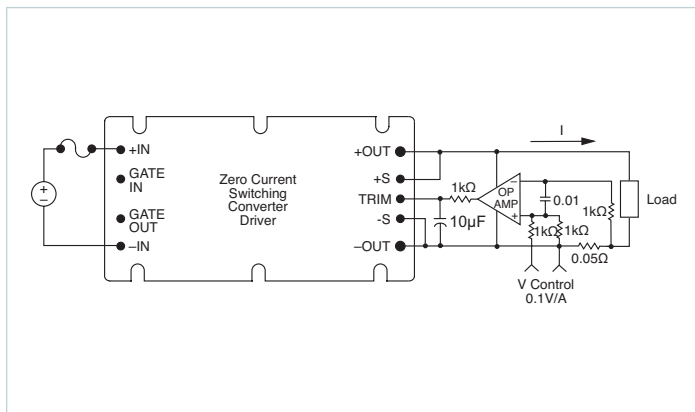

Figure 7.6 — Programmable current source

Overview

The VI-/MI-200 Family of DC-DC converters are available as Driver or Booster modules. The Driver can be used as a stand-alone module or in multi-kilowatt arrays by adding parallel Boosters. Booster modules do not contain feedback or control circuitry, so it is necessary to connect the Booster GATE IN pin to the preceding Driver or Booster GATE OUT, to synchronize operation. Drivers and Boosters have identical powertrains, although Drivers close the voltage loop internally while Boosters do not.

The concept behind Driver / Booster operation is that two or more ZCS powertrains driven at the same frequency will inherently load share if their inputs and outputs are tied together. Slaved modules require only one connection between units when their outputs are connected together; no trimming, adjustments or external components are required to achieve load sharing. The load sharing is dynamic and typically within 5%.

For additional information, refer to Electrical Considerations – High Power Arrays in [Module Dos and Don'ts](#). (Section 3)

IMPORTANT: It is important to remember that when using Boosters, the input voltage, output voltage and output power of the Boosters must be the same as the Driver.

Whenever power supplies or converters are operated in a parallel configuration – for higher output power, fault tolerance or both – current sharing is an important consideration. Most current-sharing schemes employed with power converters involve analog approaches. One analog method artificially increases the output impedance of the converter modules, while another actually senses

the output current of each module and forces all of the currents to be equal by feedback control.

Synchronous current sharing offers an alternative to analog techniques. In a synchronous scheme, there is no need for a current-sensing or current-measuring device on each module. Nor is there a need to artificially increase output impedance, which compromises load regulation.

There are advantages and disadvantages associated with each approach to current sharing. In choosing the best approach for a given application, designers should be aware of the tradeoffs as well as tips for implementing a successful design.

Most paralleled power components, such as transistors, rectifiers, power conversion modules and offline power supplies, will not inherently share the load. With power converters, one or more of the converters will try to assume a disproportionate or excessive fraction of the load unless forced current-sharing control is designed into the system.

One converter, typically the one with the highest output voltage, may deliver current up to its current limit setting, which is beyond its rated maximum. Then, the voltage will drop to the point where another converter in the array – the one with the next highest voltage – will begin to deliver current. All of the converters in an array may deliver some current, but the load will be shared unequally. With built-in current limiting, one or more of the converters will deliver current up to the current limit (generally 15 or 20% above the module's rated maximum), while other converters in the array supply just a fraction of load.

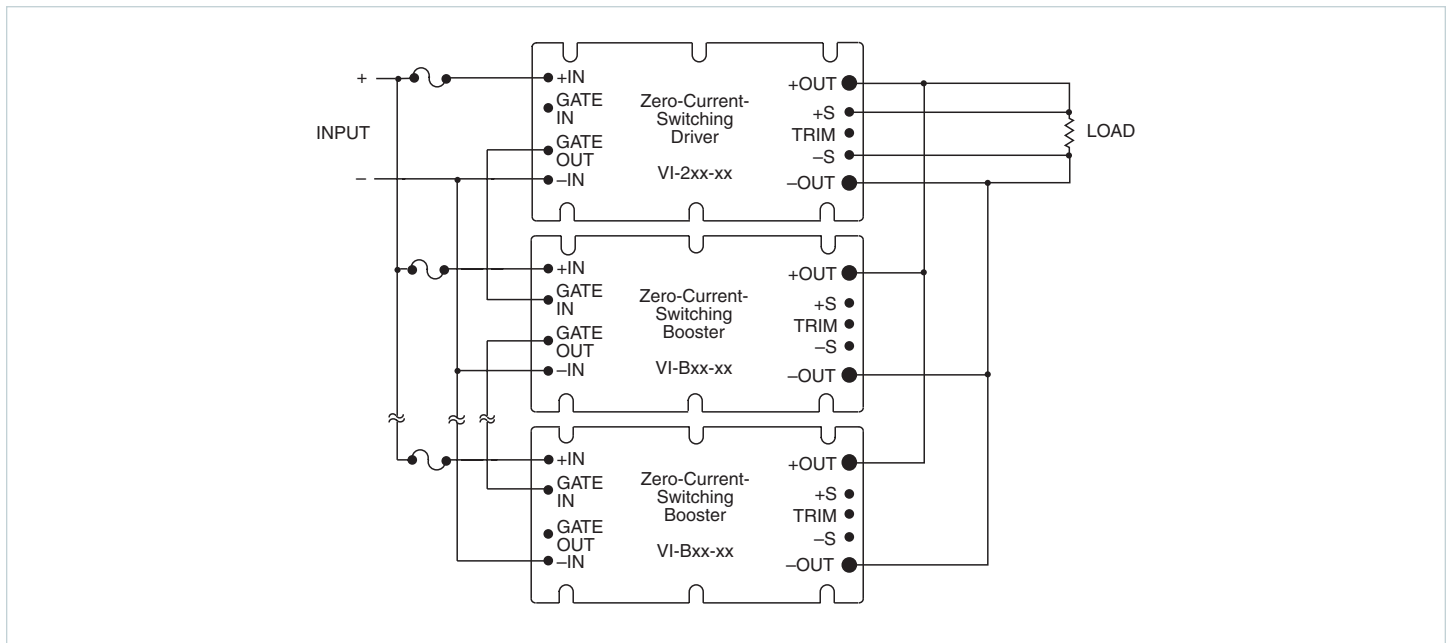

Figure 8.1 — Parallel array

Consider a situation where one module in a two-module array is providing all of the load. If it fails, the load on the second module must go from no load to full load. During that time, the output voltage is likely to droop temporarily. This could result in system problems, including shut down or reset.

On the other hand, if both modules were sharing the load and one failed, the surviving module would experience a much less severe transient (one-half to full load). Also, the output voltage would be likely to experience no more than a slight momentary droop. The dynamic response characteristic of all forward converters, resonant or pulse-width modulated, is degraded when the load is stepped from zero (no load) where the output-inductor current is discontinuous.

In the same two-module array example, the module carrying all of the load also is generating all of the heat. That results in a much lower mean time between failure for that module. An often-quoted rule of thumb says that for each 10°C increase in operating temperature, average component life is cut in half.

In a current-sharing system, the converters or supplies all run at the same temperature. This temperature is lower than that of the hot-running (heavily-loaded) modules in a system without current sharing. Furthermore, same-temperature operation means that all of the modules in a current-sharing arrangement age equally.

Current sharing, then, is important because it improves system performance. It optimizes transient and dynamic response and minimizes thermal problems, which improves reliability and helps extend the lifetimes of all of the modules in an array. Current sharing is an essential ingredient in most systems that use multiple power supplies or converters to achieve higher-output power or fault tolerance.

When parallel supplies or converters are used to increase power, current sharing is achieved through a number of approaches. One scheme simply adds resistance in series with the load. A more practical variant of that is the “droop-share” method, which actively causes the output voltage to drop in response to increasing load. Nevertheless, the two most commonly used approaches to paralleling converters for power expansion are Driver / Booster arrays and analog current-sharing control. They appear to be similar, but the implementation of each is quite different.

Driver / Booster arrays usually contain one intelligent module or Driver and one or more powertrain-only modules or Boosters. Analog current-sharing control involves paralleling two or more identical modules, each containing intelligence.

One of the common methods of forcing load sharing in an array of parallel converters is to sense the output current of each converter and compare it to the average current. Then, the output of a given converter is adjusted so that its contribution is equal to the average. This is usually accomplished by current-sense resistors in series with the load, a sensing amplifier for each converter module, and a summing amplifier. Load sharing is accomplished by actively trimming the output voltage using trim or sense pins.

Occasionally, a designer is tempted to avoid the expense of a current-sense resistor by using the IR drops in the wire as a means of sensing the current. Unfortunately, there are a number of negative issues associated with that idea. First of all, there's the temperature coefficient of copper. As the wire heats up, its

resistance increases, negating its value as a stable current-sensing device. Second, there are oxidation and corrosion issues, which also cause parametric changes. Consequently, a high-precision current-sensing device, such as a precision resistor, is a must.

The resistor values typically range from a few mΩ up to about 100mΩ, depending on the power level or current range of operation. Selecting the right value requires a tradeoff between power dissipation and sensitivity (signal-to-noise ratio or noise immunity). The larger the resistor value, the better the noise immunity – and the greater the power dissipation.

Determining the size of the resistor needed to generate a signal above the noise can be a bit tricky. Another potential pitfall with this (or, for that matter, any other) approach is the need for good electrical and mechanical design and layout. This requires adequate trace widths, minimized trace lengths and decoupling to reduce noise. An experienced designer should have no difficulty with this, but it is an area rich with opportunities for error.

The droop-share method artificially increases the output impedance to force the currents to be equal. It's accomplished by injecting an error signal into the control loop of the converter, causing the output voltage to vary as a function of load current. As load current increases, output voltage decreases. All of the modules will deliver approximately the same current because they are all being summed into one node.

If one supply is delivering more current than another supply, its output voltage will be slightly forced down so that it will be delivering equal current for an equal voltage at the summing node. A simple implementation of the droop-share scheme uses the voltage dropped across an ORing diode, which is proportional to current, to adjust the output voltage of the associated converter. (Figure 8.2)

Droop share has advantages and disadvantages. One of the advantages is that it can work with any topology. It's also fairly simple and inexpensive to implement. Though, a major drawback is that it requires that the current be sensed. A current-sensing device is needed in each of the converters or power supplies. Additionally, a small penalty is paid in load regulation, though in many applications this isn't an issue.

In general, mixing and matching converters isn't recommended – especially those with incompatible current-sharing schemes. The droop-share method, however, is more forgiving in this regard than any of the other techniques. With a little external circuitry, current sharing can be achieved using arrays constructed from different converter models or even from different suppliers.

Most systems can employ the Driver / Booster (or master / slave) array for increased power. (Figure 8.3) The Driver is used to set and control output voltage, while Booster modules, as slaves to the master, are used to extend output power to meet system requirements.

Driver / Booster arrays of quasi-resonant converters with identical powertrains inherently current share because the per-pulse energy of each converter is the same. If the inputs and outputs are tied together and the units operate at the same frequency, all modules will deliver equal current (within component tolerances).

The single intelligent module in the array determines the transient response, which does not change as modules are added. Slaved

modules require only one connection between units when their outputs are connected. No trimming, adjustments or external components are required to achieve load sharing. The load sharing is dynamic and usually guaranteed within 5%. It's important to remember that when using Boosters, the input and output voltage and output power specifications of the Boosters must be the same as the Driver.

Driver / Booster arrays have two advantages. They have only a single control loop, so there are no loop-within-a-loop stability issues. And, they have excellent transient response. However, this arrangement isn't fault tolerant. If the Driver module fails, the array won't maintain its output voltage.

Analog current-sharing control involves paralleling two or more identical modules, each containing intelligence. The circuit actively adjusts the output voltage of each supply so the multiple supplies deliver equal currents. This method, though, has a number of disadvantages. Each converter in the array has its own voltage regulation loop and each requires a current-sensing device and current-control loop.

Analog current-sharing control does support a level of redundancy. But it's susceptible to single-point failures within the current-sharing bus that at best can defeat current sharing and at worst can destroy every module in the array. The major reason for this is the single-wire galvanic connection between modules.

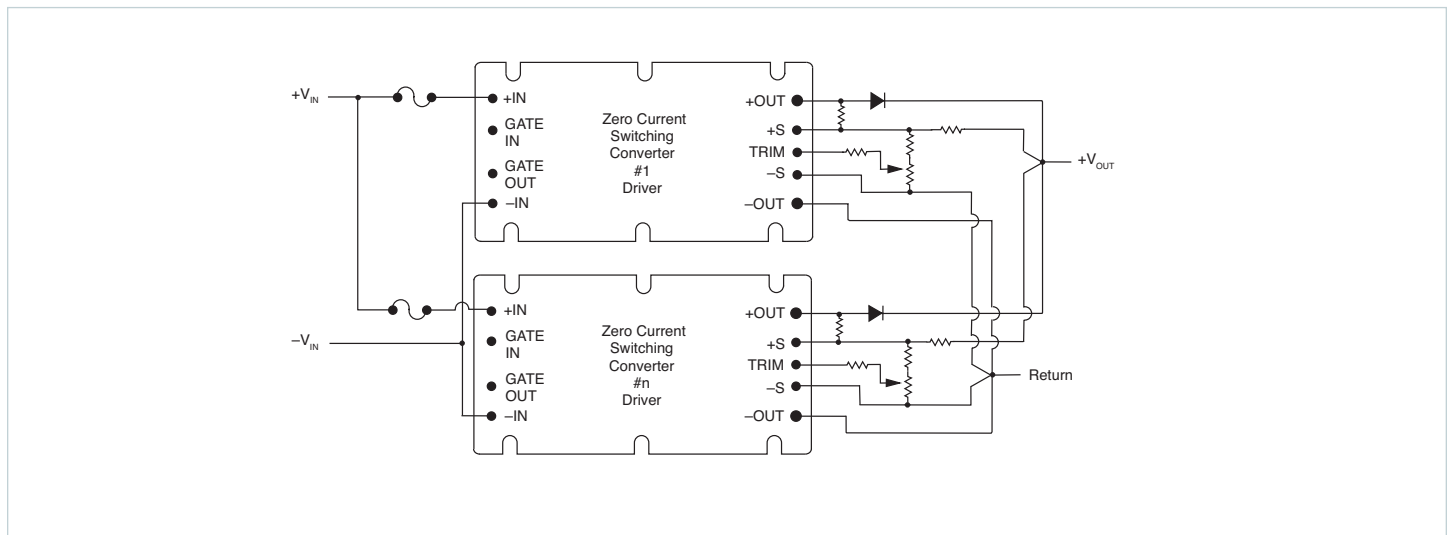

Figure 8.2 — Droop-share current sharing artificially increases converter output impedance to force the currents to be equal; diodes on the output of each converter provide current sensing and fault protection

Current sharing is an essential element in fault-tolerant arrays. Yet regardless of the approach, there is an inherent cost incurred by the addition of at least one redundant converter or supply.

Incidentally, most applications today that require fault tolerance or redundancy also require Hot-Swap capability to ensure continuous system operation. Hot-swappable cards must be designed so the operator won't come in contact with dangerous potentials and currents.

It's also essential that when a module fails, the failure is detected and identified by an alarm or notice to provide service. A Hot-Swap system must ensure that during swap-out, there is minimal disturbance of the power bus. Specifically, the affected voltage bus must not drop enough to cause errors in the system, either on the input bus or the output bus.

A power-supply failure can cripple an entire system, so the addition of a redundant converter or supply is often justified by the need to keep the system operating. Adding an extra module (N+1) to a group of paralleled modules will significantly increase reliability with only a modest increase in cost.

The implementation of redundant converters is determined in part by the available space and cost requirements. For example, two

200W full-size modules could be used to provide a 400W output with an additional 200W module for 2+1 redundancy (a total of 600W in a volume of about 16.5in³).

Alternatively, four 100W half-size modules might be used with a fifth 100W module to provide 4+1 redundancy (a total of 500W and 14in³). Although the second solution uses less space, it increases the accumulated failure rate because it employs more converters, more ORing diodes, more monitoring circuitry and more assembly.

ORing diodes may be inserted in series with the output of each module in an N+1 array to provide output fault tolerance. (Figure 8.2) They're important in a redundant power system to maintain fault isolation. Without them, a short-circuit failure in the output of one converter could bring down the entire array.

But ORing diodes add losses to the power system, reducing overall efficiency and decreasing reliability. To ameliorate the negative effect on efficiency, ORing diodes should run hot, thereby reducing forward voltage drop and increasing efficiency. Reverse-leakage current will be an issue only if the output of a converter shorts and the diode is reverse biased. This is an important consideration with regard to operating temperature.

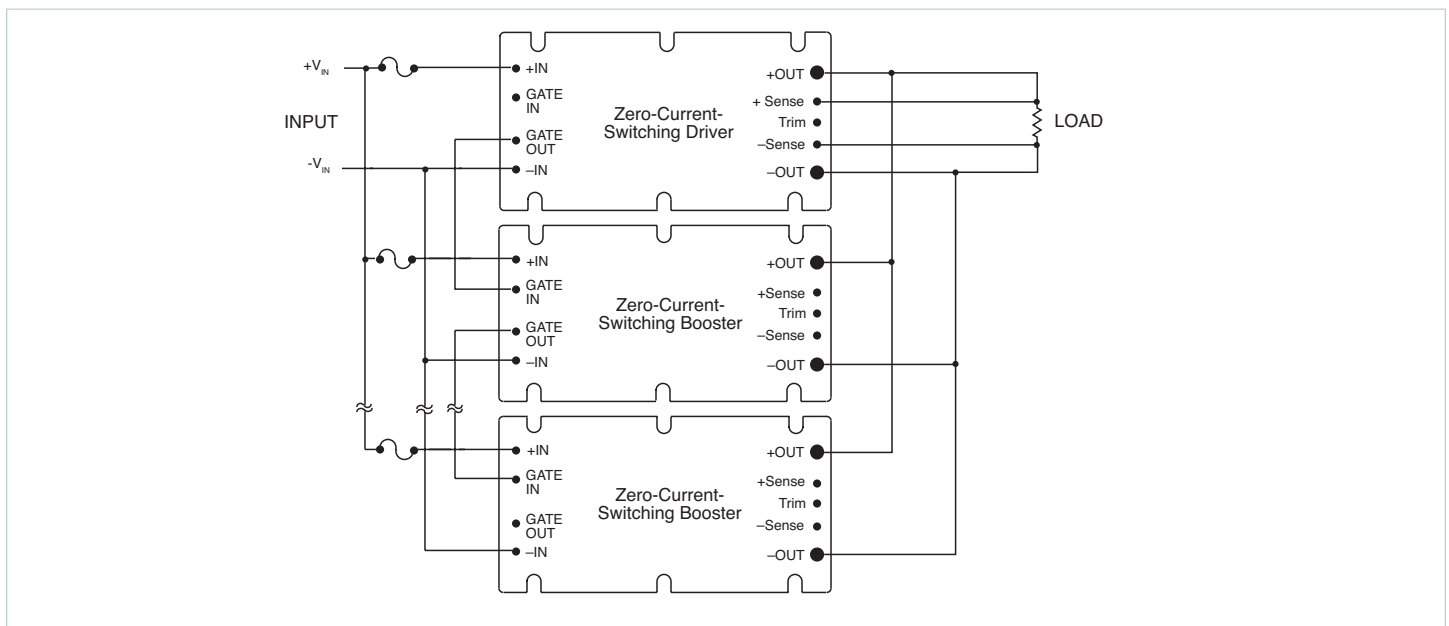

Figure 8.3 — Most converters can use the Driver / Booster array to increase output power. Driver / Booster arrays usually contain one intelligent module or Driver and one or more powertrain-only modules or Boosters

Conducted Noise

Conducted noise is the AC current flowing between the source voltage and the power supply. It includes both common-mode and differential-mode noise. Vicor zero-current-switching converters are 20 – 40dB lower in conducted noise than a traditional board-mounted PWM converter; however, if a specific EMC specification such as FCC or VDE must be met, additional filtering may be required.

Since the noise generated is ten to a hundred times lower than fixed-frequency converters, an existing filter should provide equal or better performance when the conditions in the [Module Dos and Don'ts](#) section are followed. (Section 3)

In the event the system does not contain an existing filter, the following will provide valuable information relative to the attainment of system conducted noise objectives. System requirements, such as Tempest (military) or UL544/ EN60601 (medical), require a somewhat different approach. Medical requirements vary as a function of the application and country – please contact Vicor Applications Engineering for additional details.

Common-Mode Noise with No Additional Filtering: Common mode conducted-noise current is the unidirectional (in phase) component in both the +IN and –IN pins to the module. This current circulates from the converter via the power input leads to the DC source and returns to the converter via the grounded baseplate or output lead connections. This represents a potentially large-loop cross-sectional area which, if not effectively controlled, can generate magnetic fields. Common-mode noise is a function of the dV/dt across the main switch in the converter and the effective input to baseplate and input to output capacitance of the converter.

The most effective means to reduce common-mode current is to bypass both input leads to the baseplate with Y-capacitors (C2), keeping the leads short to reduce parasitic inductance. Additionally, a common-mode choke (L1) is usually required to meet FCC/VDE A or B. (Figure 9.2)

NOTE: Acoustic Noise. Audible noise may be emitted from the module under no load, light-load or dynamic-loading conditions. This is considered normal operation of the module.

Typical Vicor Module 48V Input, 5V Output (VI-230-CV)

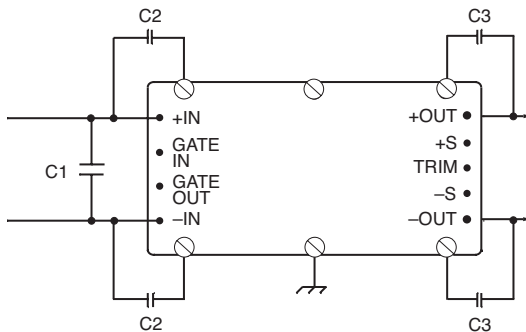

C1 = 100µF
 C2 = 4,700pF
 C3 = 0.01µF
 Nominal Line = 48V

Conditions:
 Light Load = 3A
 Nominal Load = 15A
 Full Load = 30A

Conducted Noise vs. Load

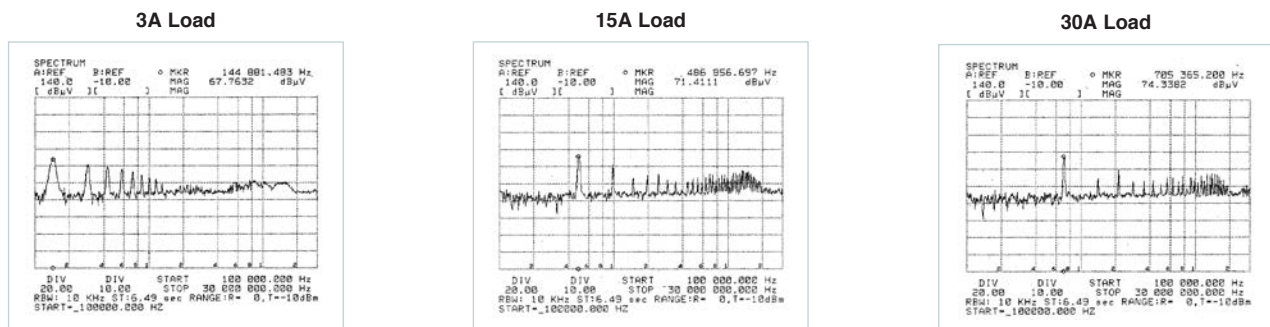

Figure 9.1 — Conducted input noise, no additional filtering

Common-Mode Noise with Common-Mode Choke: There are no special precautions that must be exercised in the design of input filters for Vicor converters. In fact, if the system contains an EMC filter designed for typical fixed-frequency converters, it should be sufficient as is (although not optimal in terms of size), as zero-current-switching converters inherently generate significantly less conducted noise.

Note: In most cases, a fixed-frequency converter generates more input conducted noise with a filter than Vicor zero-current-switching converter without a filter. Also note that fixed-frequency converters using a construction technique involving control circuitry on the same metal plate as power processing components will generate significantly more input noise than shown.

The plots in Figure 9.2 are representative of fixed frequency converters with input filtering.

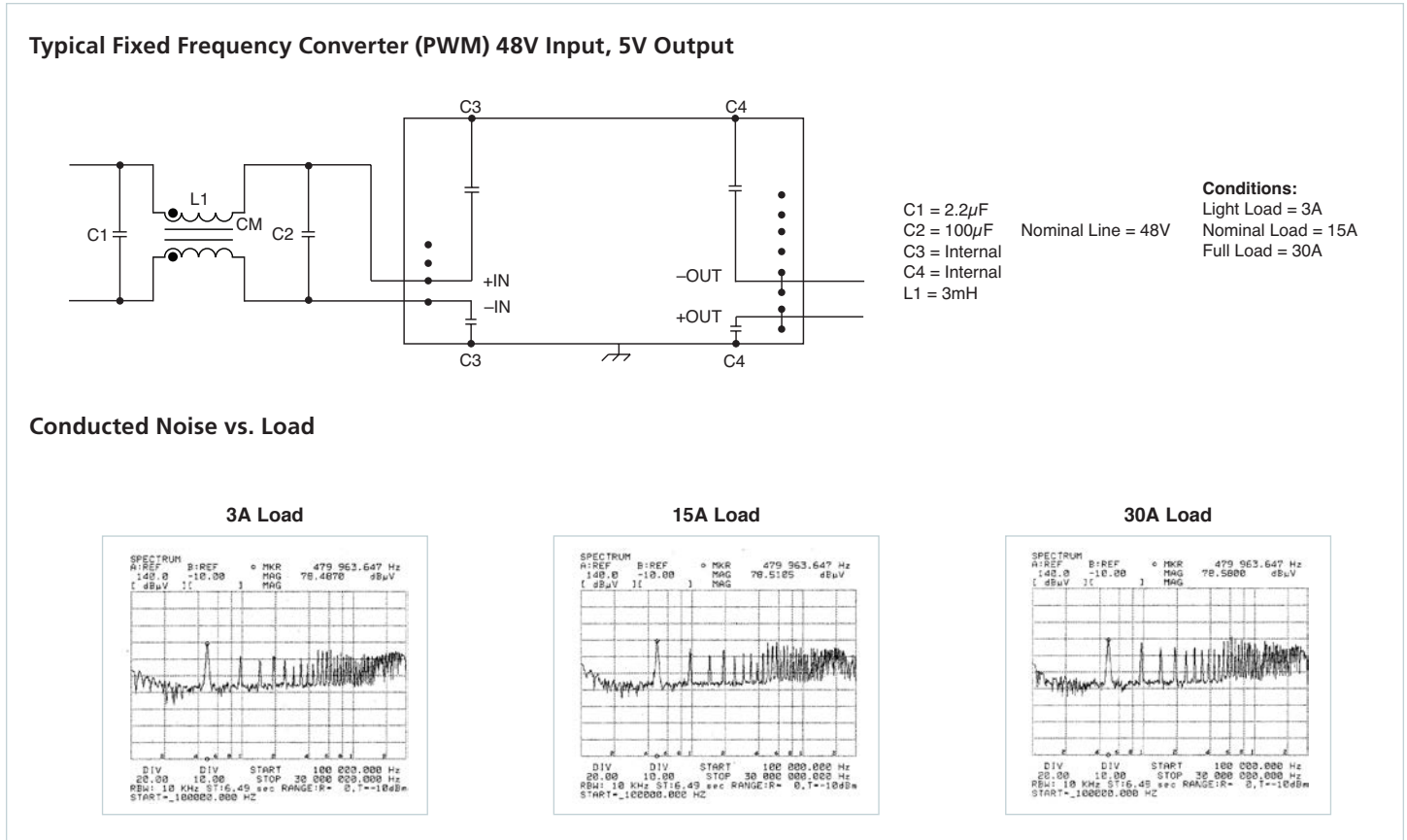
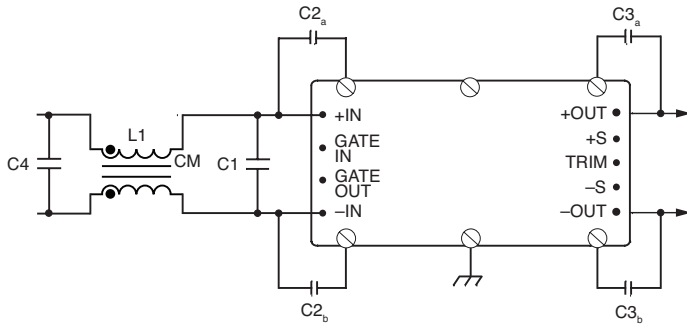

Figure 9.2 — Conducted input noise, typical fixed frequency converter with filter

Typical Vicor Module (VI-230-CV) 48V Input, 5V Output



- C1 = 100µF
- C2_a - C2_b = 4,700pF (Vicor Part # 01000)
- C3_a - C3_b = 0.01µF (Vicor Part # 04872)
- C4 = 2.2µF
- L1 = 3,000µH (Vicor Part # 31742)

Conditions
 Light Load = 3A
 Nominal Load = 15A
 Full Load = 30A

Three common-mode chokes are offered as standard accessories:

Part Number	Inductance Each Winding	Maximum DC Current	Resistance Each Winding
31743	1,000µH	12 Amperes	6.5mΩ
31742	3,000µH	7 Amperes	18mΩ
31943	2,163µH	1 Ampere	42mΩ

NOTE: Common-mode filters may be common to one or more modules, but only one should be used with modules interconnected via GATE IN's or, GATE OUT to GATE IN. As an example, Driver / Booster arrays or Drivers with GATE IN's tied together to provide a common disable function.

Conducted Noise vs. Load

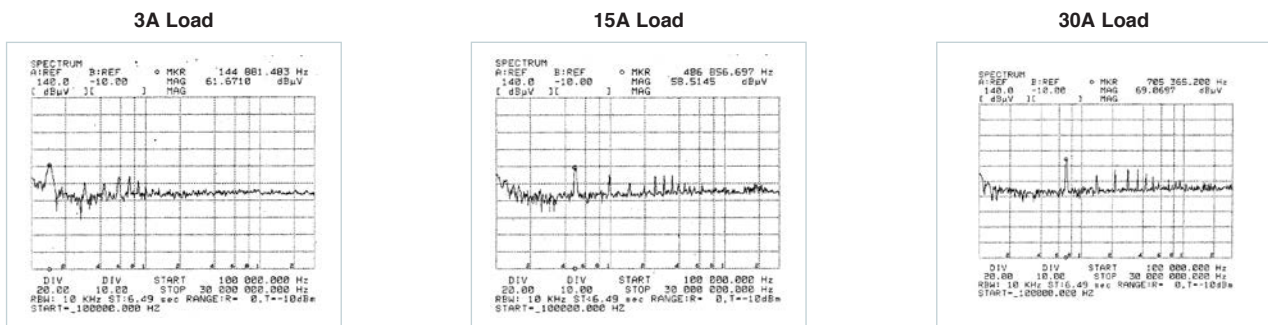
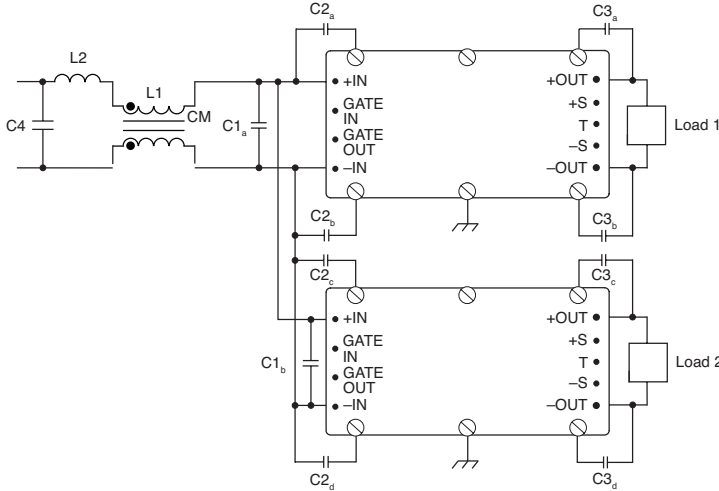

Figure 9.3 — Conducted input noise, with common-mode choke

Differential and Common-Mode Filter with More than One Module: No special precautions are needed when using two or more modules. The filter required will have the same characteristics as a single-module filter, however the wire size on the magnetics

will need to reflect the increased input current. Shown below is the input-conducted noise for two modules sharing a common-input source.

Typical Vicor Module (VI-230-CV) 48V Input, 5V Output



- C1_a – C1_b = 47µF
 - C2_a – C2_d = 4,700pF (Vicor Part # 01000)
 - C3_a – C3_d = 0.01µF (Vicor Part # 04872)
 - C4 = 2.2µF
 - L1 = 3,000µH (Vicor Part # 31742)
 - L2 = 20µH
- Conditions**
 Light Load = 3A
 Nominal Load = 15A
 Full Load = 30A

Three common-mode chokes are offered as standard accessories:

Part Number	Inductance Each Winding	Maximum DC Current	Resistance Each Winding
31743	1,000µH	12 Amperes	6.5mΩ
31742	3,000µH	7 Amperes	18mΩ
31943	2,163µH	1 Ampere	42mΩ

NOTE: Common-mode filters may be common to one or more modules, but only one should be used with modules interconnected via GATE IN's or, GATE OUT to GATE IN. As an example, Driver / Booster arrays or Drivers with GATE IN's tied together to provide a common disable function.

Conducted Noise vs. Load

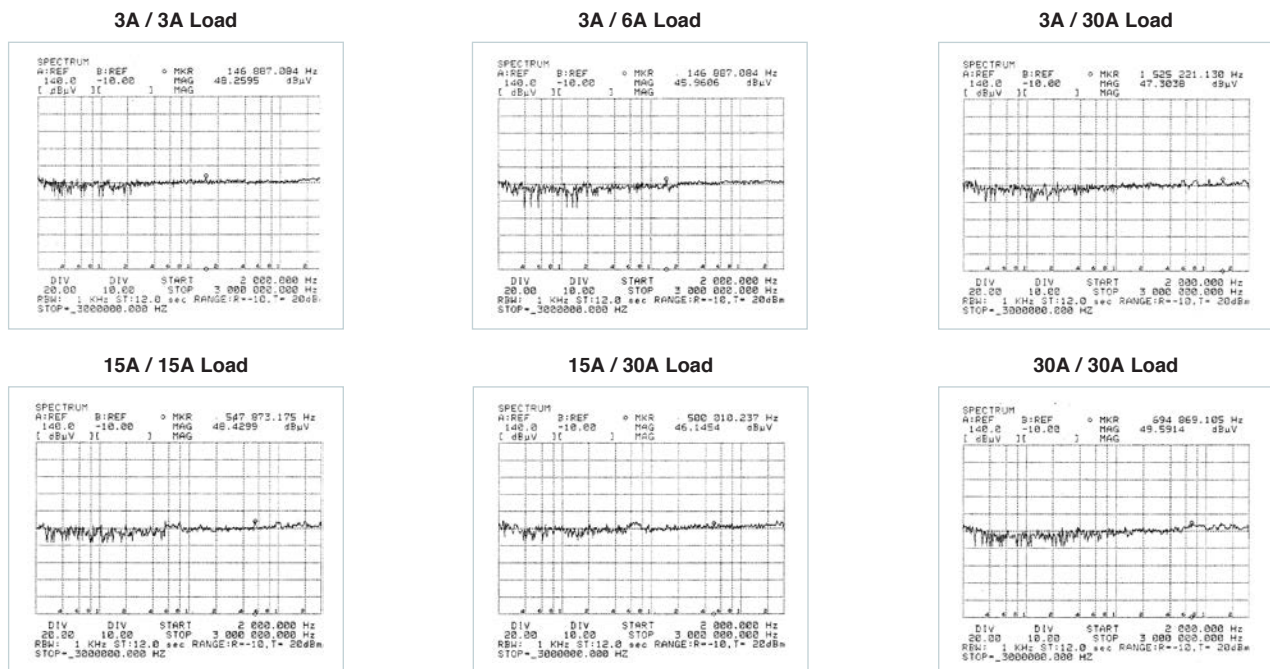

Figure 9.4 — Conducted noise, multiple zero-current-switching converters

Differential-Mode Noise Filter: Differential-mode conducted noise current is the component of current, at the input power pin, which is opposite in direction or phase with respect to the other input power pin.

All Vicor converters have an internal differential-mode LC filter which, in conjunction with a small external capacitor

$$C1 \text{ (minimum value in } \mu\text{F)} = 400 / V_{IN}$$

reduces differential-mode conducted noise. The external capacitor should be placed close to the module to reduce loop cross-sectional area.

Care should be taken to reduce the loop cross-sectional area of differential-mode current flowing between the source and C1. Since differential-mode input current is by definition opposite in phase, twisting the input leads causes noise cancellation. PCB power planes can reduce radiated noise if the traces are on opposite sides of the PCB directly over one another. If differential-mode inductance is used, it may be common to one or more modules.

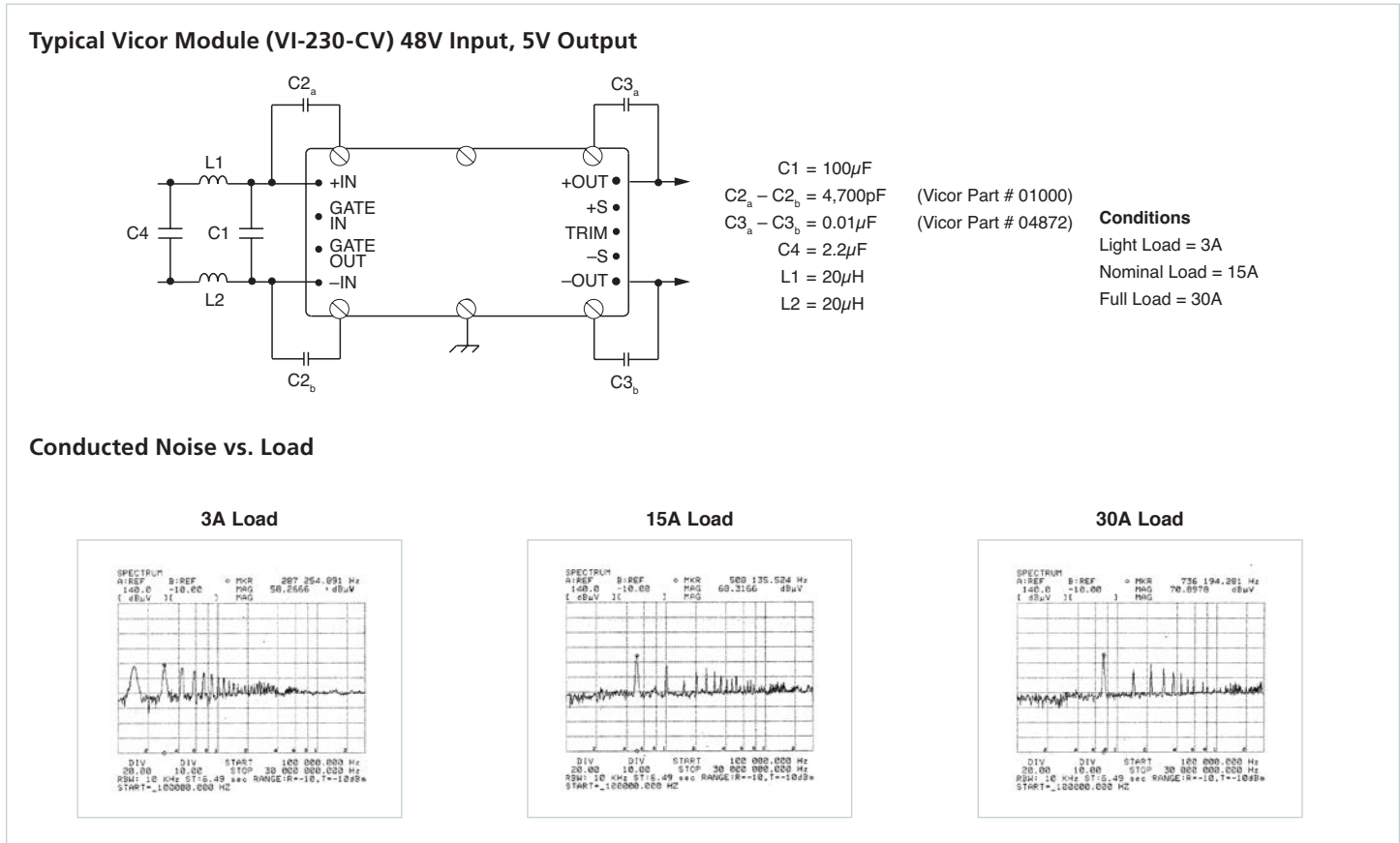

Figure 9.5 — Conducted noise, differential-mode filtering

Radiated Noise

Radiated noise may be either electric field or magnetic field. Magnetic radiation is caused by high di/dt and is generally what is measured by FCC, VDE or MIL-STD-461. Vicor converters utilize zero-current-switching, with the advantage over PWM non-zero-current-switching being that zero-current-switching topologies contain minimal discontinuities in the switched-current waveforms, resulting in lower di/dt 's. Electric-field radiation (caused by dv/dt) is "near-field," i.e., it decays rapidly as a function of distance and as a result does not typically affect radiated measurements.

Radiation can be minimized by proper board layout. Keep all leads with AC current short, twisted or routed as overlapping planes to minimize loop cross-sectional area.

Also keep in mind the effects of capacitive coupling – even when not expected. Do not put an unshielded filter on the opposite side of the PCB from the module. Conducted noise can be capacitively coupled around the filter. Do not route input and output leads in the same cable bundle. Again, no special precautions, just good design practice.

Noise Considerations

All switchmode power supplies generate a certain amount of "noise", yet it remains one of the least understood parameters in power conversion.

VI-200s and VI-J00s both use the same topology, so their operation is very similar. These products are zero-current-switching converters – i.e., the current is zero when the main switch is turned on or off. While the switch is on, the current through the switch or the primary of the transformer is a half-wave rectified sine wave. Similar in operation to a resonant converter, these products are commonly referred to as quasi-resonant converters. The LC resonant frequency is fixed so the on-time of the switch is about 500ns. When the switch turns on, energy builds up in the leakage inductance of the transformer (L) and then "transferred" into the capacitor on the secondary side of the module. (C, Figure 9.6) The energy processed in each pulse is fixed and is ultimately the energy stored in this capacitor, $1/2 CV^2$. Since the energy in every pulse is fixed, the repetition rate of the pulse train is varied as a function of load to regulate the output voltage. Maximum-repetition rate occurs at minimum line, full load and is approximately twice the LC time period or $1\mu s$. If the load drops by 50%, then the repetition rate is approximately one-half of maximum (since the energy in every pulse is fixed). Therefore the pulse-repetition rate varies linearly with load, to a first-order approximation.

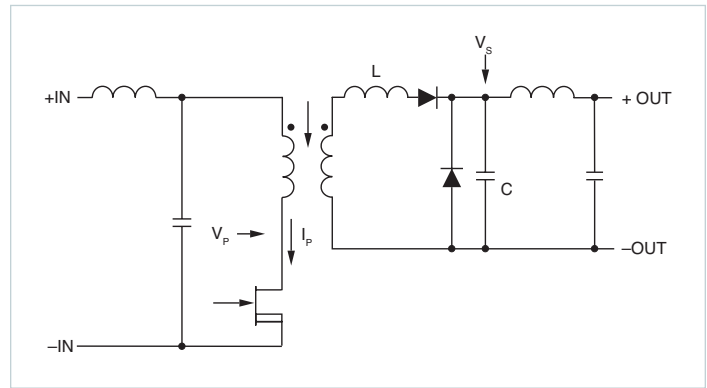

Figure 9.6 — Basic zero-current-switching converter topology (VI-200 / VI-J00)

Since the energy in every pulse is related to the square of the applied voltage (CV^2), the pulse repetition rate varies as approximately the square of the line voltage. For example, a 300V input unit can vary from 200 – 400V, or a factor of two, therefore it follows that the repetition rate must vary by approximately a factor of four to regulate the output. As previously established, the current in the primary is a half-wave rectified sine wave, but the voltage on the primary is a square wave. Since this voltage is a square wave, it contains harmonics of the fundamental switching frequency. It also includes frequencies, that extend to 70MHz.

These frequencies can be of interest in the following circumstances. Rapidly changing voltages (high dv/dt) can generate E-fields (primarily near-field) which do not usually cause system noise problems since they significantly decrease as a function of distance. For this reason, E-fields are not measured by agencies such as the FCC or VDE. These agencies do, however, measure the magnetic radiation caused by high-frequency currents in a conductor. The half-wave rectified sine wave in the transformer is an example of this, but since there are minimal discontinuities in the current waveform and the loop cross-sectional area is very small, the resultant E-field is very small. E-fields can be a problem if sensitive circuitry is located near the module. In this case, a shield can be positioned under the label side of the module as a discrete element or as a ground plane on the PCB. The other effect that occurs as a result of the 50 – 70MHz component on the main switch is common-mode noise. (Figure 9.7)

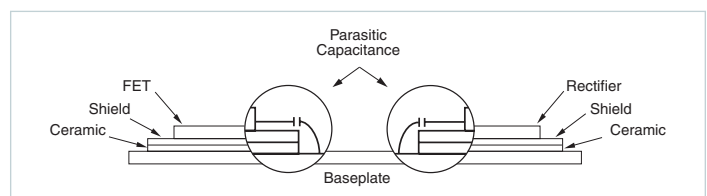

Figure 9.7 — The shield layer serves to reduce the capacitance

The dV/dt of the switch (FET) is a noise generator. This FET is mounted on a two-layer insulating and shielding assembly which is attached to the baseplate. Since ceramic is a dielectric, there is capacitance from the FET to the baseplate. (Figure 9.7) The output rectifiers are also tied to the baseplate with ceramic insulators, adding additional capacitance. The dV/dt of the FET is differentiated by these two series capacitors, resulting in a spike of noise current at 50 – 70MHz that flows from primary to secondary. (Figure 9.8) This noise current is common-mode as opposed to differential and therefore should not affect the operation of the system. It should be noted, however, that oscilloscopes have a finite ability to reject common-mode signals and these signals can be abnormally emphasized by the use of long ground leads on the scope probe.

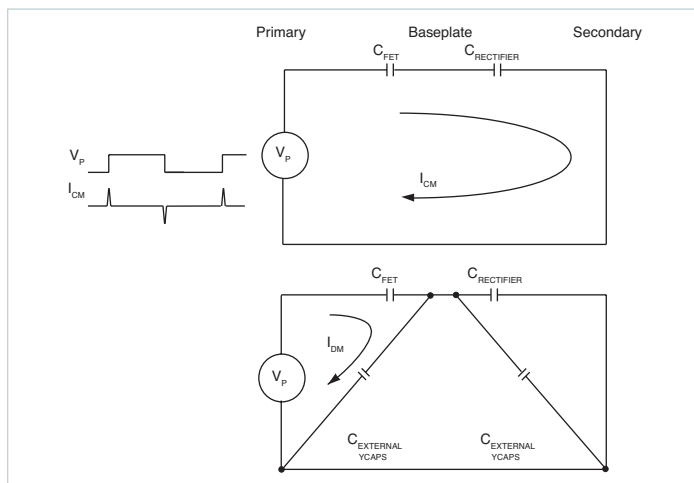

Figure 9.8 — Noise coupling model

Measuring Output Noise

Long ground leads adversely impact the common-mode rejection capability of oscilloscopes because the ground lead has inductance not present on the signal lead. These differing impedances take common-mode signals and convert them to differential signals that show up on the trace. To check for common-mode noise, place the oscilloscope probe on the ground lead connection of the probe while the ground lead is tied to output return. (Figure 9.9) If the noise is common-mode, there will still be “noise” observed at the same test point.

Note: The output return must be at the same relative potential as the earth ground of the oscilloscope or damaging current may flow through the oscilloscope ground lead.

Capacitors are required from the $+/-IN$ to the baseplate thereby shunting common-mode current, thus reducing noise current on the input power lines. The capacitor must have very short leads since the frequency is high. It must also be a good capacitor (i.e., ceramic or other material that has a low ESR / ESL). This type of capacitor is most important on high-input-voltage units since the “ dV ” is larger, but is required for all units. For off-line applications this capacitor must have the appropriate safety agency approvals.

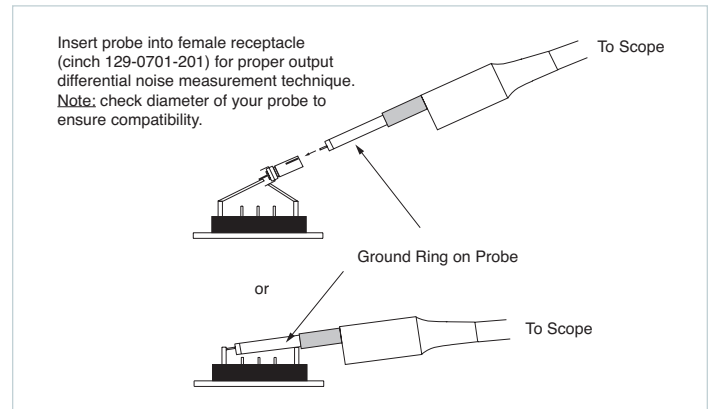

Figure 9.9 — Output ripple measurement technique

A capacitor from $+/-V_{OUT}$ to the baseplate, is required since the output rectifier has a changing voltage on it and, like the FET, can generate common-mode noise. This capacitor is similarly recommended for high-output voltage units (48V).

Common-mode noise is not differential with respect to the output. It does, however, flow in both input and output leads of the power supply and is a noise parameter that is measured by the FCC or VDE. It can cause power systems to fail radiated emission tests, so it must be dealt with. Bypass capacitors to the baseplate with a common-mode filter on the input of the module or the main input of the power supply is required.

The common-mode filter is typically placed on the input as opposed to the output. Theoretically, since this current flows from primary to secondary, the choke could be placed in either the input or the output, but is preferably placed in the input leads for the following reasons:

1. input currents are smaller since the input voltage is usually higher;
2. line regulation of the module can correct for voltage drops across the choke; and
3. if the choke is on the output and the senses are connected to the other side of it, the stability of the loop may be impacted.

Differential output noise is the AC component of the output voltage that is not common to both outputs. The noise is comprised of both low-frequency, line-related noise (typically 120Hz) and high-frequency switching noise.

High-Frequency Switching Noise: Peak-to-peak output voltage ripple is typically 2% or less (1% for 12V outputs and above). Hence additional output filtering is generally not required. Digital systems rarely need additional filtering. However some analog systems, such as ultrasound systems, will probably require additional output filtering. See additional output filter choices in Table 9.1.

Line-Related Output Noise: Line-related output noise can be determined from the converter specification –Input Ripple Rejection. As an example, a VI-260-CV

Output Filter Option	5V Outputs	12 – 15V Outputs	24 – 48V Outputs
No Additional Filter	2% P-P (Typical)	1% P-P (Typical)	0.2% P-P (Typical)
Low ESR Output Cap.	1% P-P (Typical)	0.5% P-P (Typical)	0.1% P-P (Typical)
LC Output Filter	0.4% P-P (Typical)	0.2% P-P (Typical)	0.05% P-P (Typical)
RAM Filter (VI-200)	<3mV _{p-p} (Maximum)	<3mV _{p-p} (Maximum)	<3mV _{p-p} (Maximum)
RAM Filter (VI-J00)	<10mV (Maximum)	<10mV (Maximum)	<10mV (Maximum)

Table 9.1 — Output filter options and output voltage and ripple

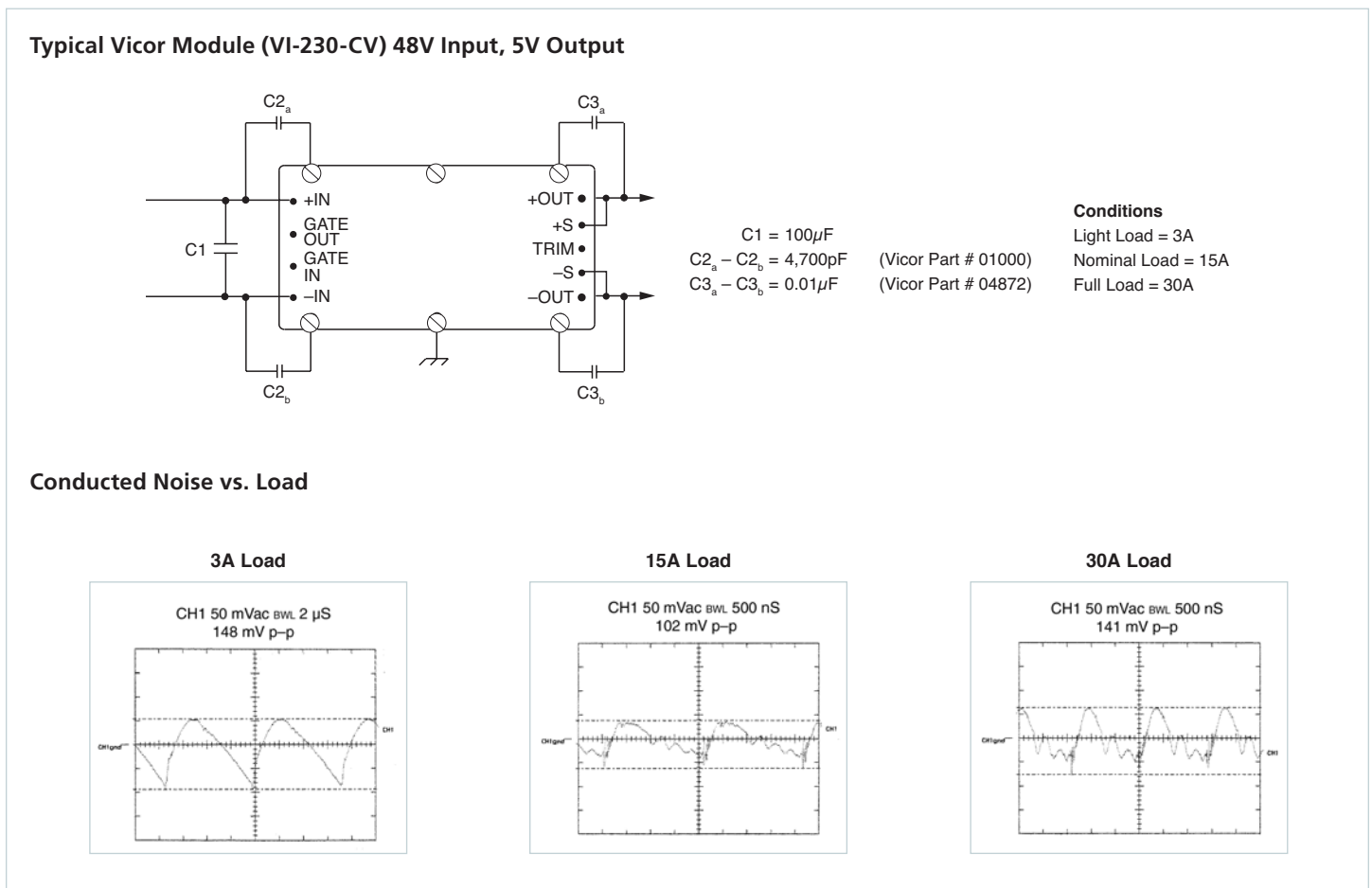
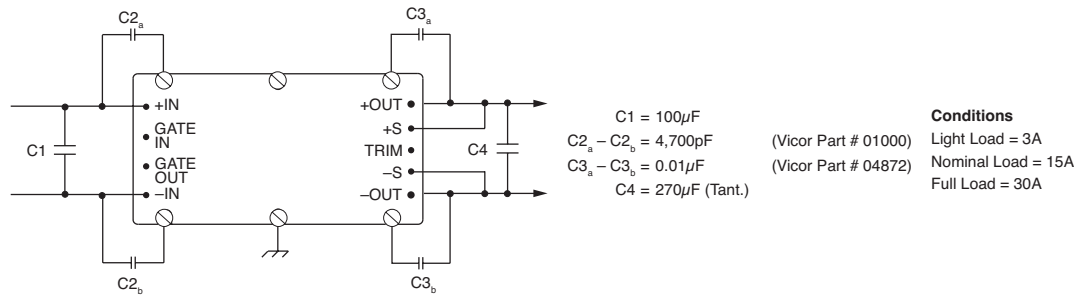

Figure 9.10 — Output noise, no additional output filtering

Addition of Output Capacitor Typical Vicor Module (VI-230-CV) 48V Input, 5V Output



Conditions
 Light Load = 3A
 Nominal Load = 15A
 Full Load = 30A

NOTE:
 A low-ESR capacitor should be used on the output, preferably tantalum.

Output Ripple vs. Load

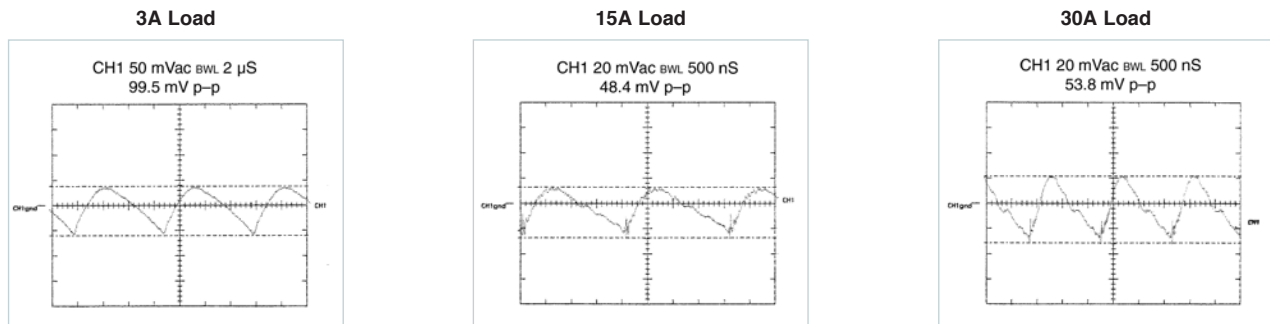
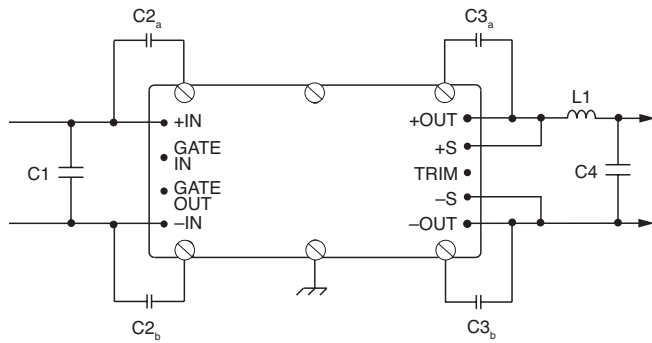

Figure 9.11 — Output noise, additional output capacitance

LC Output Filter Typical Vicor Module (VI-230-CV) 48V Input, 5V Output



- C1 = 100 μ F
- C2_a - C2_b = 4,700pF
- C3_a - C3_b = 0.01 μ F
- C4 = 270 μ F
- L1 = 200nH

- (Vicor Part # 01000)
- (Vicor Part # 04872)
- (Tant.)
- (Vicor Part # 30268)

- Conditions**
- Light Load = 3A
 - Nominal Load = 15A
 - Full Load = 30A

Output Ripple vs. Load

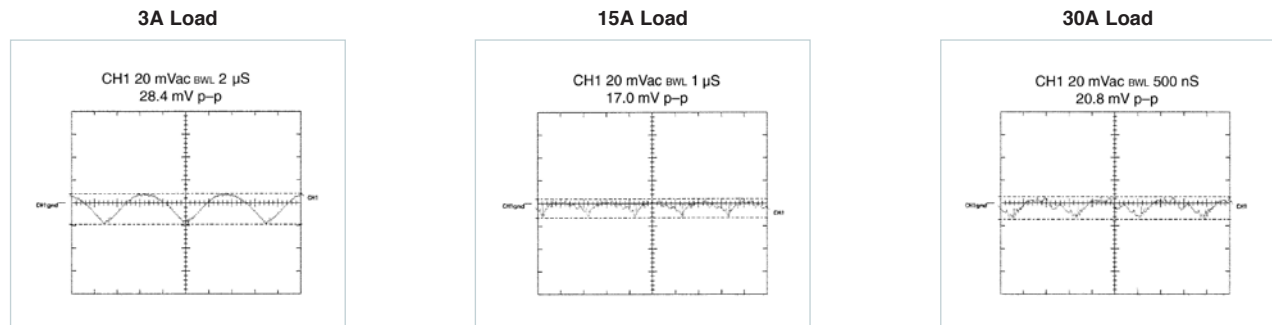

Figure 9.12 — Output noise, additional output inductor and capacitor (L-C Filter)

($300V_{IN}$ to $5V_{OUT}$) has a rejection specification at 120Hz of $30 + 20 \text{ Log}(V_{IN} / V_{OUT})$. $V_{IN} = 300$ and $V_{OUT} = 5$, hence its rejection is $30 + 35.56 = 65.56\text{dB}$, which provides an attenuation factor of 1.89k. Therefore, if the input to the converter has $30V_{p-p}$ of ripple, the output p-p ripple would be 15.8mV. It is not practical to attenuate this component further with passive filtering due to its low frequency, hence active filtering is required. The RAM contains both a passive filter for high-frequency noise and an active filter for low-frequency noise.

RAM / MI-RAM Operation

The RAM/MI-RAM attenuates output noise in two ways. First, an LC filter in the RAM / MI-RAM attenuates high-frequency components associated with the switching frequency. Secondly, the RAM / MI-RAM contains an active filter that attenuates low-frequency components associated with the input to the converter. These frequencies are on the order of 60 – 120Hz and harmonics would require very large output LC if a passive approach were to be used. Essentially, the active circuit looks at the output ripple from the converter, multiplies it by -1 (inverts) and adds it to the output. This effectively cancels out the low frequency components.

The RAM does not contain any common-mode filtering, so whatever common-mode noise is present is passed through. It only provides differential filtering of noise that is present on one output pin relative to the other.

The use of the RAM / MI-RAM is very straightforward, but a couple of precautions should be noted. The LC filter is in the positive-output lead, so if that lead is shorted then the high-frequency attenuation is compromised. The active circuit is in the negative-output lead, so if that lead is shorted the low-frequency attenuation is compromised. The RAM must be used with a common-mode choke at the input of the converter.

The RAM is intended to be used with the Vicor VI-200 / VI-J00, and the MI-RAM is intended to be used with Vicor MI-200 / MI-J00 Family of DC-DC converter modules. It is also available in a chassis-mounted version as VI-LRAM-xx (MegaMod package) or VI-RAM-xx-B1 (BusMod package).

NOTE: Do not use if load is inductive as instability may result. The addition of the RAM will increase the converter’s current-limit setpoint by ~ 14%.

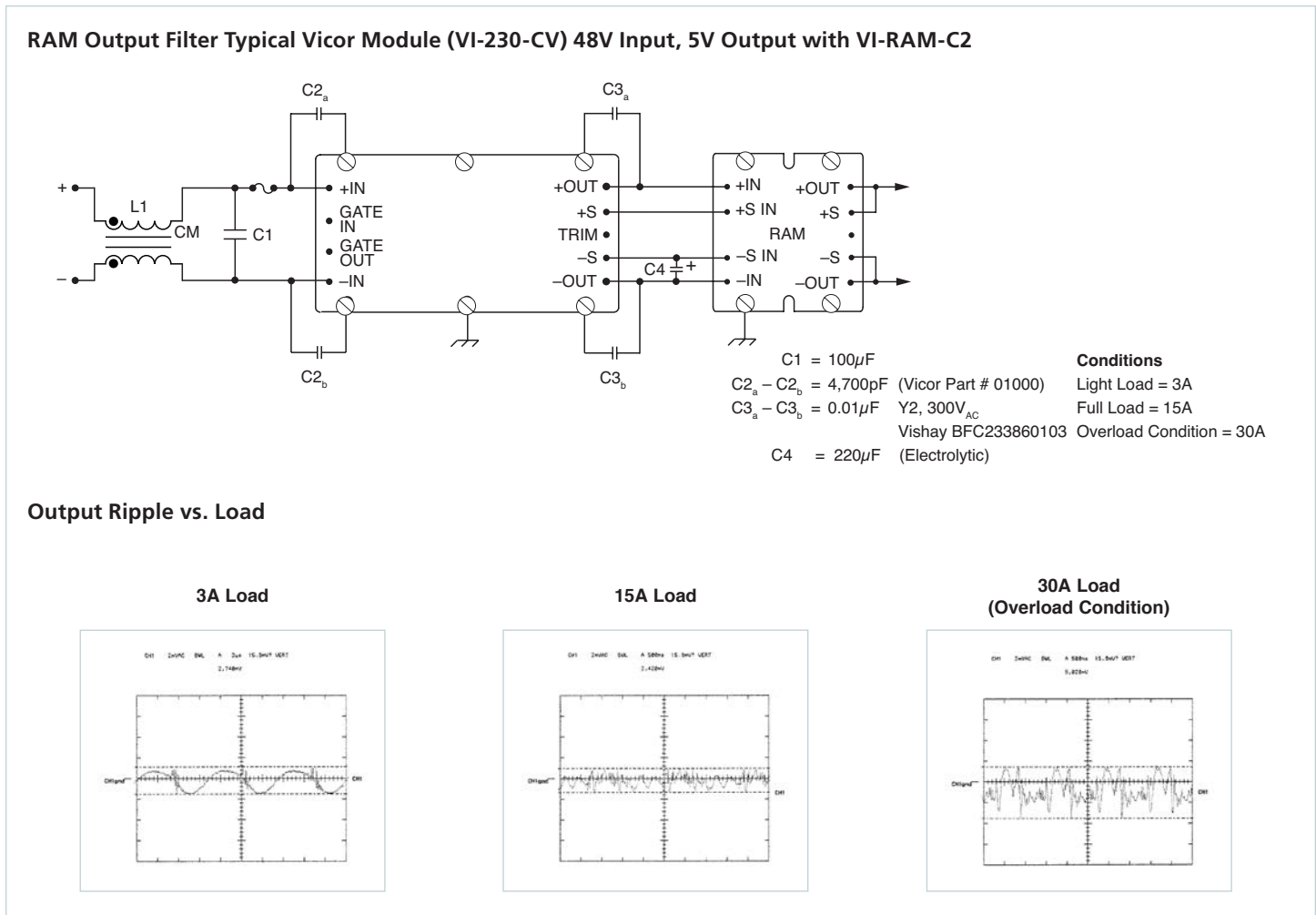

Figure 9.13 — Output noise, with Ripple Attenuator Module (RAM)

Overview

The LC filter design below is a comparatively simple solution for reducing ripple on the outputs of the Vicor VI-200 and VI-J00 Family converter modules. These components are small and provide significant peak-to-peak noise attenuation. Since an output filter capacitor is already present in the DC-DC converter, adding an inductor and capacitor to the output creates a pi filter. It is important that the inductor wire be of a size sufficient to carry the load current, including a safety factor and that the core does not saturate. LC filters are generally needed only where very accurate analog signals are involved.

The RAM / MI-RAM (Ripple Attenuator Module) should be used if greater attenuation of output ripple is required or where additional AC power line-ripple frequency rejection is required.

All standard outputs will function with either remote sense or local sense, with the recommended capacitance. Lower ESR is achieved with capacitors in parallel. Ripple data measured at 20MHz bandwidth limit.

Adding excessive amounts of external filtering may compromise the stability of the converter and result in oscillation.

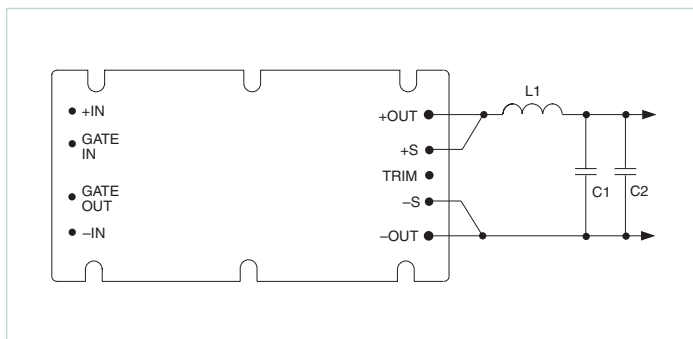

Figure 10.1 — Recommended LC output filter

Filter Components for 5V Output

- L1 — Vicor P/N 30268 or Micrometals #T38-26/90 core with 2T #14 wire (200nH)
- C1, C2 — Vicor P/N 30800, 270 μ F / 10V, solid tantalum, ESR 90m Ω typical
- Typical data at high line input: With full load, ripple ~ 11mV_{p-p}
With 50% load, ripple ~ 8mV_{p-p}

Filter Components for 12V and 15V Outputs

- L1 — Vicor P/N 30268 or Micrometals #T38-26/90 core with 2T #14 wire (200nH)
- C1, C2 — Vicor P/N 30506, 120 μ F / 20V, solid tantalum, ESR 90m Ω typical
- Typical data at high line input: With full load, ripple ~ 5mV_{p-p}
With 10% load, ripple ~ 15mV_{p-p}

Filter Components for 24V and 28V Outputs

- L1 — Vicor P/N 30268 or Micrometals #T38-26/90 core with 2T #14 wire (200nH)
- C1, C2 — 68 μ F / 30V, solid tantalum, ESR 160m Ω typical
- Typical data at high line input: With full load, ripple ~ 6mV_{p-p}
With 10% load, ripple ~ 18mV_{p-p}

Overview

The BatMod is a programmable current-source module that is intended for battery charging or similar current-source applications. It can be controlled externally to meet a wide range of charging parameters: voltage, current, charge rate and charge time.

The BatMod is comparable to the VI-200 voltage-source module but with a variable current limit. It has three output pins that differ from the VI-200 converters: Current Control (I_{TRIM}), Voltage Adjust (V_{TRIM}) and Current Monitor (I_{MON}). All of these pins are referenced to the -OUT pin.

Although the BatMod is primarily intended for battery-charge applications, it can be used as a programmable-current source for resistive loads or CW laser diodes. The BatMod will not function properly at zero- output voltage and current simultaneously. It follows therefore, that the current can not be adjusted to zero with a resistive load. Refer to Safe Operating Area Curves on the [BatMod data sheet](#), which can be found at vicorpower.com.

Pinout Description

Current Control (I_{TRIM}): An input which can receive an analog control voltage from 1 – 5V for adjustment of the sourced current from zero to maximum rating of the BatMod.

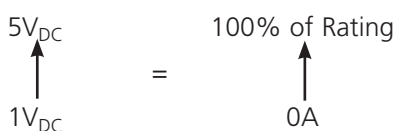

Voltage Adjust (V_{TRIM}): An input for controlling or setting the output setpoint, this is similar to the trim function on the VI-200. (Section 5) A maximum voltage can be set by a fixed resistor or adjusted with an external voltage source. A source voltage referenced to -OUT adjusted from 1.25 – 2.5V will program a 50 – 100% of rated voltage setting.

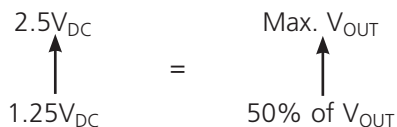

It is important to note the nominal output voltage for each BatMod type untrimmed.

12V _{OUT} Part #	=	15V actual
24V _{OUT} Part #	=	30V actual
48V _{OUT} Part #	=	60V actual

Current Monitor (I_{MON}): An output that indicates the amount of current being sourced. It is a linear voltage / current relationship where one volt corresponds to 0% of sourced current and 5V corresponds to 100% of sourced current.

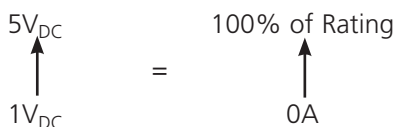

For DC input / current source applications (Figure 11.1), the BatMod has a similar wide range input rating as the VI-200 Family of voltage converters for 48 and 300V inputs. BatMods can be used for higher-current source applications with a Driver / Booster approach. (Figure 11.2)

NOTE: Inductance to the load should be limited to 20μH to avoid possible loop instabilities.

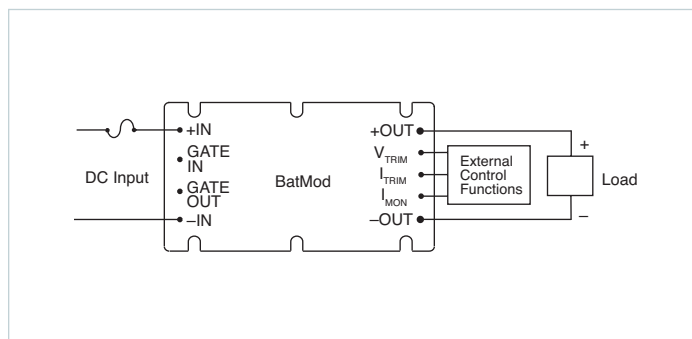

Figure 11.1 — DC input single module

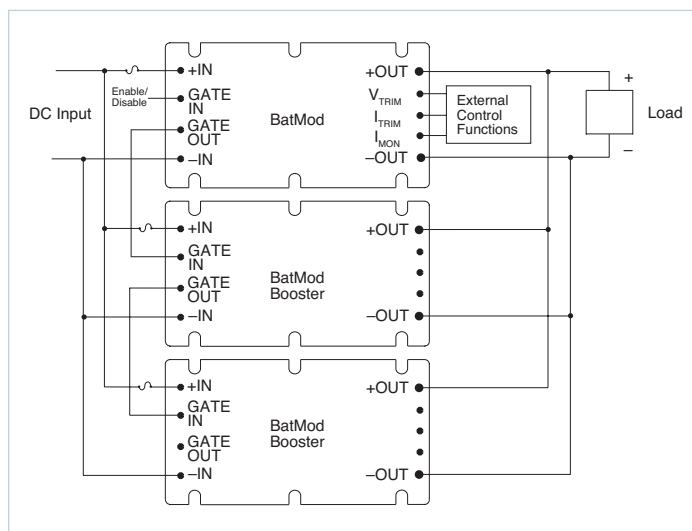

Figure 11.2 — DC input high power array

Designing a Battery Charger

The Vicor BatMod (current-source module) enables designers to easily build a compact, lightweight battery-charging system with commonly available parts. The BatMod provides programmable output current and output voltage capability. Since the BatMod allows the output voltage and the charge current to be set independently, the system design is greatly simplified.

Basic Battery Charger: Figure 11.3, shows a basic charging circuit with a BatMod for the following system requirements:

Battery voltage: 12V
 Float voltage: 13.8V
 Charge current: Adjustable 0 – 14.5A

Setting the Float Voltage: Since the open circuit output of a 12V BatMod (VI-2x1-CU-BM) is 15V, a trim resistor (R3) is necessary to set the float voltage of 13.8V.

Steps to determine the value of R3:

Solve for V_{TRIM} :

$$\left(\frac{V_{FLOAT}}{V_{NOM}} \right) V_{REF} = V_{TRIM}$$

$$\left(\frac{13.8V}{15V} \right) 2.5V = 2.3V$$

Solve for V_{R5} :

$$V_{REF} - V_{TRIM} = VR5$$

$$2.5V - 2.3V = 0.2V$$

Solve for I_{R5} :

$$I_{R5} = \frac{V_{R5}}{R5} = \frac{0.2V}{10k\Omega} = 20\mu A$$

Solve for R3:

$$\frac{V_{TRIM}}{I_{R5}} = R3$$

$$\frac{2.3V}{20\mu A} = 115k\Omega$$

A 13.8V output requires a 115kΩ resistor.

Setting the Charge Current: The charge current can be programmed from 0 to maximum (14.5A) by applying 1 – 5V to the I_{TRIM} pin. To determine the voltage required to produce a particular charge current, 10A for example, use the following formula:

$$4 \left(\frac{\text{Desired Charge Current}}{\text{Maximum Output Current}} \right) + 1 = I_{TRIM} \text{ Voltage}$$

$$4 \left(\frac{10A}{14.5A} \right) + 1 = 3.76V$$

To set the input voltage at I_{TRIM} to 3.76V, adjust the potentiometer (R2) appropriately.

In Figure 11.3 the configuration will charge the battery at a maximum of 10A with a 13.8V float voltage. Other charge rates and float voltages may be similarly calculated. If a fixed-charge current is desired, the potentiometer can be replaced with two fixed resistors. In applications requiring tight control over the charging current, D1 can be replaced with a precision reference.

Advanced Battery Charger: Many new battery technologies require sophisticated charging and monitoring systems to preserve their high performance and to extend their life. The BatMod serves as an ideal building block for constructing an advanced battery-management system, which typically incorporates a microprocessor-based control circuit that is easily adapted for a variety of battery chemistries and monitoring functions. (Figure 11.4)

To maintain the optimum charge on the battery, the control circuit independently adjusts the float voltage and charge current in response to conditions during the charge: the battery's voltage, current, temperature and pressure and other pertinent parameters. It can also relay battery status information such as capacity, charge and discharge history and cause of failure.

Note: A redundant control or monitoring circuit must be included if failure of the BatMod or its control circuit will result in uncontrolled charging of the battery. Many new battery types are sensitive to these conditions and may result in fire or explosion.

With its wide range of outputs, the BatMod offers designers a simple, cost-effective solution to battery charging for all major battery types.

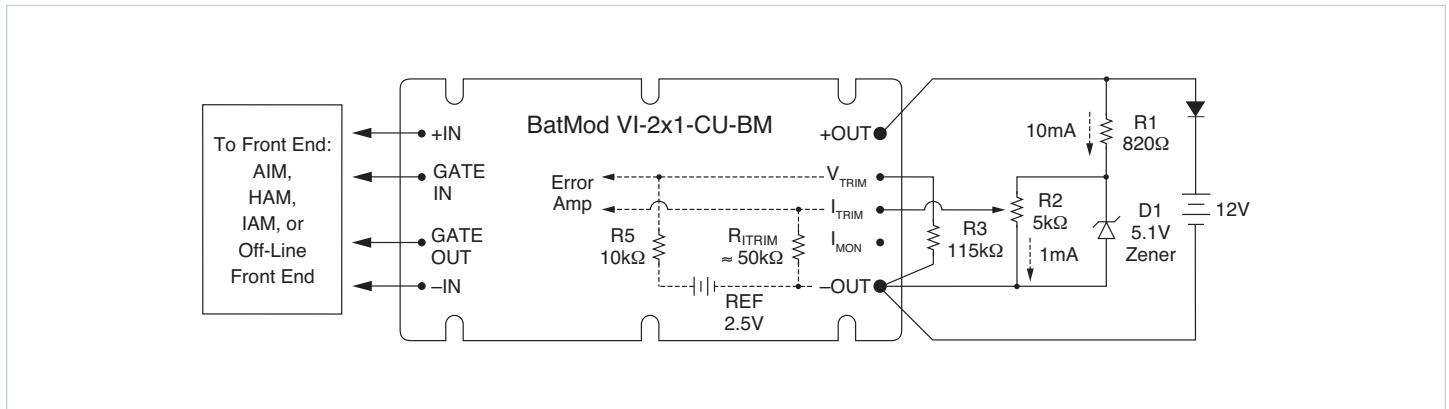

Figure 11.3 — Basic charging circuit using a current source module (BatMod)

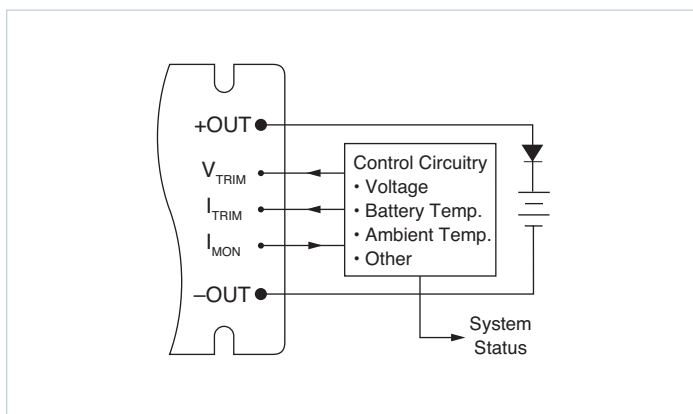

Figure 11.4 — The BatMod in an advanced battery charging system

Overview

In combination with VI-200 and VI-J00 Family of DC-DC converter modules, the Alternating Input Module (AIM) provides a high-density, low-profile, universal AC input off-line switching power supply for systems requiring up to 200W of total output power. The AIM accepts 85 – 264V_{AC}, with a DC output voltage proportional to the peak value of the AC line. The input voltage required for the AIM to start operating is between 82V and 90V_{RMS} (non-distorted sinusoid).

The DC output of the AIM is the peak rectified line ($V_{AC} \text{ RMS} \times \sqrt{2}$), thus, 85V_{AC} corresponds to 120V_{DC} and 264V_{AC} corresponds to 373V_{DC}. Since the DC output range is wide, a “7” (100 – 375V) designator for input voltage in the part number of the DC-DC converter is required. However, the “5” (100 – 200V) designator for the DC-DC converter part number is available for domestic AC inputs only and the “6” (200 – 400V) designator for European AC inputs only, potentially reducing the number of modules required in some applications, based on output power capability.

Summary of Compatible Downstream DC-DC Converters

Use VI-x7x for inputs of 85 – 264V_{AC}; VI-x6x for inputs of 170 – 264V_{AC}; or VI-x5x for inputs of 85 – 135V_{AC}. EMC filtering specifications of FCC Level A are met by adding a 0.47μF “X-type” 0.47μF X2 310V_{AC} capacitor (Vishay F1772-447-2000 or equivalent) to the input of the AIM; “Y-type” bypass capacitors must also be added from the +/- inputs of the DC-DC converters to their respective baseplates, which are grounded (Vicor Part #01000, 4,700pF). To select the hold-up capacitor appropriate for your application, (refer to Selecting Capacitors for AIM Modules section that follows).

The output ripple of the AIM is a function of output load. It is necessary to keep the ripple less than 20V_{p-p} to ensure the under / overvoltage protection circuits will not trigger. A fully loaded AIM (200W of module output power) requires a minimum of 680μF of capacitance; hold-up requirements can be met with this capacitor and maximum total capacitance should not exceed 1,200μF (refer to Selecting Capacitors for AIM Modules section that follows). The voltage rating of this capacitor will be determined by the input operating voltage.

It is necessary to connect all “Driver” DC-DC converter GATE IN pins to the GATE IN pin of the AIM. This GATE IN to GATE IN connection is used to disable the converters at turn-on to allow proper start up of the AIM. The DC-DC converters are then enabled through the GATE IN pin when the output bus voltage is in the range of 113 – 123V_{DC}.

Input overvoltage conditions cause the GATE IN pin of the AIM to disable the converters when the output bus voltage is in the range of 406 – 423V_{DC}. Input undervoltage conditions cause the GATE IN to disable the converters when the output bus voltage drops within the range of 68 – 89V_{DC}.

CAUTION: The AIM is not isolated. Do not place scope probes on input and output of AIM simultaneously. Do not connect the output of the AIM to earth ground.

The GATE OUT of the AIM must be connected to the GATE OUT of only one DC-DC converter. This input signal to the AIM controls a charge pump (D1, D2, C2) that biases the gate of Q1, 10V above its source, which turns on Q1 to shunt out a PTC thermistor that limits inrush. Multiple DC-DC converters operating from an AIM may make it difficult to guarantee a 10% load on the DC-DC converter that provides the GATE OUT signal to the AIM. In this instance, other DC-DC converters can charge pump the FET through the parallel pin, with the addition of two diodes and a capacitor to each Driver module. (Figure 12.4)

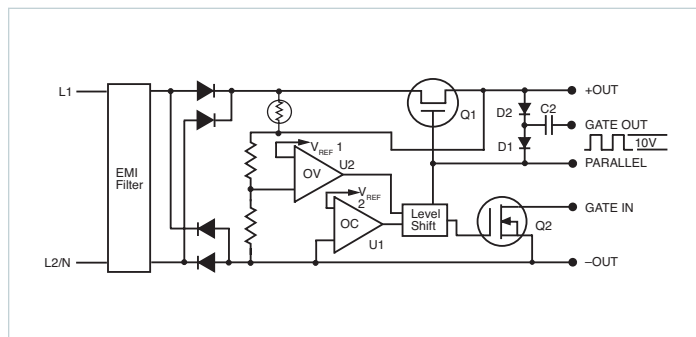

Figure 12.1 — Block diagram, AIM / MI-AIM

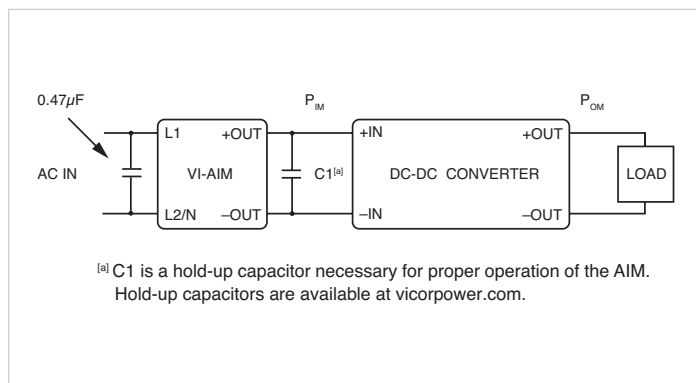

Figure 12.2 — System block diagram
(supervisory connections not shown)

Selecting Capacitors for AIM Modules

Hold-up Time: For maximum flexibility, an external capacitor (Figure 12.2, C1) is used to set the system's hold-up requirements. Hold-up time, for purposes of this application note, is defined as the time interval from loss of AC power to the time a DC-DC converter begins to drop out of regulation (Figure 12.3, T4 to T5). Hold-up time is a function of line voltage, hold-up capacitance, output load and that point on the AC waveform where the line drops out. For example, if the AC line fails just after the hold-up capacitors were recharged, hold-up time will be much greater (Figure 12.3, T3 to T5) than if the AC line fails just prior to another recharge (Figure 12.3, T4 to T5).

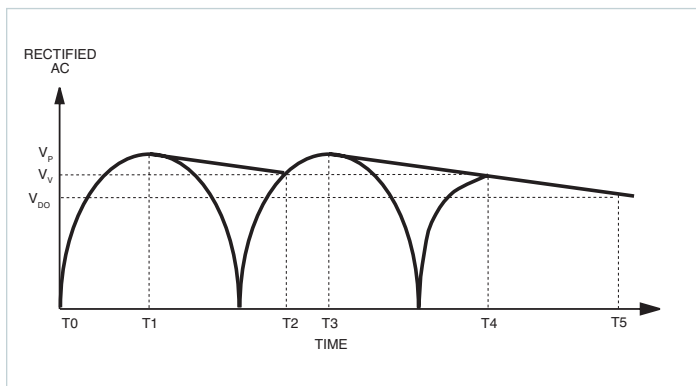

Figure 12.3 — AC waveforms

The basic equations involved in calculating hold-up time are:

$$\frac{1}{2} \cdot C1 \cdot V_P^2 - \frac{1}{2} \cdot C1 \cdot V_{DO}^2 = P_{IM} \cdot (T5 - T3) \quad (1)$$

solving for C1:

$$C1 = 2 \cdot \frac{P_{IM} \cdot (T5 - T3)}{V_P^2 - V_{DO}^2} \quad (2)$$

Where PIM is power delivered from the AIM:

$$P_{IM} = \frac{\text{Module Output Power}}{\text{Module Efficiency}} = \frac{P_{OM}}{\text{Eff. \%} / 100} \quad (3)$$

The energy (Joules) delivered from the AIM from the time power is lost (T4), until loss of an output (Figure 12.2, T5):

$$\text{Energy (joules)} = P_{IM} \cdot (T5 - T4) \text{ (watt-seconds)} \quad (4)$$

Where:

P_{OM} = Output power from all the modules

P_{IM} = Input power to the modules
(output power from the AIM)

Eff = Weighted average efficiency of all modules

The input power to the converter(s) during normal operation is supplied from the AC line during the conduction time of the rectifiers (T2 to T3) internal to the AIM and by the energy stored in C1 when the rectifiers in the AIM are reverse biased (T1 to T2). In the event of an AC failure (T4), C1 must continue to provide energy to the converters until either AC returns or the converter drops out (T5).

The energy stored in C1 at the peak of the AC is:

$$\frac{1}{2} \cdot C1 \cdot V_P^2 = \text{joules} \quad (5)$$

The energy stored in C1 when the converter drops out of regulation is:

$$\frac{1}{2} \cdot C1 \cdot V_{DO}^2 = \text{joules} \quad (6)$$

The energy delivered by C1 to the converters during normal operation is:

$$P_{IM} \cdot (T2 - T1) = \text{joules} \quad (7)$$

Choosing Appropriate Values for AIM Modules

Sample calculation:

- Converter output power (P_{OM}) = 100W
- Line frequency = 60Hz
- Line range = 105 – 264V_{AC}
- Efficiency = 82%
- Desired hold-up time = 5ms (minimum)

Therefore:

$$P_{IM} = \frac{100}{0.82} = 122W$$

$$T5 - T3 = 5ms + 8.3ms = 13.3ms$$

(minimum hold-up time plus half cycle)

$$V_p = 105 \cdot \sqrt{2} = 148V$$

$$V_{DO} = 100V$$

and:

$$C1 = \frac{2 \cdot 122 \cdot 0.0133}{148^2 - 100^2}$$

$$C1 = 270\mu F$$

Where:

V_p = The peak of the rectified AC line or $2 \cdot V_{AC_IN}$. For an input range of 85 – 264V_{AC}, this voltage will vary from 120 to 373V.

V_v = The low point of the rectified AC line under normal operating conditions. This “valley” voltage is a function of C1, P_{IM} and line frequency. The peak-to-peak ripple across C1 is $V_p - V_v$ and determines the ripple current in C1.

NOTE: It is important to verify the RMS ripple current in C1 with a current probe.

V_{DO} = Voltage at which the DC-DC converter(s) begin(s) to drop out of regulation. This voltage is from the data sheet of the appropriate module, which for the VI-270 Family is 100V_{DC}. Under normal operating conditions, V_v must exceed V_{DO} .

T1 = The peak of the rectified AC line or the point at which C1 is fully charged. For an input range of 85 – 264V_{AC}, this voltage will vary from 120 to 373V.

T2 = The low point of the rectified AC line under normal operating conditions and the point at which C1 is about to be “recharged”. This is the point of lowest energy in C1.

T4 = The low point of the rectified AC line; the point of lowest energy in C1; the point at which if the AC line fails, hold-up time is shortest, i.e., “worst case”.

T5 = The time at which the converter(s) drop out of regulation.

T5 – T4 = Minimum hold-up time. Actual hold-up time may vary up to a maximum of T5 – T3.

(T3 – T1) • 2 = One line cycle.

The following values are calculated in a similar manner.

Module(s) Delivered Power	60Hz		50Hz	
	90V _{AC}	105V _{AC}	90V _{AC}	105V _{AC}
50W	270μF	135μF	300μF	150μF
75W	400μF	200μF	440μF	230μF
100W	525μF	270μF	600μF	300μF
150W	800μF	400μF	890μF	455μF
200W	1,000μF	540μF	1,180μF	600μF

Table 12.1 — Hold-up capacitor values for use with VI-270/VI-J70 and the VI-250/VI-J50 DC-DC converters

C1 values as a function of line voltage, frequency and delivered power, for use with the “7” input designator DC-DC converters (AIM input of 90 – 264V_{AC}) or “5” input designator (AIM input of 90 – 132V_{AC}) DC-DC converters.

NOTE: With “7” input DC-DC converters operated from the AIM input range of 90 – 264V_{AC}, 400V capacitors must be used. With “5” input DC-DC converters used over the AIM input range of 90 – 132V_{AC}, 200V capacitors may be used.

Module(s) Delivered Power	60Hz		50Hz	
	180V _{AC}	210V _{AC}	180V _{AC}	210V _{AC}
50W	66μF	34μF	74μF	38μF
75W	100μF	50μF	110μF	60μF
100W	130μF	67μF	150μF	75μF
150W	200μF	100μF	220μF	115μF
200W	262μF	135μF	300μF	150μF

Table 12.2 — Hold-up capacitor values for use with VI-260/VI-J60 DC-DC converters

C1 values as a function of line voltage, frequency and delivered power, for use with the “6” input designator DC-DC converters (AIM input of 180 – 264V_{AC}).

NOTE: With “6” input DC-DC converters operated from the AIM input range of 180 – 264V_{AC}, 400V capacitors must be used (Vicor Part #30240).

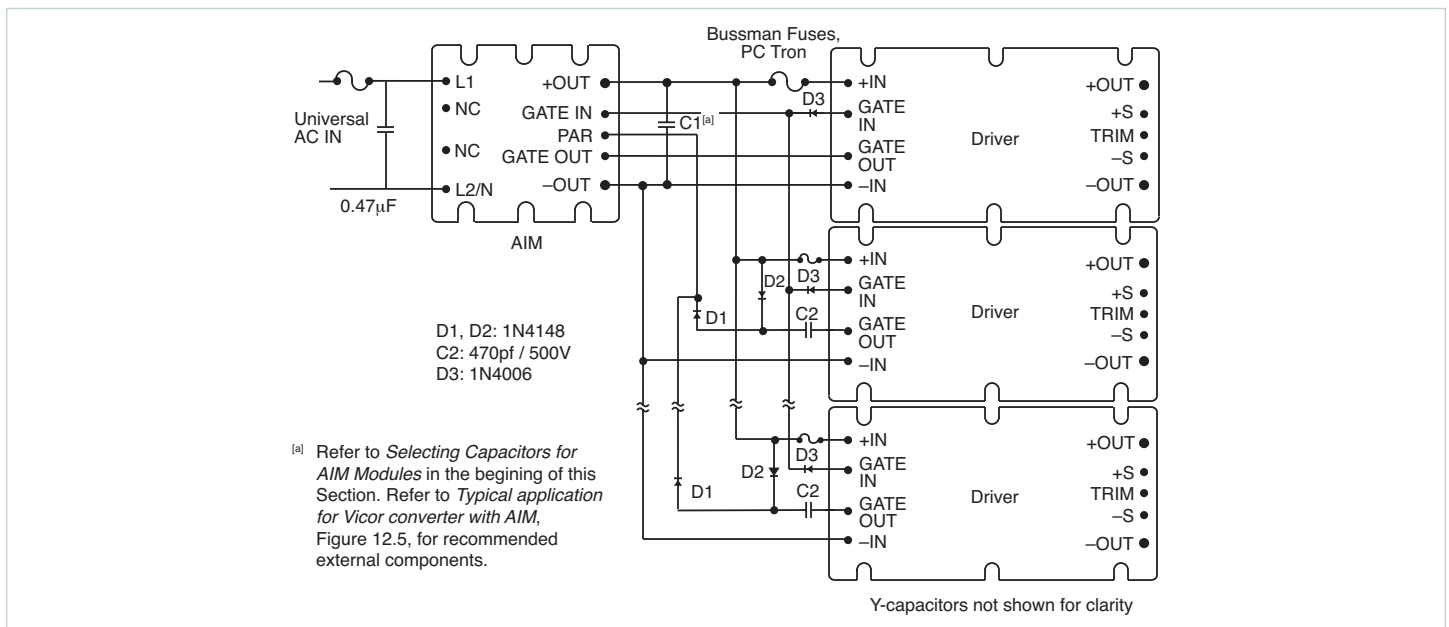

Figure 12.4 — AIM connection diagram, multiple-driver DC-DC converters

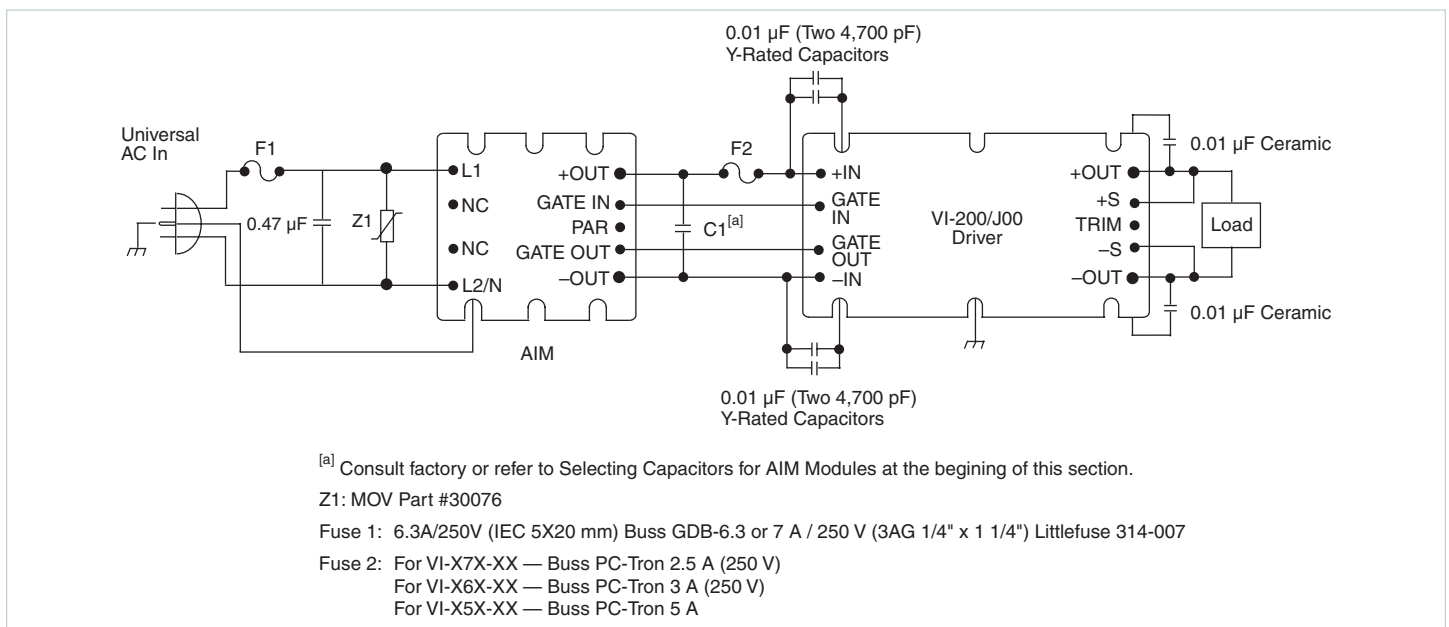

Figure 12.5 — Typical application for Vicor converter with AIM

**The Harmonic Attenuator Module
Compatible with VI-26x and VI-J6x Families**

The Harmonic Attenuation Module (HAM) consists of a full-wave rectifier, a high-frequency zero-current-switching (ZCS) boost converter, active inrush current limiting, short-circuit protection, control, and housekeeping circuitry (Figure 13.1). The incoming AC line is rectified and fed to the boost converter. The control circuitry varies the operating frequency of the boost converter to regulate and maintain the output voltage of the HAM above the peak of the incoming line, while forcing the input current to follow the waveshape and phase of the line voltage. A power factor better than 0.99 is achieved (Figure 13.2). Operating efficiency of the boost converter is optimized at any incoming line voltage by an adaptive output voltage control scheme.

The output voltage of the HAM varies as a function of incoming AC line voltage (Figure 13.3). On a nominal 120V_{AC} line the output voltage of the HAM is 260V_{DC} — well within the input operating voltage range of Vicor VI-26x and VI-J6x converters. As input line increases, so does the HAM output voltage; at 220V_{AC} the delivered voltage will be about 350V. For any given input line voltage, the HAM maintains enough headroom between the output voltage and peak input voltage to ensure high quality active power factor correction without unnecessarily sacrificing operating efficiency.

The HAMD version does not contain an internal bridge rectifier and is intended for configuring higher power arrays with Booster versions, referred to as the VI-BAMD (Figure 13.5).

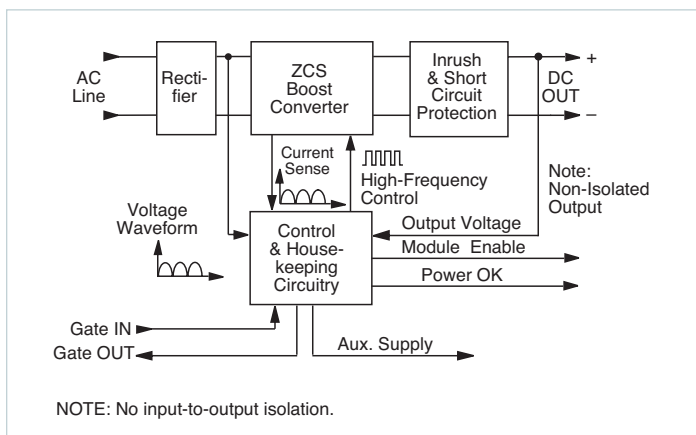

Figure 13.1 — HAM block diagram (HAMD version has the rectifier block deleted)

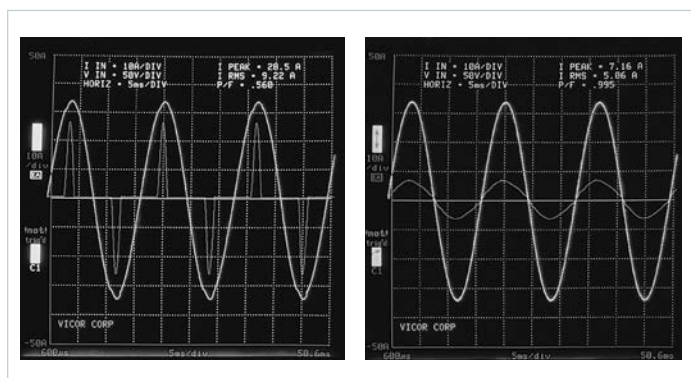

Figure 13.2 — Input voltage and current wave forms, without and with power factor correction

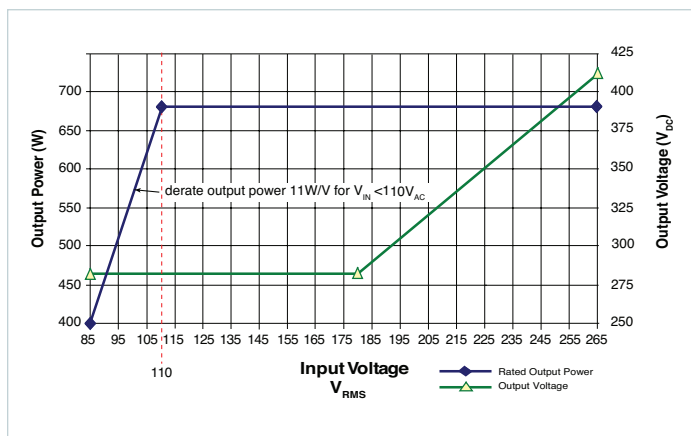

Figure 13.3 — Output voltage and power rating vs. input voltage

L1 and L2/N (HAM) Pin: An appropriate line filter is required to limit conducted emissions and ensure reliable operation of the HAM, see page 40. Connect single phase AC mains to the input of the line filter via a 10A, 250V fuse. Connect the output of the filter to L1 and L2/N of the HAM. Do not put an X-capacitor across the input of the HAM or use a line filter with an X-capacitor on its output as power factor correction may be impacted.

+IN, -IN (HAMD, BAMD) Pin: These pins are connected to the output of the external bridge rectifier in HAMD / BAMD configurations (Figure 13.5).

GATE IN (HAM) Pin: The user should not make any connection to this pin.

GATE IN (HAMD) Pin: This pin provides line voltage envelope and phase information for power factor correction. This connection must be made through the synchronization diodes between the line filter and bridge rectifier (Figure 13.5).

GATE IN (BAMD) Pin: The GATE IN pin is an interface pin to the GATE OUT pin of a HAMD or BAMD depending on configuration. The user should not make any other connection to this pin.

GATE OUT Pin: The GATE OUT pin is a synchronization pin for HAMD/BAMD arrays; the user should not make any other connection to this pin.

+OUT and –OUT Pin: Connect the +OUT of the HAM to the +IN of the respective Vicor DC-DC converters with the recommended fuse. Connect the –OUT of the HAM to the –IN of the converters. In addition, an external hold-up capacitor of 1,000 μ F with a minimum voltage rating of 450V_{DC}, is required (across the output of the HAM) for 16ms ride through time at full power (500 μ F for half power, etc). This capacitor must be in close proximity to the HAM. Do not exceed 3,000 μ F of total output capacitance. Lower values of capacitance may be used for reduced hold up requirements, but not less than 500 μ F. Lower capacitance values may degrade power factor specifications.

Auxiliary Supply (A/S) Pin: The HAM provides a low voltage non isolated output Auxiliary Supply (A/S) that may be used to power primary side control and monitoring circuitry. This output is 19 – 23V_{DC}, referenced to –OUT, at 3mA max. Do not overload or short this output as the HAM will fail. A typical use for A/S is to power an optical coupler that isolates the Power OK signal (Figure 13.6).

Enable Output (E/O) Pin: The Enable Output (E/O) is used to inhibit the DC-DC converters at start up until the hold up capacitors are charged, at which time Enable is asserted high (open state, Figure 13.8). If the AC line fails, E/O goes low when the DC output of the HAM drops below 195V_{DC}.

E/O must be connected to the Gate Input of all VI-26x and VI-J6x drivers (Figure 13.4); failure to do so may cause the converters to toggle on and off. It is not necessary to connect this pin to boosters as they are controlled by their respective driver. If an external load is connected directly to the output of the HAM, do not apply the load until the output hold up capacitor(s) are fully charged.

The E/O pin ancillary circuitry illustrated in Figures 13.4 and 13.5 provides transient immunity. The illustrated circuitry is the minimum required, see Figures 13.4 and 13.5.

Power OK (P/OK) Pin: Power OK is a monitor signal that indicates the status of the AC mains and the DC output voltage of the HAM. P/OK is asserted (active low) when the output bus voltage is within normal operating range 20 – 25ms after DC-DC converters are enabled by the E/O signal of the HAM. This provides sufficient time for the converters to turn on and their output(s) to stabilize prior to P/OK being asserted (Figure 13.9). For momentary interruptions of AC power, the HAM will provide at least 16ms of ride through or hold up time (with 1,000 μ F output capacitor). On loss of power or brownout, (when the HAM output voltage drops below 230V_{DC}) the P/OK signal will go to an open circuit state (see Figure 13.7), signaling an impending loss of input power to the converter modules. P/OK will provide power fail warning at least 1ms prior to converter shut down. When the HAM output voltage drops below 195 V_{DC} the converters are disabled via Enable Output (E/O).

NOTE: Acoustic Noise. Audible noise may be emitted from the module under no-load, light-load, or dynamic-loading conditions. This is considered normal operation of the module.

Safety Notes

Each HAM, HAMD or BAMD module must be preceded by a safety agency recognized fast-blow 10A 3AG fuse.

The HAM is not isolated from the line – either input or output; a line isolation transformer must be used when making scope measurements. HAMs do not provide input to output isolation. Differential probes should be used when probing the input and output simultaneously to avoid destructive ground loops.

Protective Features

Overtemperature Shut Down: The HAM is designed to shut down when the temperature of the baseplate exceeds 90°C. Do not operate the HAM above its maximum operating temperature of 85°C.

Short Circuit Protection: The HAM contains output short circuit protection. Operation of this function does not clear the input fuse and the output will resume normal operation after removal of the fault.

A short period of time may be required to allow for cooling of an internal temperature sensor.

Output Overvoltage Protection: The HAM contains output over voltage protection. In the event the output voltage exceeds approximately 420V_{DC}, the boost will decrease to maintain 420V_{DC} on the output. When the peak of the AC line exceeds 420V (approximately 293V_{AC}) the boost will have been reduced to zero and the E/O line will be pulled low shutting down the converters. Beyond this the protection circuit will be enabled and the output voltage will decrease.

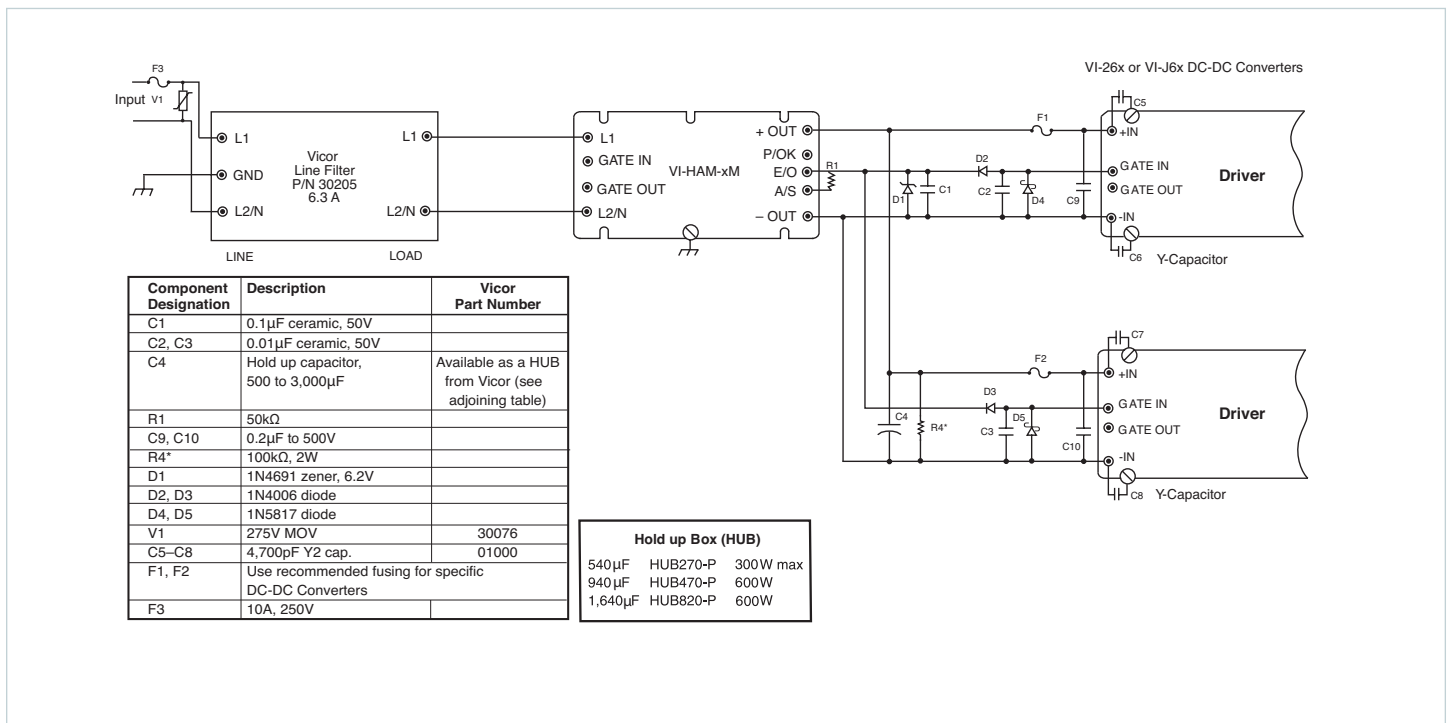

Figure 13.4 — Connection diagram HAM / DC-DC converter

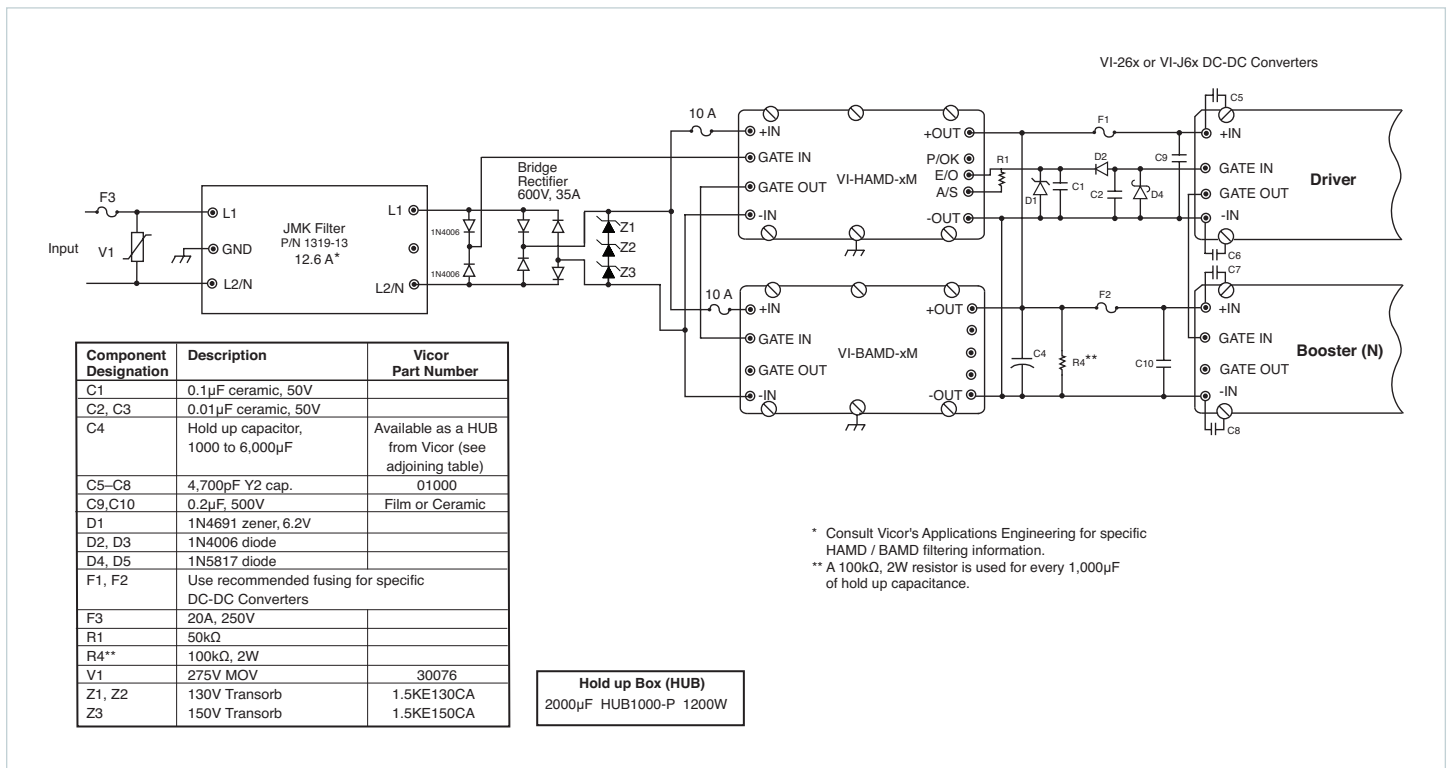

Figure 13.5 — Connection Diagram, HAMD / BAMD / VI-26x or VI-J6x DC-DC Converters
 HAMD-CM Driver HAM: no internal bridge rectifier or synchronization diodes;
 BAMD-CM Booster HAM: companion module to HAMD-CM used for additional output power; no internal bridge rectifier

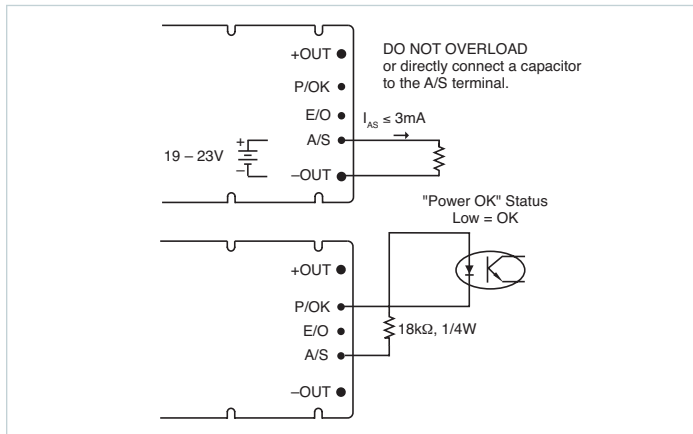

Figure 13.6 — Auxiliary Supply (A/S)

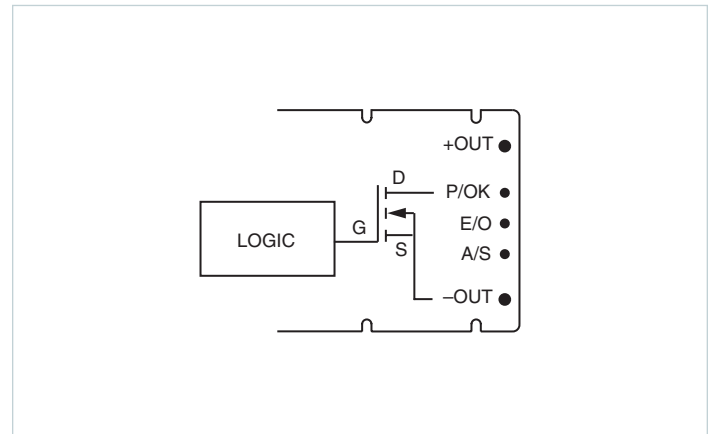

Figure 13.7 — Power OK (P/OK)

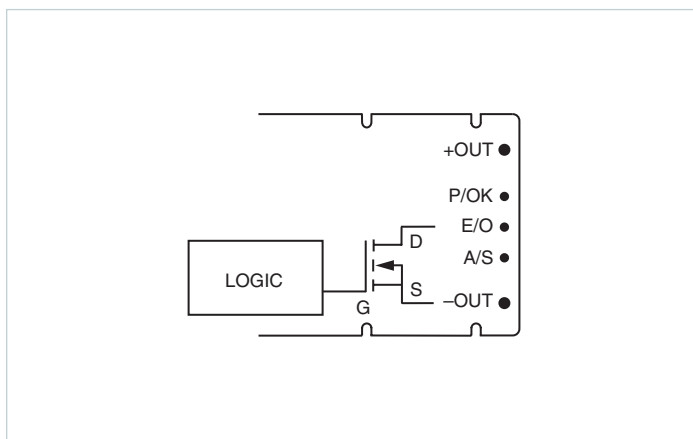

Figure 13.8 — Enable Output (E/O)

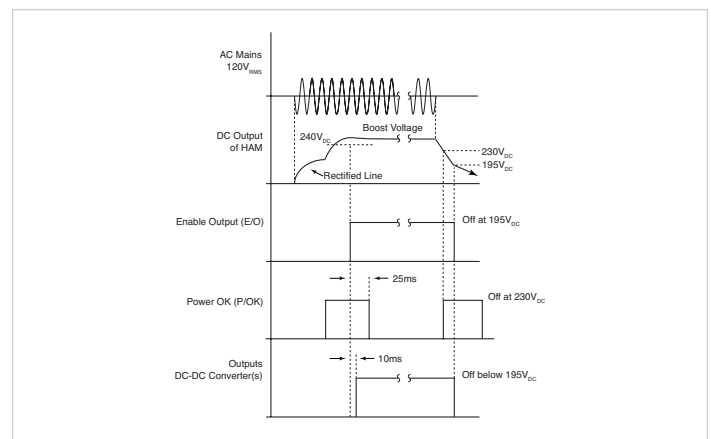

Figure 13.9 — Start-up / shut-down timing diagram

Line Filter for High-Boost HAM

A line filter is required to provide attenuation of conducted emissions generated by the HAM module and to protect it from line transients. It also presents a well defined high frequency AC line impedance to the input of the HAM. To meet the listed specifications, Vicor P/N 30205 line filter/transient suppressor or equivalent must be used (Figure 13.10). The addition of a MOV external to this filter is required to meet normal mode transient surge requirements.

For applications using HAMD + BAMD or where the user desires to construct a custom HAM filter, the filter should be designed following Figure 13.10, the schematic of the Vicor P/N 30205 filter. The current carrying capability of the inductors must be scaled proportionally to the number of HAM modules used. Inductance values must be selected according to Table 13.1. These limits are to ensure proper operation of the HAM and do not guarantee a system will meet conducted emissions specifications.

For applications requiring magnetic field shielding, do not place a ferrous EMI shield over the plastic cover of the HAM module. This can cause thermal problems due to induction heating effects.

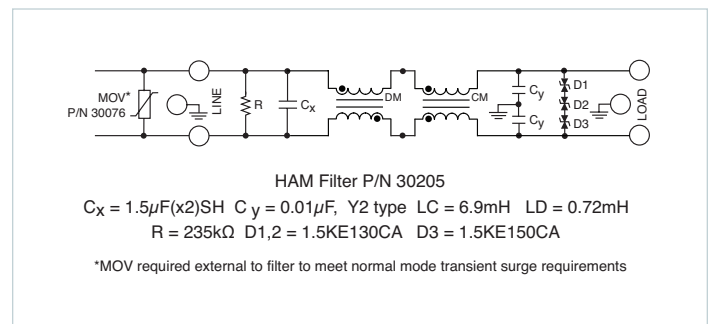

Figure 13.10 — Recommended HAM filter

Parameter	Min	Typ	Max	Unit
Differential Mode Inductance (LD)	0.2	0.35	0.75	mH
Common-Mode Inductance (LC)	3	6		

Table 13.1 — HAM filter inductance range

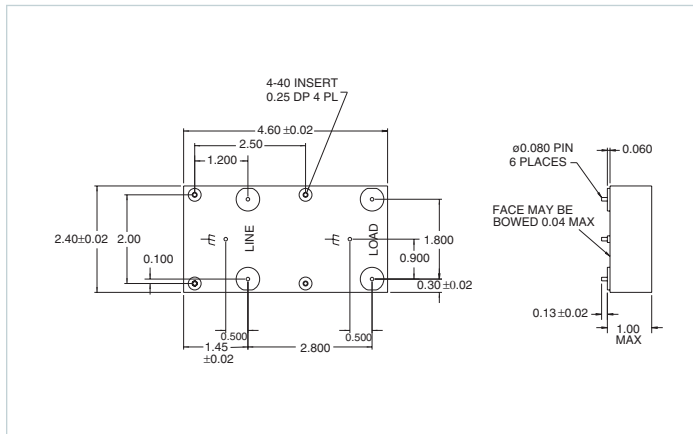

Figure 13.11 — HAM filter mechanical diagram

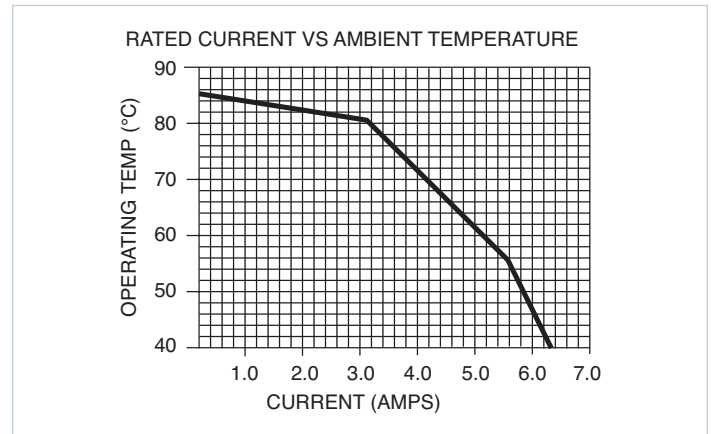

Figure 13.12 — HAM filter's current rating vs. temperature

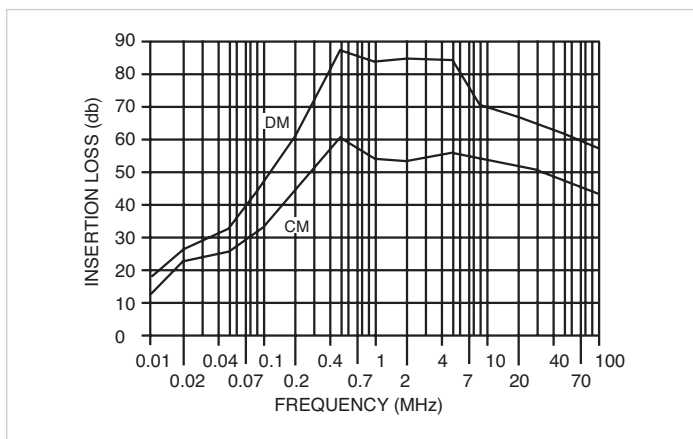

Figure 13.13 — HAM filter insertion loss vs. frequency

Parameter	Min	Typ	Max	Unit
Operating Voltage	85		250	V _{AC}
Operating Temperature (see Figure 13.12)	-20		50	°C
Leakage Current at 264VAC, 63Hz (Either Line or Earth)			1.2	mA
Operating Current			6.3	A
Dielectric Withstand (Line – Case)			1500	V _{AC}
Residual Voltage after 1s			34	V
Operating Frequency	50		60	Hz

Table 13.2 — HAM filter part #30205 specifications

HAM Dos and Don'ts

The following cautions should be observed before applying power to the HAM.

- It is important that the output of the HAM not be loaded until the input voltage has exceeded $85V_{AC}$ and the output has begun to boost to $260V_{DC}$. This means that if the load on the HAM is a Vicor converter, the Enable Output of the HAM must be connected to the GATE IN of all Driver modules. The HAM will then disable the module output until the input exceeds $85V_{AC}$ and the output has been boosted to $260V_{DC}$. If an external load is connected directly to the output of the HAM, do not apply the load until the output of the HAM is stabilized in boost mode.
- Although the efficiency of the HAM is quite high, it still dissipates significantly more power than a VI-26x DC-DC converter. Care should be taken to cool it. Do not rely on the internal overtemperature shut down to take the place of adequate planning relative to the cooling of the HAM. Thermal compound should be used between the heat sink and baseplate of the HAM, HAMD and BAMD.
- Power factor is 0.997 at $120V_{AC}$ and 0.995 at $240V_{AC}$. Harmonic content at $240V_{AC}$ is therefore somewhat higher than at $120V_{AC}$. Remember that harmonic content measured cannot be any lower than the harmonic content of the AC mains. A precision AC source is required for accurate power factor measurements.
- The input voltage range of the HAM is $85 - 264V_{AC}$; however it may not start boosting until the AC mains has exceeded $87V_{AC}$. Once the HAM has started, it will operate down to $85V_{AC}$. The HAM contains 2.5 – 6V of input hysteresis, therefore if the AC line impedance is high, i.e., when using a variable autotransformer, the HAM may start, but the AC line may then fall enough to drop below undervoltage lockout. When this happens the AC line will go up, the HAM starts and the cycle repeats. Therefore avoid soft AC lines at or near low line.

Overview

The IAM is a component-level, DC input front-end filter that when used in conjunction with the Vx-200 and Vx-J00 Family of DC-DC converters provides a highly efficient, high density power system with outputs from 1 – 95V_{DC} and power expansion from 25 – 800W.

There are five input attenuator modules available for the commercial market that comply with telecommunication and industrial control EMC specifications: Refer to data sheets for applicable standards at vicorpower.com.

Model	Input Voltage Range	Maximum Output Power [a]
VI-A11-xU	24V (21 – 32V)	200W
VI-AWW-xU	24V "W" (18 – 36V)	200W
VI-A33-xQ	48V (42 – 60V)	400W
VI-ANN-xQ	48V "N" (36 – 76V)	400W
VI-A66-xQ	300V (200 – 400V)	400W

Table 14.1 — Output power capability

[a] Based on DC-DC converters with 5V outputs or higher.

There are two input attenuator modules available for the defense market that comply with military EMC specifications, transient specifications and spike specifications. Refer to product data sheet for applicable standards at vicorpower.com.

Model	Input Voltage Range	Maximum Output Power of Converter Combinations
MI-A22-xU	28V (16 – 50V)	200W
MI-A66-xU	270V (125 – 400V)	200W

Table 14.2 — Output power capability

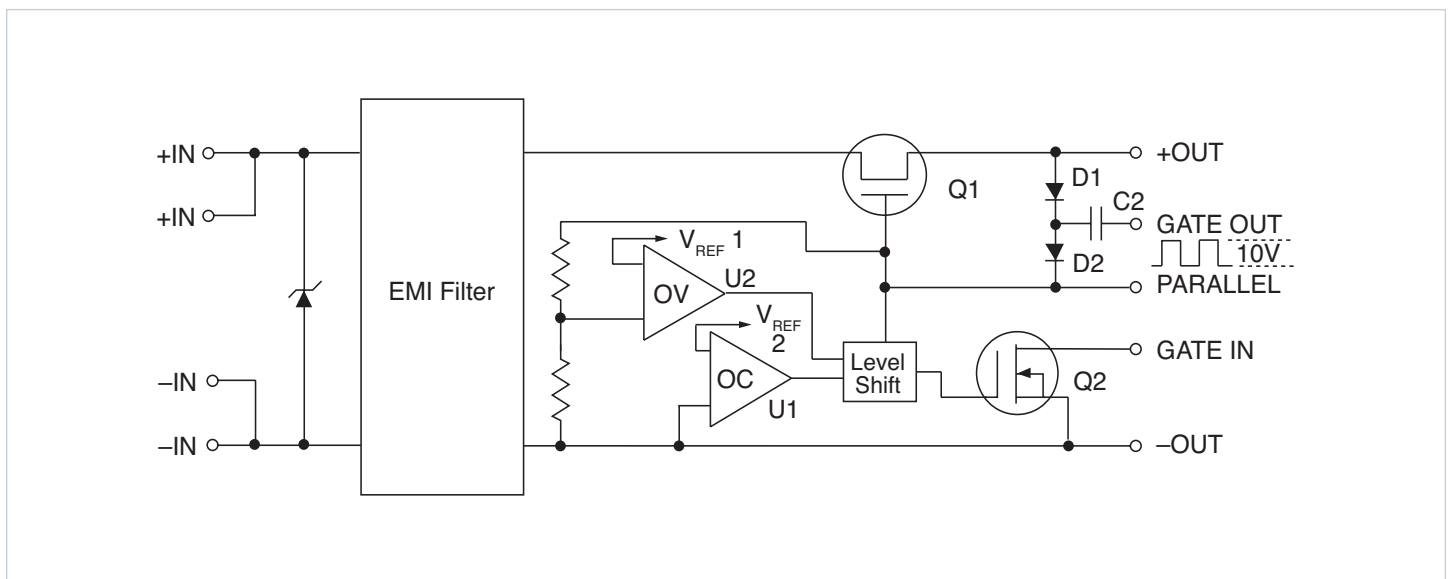

Figure 14.1 — Block diagram of Input Attenuator Module (IAM)

EMC

EMC performance is guaranteed when the IAM is used in conjunction with the recommended Vicor converters within the permissible power rating and in accordance with the recommended installation procedure. (Figure 14.3) The capacitor shown across the input of the converter and bypass capacitors shown on the –IN and +IN of the DC-DC converters to ground are required to meet EMC specifications. The capacitors should be Y-rated (interference suppression). Y capacitors have high voltage breakdown ratings to meet the isolation characteristics of the module’s input to baseplate specification, self-healing properties, and safety agency approvals.

Input Reverse Polarity Protection

A Zener diode in the EMC filter provides reverse polarity protection when used with a properly rated fuse external to the IAM. The characteristics of the recommended input line fuses permit normal full load operation with protection in the event of a reverse polarity by clearing of the fuse. (Table 4.3).

Input Transient Protection

A Zener diode, inductor and capacitor in the EMC filter protect against short term transients. Transient voltages that persist beyond these limits are dropped across an N-channel enhancement FET, Q1. It is necessary that the FET be kept in saturation mode during normal operation. Thus it is necessary to connect the DC-DC converters’ GATE OUT to the IAM’s GATE OUT to charge pump the

gate of the FET to a voltage in excess of its source. In the case where multiple DC-DC Driver modules are connected to one IAM, an external charge pump through the parallel pin (connected to the gate of the FET) must be added to ensure that the FET remains enhanced in the event GATE OUT enhancement is lost (Figure 14.4). The additional circuitry, C2, D1 and D2 are added externally to charge pump through the parallel pin.

Shut down of the DC-DC converters is accomplished by saturating Q2 during an input overvoltage to prevent possible damage to the converters. The IAM will automatically restart when the input overvoltage is reduced to within the input voltage range.

If the long term transient withstand specifications are exceeded, the recommended external fuse will clear.

Input Voltage	Recommended Fuse
24V	20A / 32V (AGC-20)
24V "W"	20A / 36V (AGC-20)
48V	20A / 60V (3AB-20)
48V "N"	20A / 80V (3AB-20)
300V	5A / 250V Bussman PC-Tron
28V	20A / 250V (3AB-20 or F03A, 125V, 20A)
270V	5A / 250V Bussman PC-Tron or F03A, 250V, 4A

Table 14.3 — Recommended fusing based on input voltage

Input Current

Inrush current is a function of the number of DC-DC converters that are connected to the input attenuator module (modules are not gated off at turn-on) and the amount of external capacitance added between the Input Attenuator Module and the DC-DC converter. The inrush current specification is 125% of steady state input current for 10ms. To avoid excessive dissipation in the element controlling the inrush (Q1), the following maximum values of external capacitance must be adhered to.

Input Voltage	Maximum Capacitance [a]
24V _{DC} (21 – 32V)	470µF
24V _{DC} (18 – 36V)	470µF
28V _{DC} (18 – 50V)	390µF
48V _{DC} (42 – 60V)	220µF
48V _{DC} (36 – 76V)	120µF
270V _{DC} (125 – 400V)	27µF
300V _{DC} (200 – 400V)	27µF

Table 14.4 — Recommended distributed capacitance on input of DC-DC converter(s)

Safe Operating Area

(1% duty cycle max., Z_S = 0.5Ω, for short duration transient capability refer to specifications).

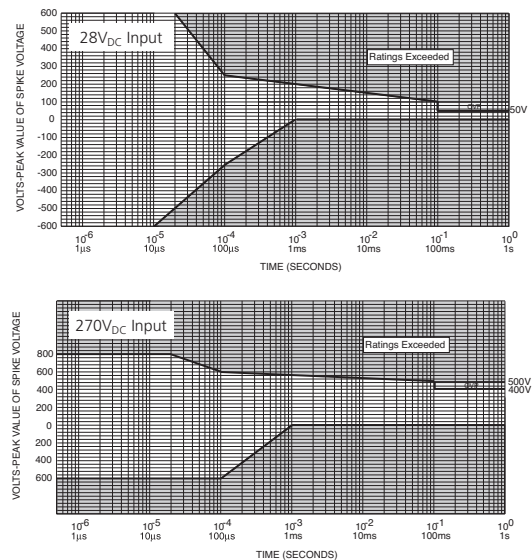
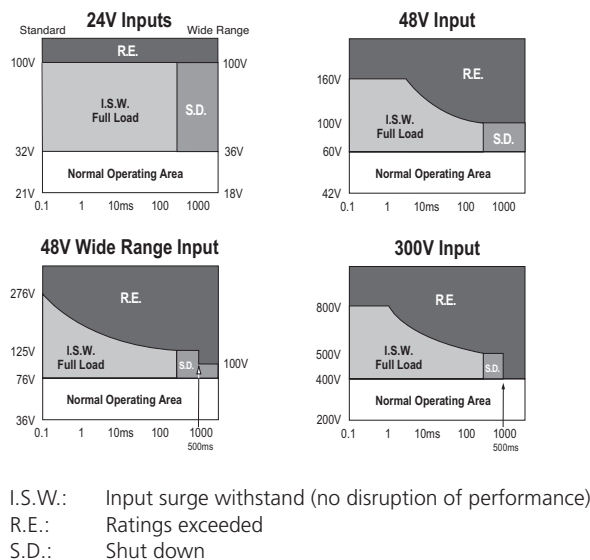

Figure 14.2 — Output noise, with Ripple Attenuator Module (RAM)

Output Overcurrent / Short Circuit Protection

Output overcurrent protection is a foldback type, followed by a timed latched shut down should the overcurrent persist beyond 2ms. If the overcurrent condition is removed before the timeout interval, auto restart shall occur. Should latched shut down occur, input power must be recycled to restart.

Output Overcurrent Threshold	
24V _{IN} "W," 28V _{IN} , 48V _{IN} "N"	20A
24V _{IN} , 48V _{IN}	15A
270V _{IN} , 300V _{IN}	4A

Table 14.5 — IAM overcurrent

Expansion Capabilities

The Input Attenuator Module incorporates a parallel pin permitting power expansion as long as the total output power from the DC-DC converters does not exceed the power rating of each Input Attenuator Module (EMC specifications are guaranteed for up to two input attenuators in parallel). It is necessary to include a 100Ω, 1/4W resistor between the negative outputs of the Input Attenuator Modules to ensure equal potential at these points when paralleling Input Attenuator Modules, so as not to impact the effectiveness of the internal common-mode choke.

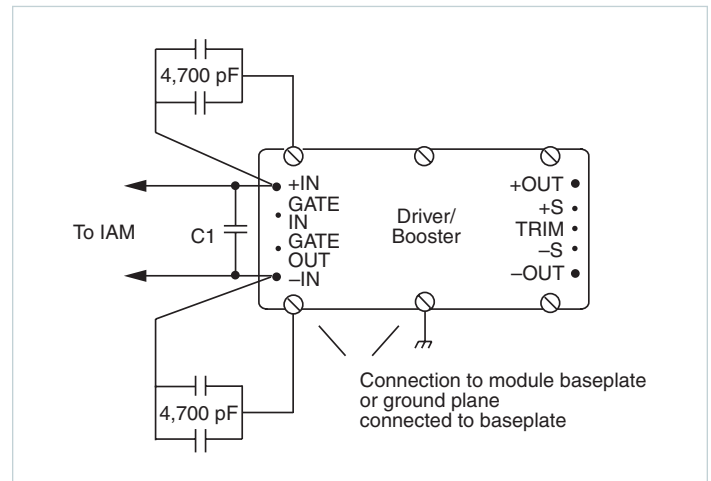

Figure 14.3 — External x, y capacitors for EMC requirements

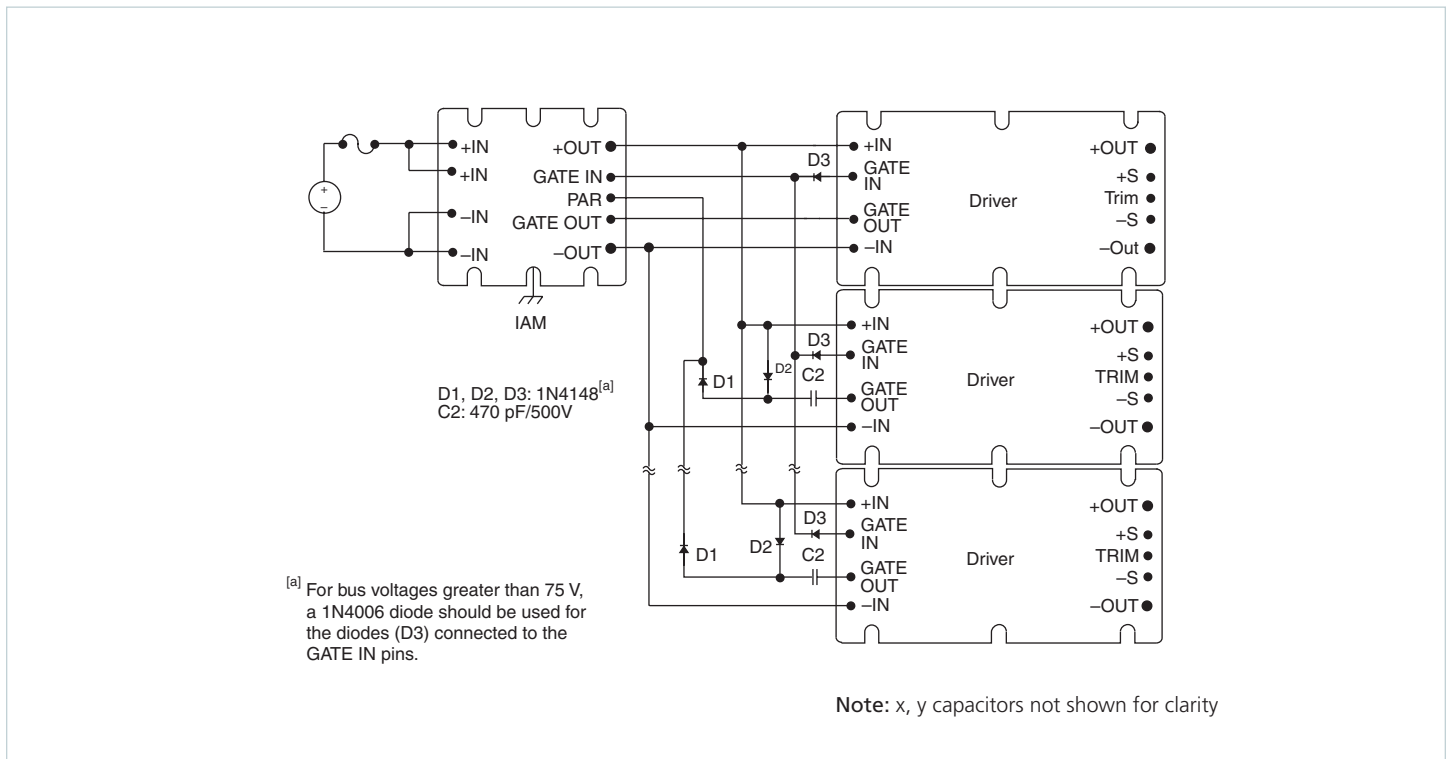

Figure 14.4 — IAM multiple-driver interconnection

Safety Considerations

Shock Hazard. Agency compliance requires that the baseplate be grounded or made inaccessible

Fusing. Safety agency conditions of acceptability require module input fusing. See [Table 14.3](#) for recommended fuse ratings.

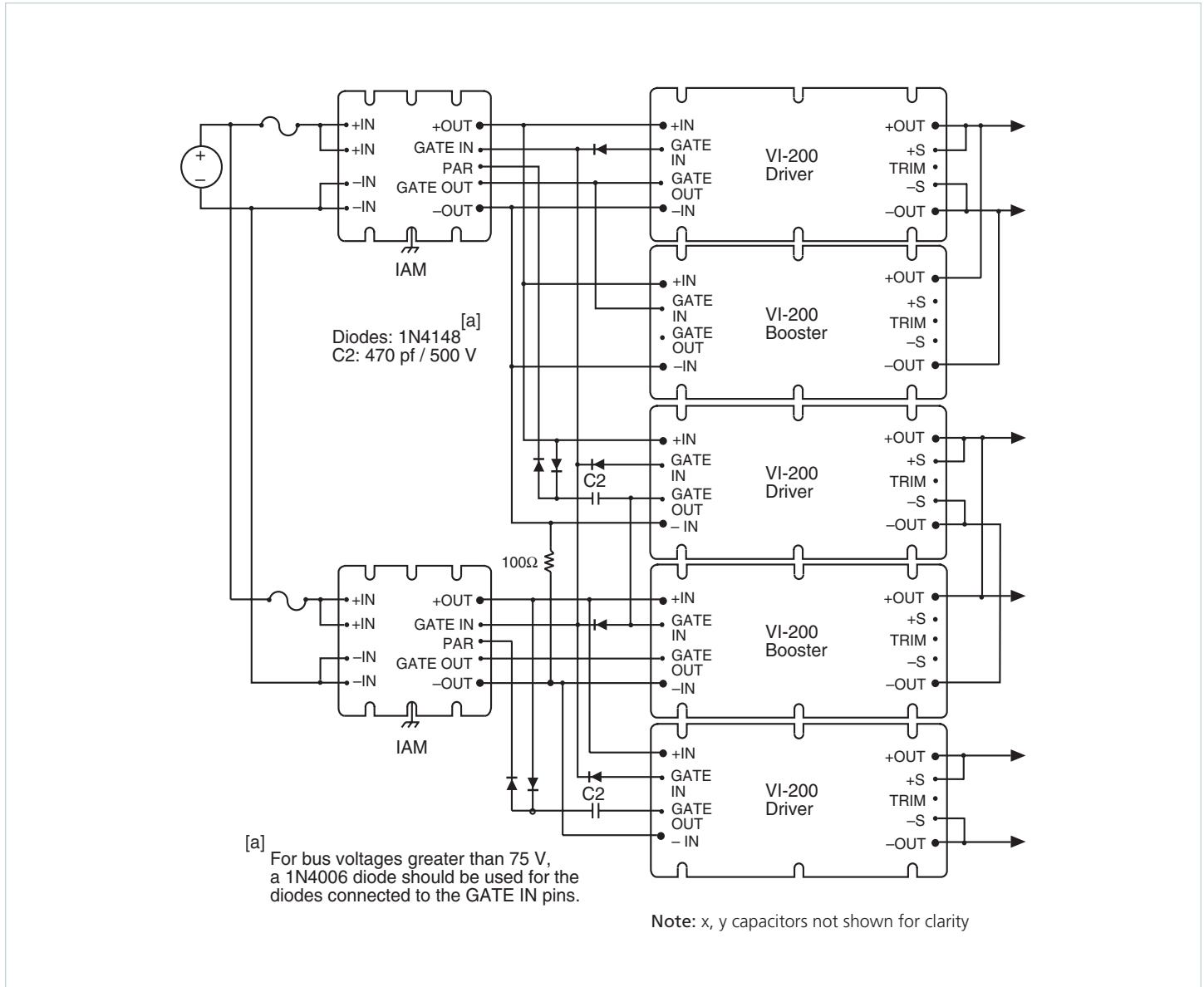

Figure 14.5 — Paralleling connections for the IAM

Overview

The RAM/MI-RAM is an accessory product for VI-/MI-200, VI-/MI-J00, MegaMod/MI-MegaMod, CompPAC/MI-CompPAC and FlatPAC. It reduces line frequency related ripple and converter switching noise to less than 3mV_{p-p} (10mV_{p-p} on the VI-J00).

Features include:

- Reduced differential noise (<3mV_{p-p} at loads up to 20A). The input of the RAM must be between 5 – 50V_{DC}.
- Active and passive filtering
- Attenuation of low frequency input power source harmonics and high frequency switching components from DC-20MHz
- Remote sense, trim, overvoltage protection and overcurrent protection features retained

Applications for the RAM include medical diagnostic and automated test equipment, radio receivers, transmitters and communication products, and other products requiring the noise performance of a linear supply. Refer to [RAM operation](#) in Section 9.

The RAM is a combination active / passive filter. A simplified schematic is shown in Figure 15.2. The output of the switcher feeds directly into a high frequency passive filter which attenuates the switching noise. Low frequency, line related ripple attenuation is via a FET series regulator that maintains a constant average forward voltage drop of about 350mV. The FET gate is modulated to maintain the AC component of the FET drain-source voltage equal to the ripple component of the incoming DC voltage, effectively cancelling it out.

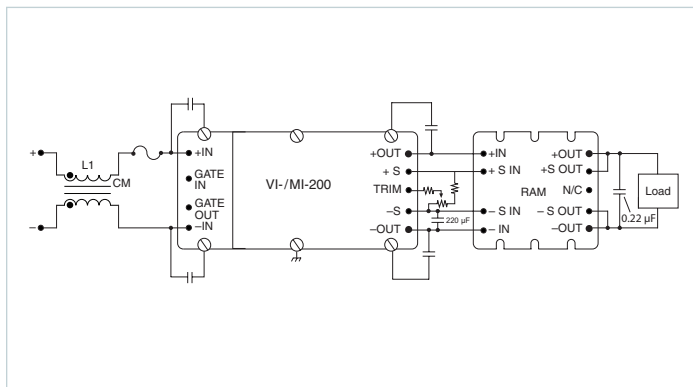

Figure 15.1 — RAM with optional trimming circuit and recommended common-mode choke

The power supply’s sense leads feed through the RAM for connection at the RAM output, for local sense, or at the load, for remote sense (converter compensation is 0.5V maximum). The attenuation and insertion loss are constant up to 10A or 20A, depending on model. In overload (above 10A or 20A), the voltage drop will increase as the current increases. A single RAM can be used on any output from 5 – 50V_{DC} and will maintain the original output set point of the converter within 0.5% at the sense connection. Care should be taken not to connect IN to OUT pins (i.e., through scope probe returns, grounds, etc.) as attenuation will be adversely affected.

Inserting the RAM into the output leads of a Vicor VI-200/VI-J00 converter adds phase shift to the converter’s control loop. This occurs because voltage is sensed at the output of the RAM’s internal filter. The 220µF capacitor between –S IN and –IN (See Figure 15.1) provides additional high-frequency bypassing for the sense leads to ensure stability of the converter and RAM. It may be possible to reduce its value or remove it in applications where transient response is important. If it is removed a network analyzer should be used to verify stable operation.

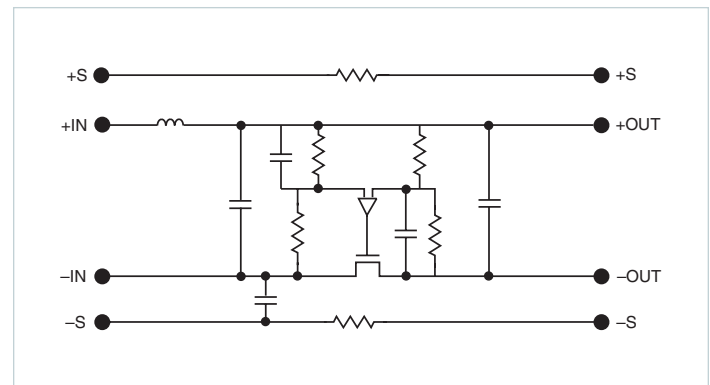

Figure 15.2 — Basic RAM schematic

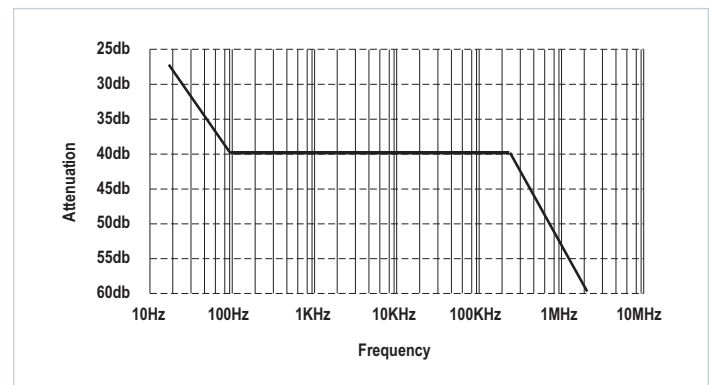

Figure 15.3 — Attenuation vs. frequency (typical)

Single-Phase Front Ends

Vicor’s single phase non-isolated AC front ends are available in both PCB and chassis mount versions, and deliver reliable DC bus voltage to VI-x6x converter modules or Mega Modules at power levels up to 250, 500 and 750W. These front ends are strappable to provide operation from either 115V_{AC} or 230V_{AC} single-phase lines, and provide conducted EMC filtering to VDE / FCC Level B. They also offer transient surge

protection, active inrush limiting, AC-OK (AC fail indicator), and a BUS-OK status output suitable for controlling Vicor modules via the GATE IN pin.

Vicor front ends have been designed to comply with the requirements of major safety agencies when used in conjunction with recommended mains switching and input fusing.

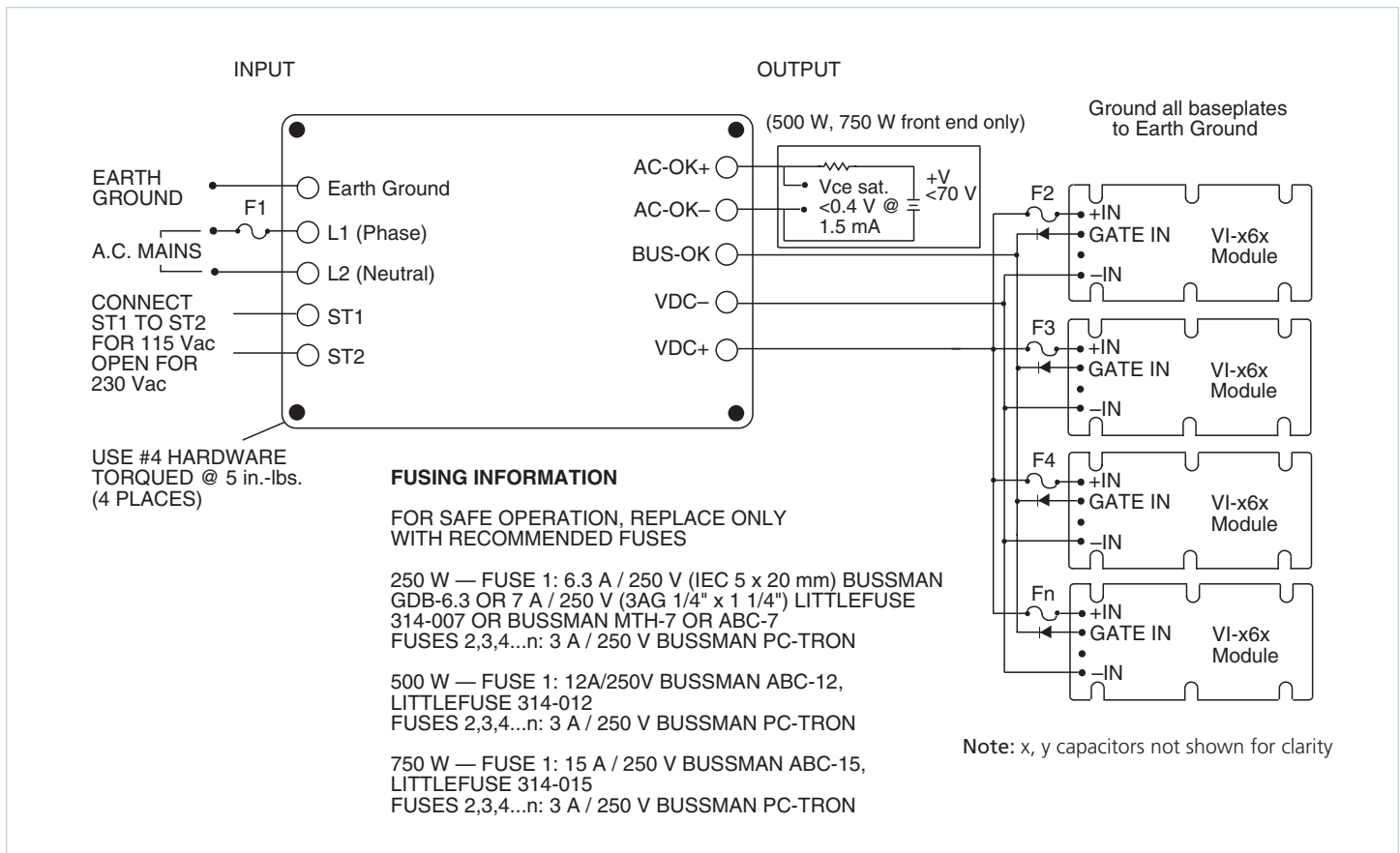

Figure 16.1 — 250W, 500W, 750W front ends

Notes

- Ambient temperature must be less than 50°C in free air. Temperature may exceed 50°C with moving air. (refer to de-rating curves in Figure 16.2)
- Do not obstruct vent holes.
- Observe module installation requirements (refer to [Module Dos & Don'ts](#), Section 3).
- Minimize length of all unshielded line cord.
- Minimum conductor size for supply is 16AWG (250W), 14AWG (500W) and 12AWG (750W) including the 115/230 strap.
- If the DC output bus is shorted before application of AC power, the fuse may not blow, and the unit will not turn on.
- If wire distance from front end to modules is greater than 3 feet, (0.91m) install a TRANSZORB (Part #1.5KE400A) across the input of each module.

- If unit is strapped for 115V operation and 230V is applied, the input fuse will clear. Replace fuse, strap correctly and reapply power.
- To control EMC most effectively, the return path to ground from either the front end or modules should be made via a good RF ground (i.e., a braided wire) if possible.
- The BUS-OK, V_{DC-} and V_{DC+} lines should be run in close proximity to one another or as a twisted group between the front end and modules.
- Bypass the baseplates of the modules to -IN and -OUT (refer to [EMC Considerations](#), Section 9).

Thermal Considerations

Free Convection Derating

- 250W:
Derate output power linearly at 7.2W/°C over 50°C.
- 500W:
Derate output power linearly at 14.3W/°C over 50°C.
- 750W:
Derate output power linearly at 18.8W/°C over 45°C.

Forced Convection. The curves to the right represent worst case data for chassis mounted (enclosed) front ends; i.e., low line, full load. System conditions such as higher line voltage, lighter load or PC mount versions of the front ends will increase reliability if the following data is used as the nominal design criteria.

The sigmoid shape of the curves at low airflow is due to the chassis mount cover restricting the airflow to the inboard components. When an airflow of approximately 200LFM is achieved, the velocity of air rushing over the cover causes air to be pulled in through the side perforations, resulting in a rapid improvement in the cooling of internal components.

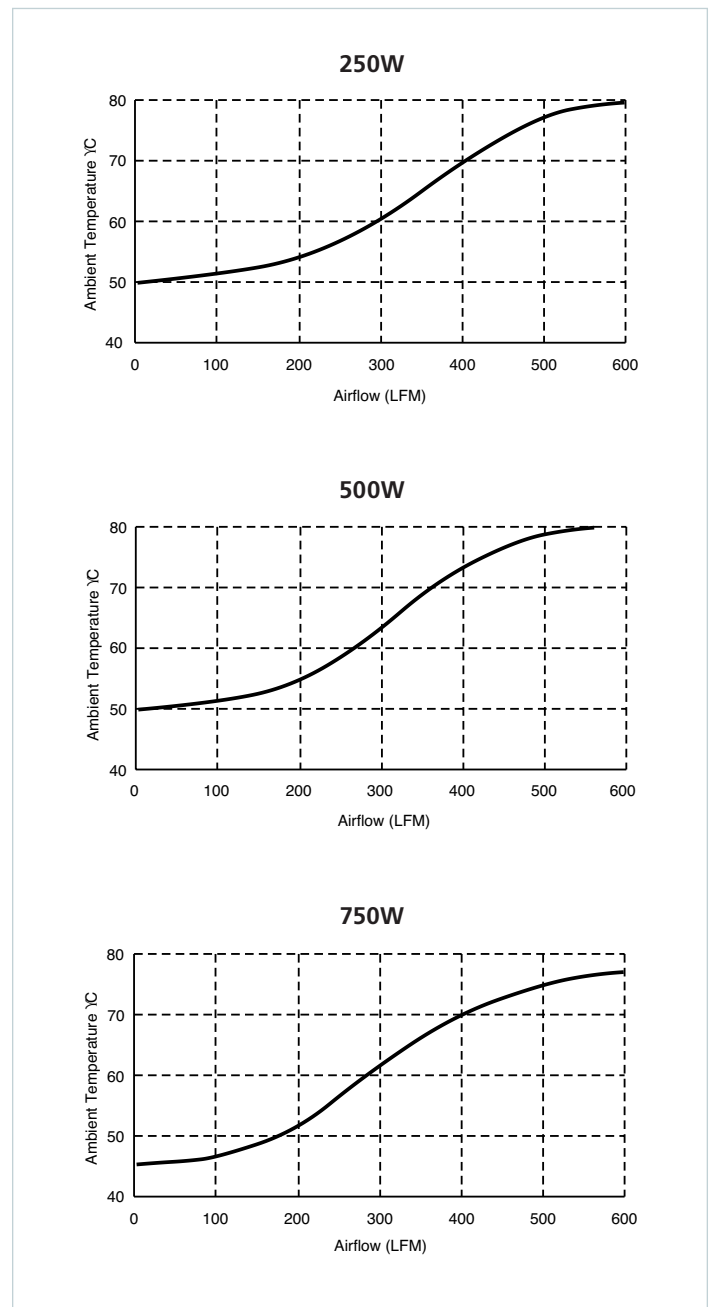

Figure 16.2 — Maximum ambient temperature vs. airflow (LFM) over cover (full load, 90V_{AC} input, chassis mount)

3-Phase Front End

Vicor 3-phase front ends are available as chassis-mount products that deliver reliable DC bus voltage to VI-x6x Family (nominal 300V_{DC} input) converters up to 1.5kW, 3kW and 5kW.

Front ends operate from 3-phase (4-wire delta or 4- or 5-wire wye) AC mains input and provide conducted EMC filtering to VDE/FCC Class A, transient surge protection, inrush current limiting and ENABLE output suitable for controlling an array of Vicor converters via the GATE IN pin. Isolated AC-OK and BUS-OK outputs are

also provided for advance warning of DC bus dropout due to AC line failure and indication of internal DC bus integrity in the user system, respectively.

These front ends have been designed to comply with the requirements of major safety agencies when used in conjunction with the recommended mains switching and input fusing

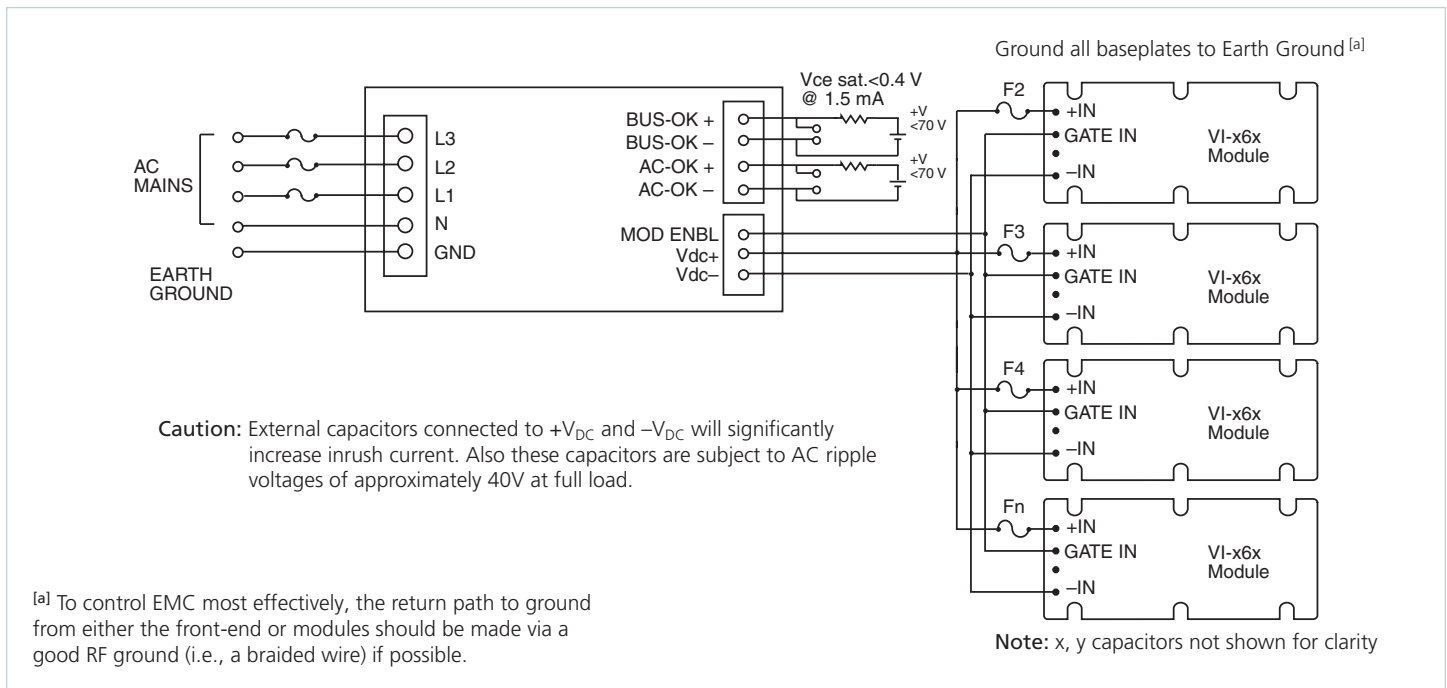

Figure 16.3 — 1.5, 3.0kW front end

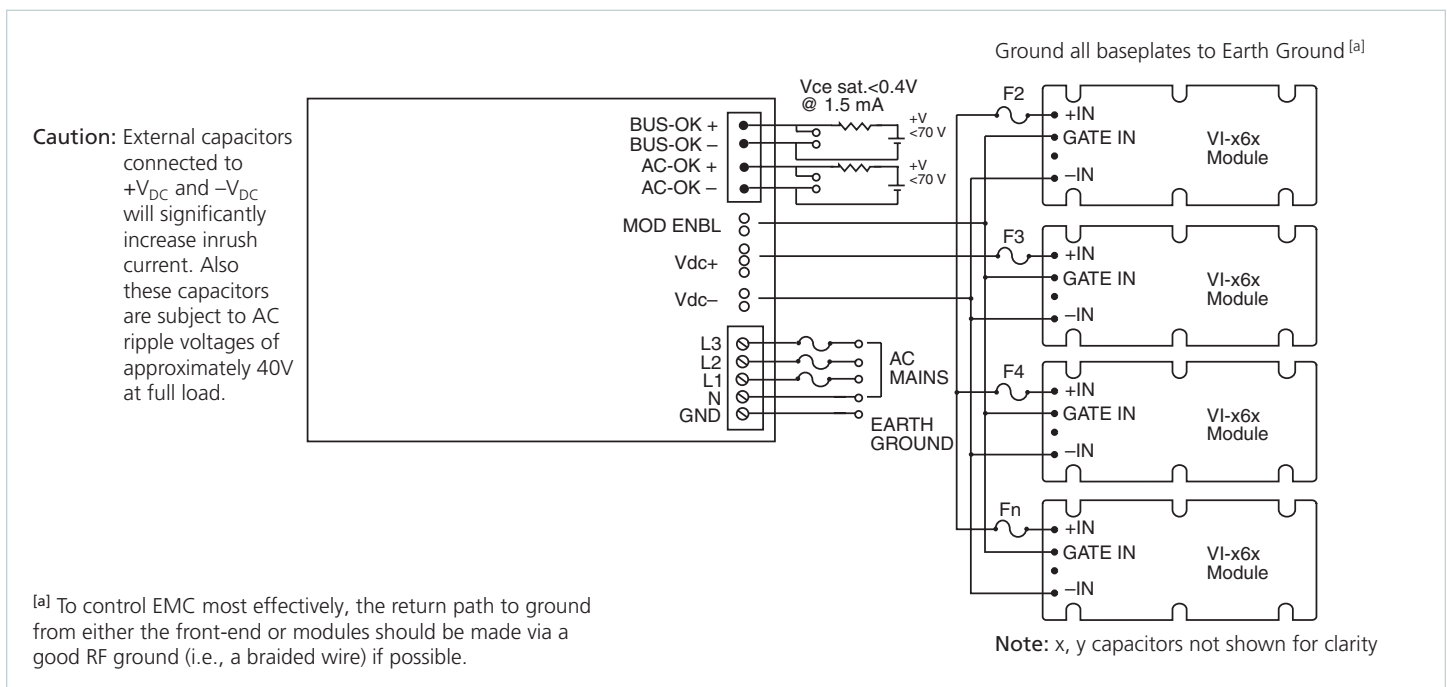

Figure 16.4 — 5.0kW front end

Fusing Information

- 1.5kW front end: 7A / 250V normal blow in all three phases of the AC line (Bussman ABC-7 or Littlefuse 314-007).
- 3kW front end: 12A / 250V normal blow in all three phases of the AC line (Bussman ABC-12 or Littlefuse 314-012).
- 5kW front end: 20A / 250V normal blow in all three phases of the AC line (Bussman ABC-20).

Environmental Data

- Operating temperature (no load to full load): -20°C to $+50^{\circ}\text{C}$, free convection
- Non operating temperature: -40°C to $+80^{\circ}\text{C}$
- Operating / non-operating humidity: 95% relative, non-condensing

Electrical Data — AC Line Input Voltage Connections (phase to phase)

- 3-phase delta (4-wire): $208V_{AC}$ (nominal) $+20\%$ / -10% . Connect the three phases (L1, L2, L3) and GND (earth) to the five-terminal barrier block marked as such.
- 3-phase wye distribution (5-wire): $208V_{AC}$ (nominal) $+20\%$ / -10% . Connect the three phases (L1, L2, L3), N (neutral), and GND (earth) to the five-terminal barrier block marked as such.
- Line frequency: 47 – 440Hz

DC Output Connections and Module Enable

A three terminal barrier block labeled V_{DC-} , V_{DC+} and MOD EN provides both the DC input enable and enable control line for Vicor converters.

- V_{DC-} : Negative DC input terminal to all Vicor converters.
- V_{DC+} : Positive DC input terminal to all Vicor converters.
- MOD EN: Connect to the GATE IN terminal of all Driver modules. This connection must be made to guarantee proper enabling of the converter array on power-up and proper shut down of the converter array on power loss, loss of phase or output fault.

Cautions

This product is designed to operate with Vicor VI-x6x Family ($300V_{DC}$ input) converters, Mega Modules and the $300V_{IN}$ Maxi, Mini and Micro converters.

- This product is not intended for use with European 380 – $415V_{AC}$ three phase distribution.
- This product is an offline AC-DC power supply. It is not isolated from the AC mains.
- Proper grounding is mandatory for safe operation.

Overview

The ComPAC is a low-profile, highly efficient, high-density configurable DC-DC power solution with EMC filtering, transient protection and reverse polarity protection. It has an isolated master disable input for remote shut down, and provides outputs from 1 – 95V_{DC} and power-up to 600W.

There are five input voltages available which comply with telecommunication and industrial control EMC specifications. Refer to data sheet for applicable standards at vicorpower.com.

Nominal Input Voltage	Input Designator	Input Voltage Range
24V	1	21.7 – 32V
24V (wide)	W	18.7 – 36V
48V	3	42 – 60V
48V (wide)	N	36 – 76V
300V	6	200 – 400V

There are two military input voltages available which comply with military EMC specifications and the transient and spike specifications. Refer to data sheet for applicable standards at vicorpower.com.

Nominal Input Voltage	Input Designator	Input Voltage Range
28V	2	18 – 50V
270V	6	125 – 400V

ComPACs can be configured in 1-up, 2-up or 3-up packages with total output power limited to the maximum power of individual VI-200 or MI-200 series converters. Output voltages may be trimmed by the user.

Output Power: The maximum total power which is delivered from the ComPAC is:

Nominal Input Voltage	Total Output Power		
	1-Up	2-Up	3-Up
24V and 24V (wide)	150W	300W	450W
28V, 270V (military)	100W	200W	300W
48V and 48V (wide), 300V	200W	400W	600W

Weight:

1-Up: 1.2lbs [540g]
 2-Up: 2.4lbs [1,080g]
 3-Up: 3.6lbs [1,630g]

Operating Case Temperature:

E-Grade: –10 to +85°C
 C-Grade: –25 to +85°C
 I-Grade: –40 to +85°C
 M-Grade: –55 to +85°C

Overall Efficiency: The overall efficiency of the ComPAC is approximately 1% less than the efficiency of the Vicor DC-DC converters (typical efficiencies: 77% for 2V output, 81% for 5V output and 83% for 12 – 48V output).

EMC Performance, Conducted EMC: The ComPAC will conform to the following conducted EMC specifications on the input power leads:

- Telecom (24V, 48V inputs): Bellcore TR-TSY-000513, Issue 2 July 1987 and Rev. 1, December 1988. British Telecom Document BTR2511, Issue 2.
- Commercial (300V input): FCC Pt. 15 Subpt. J, Class A / VDE 0871 Class A.
- Military (28V, 270V): MIL-STD-461C
 Conducted Emissions: CE01, CE03, CE07
 Conducted Susceptibility: CS01, CS02, CS06

Radiated EMC: The ComPAC will conform to the following radiated specifications:

- Military: Radiated Emissions: RE02; Radiated Susceptibility: MIL-STD-461C, RS02, RS03.

Input Transient Protection: The input transient protection will suppress short term transients appearing on the input line. Refer to data sheet for applicable standards at vicorpower.com.

Input Surge Withstand: The 24V, 48V and 300V input ComPAC shall withstand, without damage or interruption of power, an input line surge shown below for a duration of 100ms from a source impedance of 500mΩ.

Extended Input OV Shut Down: Surge protection shall also shut down the ComPAC in the presence of sustained input surges (100 – 1,000ms) which would cause excessive dissipation or damage. The ComPAC will auto restart when the input overvoltage is removed.

Input Reverse Polarity Protection: The ComPAC's input is protected against reverse polarity. No damage will occur provided that external current limiting is present (i.e., fuse).

Output Short Circuit Protection: Output short circuit protection is provided by the current limiting of the Vicor DC-DC converters.

Undervoltage Lockout: The ComPAC incorporates an undervoltage lockout which will inhibit the output of all converters until the input line exceeds the brownout voltage specified for the converter input range.

Nominal Input Voltage	Undervoltage Lockout (V _{DC} , Typical)
24V	19
24V (wide)	17
28V	17
48V	41
48V (wide)	35
270V	121
300V	188

Following startup, the undervoltage lockout will inhibit the converter output(s) should the input drop roughly 8 – 10 V below the UV lockout limits stated above.

Recommended Input Line Fusing

The ComPAC must be fused externally. The table below lists the fuse ratings for one, two and three-up units (maximum output 200, 400 and 600W).

Nominal Input Voltage	Fuse Rating		
	1-Up	2-Up	3-Up
24V	10A / 32V	20A / 32V	30A / 32V
24V (wide)	12A / 32V	20A / 32V	30A / 32V
28V	10A / 250V	20A / 250V	30A / 125V
48V	8A / 60V	15A / 60V	25A / 60V
48V (wide)	6A / 100V	15A / 100V	25A / 100V
270V	2A / 250V	4A / 250V	6A / 250V
300V	2A / 250V	4A / 250V	6A / 250V

Recommended Input Wiring and Torque

Configuration	Wiring	Torque
1-Up	#16AWG	10in-lb
2-Up	#14AWG	15in-lb

Recommended Output Wiring

Use the output wire gauge that corresponds to the output current of the ComPAC unit:

Output Current & Corresponding Wiring					
105 – 160A	#4	26 – 40A	#10	7 – 10A	#16
66 – 104A	#6	16 – 25A	#12	4 – 6A	#18
41 – 65A	#8	11 – 15A	#14	0 – 3A	#20

Long cable runs, or wires in large bundles will require heavier cable to avoid excessive voltage drops or overheating.

Grounding

For safe operation, the ComPAC unit must be grounded. Connect a ground lead to the terminal marked (GND). Use the same wire gauge as that specified for your ComPAC unit’s input voltage connections.

Master Disable

The ComPAC incorporates an optically isolated Master Disable input which will shut down the ComPAC output when a current is driven through the disable terminals.

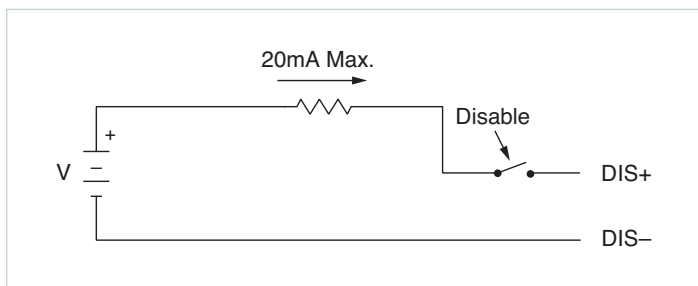

Figure 17.1 — ComPAC module disable

Disable Current

- 4mA DC minimum for 1-up ComPAC
- 8mA DC minimum for 2-up ComPAC
- 12mA DC minimum for 3-up ComPAC

Trimming

The nominal output voltage of the ComPAC can be adjusted from 110 to 50% of nominal voltage. Refer to [Output Voltage Trimming](#), Section 5, for external resistor values. Do not trim the outputs higher than 110% of their nominal output power (output overvoltage protection may trigger). When the output is trimmed up, do not exceed its maximum rated output power.

NOTE: 10V, 12V and 15V outputs, standard trim range ±10%, 3.3V output trim range 2.20 – 3.63V.

Remote Sensing

+SENSE and –SENSE must be connected locally or remotely.

Output Terminal Connections

A hardware kit with parts for output terminal connections is provided with each ComPAC unit. The following drawing shows the assembly of those parts for the proper connection of metal power terminals. Assembly for PCB power terminals is the same except that they do not require an external tooth lockwasher. See Figure 17.2 for the recommended torque level for each stud size.

Terminal and Product Model	Terminal Style	Stud Size	Recommended Torque
–OUT, +OUT Terminals			
LC, PC, RC Series	PCB	8-32 UNC	10in-lbs [1.1N·m]
MC and NC Series	Metal	10-32 UNC	15in-lbs [1.7N·m]
QC Series	PCB	8-32 UNC	10in-lbs [1.1N·m]
	Metal	10-32 UNC	15in-lbs [1.7N·m]
–SENSE, +SENSE, TRIM Terminals			
All models	Sized to accept Amp Faston® insulated receptical #2-520184-2.		

Figure 17.2 — Output terminal connections

Thermal Data

Operating Ambient Temperature: Depends on factors such as output power, availability of forced air, and mounting technique. **Do not** allow the ComPAC to exceed its maximum operating temperature, which is reached when the case is 85°C. Temperature measured at center of heat sink. (Full power can be delivered up to this temperature.) Refer to Section 21, [Thermal Curves](#), to determine the maximum ambient temperature for your application.

Note: To ensure proper heat transfer from the internal module(s) to the heat sink, the mounting holes through the heat sink must be properly torqued at all times during operation. If the unit is operated unmounted, insert a #6 or metric M3.5 flathead screw through each hole from below and secure with a nut on top, torqued to 6lb-in [0.83N·m].

Thermal Impedance, Free Convection:

Thermal resistance baseplate to air.

Mounting Type	Thermal Resistance (°C / W)		
	1-Up	2-Up	3-Up
Vertical	2.44	1.17	0.76
Horizontal	3.60	1.70	1.35

Forced Convection:

Thermal resistance baseplate to air (horizontal mount):

Thermal Resistance (°C / W)			Airflow (LFM)
1-Up	2-Up	3-Up	
3.6	1.7	1.35	0
2.7	1.4	1.26	50
2.3	1.3	1.11	100
1.6	0.97	0.82	250
1.15	0.70	0.58	500
0.9	0.54	0.46	750
0.78	0.45	0.38	1,000

Note: A 1.37in [34,8mm] heat sink, option H1, is also available.

Overview

Vicor's FlatPAC consists of an offline single phase AC front end and one, two or three VI-26x / VI-B6x Family DC-DC converter modules (1-up, 2-up, 3-up), combined in an integrated mechanical assembly. This assembly provides a complete, high-efficiency, offline switching power supply delivering power up to 600W. The offline front end provides rectification and filtering of the AC input, delivering a nominal unregulated $300V_{DC}$ bus as input to the VI-26x / VI-B6x Family converter modules. The front end control circuit will automatically strap the bridge as a voltage doubler for $115V_{AC}$ operation or as a full bridge for $230V_{AC}$ operation.

Circuit Operation

AC line voltage is applied via an agency-approved terminal block providing AC mains (L1, L2/N and GND). Current in the L1 lead is applied to a 15A / 250V fuse for the 3-up FlatPAC, a 12A / 250V fuse for the 2-up FlatPAC and a 8A / 250V fuse for the 1-up FlatPAC. This current is interrupted only in the event of a catastrophic failure of a main power component internal to the FlatPAC.

The input current beyond the fuse is passed through an EMC filter designed to meet conducted noise limits of FCC Part 15 EN55022 Class B for the 2-up and 3-up versions. At start-up, AC inrush current is limited by a PTC thermistor prior to being passed to the main energy storage capacitors. This PTC thermistor serves as both an inrush current limiter on power-up and a current limiting shutdown device in the event of a line overvoltage condition. The PTC is shunted out shortly after initial power-up by a pair of inverse parallel SCRs on the 3-up FlatPAC (TRIAC for the 1-up and 2-up FlatPAC), controlled by an opto-TRIAC coupler driven by a DC bus voltage sense circuit. The main rectifiers and filter capacitors are arranged in a conventional selectable configuration and act as either a full wave bridge or voltage doubler, delivering a nominal $300V_{DC}$ to the converter modules.

At initial power-up, the front end is configured for 230V operation and the PTC inrush limiter permits the main storage capacitors to charge up at a controlled rate toward full operating DC bus potential. If the bus voltage is below the operating threshold for the converter, the unit will autostrap for 115V operation. The autostrapping function is performed by a control circuit and TRIAC (dual SCRs on 3-up unit) which configures the front end from a full wave bridge to a voltage doubler. Once the unit autostraps for 230V operation, it will be necessary to recycle the AC power to allow operation at 115 V. If the unit is operating in the 115V mode and a long duration transient is applied to the FlatPAC ($>150V_{AC}$ for 50ms), the unit will autostrap for 230V operation.

The control circuit maintains the converter GATE IN pins low, the PTC shunt inactive and the AC-OK and BUS-OK outputs in FAIL status until the DC bus potential reaches a minimum threshold at which full power and hold-up can be delivered. The GATE IN terminals of all Driver modules internal to the FlatPAC are FET-controlled by a logical replica of the BUS-OK status line, and as such will inhibit converter operation at power-up until the DC bus potential has settled to full operating level. The converters are then enabled and the PTC shunt activated.

The AC-OK and BUS-OK status lines go to their respective active states almost simultaneously on initial power-up. AC-OK will de-assert prior to BUS-OK on loss of AC input, providing advance warning of impending DC failure should the AC line not return prior to the expiration of the ride-through time (a function of both load and line voltage).

The front-end output is bled down automatically after loss of AC input, as the logic circuit operating power is derived from a bleed path across the DC output bus. Wait two minutes before reapplying input after shutdown. Input voltage to the converters is made via fast-acting 3A / 250V Buss PC-Tron fuses in each positive input lead. The fuse will clear rapidly and protect the front-end from damage in the event of a module input short.

Input overvoltage sensing and protection is performed by a voltage sensing circuit connected across the DC bus. In the event of an overvoltage condition, a SCR / PTC combination will simultaneously disable the drive for the TRIAC / SCR PTC shunt, disable the converters and apply a load across the DC bus. Normal operation resumes when the input voltage falls within the normal operating range when operated from a $230V_{AC}$ source.

A Master Disable function is incorporated in the 2-up and 3-up FlatPAC (MOD DIS+, MOD DIS-). This optically isolated input will disable the output of all converters simultaneously. Applying a current to this input will disable the converters. This disable current should be limited to 30mA maximum by an external control element.

FlatPAC AC-OK and BUS-OK Status Outputs, MOD-DIS Input (2-up and 3-up only)

The BUS-OK and AC-OK outputs provide the user with both an optically isolated status indication of the internal DC bus condition and advance warning of pending DC bus drop-out due to AC line loss. These outputs, in system applications, can provide power supply status, switch in (standby) backup sources or initiate "power-down" sequences to save volatile memory contents in the event of AC line loss. The MOD-DIS input is an optically coupled input and allows for remote disabling of the outputs of 2-up and 3-up FlatPACs.

BUS-OK: An internal replica of BUS-OK is wired to the GATE IN input of all internal Driver modules. The modules will be disabled (no DC output) during initial power-up of the FlatPAC until the internal DC input bus voltage to the DC-DC converters is sufficient to support fully-loaded operation. The BUS-OK status output reflects the status of this inhibit function. This same logic circuit will shut down the converters when the internal DC bus voltage is insufficient to support proper loaded operation. This shut down will occur during normal power down, AC line dropouts of duration exceeding the hold-up time, or internal faults causing the internal DC bus voltage at the input of the converters to collapse.

AC-OK: This output is provided primarily as an advance warning of a potential DC BUS-OK shut down due to loss of AC line or an internal fault. A minimum advance warning time of 5ms is provided at 90V_{AC} and full load.

MOD-DIS+, MOD-DIS-

The Module Disable function will disable the output(s) of the 2-up and 3-up FlatPACs. The supply is disabled by applying current to the MOD-DIS+ / MOD-DIS- input. The minimum input current for disabling the supplies is 1mA. The maximum allowable current is 30mA.

Electrical Connections

Status output pairs AC-OK+, AC-OK- and BUS-OK+, BUS-OK- are the collectors (+) and emitters (-) of NPN optoisolator output transistors (one optoisolator per status signal). The collector terminals AC-OK+ and BUS-OK+ of the optocouplers, in a typical application, can be connected via current limiting resistors to a source no greater than 70V_{DC}. These resistors should limit the maximum current to the optocoupler output transistors to 1.5mA. The emitter terminals AC-OK- and BUS-OK- are connected to the return of the external source. The status OK condition will set the optocoupler output transistors in saturation and are capable of sinking up to 1.5mA with a V_{CE} saturation voltage of 0.4V. Users should be cautioned that although the output of the FlatPAC can be used as the pull-up source, shortly after BUS-OK changes from OK (saturated) to NOT OK (high Z), the pull-up voltage will be shut down. It is thus advisable to provide a capacitive reservoir, if the pull-up source is one of the FlatPAC's outputs, in order to maintain the pull-up potential after loss of DC current output. Use edge sensing logic to detect assertion of logic outputs, or a separate source of bias supply voltage (i.e., backup batteries) to provide a safe pull-up voltage source regardless of the AC line status.

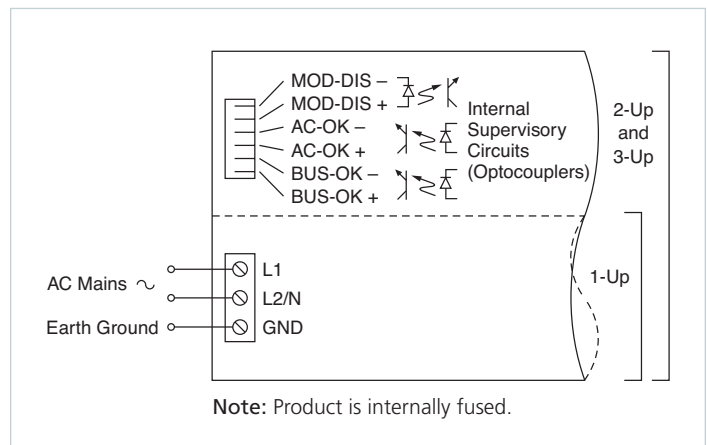

Figure 18.1 — AC mains and supervisory connections

Mod-Dis Input: Apply a current of 1 – 30mA to disable output. Forward voltage drop of internal opto diode is 1.65V max. at 30mA max.

AC-OK and BUS-OK Status Outputs: Outputs low when OK. V_{CE} sat. = <0.4V at 1.5mA. Maximum external pull up is 70V_{DC}. AC-OK and BUS-OK signals are isolated and can have different reference levels.

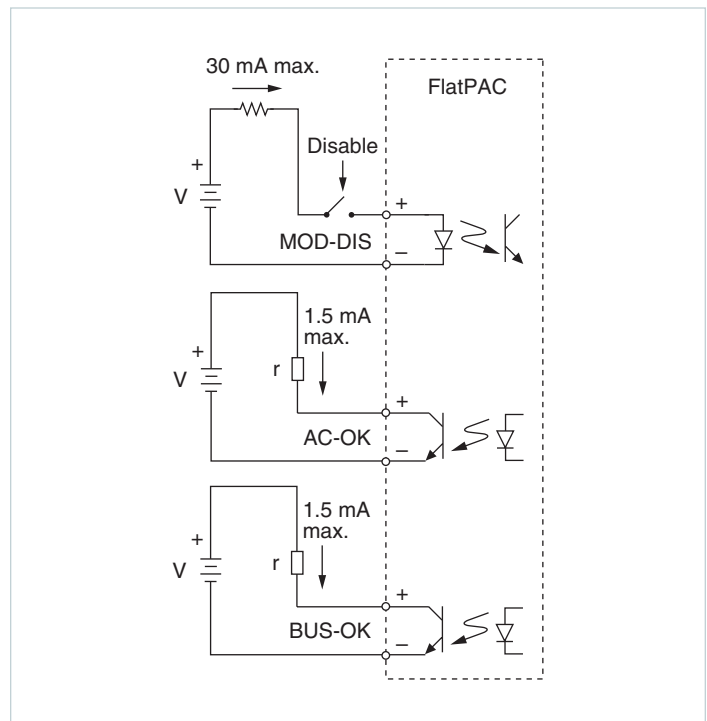

Figure 18.2 — External supervisory functions (2-up and 3-up models only)

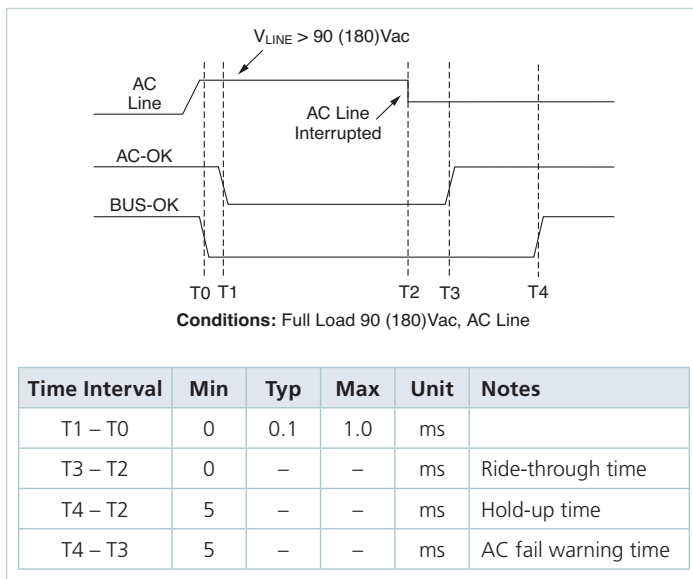

Figure 18.3 — Timing diagram, status signals (2-up and 3-up models only)

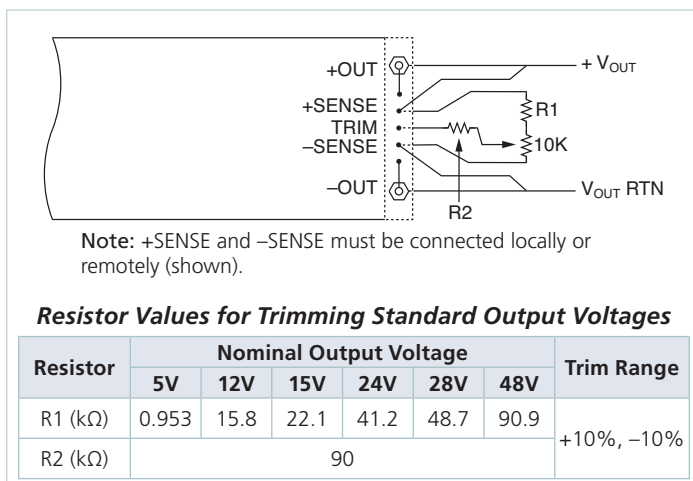

Figure 18.4 — Output SENSE and TRIM (all models with VI-200s)

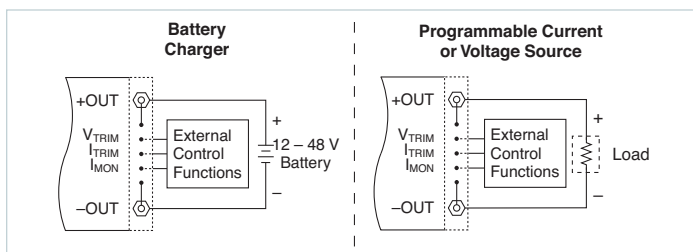

Figure 18.5 — Typical applications (models with BatMods only)

Fusing: The FlatPAC’s internal fuses are not user-replaceable. Please return the unit to vendor if servicing is necessary.

Grounding: To satisfy IEC950 Class I grounding requirements, connect a ground lead to the terminal marked ⚡(GND). For 1-up FlatPAC models (max. output 200W), use 1.5mm² / #16AWG wire; for 2-up and 3-up models (max. output 400W and 600W), use 2.5mm² / #14AWG wire.

Input Voltage Connections: Connect the line voltage to L1 (hot) and L2N (neutral). For 1-up FlatPAC models (max. output 200W), use #16AWG input wire; for 2-up and 3-up models (max. output 400W and 600W), use #14AWG input wire. Recommended connector screw torque is 5 to 7in·lbs (0.5 – 0.8N·m). Recommended strip length is 8mm. Use your FlatPAC model only with the corresponding input voltages and frequencies shown in the table below.

Product Grade	Model	90 – 132V _{AC}	180 – 264V _{AC}
C-Grade	VlxU-Cx	47 – 63Hz	
I-Grade	VI-xU-lx	47 – 440Hz	

Output Wire Gauge: Use the output wire gauge that corresponds to the output current of your Autoranging FlatPAC unit, below: Do not loosen bottom nut.

Output Current & Corresponding Wiring					
100 – 160A	#2	30 – 50A	#8	10 – 15A	#14
75 – 100A	#4	20 – 30A	#10	6 – 10A	#16
50 – 75A	#6	15 – 20A	#12	0 – 6A	#18

Long cable runs, or wires in large bundles will require heavier cable to avoid excessive voltage drops or overheating.

Output Voltage Trimming: Do not trim the outputs higher than 110% of their nominal output voltage. When an output is trimmed up, do not exceed its maximum rated output power. (refer to Section 5)

Operating Temperature: Do not allow the FlatPAC to exceed its maximum operating temperature, which is reached when the heat sink is 85°C. (Full power can be delivered up to this temperature.) Heat sink temperature is a function of the output power and voltage of the supply, ambient temperature, and airflow across the heat sink. Always use worst-case conditions when calculating operating temperature.

Note 1: To ensure proper heat transfer from the internal module(s) to the heat sink, the mounting holes through the heat sink (two, three, and four holes on 1-up, 2-up and 3-up models, respectively) must contain torqued screws at all times during operation, whether or not the unit is mounted. If the unit is operated unmounted, insert a #6 or M3.5 panhead screw through each hole from below and secure with a nut on top, torqued to 6in·lbs [0.7 N·m].

Note 2: All FlatPAC models are available with a conduction cooled flat plate instead of the top heat sink. Go to vicorpower.com for outline drawings.

Input / Output Retrofit Connections: A hardware kit, available from Vicor, allows the input and output supervisory terminals to be connected in the same manner as for the earlier style FlatPAC (2-up model only). The retrofit output terminals are sized to accept AMP Faston® insulated receptacle #2-520184-2.

Overview – PFC FlatPAC

The PFC FlatPAC consists of a universal input (85-264V_{AC}) AC front end and one Maxi DC-DC converter in an integrated mechanical assembly providing up to 575W of power. Using the Vicor Harmonic Attenuator Module (HAM) and integrated filtering, the PFC FlatPAC meets EN61000-3-2 harmonic current limits and 0.99 power factor. The internal filtering provides compliance to EN55022-A conducted EMI.

The PFC FlatPAC will accept an input voltage of 85 – 264V_{AC}, derate power at 9W/V_{RMS} as shown in Figure 19.1.

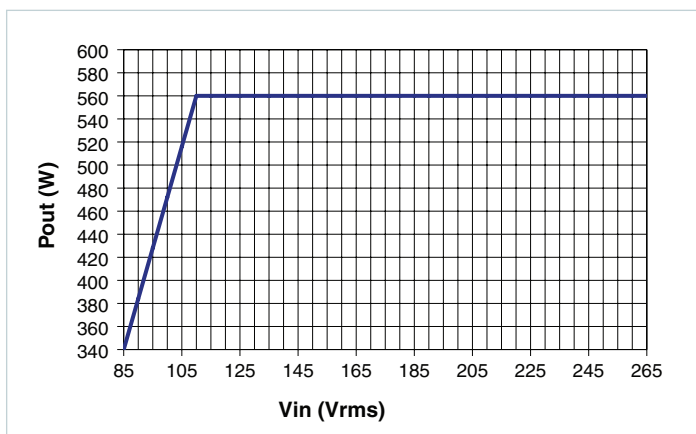

Figure 19.1 — PFC FlatPAC output power vs. input voltage

Circuit Operation

AC line voltage is applied via an agency-approved terminal block providing AC mains (L1, L2/N and GND). Current in the L1 lead is applied to a 15A / 250V internal fuse. This current is interrupted only in the event of a catastrophic failure of a main power component internal to the PFC FlatPAC.

The input current beyond the fuse is passed through an EMC filter designed to meet conducted noise limits of FCC Part 15 EN55022 Class A. At start up, AC inrush current is limited by the HAM’s internal circuitry prior to being passed to the main energy storage capacitors.

The DC-DC converter is held off until the internal DC bus potential has settled to full operating level. The converter is then enabled.

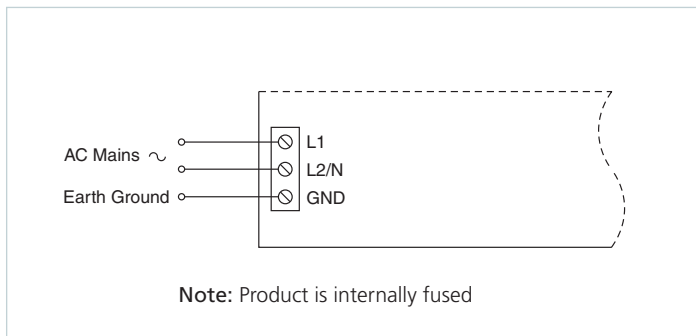

Figure 19.2 — AC mains connections

Fusing: The PFC FlatPAC’s internal fuse is not user-replaceable.

Grounding: To satisfy IEC950 Class I grounding requirements, connect a ground lead to the terminal marked (GND). Use 2.5mm² / #14AWG wire.

Input Voltage Connections: Connect the line voltage to L1 (hot) and L2N (neutral). Use #14AWG input wire. Recommended connector screw torque is 5 – 7in·lbs [0.5 – 0.8 N·m]. Recommended strip length is 8mm. Refer to Figure 19.2.

Output Wire Gauge: Use the output wire gauge that corresponds to the output current of your FlatPAC unit, below: Do not loosen bottom nut. Long cable runs, or wires in large bundles will require heavier cable to avoid excessive voltage drops or overheating.

Output Current & Corresponding Wiring					
100 – 160A	#2	30 – 50A	#8	10 – 15A	#14
75 – 100A	#4	20 – 30A	#10	6 – 10A	#16
50 – 75A	#6	15 – 20A	#12	0 – 6A	#18

Output Voltage Trimming: The Maxi converters used in the PFC FlatPAC have a wide trim range of +10% to –90%. See the Maxi, Mini, Micro Design Guide for details.

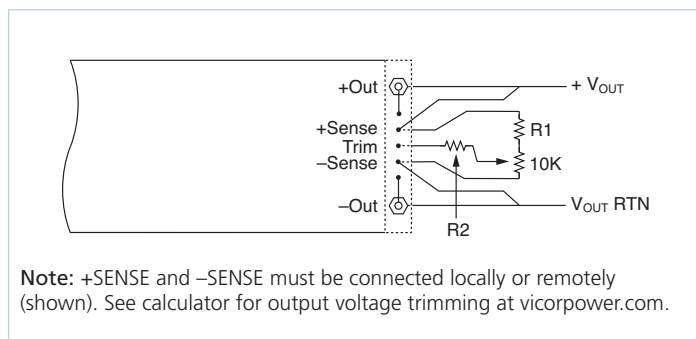

Note: +SENSE and –SENSE must be connected locally or remotely (shown). See calculator for output voltage trimming at vicorpower.com.

Figure 19.3 — Output sense and trim

Operating Temperature: Do not allow the PFC FlatPAC to exceed its maximum operating temperature, which is reached when the heat sink is 85°C. (Full power can be delivered up to this temperature.) Heat sink temperature is a function of the output power and voltage of the supply, ambient temperature, and airflow across the heat sink. Always use worst-case conditions when calculating operating temperature.

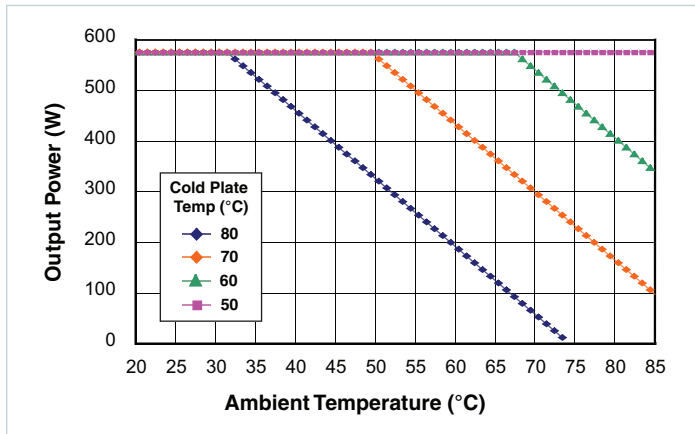

Figure 19.4 — Power de-rating conduction-cooled option

Note 1: To ensure proper heat transfer from the internal module(s) to the heat sink, the mounting holes through the heat sink (three holes on 2-up models) must contain torqued screws at all times during operation, whether or not the unit is mounted. If the unit is operated unmounted, insert a #6 or M3.5 panhead screw through each hole from below and secure with a nut on top, torqued to 6in-lbs [0.7N·m].

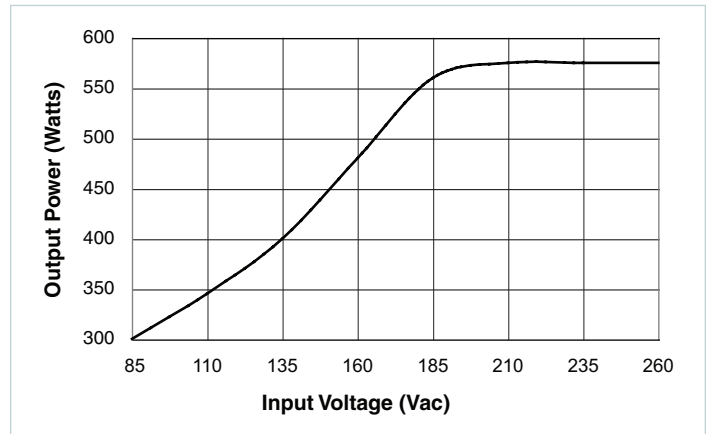

Figure 19.5 — Output power start-up de-rating at -30°C (I-Grade only); five minute warm up required before full power (see Figure 19.1) is available

Note 2: All PFC FlatPAC models are available with a conduction-cooled flat plate instead of the top heat sink. Go to vicorpower.com for outline drawings. Refer to Figure 19.4 for additional de-ratings for the -cc variants.

Overview

Simplified thermal management is one of the benefits of using Vicor converters. High operating efficiency minimizes heat loss, and the low profile package features an easily accessible, electrically isolated thermal interface surface.

Proper thermal management pays dividends in terms of improved converter and system MTBFs, smaller size and lower product life-cycle costs. The following pages provide guidelines for achieving effective thermal management of Vicor converters.

Efficiency and Dissipated Power

A DC-DC converter takes power from an input source and converts it into regulated output power for delivery to a load. Not all of the input power is converted to output power however; some is dissipated as heat within the converter. The ratio of delivered output power to converter input power is defined as the converter’s efficiency. Efficiency is a basic figure of merit that can be used to relate power dissipation directly to converter output power, as illustrated in Figures 20.1a and 20.1b.

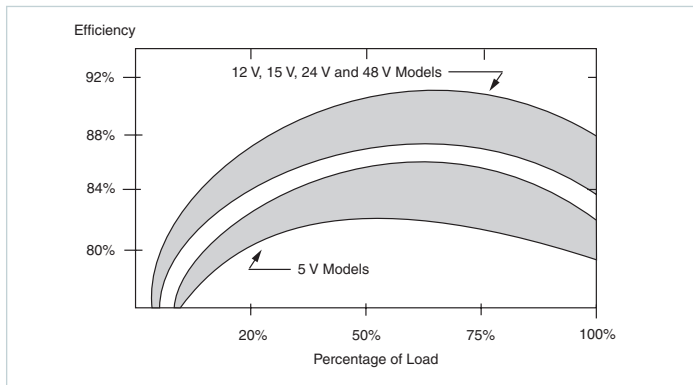

Figure 20.1a — Module efficiency

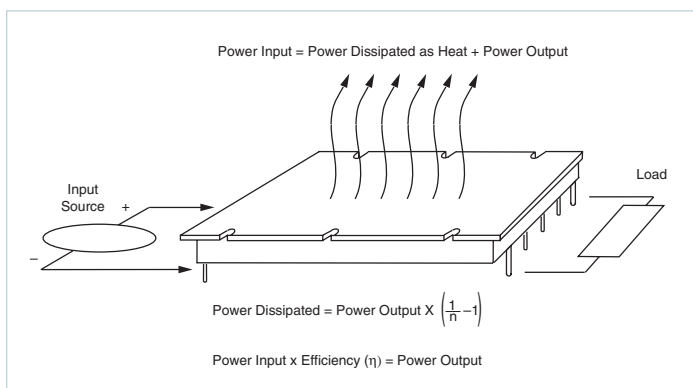

Figure 20.1b — Dissipated power

The first step in evaluating cooling requirements is to calculate worst-case dissipation based on converter efficiency and worst-case anticipated load power. Clearly, higher efficiency will translate into lower power dissipation and simplify the cooling problem. Vicor converters are among the most efficient converters available, with full load efficiencies typically in excess of 80%.

Removing Heat From Vicor Converters

Heat is removed from Vicor converters through the flat metal baseplate on top of the module. The baseplate is thermally coupled to, but electrically isolated from, all internal heat-generating components. The basic thermal design problem is to transfer heat from the baseplate into the surrounding environment as a means of maintaining baseplate temperature at or below rated maximum.

Heat energy is transferred from regions of high temperature to regions of low temperature via three basic mechanisms; radiation, conduction and convection.

Radiation: Electromagnetic transfer of heat between masses at different temperatures.

Conduction: Transfer of heat through a solid medium.

Convection: Transfer of heat through the medium of a fluid; typically air.

All three of these heat transfer mechanisms are active to some degree in every application. Convection will be the dominant heat transfer mechanism in most applications. Nondominant effects will provide an added contribution to cooling; in some cases, however, they may result in undesirable and unanticipated thermal interactions between components and subassemblies.

All three of these mechanisms should be given consideration when developing a successful cooling strategy.

Radiation

Radiant heat transfer occurs continuously between objects at different temperatures that are exposed to each other. The net effect on the temperature of an individual part is dependent on a great many factors, including its temperature relative to other parts, relative part orientations, surface finishes and spacing. The difficulty in quantifying many of these factors, combined with the universal presence of radiant energy exchange, makes calculation of radiational temperature effects both a complex and generally imprecise task.

Temperature differentials encountered in practical applications of Vicor converters are never large enough to cause radiational cooling to be the dominant heat transfer mechanism. Radiation will account for less than 10% of total heat transfer in the majority of cases. For these reasons, the presence of radiant cooling is often assumed to provide safety margins over and above the dominant cooling mechanism, and detailed consideration of its effects are neglected. A valid assumption, in most cases, is that the converter will be warmer than its surroundings and radiant energy transfer will aid cooling. In some cases, however, nearby objects (PC boards, power resistors, etc.) may be much hotter than the converter and net radiant energy transfer may actually increase the converter's temperature.

Surveying the relative positions and estimated temperatures of converters and surrounding parts is advisable as a means of anticipating the potential effects of radiant transfer. In cases where hot components are in close proximity to the converter, the use of interposing barriers can generally moderate undesirable radiational heating effects.

Conduction

In most applications, heat will be conducted from the baseplate into an attached heat sink or heat conducting member. Heat conducted across the interface between the baseplate and mating member will result in a temperature drop which must be controlled. As shown in Figure 20.2, the interface can be modeled as a "thermal resistance" in series with the dissipated power flow. The baseplate temperature will be the sum of the temperature rise in the interface and the temperature of the member to which the baseplate is attached.

Temperature rise across a surface interface can be significant if not controlled. The area of the interface should be as large as possible, and the surface flatness of the attached member should be within 5mils. Thermal compound or a thermal pad should be used to fill surface irregularities. Thermal resistance across surface interfaces can be held to under 0.1°C/Watt with proper measures.

Many applications require that heat be conducted from the baseplate of the converter to a "remote" dissipative surface via a thermally conductive member. The resulting baseplate temperature will be the sum of the temperature of the dissipative surface, the temperature rise in the heat conducting member, and the rises across the two surface interfaces. The thermal resistance of the conductive member is proportional to its length, and inversely proportional to both its cross-sectional area and thermal conductivity (Figure 20.3). Minimizing total temperature rise is dependent on controlling interface resistance, as described above, and controlling the thermal resistance of the transfer member through appropriate material selection and dimensioning.

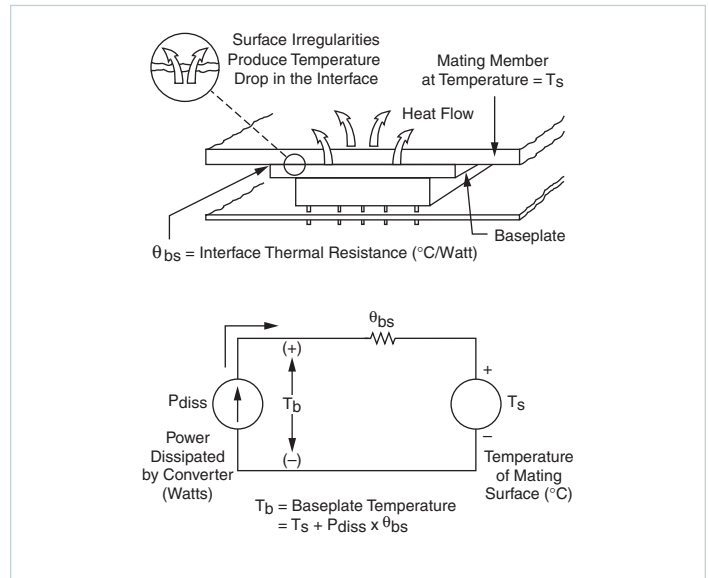

Figure 20.2 — Baseplate thermal considerations

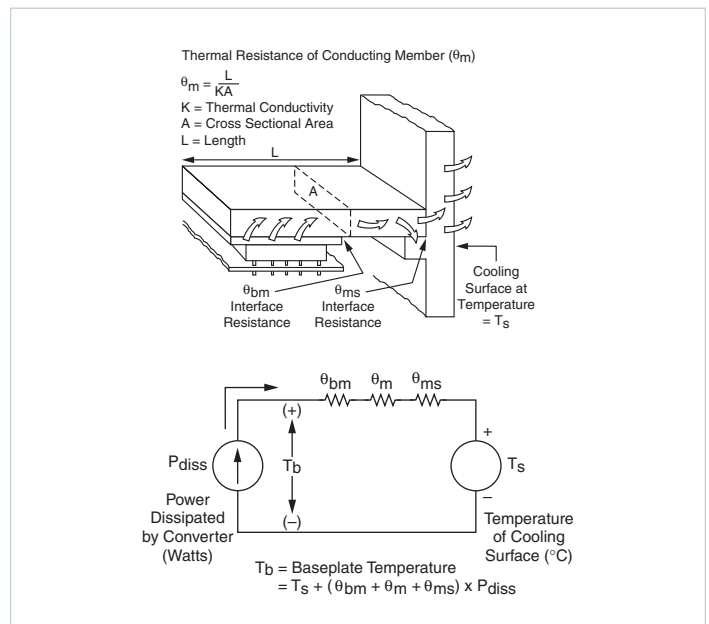

Figure 20.3 — Interface thermal considerations

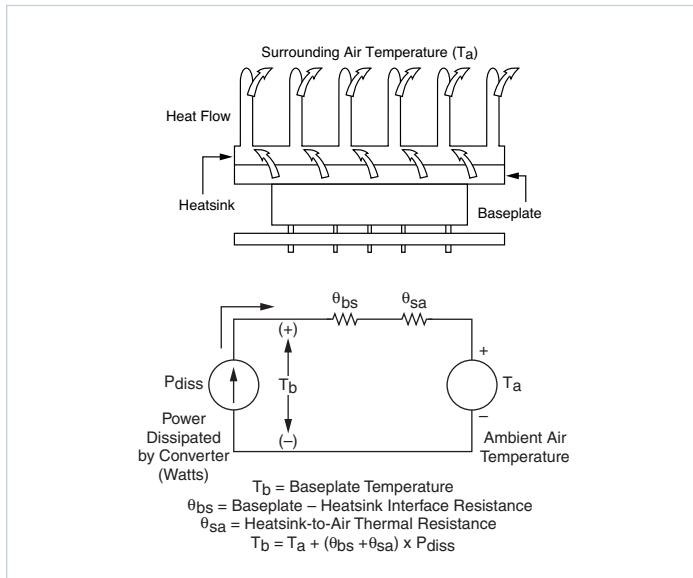

Figure 20.4 — Heat sink thermal considerations

Convection

Convective heat transfer into air is a common method for cooling Vicor converters. “Free” or “natural” convection refers to heat transfer from a dissipative surface into a cooler surrounding mass of otherwise still air; forced convection refers to heat transfer into a moving air stream.

The convection cooling model is shown in Figure 20.4. Baseplate temperature depends on the temperature of the air, total dissipated power and the values of two thermal resistances; the thermal resistance of the surface interface between the baseplate and the heat sink, and the heat sink-to-air thermal resistance. Surface interface resistance can be minimized as discussed under Conduction. The heat sink-to-air resistance is dependent on a variety of factors including heat sink material and geometry, air temperature, air density and air flow rate. Fortunately, thermal resistance data is available for a very wide range of standard heat sinks for use in both free and forced convection applications. The following sections will provide guidelines for both free and forced convection cooling of Vicor converters and configurables.

Free Convection

The benefits of free convection include low cost of implementation, no need for fans, and the inherent reliability of the cooling process. Compared to forced air cooling, however, free convection will require more heat sink volume to achieve an equivalent baseplate temperature.

To select a suitable heat sink for free convection cooling, follow these steps:

1. Determine the power to be dissipated by the heat sink. This should be based upon converter efficiency and worst-case converter power output using the formula given in the section on Module Efficiency and Dissipated Power. (Figures 20.1a and 20.1b)

$$Power\ Dissipated = Power\ Output \cdot \left(\frac{1}{\eta} - 1 \right)$$

2. Estimate or experimentally determine the surface interface thermal resistance. Use of thermal compound or a thermal pad is recommended to minimize this resistance. An estimate of 0.2°C/Watt should provide an adequate safety margin.
3. Referencing Figure 20.4, we can derive the following formula for heat sink-to-air thermal resistance:

$$\theta_{sa} = \left(\frac{T_B - T_A}{P_{DISS}} \right) - \theta_{BS}$$

Where:

T_A = Worst case anticipated operating ambient air temperature.

θ_{BS} = Surface interface thermal resistance, from Step 2.

P_{DISS} = Worst-case power dissipation, from Step 1.

T_B = Baseplate temperature.

Start with a value of $T_B = 85^\circ\text{C}$ (or 100°C , VI-J00) to determine the maximum acceptable heat sink-to-air thermal resistance.

4. Select several heat sinks that appear physically acceptable for the application. Using data provided, obtain values for their free convection thermal resistance, preferably at worst-case ambient temperature, T_A . If values obtained are less than the value calculated in Step 3, go on to Step 5. If the values are greater, then either a physically larger heat sink will be required or a different cooling method will need to be used (i.e., forced air, etc.).
5. Select the heat sink with the lowest available thermal resistance consistent with space and cost limits. Keep in mind that small reductions in baseplate temperature produce dramatic improvements in MTBF.
6. Baseplate temperature can be estimated by using the following formula:

$$T_B = T_A + P_{DISS} \cdot (\theta_{BS} + \theta_{SA})$$

7. Test to verify that performance is in line with expectations.

Heat sink data is almost always given for vertical fin orientation. Orienting the fins horizontally will reduce cooling effectiveness. If horizontal mounting is mandatory, obtain relevant heat sink performance data or use forced convection cooling.

Free convection depends on air movement caused by heat-induced density changes. Thermal resistance data is dependent on the heat sink fins being completely exposed to the ambient air without any significant interference to air flow at the ends of or along the length of the fins. If packaging will tend to block or baffle air movement over the fins, a larger heat sink might be required. In the worst case, free convection may be ineffective. Make sure that the fins are well exposed to ambient air.

It is not necessary to limit the size of the heat sink to the size of the baseplate. Heat sinks with footprints larger than the baseplate area can often be used to advantage. In the latter case, heat must be conducted along the base surface of the heat sink to get to the outer fins, so don't count on achieving full cooling capability. Also, several modules can be mounted to a common heat sink, but cooling calculations must now take into account total power dissipation with consideration given to possible localized overheating if worst-case converter power dissipations are greatly imbalanced. When securing a PC board containing two or more converters to a heat sink, it is good practice to use sockets on the converter pins to allow for mechanical alignment. If sockets are not used, be sure to mount the converters first mechanically, then solder the units in place. A fixture should be used to maintain alignment if soldering must be performed before attachment.

When mounting heat sinks to Vicor modules, use #6 or M3.5 screws torqued uniformly through the mounting slots provided. The following tightening sequence should be used:

- Lightly finger-tighten all screws
- Torque screws to 6in-lbs [0.7N·m] per Figure 20.5.

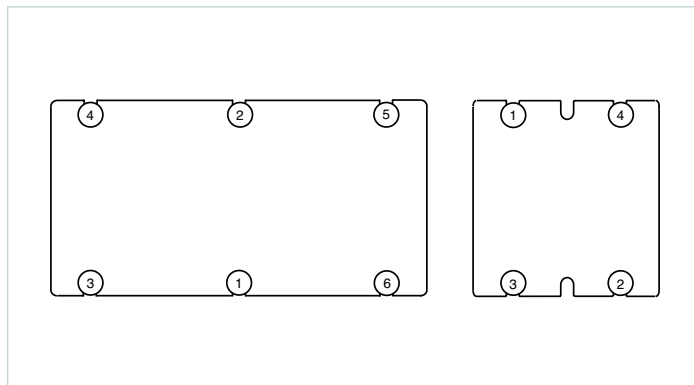

Figure 20.5 — Heat sink torquing sequence VI-200 / VI-J00

Multiple Modules Using Common Fasteners: The following mounting scheme should be used to attach modules to a heat sink for two or more modules. A large, heavy washer should be used on the common fasteners to distribute the mounting force equally between modules. The torquing sequence shown in Figure 20.6 can easily be expanded from two to any number of modules. An array of three is shown.

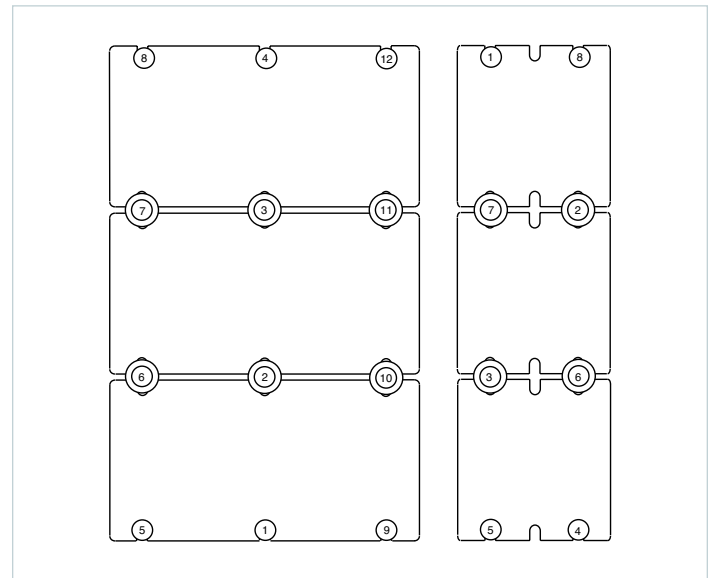

Figure 20.6 — Torquing sequence, multiple VI-200 / VI-J00 converters

Forced Convection

Forced air can make a great difference in cooling effectiveness. Heat sink-to-air thermal resistance can be improved by as much as an order of magnitude when compared to free convection performance, by using suitable heat sinks. Consider the following data for baseplate-to-air thermal resistance (no heat sink) of a VI-200 or VI-J00 module at various airflow rates:

Airflow	Baseplate-to-Air Thermal Resistance	
	VI-200	VI-J00
Free Air	5.1°C/W	8.1°C/W
200LFM	2.8°C/W	5.1°C/W
400LFM	1.8°C/W	2.7°C/W
600LFM	1.4°C/W	2.3°C/W
800LFM	1.2°C/W	1.7°C/W
1000LFM	1.0°C/W	1.4°C/W

Table 20.1 — Baseplate-to-airflow thermal resistance (no heat sink)

Forced air implies the use of fans. Many applications require that fans be used to achieve some desired combination of overall system reliability and packaging density. Industrial environments will require filters that must be changed regularly to maintain cooling efficiency, and neglecting to change a filter or the failure of the fan could cause the system to shut down or malfunction.

The steps involved in selecting a heat sink / fan combination for forced convection are essentially the same as those followed for free convection, with the additional requirement that the heat sink and fan be matched to achieve desired heat sink-to-air thermal resistance. Attention must also be paid to proper channeling of fan airflow so that maximum utilization of its cooling capability is realized. Selection of a heat sink / fan combination involves the following three steps:

1. Determine maximum acceptable heat sink-to-air thermal resistance by following the first three steps of the heat sink selection procedure given in the Free Convection section.
2. Selection of a heat sink / fan combination requires that forced convection data for both the heat sink and fan be available. Forced convection characteristics for heat sinks define both heat sink-to-air thermal resistance and pressure drop through the heat sink as a function of airflow. Fan characteristics define airflow as a function of pressure drop. The intersection point of the airflow versus pressure curves for the fan and heat sink will define the operating airflow through the heat sink. (Figure 20.7) The heat sink-to-air thermal resistance for this airflow may be read directly off the airflow versus resistance curve for the heat sink.

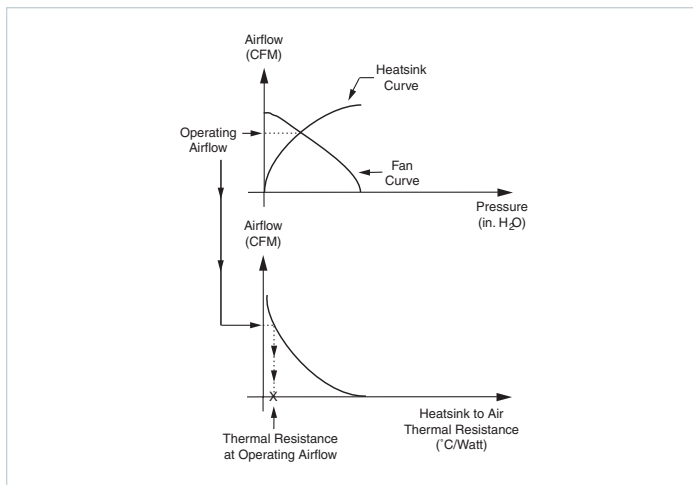

Figure 20.7 — Airflow vs. resistance

Finding and interpreting the operating point requires consideration of the following:

Units of pressure drop are generally given in inches of water. Units of fan airflow are in cubic feet per minute (CFM). Occasionally metric units are used, but conversion is straightforward.

Heat sink airflows may be given either in CFM or LFM (linear feet per minute). The conversion between LFM and CFM is dependent on the cross-sectional area through which air is flowing: $CFM = LFM \cdot Area$

The cross-sectional area between the fins is the area through which the total airflow must pass. (Figure 20.8) Correct interpretation of heat sink data requires that only the airflow through this area be considered. Simply pointing a fan at a heat sink will clearly not result in all of the flow going through the cooling cross-section of the sink; some channeling of air is usually required to get the full benefit of fan output.

The fan curves give output in CFM versus pressure drop. Fan pressure drop is the total of all drops encountered by the fan airflow. The heat sink, any ducting that is used, and air entry and exit channels all contribute to pressure drop. Pressure drop represents the work done by the fan in moving air through a region, so care should be taken to minimize unproductive pressure losses. Ensure that air entry and exit locations and internal air channels are not unduly constricted, and avoid sharp turns in airflow paths.

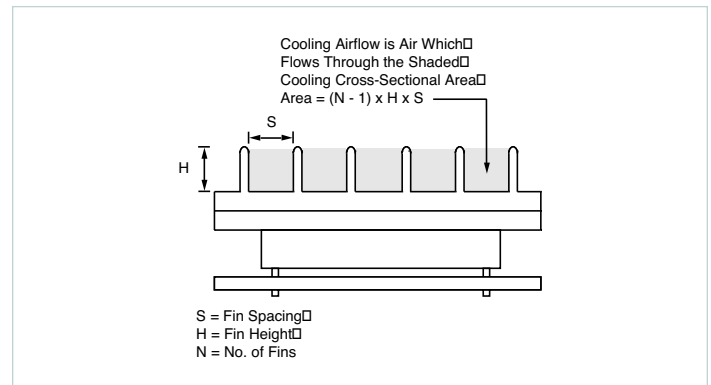

Figure 20.8 — Heat sink cross section

The thermal resistance that was determined by overlapping the fan and heat sink curves will represent an optimistic estimate since it assumes that all the fan output flows through the heat sink cooling cross section, and that all the pressure drop occurs along the heat sink. If the estimated thermal resistance is close to the minimum value determined in Step 1, then it is likely that a larger fan or different heat sink is required. This will not be a problem in most cases; relatively modest heat sinks and fans usually provide ample cooling.

Careful channeling and ducting of airflow as a means of both maximizing flow through the cooling cross-section of the heat sink and minimizing extraneous flow of air around the sink is well worth the small extra design effort required. Every degree of improvement in baseplate temperature results in significant improvement in MTBF. If you are paying for a fan, you may as well leverage it for all that it is worth.

3. Steps 5 through 7 in the Free Convection section will complete the heat sink selection process. Select the fan / heat sink combination with the lowest thermal resistance consistent with cost and space constraints, calculate the estimated baseplate temperature and test to verify.

Note: The values of θ_{SA} incorporating add-on or integral heat sinks include the baseplate-to-heat sink thermal resistance θ_{BA} . When using heat sinks from other sources, the thermal impedance baseplate-to-air will be the sum of the thermal impedance heat sink-to-air specified by the heat sink manufacturer and the baseplate-to-heat sink impedance from the following Thermal Impedance Charts that follow.

Thermal Impedance Table

Table usage: The forced convection thermal impedance data shown in the tables below assumes airflow through the heat sink fins. Actual airflow through the fins should be verified. For purposes of heat sink calculation, assume efficiencies of 81% for 5V outputs and 85% for 12V and above.

VI-200 MI-200 $\theta_{BS} = 0.2^\circ\text{C/W}$	Baseplate	Part #30089	Part #30775	Part #30090	Part #30780	Part #30193	Part #30194	SlimMod	FinMod -F1 / -F3	FinMod -F2 / -F4
		0.9"L Fins [a] [22,86mm]	0.7"L Fins [17,78mm]	0.9"T Fins [b] [22,86mm]	1.45"L Fins [36,83mm]	0.7"T Fins [17,78mm]	0.4"T Fins [10,16mm]			
$\theta_{SA} (\text{C/W})$										
Free Air	5.10	3.40	4.08	2.70	2.60	3.15	3.80	5.40	5.00	3.70
200LFM	2.80	1.50	1.80	1.10	1.00	1.28	1.55	3.20	2.40	1.80
400LFM	1.80	1.00	1.20	0.80	0.60	0.93	1.13	2.20	1.50	1.20
600LFM	1.40	0.80	0.96	0.60	0.50	0.70	0.84	1.60	1.10	0.90
800LFM	1.20	0.60	0.72	0.50	0.40	0.58	0.70	1.30	0.90	0.70
1000LFM	1.00	0.50	0.60	0.40	0.30	0.47	0.56	1.20	0.80	0.60

Table 20.2a — Thermal impedance for VI-200 / MI-200

VI-J00 MI-J00 $\theta_{BS} = 0.4^\circ\text{C/W}$	Baseplate	Part #30191	Part #30771	Part #30140	SlimMod	FinMod -F1 / -F3	FinMod -F2 / -F4
		0.9"L Fins [22,86mm]	0.9"L Fins [26,86mm]	0.4"T Fins [10,16mm]			
$\theta_{SA} (\text{C/W})$							
Free Air (H)	8.10	4.20	4.00	5.63	8.50	8.00	7.00
Free Air (V)	7.60	4.00	3.90	5.49	8.40	7.30	6.70
200LFM	5.10	1.60	1.60	2.25	5.50	5.00	2.70
400LFM	2.70	1.30	1.30	1.83	3.60	2.50	1.50
600LFM	2.30	0.90	0.90	1.27	2.90	2.10	1.20
800LFM	1.70	0.70	0.70	0.99	2.30	1.30	0.80
1000LFM	1.40	0.60	0.60	0.84	2.00	1.10	0.70

Table 20.2b — Thermal impedance for VI-J00 / MI-J00

Configurables (also applies to MI-CompAC and MI-MegaMod)	FlatPAC™ [c]			CompACT™ [c]			MegaMod™ [c]		
	θ_{BM} 0.1°C/W	θ_{BM} 0.05°C/W	θ_{BM} 0.03°C/W	θ_{BM} 0.1°C/W	θ_{BM} 0.05°C/W	θ_{BM} 0.03°C/W	θ_{BM} 0.1°C/W	θ_{BM} 0.05°C/W	θ_{BM} 0.03°C/W
	$\theta_{SA} (\text{C/W})$			$\theta_{SA} (\text{C/W})$			$\theta_{SA} (\text{C/W})$		
Free Air	2.1	1.3	1.0	3.6	1.7	1.4	4.4	2.1	1.7
50LFM	1.5	1.1	0.9	2.7	1.4	1.3	3.3	1.7	1.6
100LFM	1.2	0.9	0.7	2.3	1.3	1.1	2.8	1.6	1.3
250LFM	0.7	0.5	0.4	1.6	1.0	0.8	2.0	1.2	1.0
500LFM	0.4	0.3	0.3	1.2	0.7	0.6	1.5	0.9	0.7
750LFM	0.3	0.2	0.2	0.9	0.5	0.5	1.1	0.6	0.6
1000LFM	0.2	0.2	0.2	0.8	0.4	0.4	1.0	0.5	0.5

Table 20.2b — Thermal impedance for FlatPAC, CompACT / MI-CompAC and MegaMod / MI-MegaMod families

[a] Longitudinal fins

[b] Transverse fins

[c] Assumes uniform loading of two and three output units.

Definitions

T_{MAX} = maximum baseplate temperature
(Available from converter's data sheet, which can be found on vicorpower.com.)

T_A = ambient temperature

η = efficiency = P_{OUT} / P_{IN}
(Assume efficiencies of 81% for 5V outputs, 85% for 12V_{OUT} and above.)

θ_{BS} = baseplate-to-heat sink thermal resistance
(From thermal impedance tables)

θ_{SA} = heat sink-to-air thermal resistance
(From thermal impedance tables)

Thermal Equations

$$P_{DISS} = \text{Dissipated Power} = P_{OUT} \left(\frac{1}{\eta} - 1 \right)$$

$$\text{Airflow (LFM)} = \left(\frac{CFM}{Area} \right)$$

$$\text{Maximum Output Power} = \frac{T_{MAX} - T_A}{\theta_{SA} \left(\frac{1}{\eta} - 1 \right)}$$

$$\text{Maximum Thermal Impedance} = \frac{T_{MAX} - T_A}{P_{OUT} \left(\frac{1}{\eta} - 1 \right)}$$

$$\text{Maximum Ambient Temperature} = T_{MAX} - \theta_{SA} \cdot P_{OUT} \left(\frac{1}{\eta} - 1 \right)$$

$$\text{Temperature Rise} = \theta_{SA} \cdot P_{OUT} \left(\frac{1}{\eta} - 1 \right)$$

$$\text{Thermal Drop} = \theta_{BS} \cdot P_{OUT} \left(\frac{1}{\eta} - 1 \right)$$

Typical Examples**Example 1**

Determine the maximum output power for a 100W, VI-200 converter, no heat sink, delivering 5V in 400LFM at a maximum ambient temperature of 45°C.

$$\text{Maximum Output Power} = \frac{T_{MAX} - T_A}{\theta_{SA} \left(\frac{1}{\eta} - 1 \right)}$$

Where:

$$T_{MAX} = 85^\circ\text{C}$$

$$T_A = 45^\circ\text{C}$$

$$\theta_{SA} = 1.8^\circ\text{C/W}$$

$$\eta = 81\% = (0.81)$$

$$\begin{aligned} \text{Maximum Output Power} &= \frac{85 - 45}{1.8 \left(\frac{1}{0.81} - 1 \right)} \\ &= 95\text{W Max} \end{aligned}$$

Example 2

Determine the maximum thermal impedance of a 50W, VI-J00 converter, no heat sink, delivering 24V at 45W in free air convection at 55°C ambient.

$$\text{Maximum Thermal Impedance} = \frac{T_{MAX} - T_A}{P_{OUT} \left(\frac{1}{\eta} - 1 \right)}$$

Where:

$$T_{MAX} = 100^\circ\text{C}$$

$$T_A = 55^\circ\text{C}$$

$$P_{OUT} = 45\text{W}$$

$$\eta = 85\% = (0.85)$$

$$\begin{aligned} \text{Maximum Thermal Impedance} &= \frac{100 - 55}{45 \left(\frac{1}{0.85} - 1 \right)} \\ &= 5.7^\circ\text{C/W} \end{aligned}$$

Example 3

Determine the maximum ambient temperature of a 3-up FlatPAC™ delivering 12V at 600W in 500LFM with no additional conduction cooling to the chassis.

Maximum

$$\text{Ambient Temperature} = T_{MAX} - \theta_{SA} \cdot P_{OUT} \left(\frac{1}{\eta} - 1 \right)$$

Where:

$$T_{MAX} = 85^{\circ}\text{C}$$

$$\theta_{SA} = 0.3^{\circ}\text{C/W}$$

$$P_{OUT} = 600\text{W}$$

$$\eta = 85\% = (0.85)$$

Maximum

$$\begin{aligned} \text{Ambient Temperature} &= 85 - 0.3 \cdot 600 \left(\frac{1}{0.85} - 1 \right) \\ &= 53^{\circ}\text{C} \end{aligned}$$

Example 4

Determine the temperature rise of a 150W, VI-200 converter delivering 5V at 132W with a Part #30090 heat sink in 200LFM.

$$\text{Temperature Rise} = \theta_{SA} \cdot P_{OUT} \left(\frac{1}{\eta} - 1 \right)$$

Where:

$$\theta_{SA} = 1.1^{\circ}\text{C/W}$$

$$P_{OUT} = 132\text{W}$$

$$\eta = 81\% = (0.81)$$

$$\begin{aligned} \text{Temperature Rise} &= 1.1 \cdot 132 \left(\frac{1}{0.81} - 1 \right) \\ &= 34^{\circ}\text{C over ambient temperature} \end{aligned}$$

Example 5

Determine the baseplate to coldplate thermal drop for an MI-200 converter delivering 5V at 50W with a thermal pad.

$$\text{Thermal Drop} = \theta_{BS} \cdot P_{OUT} \left(\frac{1}{\eta} - 1 \right)$$

Where:

$$\theta_{BS} = 0.2^{\circ}\text{C/W}$$

$$P_{OUT} = 50\text{W}$$

$$\eta = 81\% = (0.81)$$

$$\begin{aligned} \text{Thermal Drop} &= 0.2 \cdot 50 \left(\frac{1}{0.81} - 1 \right) \\ &= 2.34^{\circ}\text{C} \end{aligned}$$

VI-200 Family Thermal Curves

Note: Use as a design guide only. Verify final design by actual temperature measurement.

Legend: ■—FREE AIR □—200 LFM ◆—400 LFM ◇—600 LFM ▲—800 LFM △—1000 LFM

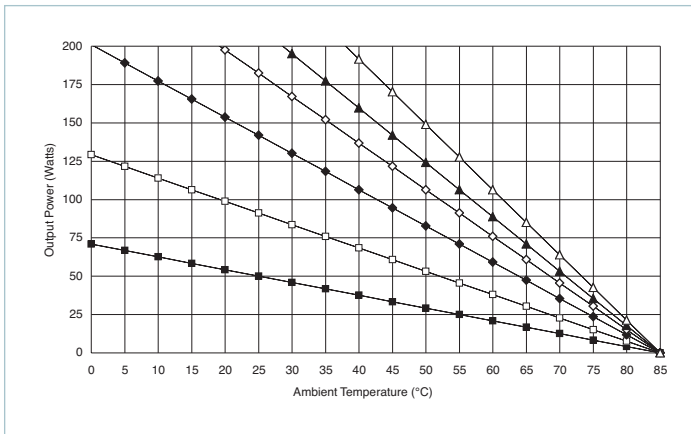

Figure 21.1 — VI-200 family baseplate-to-air (no heat sink) 5V output

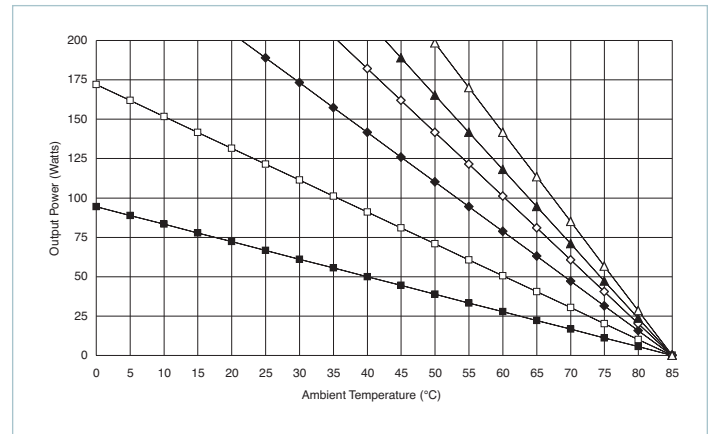

Figure 21.2 — VI-200 family baseplate-to-air (no heat sink) 12 – 48V output

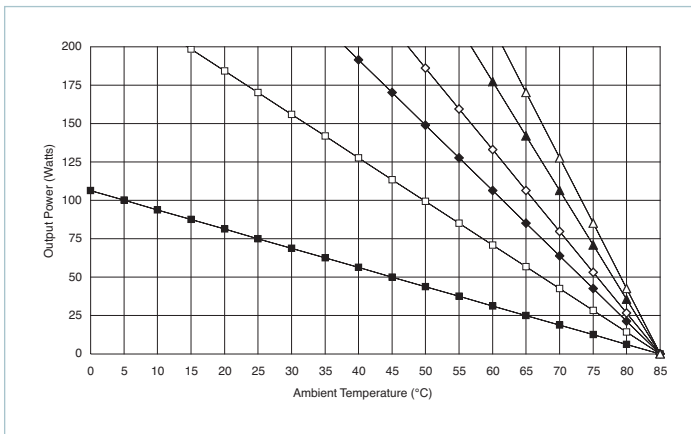

Figure 21.3 — VI-200 family, part #30089 heat sink 5V output

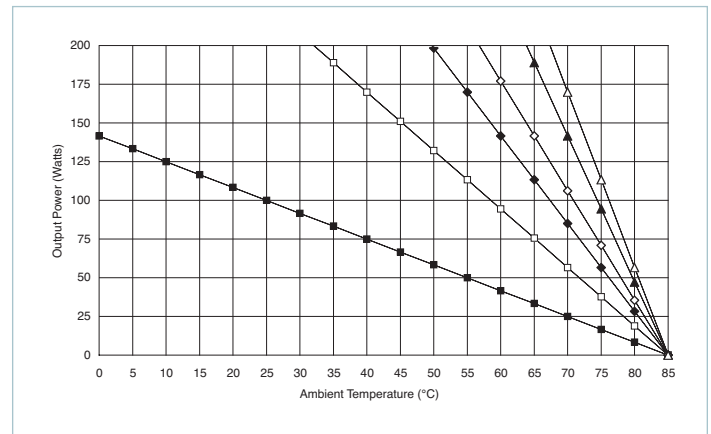

Figure 21.4 — VI-200 family, part #30089 heat sink 12 – 48V output

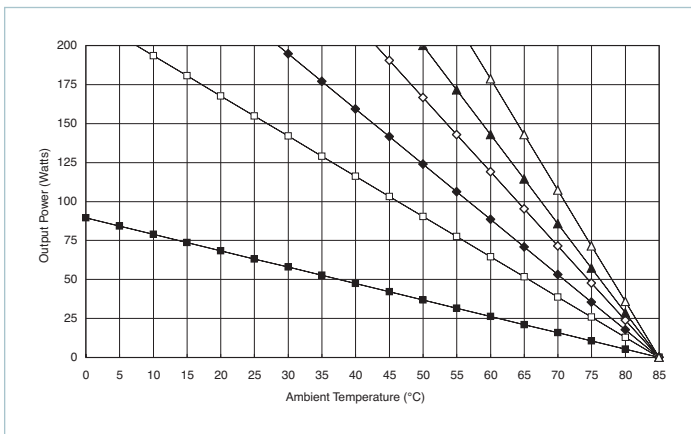

Figure 21.5 — VI-200 family, part #30194 heat sink 5V output

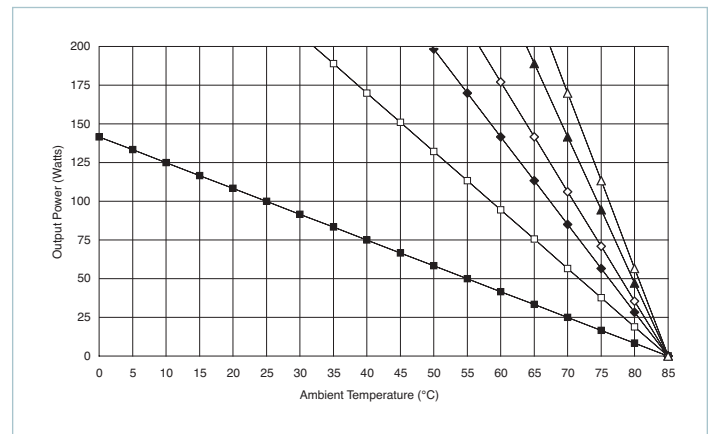

Figure 21.6 — VI-200 family, part #30194 heat sink 12 – 48V output

VI-200 Family Thermal Curves (Cont.)

Note: Use as a design guide only. Verify final design by actual temperature measurement.

Legend: ■— FREE AIR □— 200 LFM ◆— 400 LFM ◇— 600 LFM ▲— 800 LFM △— 1000 LFM

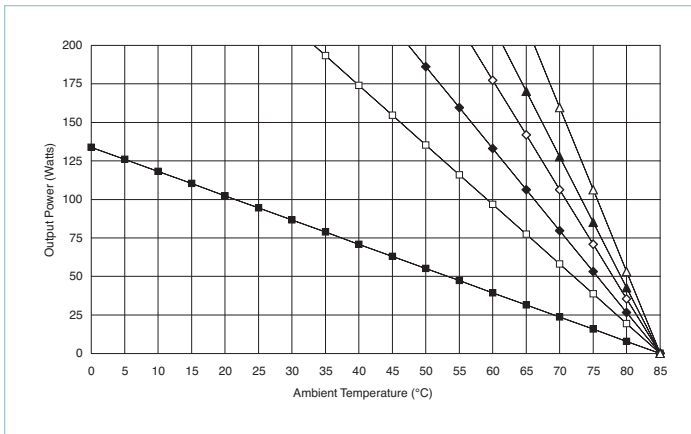

Figure 21.7 — VI-200 family, part #30090 heat sink 5V output

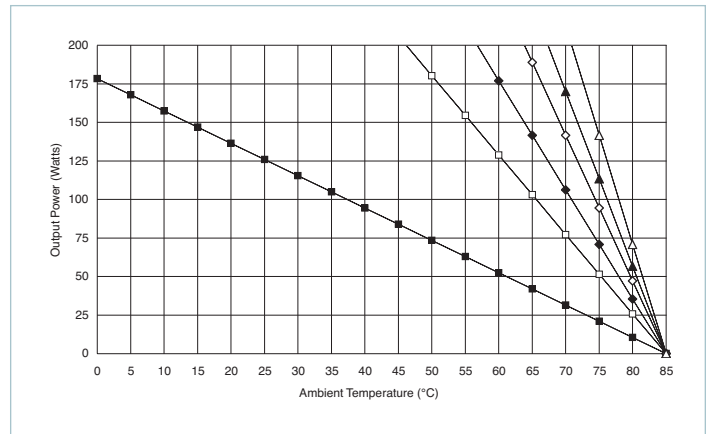

Figure 21.8 — VI-200 family, part #30090 heat sink 12 – 48V output

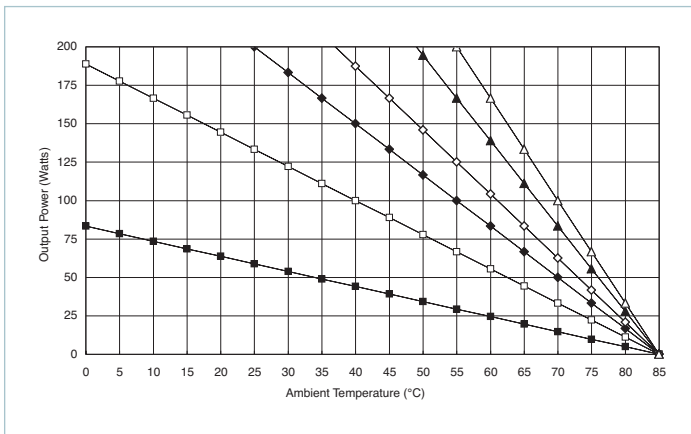

Figure 21.9 — VI-200 family, part #30775 heat sink 5V output

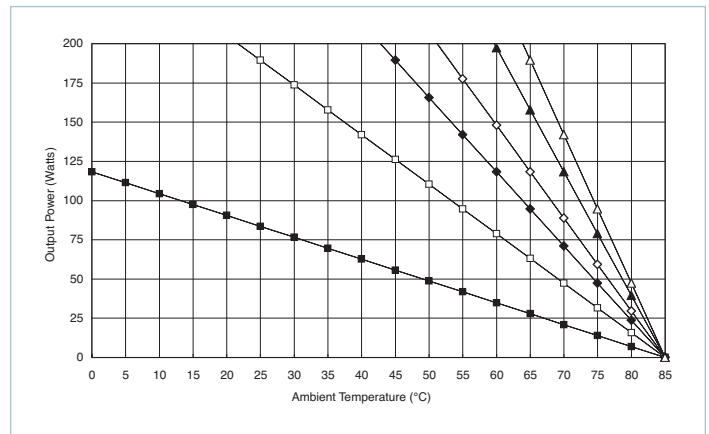

Figure 21.10 — VI-200 family, part #30775 heat sink 12 – 48V output

VI-J00 Family Thermal Curves

Note: Use as a design guide only. Verify final design by actual temperature measurement.

Legend: ■ FREE AIR, H □ FREE AIR, V ◆ 200 LFM ◇ 400 LFM ▲ 600 LFM △ 800 LFM ● 1000 LFM

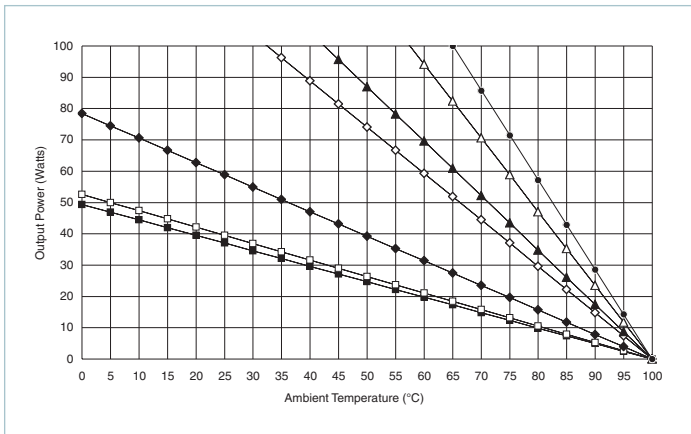

Figure 21.11 — VI-J00 family baseplate-to-air (no heat sink) 5V output

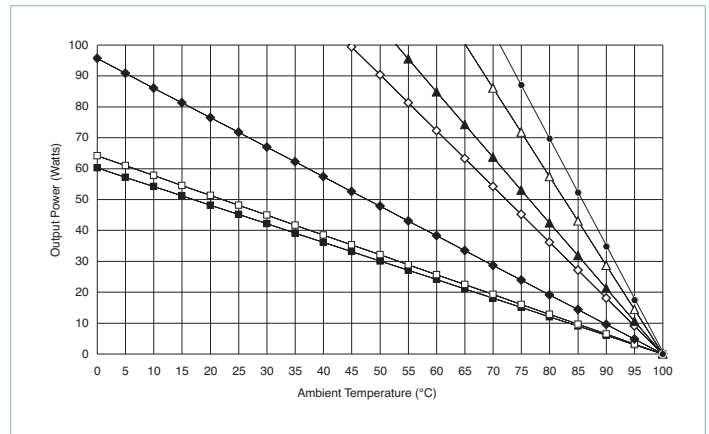

Figure 21.12 — VI-200 family baseplate-to-air (no heat sink) 12 – 48V output

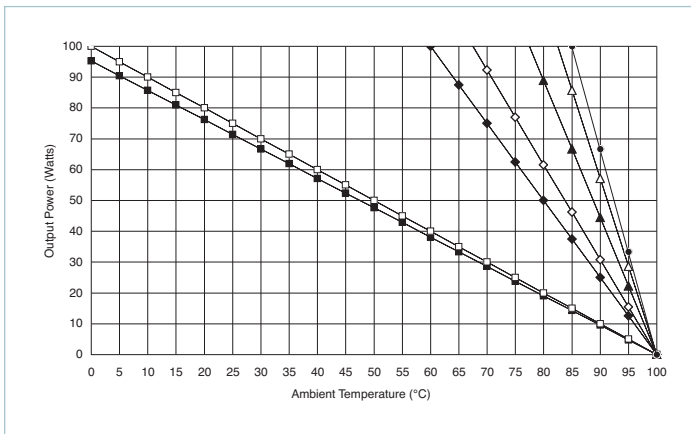

Figure 21.13 — VI-200 family, part #30191 heat sink 5V output

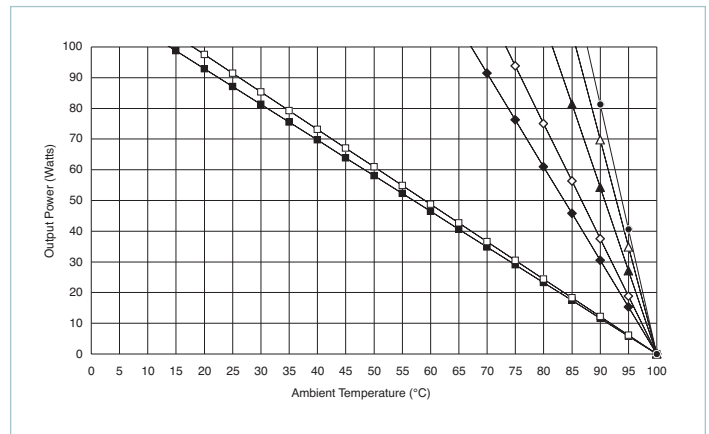

Figure 21.14 — VI-200 family, part #30191 heat sink 12 – 48V output

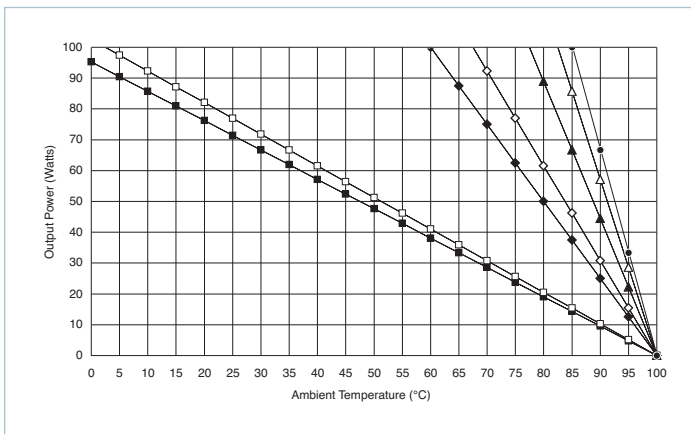

Figure 21.15 — VI-200 family, part #30771 heat sink 5V output

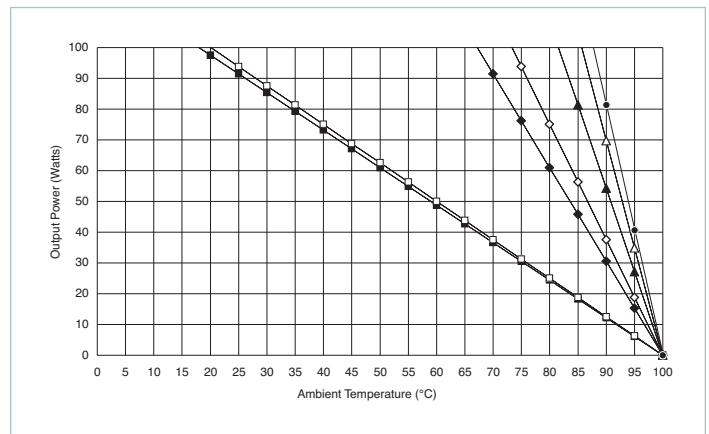

Figure 21.16 — VI-200 family, part #30771 heat sink 12 – 48V output

VI-J00 Family Thermal Curves (Cont.)

Note: Use as a design guide only. Verify final design by actual temperature measurement.

Legend: ■ — FREE AIR, H □ — FREE AIR, V ◆ — 200 LFM ◇ — 400 LFM ▲ — 600 LFM △ — 800 LFM ● — 1000 LFM

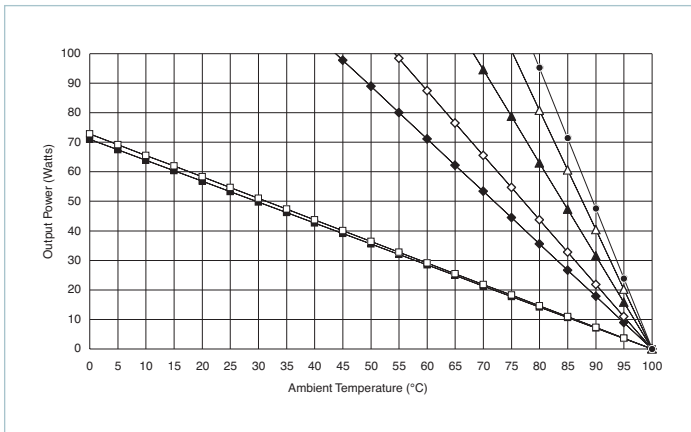

Figure 21.17 — VI-200 family, part #30140 heat sink
5V output

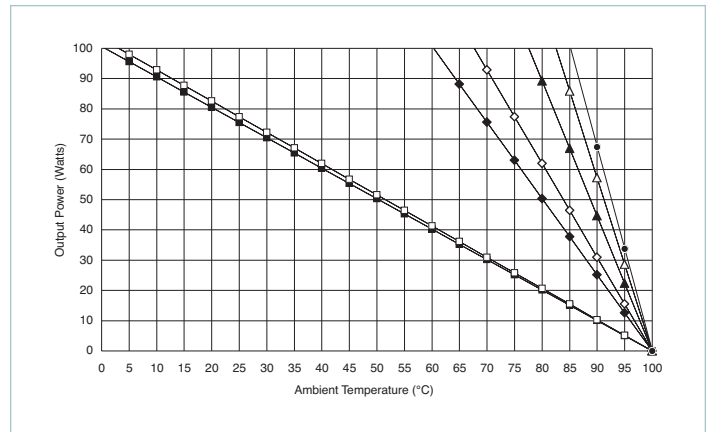

Figure 21.18 — VI-200 family, part #30140 heat sink
12 – 48V output

FinMod™ VI-200 Family Thermal Curves

Note: Use as a design guide only. Verify final design by actual temperature measurement.

Legend: ■— FREE AIR □— 200 LFM ◆— 400 LFM ◇— 600 LFM ▲— 800 LFM △— 1000 LFM

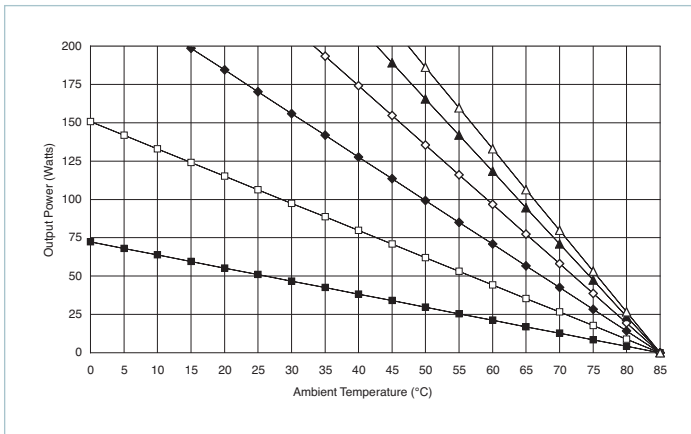

Figure 21.19 — FinMod VI-200 family F1/F3 configuration 5V output

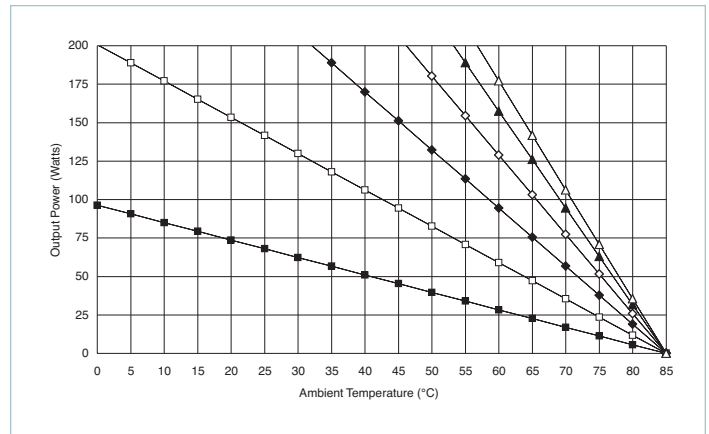

Figure 21.20 — FinMod VI-200 family F1/F3 configuration 12 – 48V output

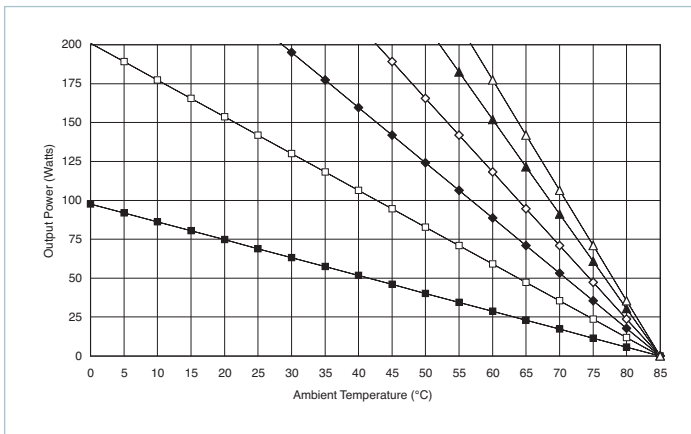

Figure 21.21 — FinMod VI-200 family F2/F4 configuration 5V output

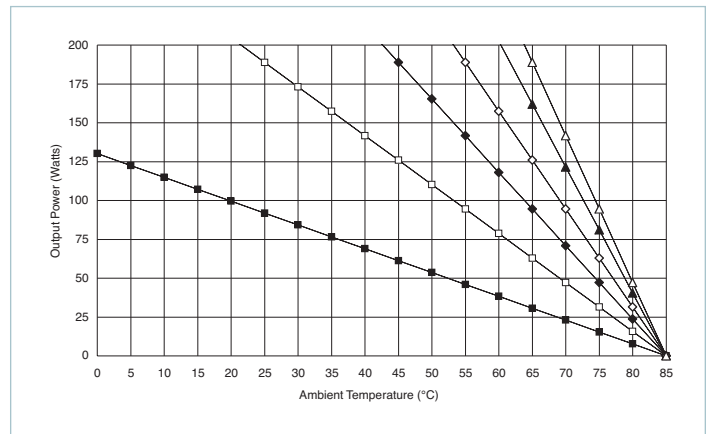

Figure 21.22 — FinMod VI-200 family F2/F4 configuration 12 – 48V output

FinMod™ VI-J00 Family Thermal Curves

Note: Use as a design guide only. Verify final design by actual temperature measurement.

Legend: ■— FREE AIR, H □— FREE AIR, V ◆— 200 LFM ◇— 400 LFM ▲— 600 LFM △— 800 LFM ●— 1000 LFM

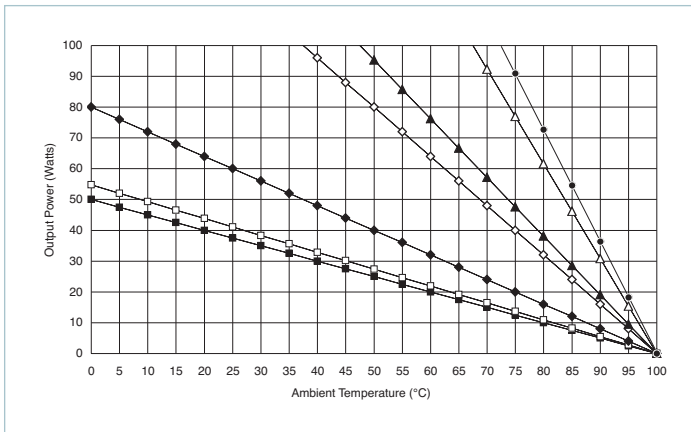

Figure 21.23 — FinMod VI-J00 family F1/F3 configuration 5V output

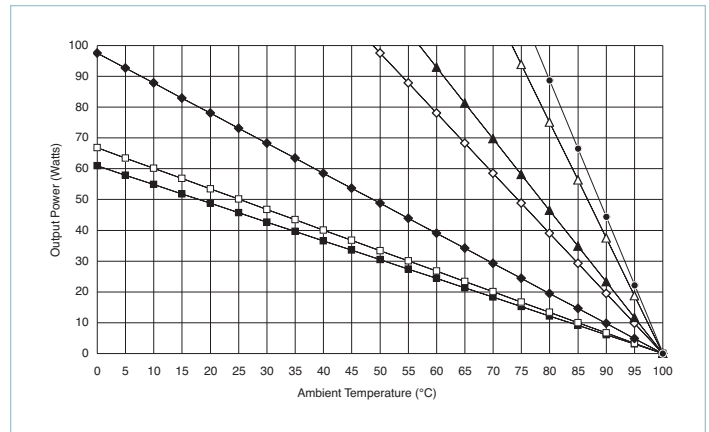

Figure 21.24 — FinMod VI-J00 family F1/F3 configuration 12 – 48V output

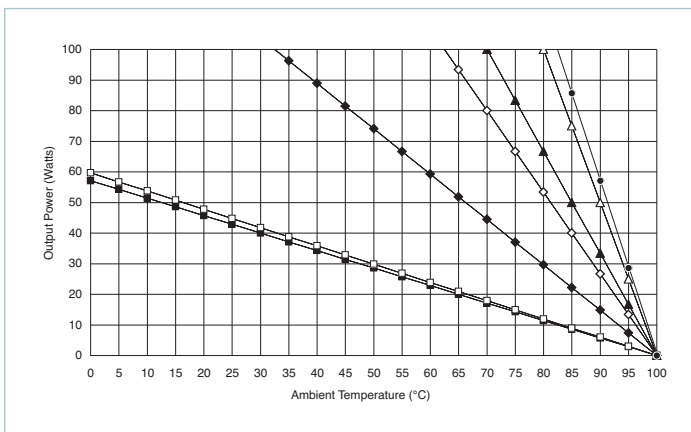

Figure 21.25 — FinMod VI-J00 family F2/F4 configuration 5V output

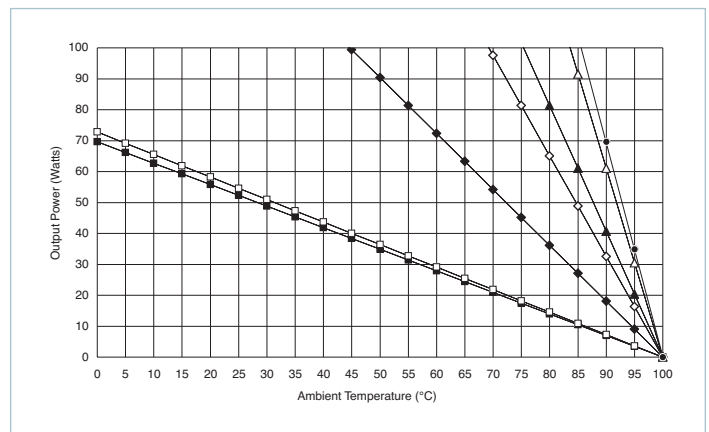

Figure 21.26 — FinMod VI-J00 family F2/F4 configuration 12 – 48V output

SlimMod™ VI-200 Family Thermal Curves

Note: Use as a design guide only. Verify final design by actual temperature measurement.

Legend: ■— FREE AIR □— 200 LFM ◆— 400 LFM ◇— 600 LFM ▲— 800 LFM △— 1000 LFM

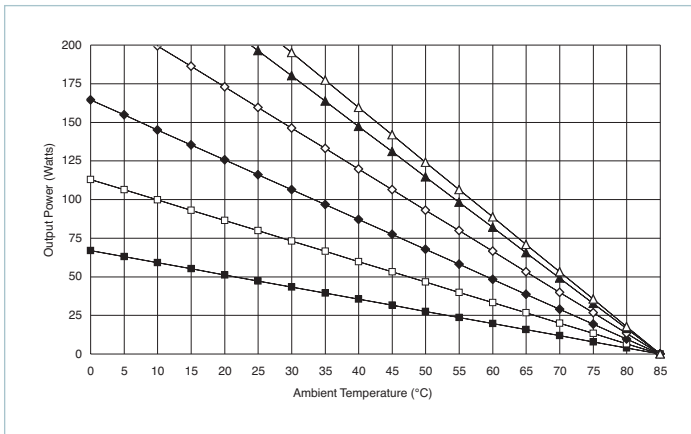

Figure 21.27 — SlimMod VI-200 family 5V output

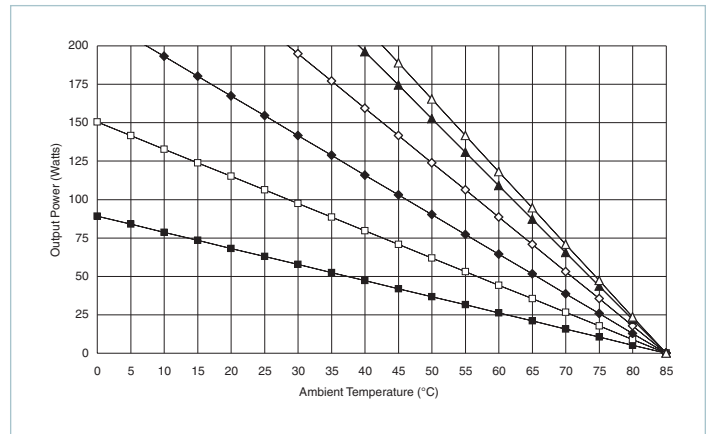

Figure 21.28 — SlimMod VI-200 family 12 – 48V output

SlimMod™ VI-J00 Family Thermal Curves

Note: Use as a design guide only. Verify final design by actual temperature measurement.

Legend: ■— FREE AIR, H □— FREE AIR, V ◆— 200 LFM ◇— 400 LFM ▲— 600 LFM △— 800 LFM ●— 1000 LFM

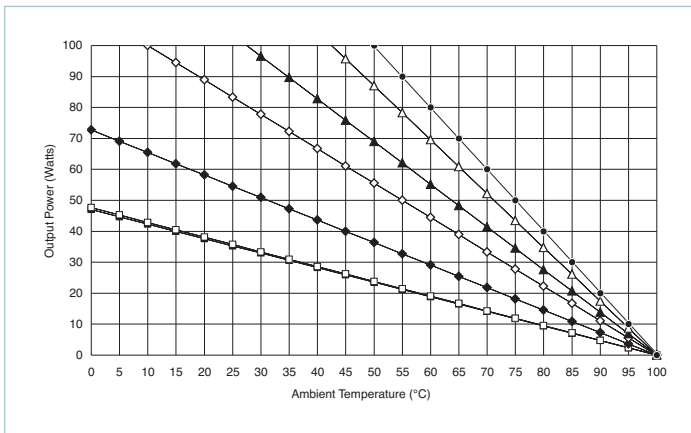

Figure 21.29 — SlimMod VI-J00 family 5V output

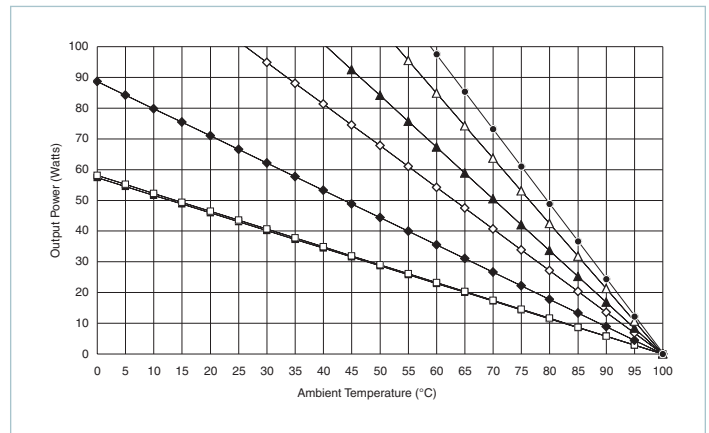

Figure 21.30 — SlimMod VI-J00 family 12 – 48V output

ComPAC™ Family Thermal Curves

Note: Use as a design guide only. Verify final design by actual temperature measurement.

Legend: ■ FREE AIR, H □ FREE AIR, V ◆ 200 LFM ◇ 400 LFM ▲ 600 LFM △ 800 LFM ● 1000 LFM

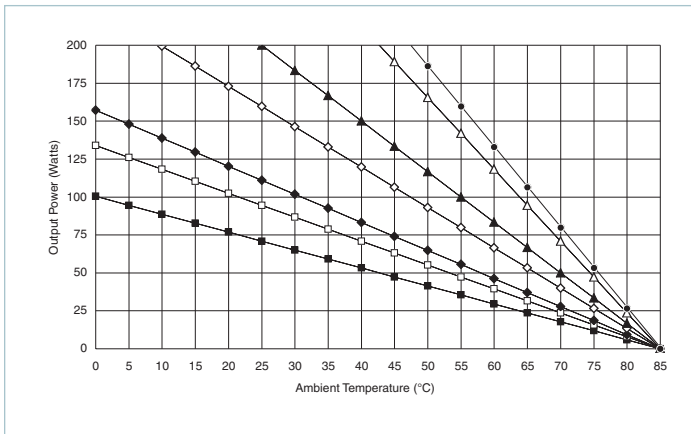

Figure 21.31 — 1-up ComPAC
5V output

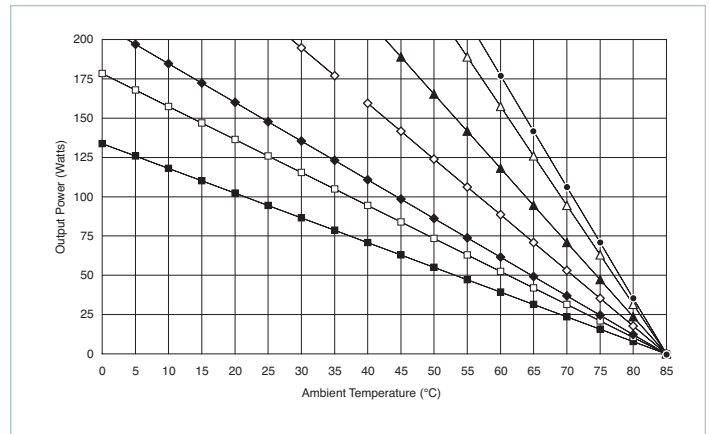

Figure 21.32 — 1-up ComPAC
12 – 48V output

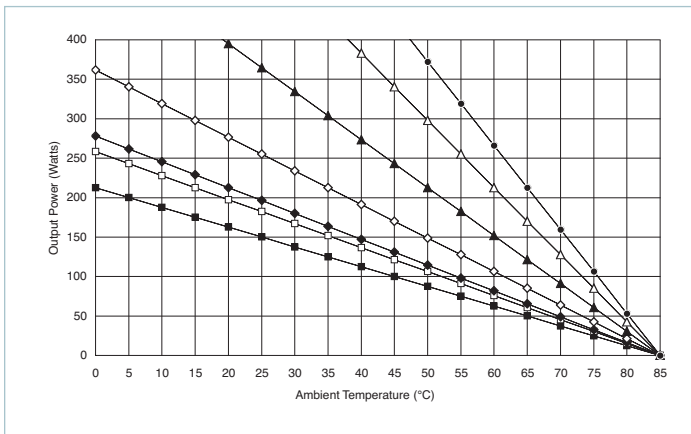

Figure 21.33 — 2-up ComPAC
5V output

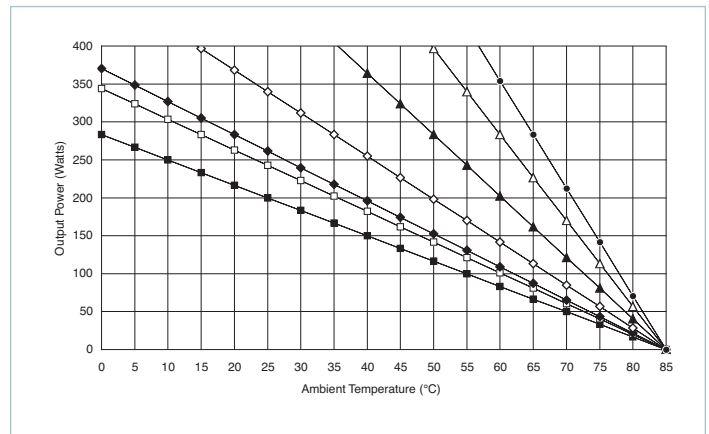

Figure 21.34 — 2-up ComPAC
12 – 48V output

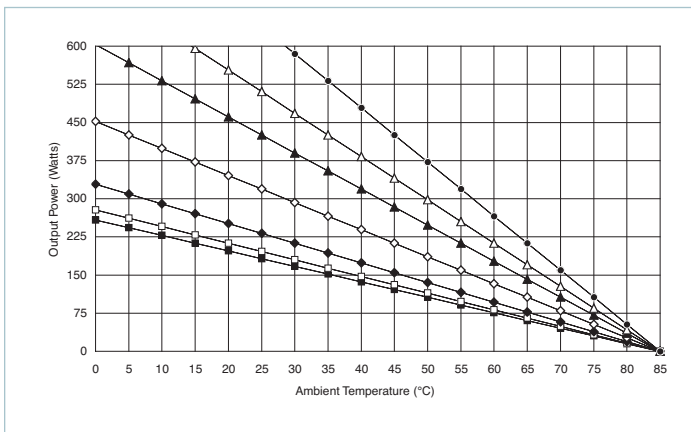

Figure 21.35 — 3-up ComPAC
5V output

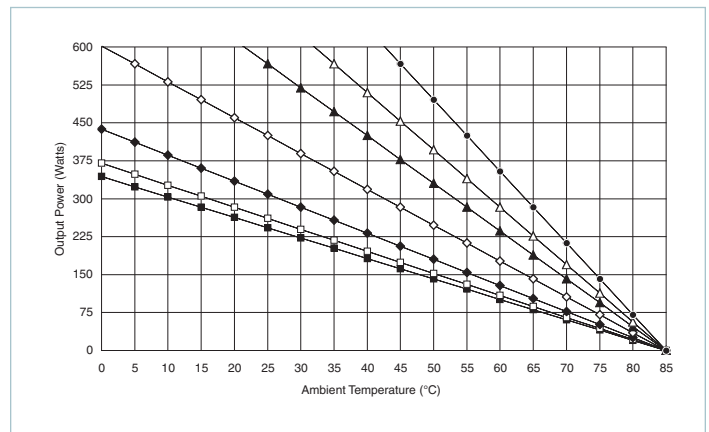

Figure 21.36 — 3-up ComPAC
12 – 48V output

FlatPAC™ Family Thermal Curves

Note: Use as a design guide only. Verify final design by actual temperature measurement.

Legend: ■ FREE AIR, H □ FREE AIR, V ◆ 200 LFM ◇ 400 LFM ▲ 600 LFM △ 800 LFM ● 1000 LFM

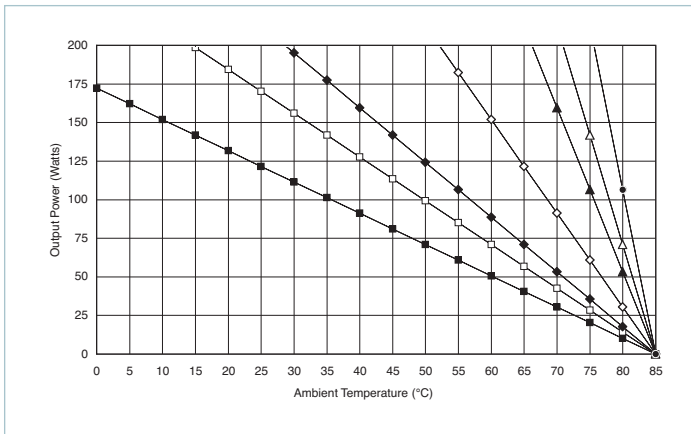

Figure 21.37 — 1-up FlatPAC
5V output

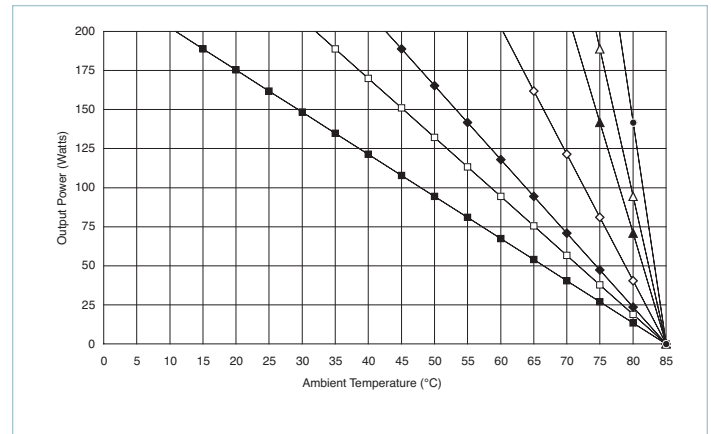

Figure 21.38 — 1-up FlatPAC
12 – 48V output

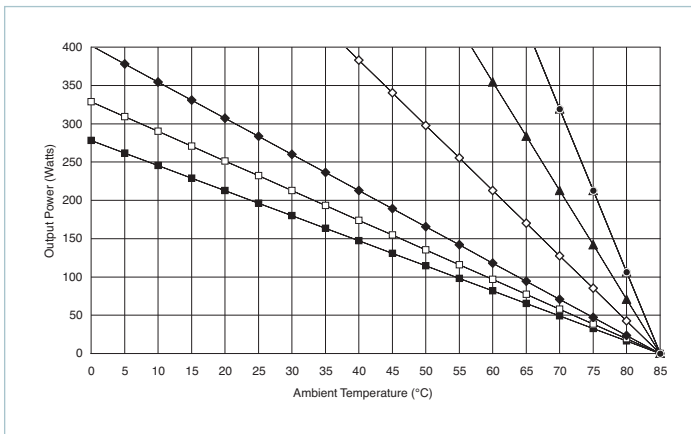

Figure 21.39 — 2-up FlatPAC
5V output

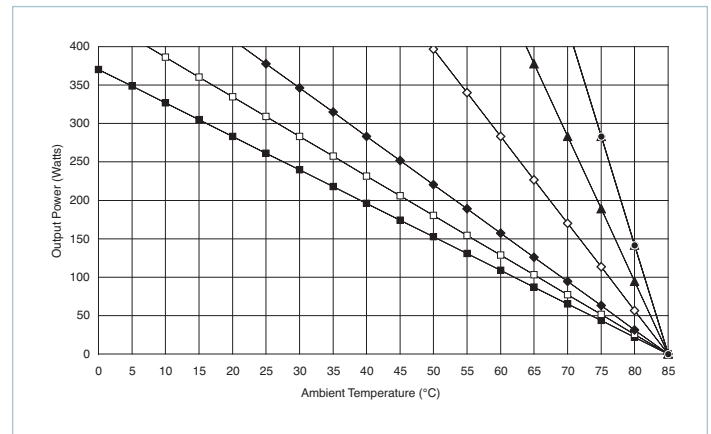

Figure 21.40 — 2-up FlatPAC
12 – 48V output

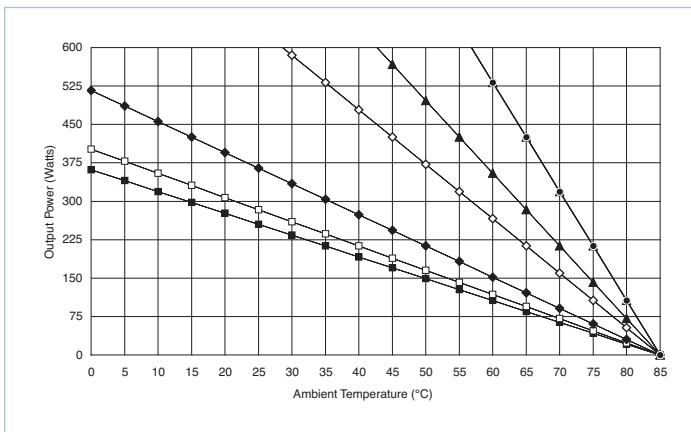

Figure 21.41 — 3-up FlatPAC
5V output

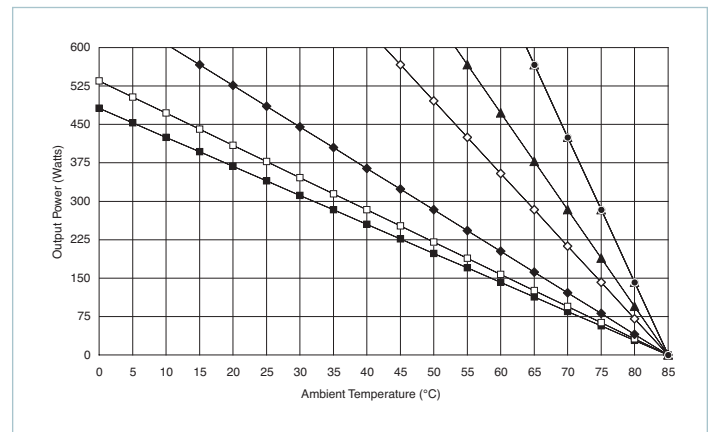

Figure 21.42 — 3-up FlatPAC
12 – 48V output

PFC FlatPAC™ Family Thermal Curves

Note: Use as a design guide only. Verify final design by actual temperature measurement.

Legend: ■ FREE AIR □ 200 LFM ◆ 400 LFM ◇ 600 LFM ▲ 800 LFM △ 1000 LFM

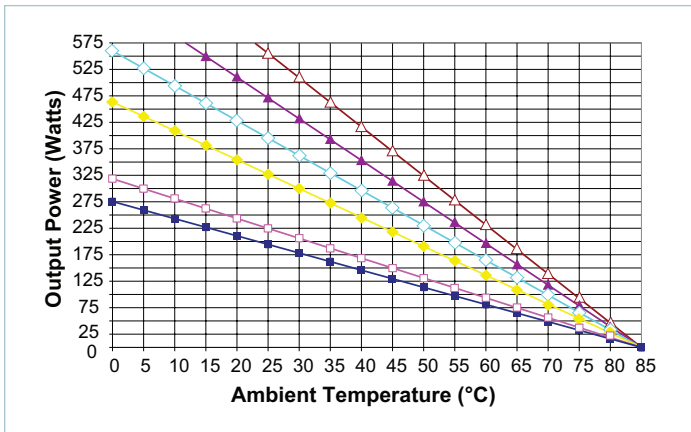

Figure 21.43 — Output power de-rating vs. temperature, $V_{OUT} \geq 12V$

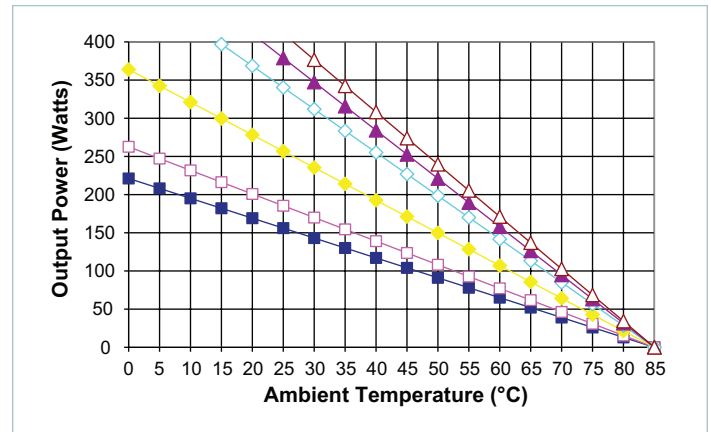

Figure 21.44 — Output power de-rating vs. temperature, $V_{OUT} = 5V$

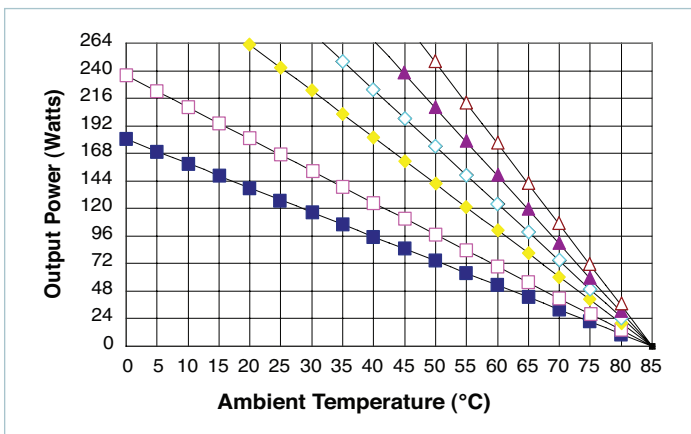

Figure 21.45 — Output power de-rating vs. temperature, $V_{OUT} = 3.3V$

Overview

The following chapters contain soldering information for the following Vicor product families: Maxi, Mini, Micro; VE-200, VE-J00; VI Brick® and similar package filters and front-ends. This document is intended to provide guidance for making high-quality solder connections of RoHS-compliant Vicor power modules to printed circuit boards. This application note applies to lead-free soldering of Vicor RoHS-compliant modules. The following provides an outline for appropriate soldering procedures and the evaluation of solder joints to ensure an optimal connection to the power module. Common soldering defects will be examined and direction will be provided for detecting and handling them. Vicor manufacturing facilities use the IPC-A-610 standards for establishing quality solder joints. It is recommended that manufacturing processes using Vicor modules refer to these same standards, which can be found, along with supporting documentation, at www.ipc.org.

Analysis of a Good Solder Joint

The IPC-A-610 standard requires that solder fill at least 75% of the barrel to ensure a solid connection. Ideally, all connections should have a 100% fill. To accomplish this, the solder applied to both the barrel and the pin must exhibit a process known as wetting. Wetting occurs when liquid solder on a surface is heated to the point that it loses a significant amount of latent surface tension and evenly coats the surface via capillary action (both cohesion and adhesion).

During the soldering process wetting can be identified by an even coating of solder on the barrel and pin. In addition, coating the surface of barrel and pin, the solder will gather at the intersection of the two and produce a trailing fillet along each surface. Once wetting has occurred, then upon solidification it will bond appropriately to both components, producing a quality connection.

Figure 22.1 shows a side profile of a good solder joint with a power module. Notice that the solder forms a concave meniscus between pin and barrel. This is an example of a properly formed fillet and is evidence of good wetting during the soldering process. The joint between solder and pin as well as solder and pad should always exhibit a feathered edge. In Figure 22.1 it can also be seen that the solder covers a good deal of the surface area of both the pin and the pad. This is also evidence of good wetting. (Notice also that the solder joint is dull compared to leaded processing). This is evidence of good immobilization of the joint during cooling as well as good cleaning of the board prior to soldering. All soldering connections should exhibit similar characteristics regardless of whether they are soldered by hand, by fountain, or by wave.

In examining a solder joint, be sure that there is no solder connecting one pad to another. This is known as a solder bridge and will be discussed later.

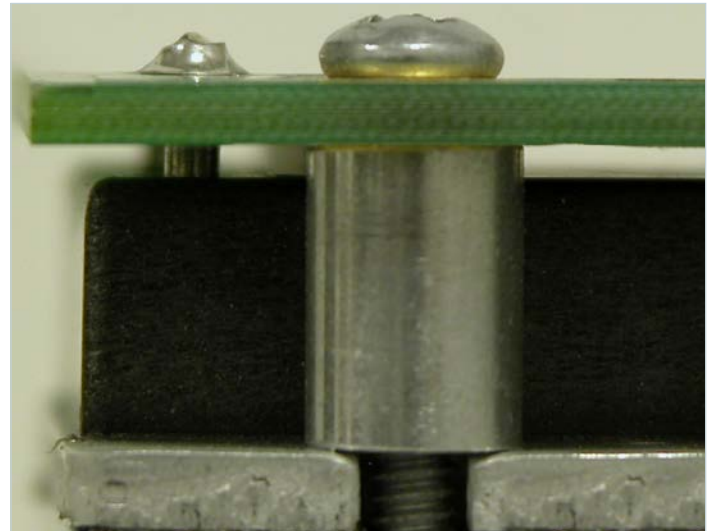

Figure 22.1 — Side profile of Maxi or Mini module's RoHS solder joint

Soldering Procedures

Hand Soldering. Before soldering, make sure that the PCB is clean and free of debris, chemical residue or liquid. It is not recommended that additional flux other than what is contained in the solder be used during soldering because it potentially leaves a residue that cannot be removed without potentially damaging or compromising the power module. Also, the presence of these residues on the modules may cause harm or improper operation.

The pins on Vicor modules are optimized to provide a low-resistance electrical connection. The final mounting scheme for any module should be designed to minimize any potential mechanical stress on the pins and solder joints. Modules with heat sinks or modules used in systems that are subject to shock or vibration should use standoffs to minimize stress on the pins. It is not recommended that discrete wires or connectors be soldered directly onto a module.

Also necessary for a good solder connection is pin protrusion from the PCB. It is not possible to create a good solder joint without some protrusion of module pins from the PCB. If the PCB is too thick to allow good pin protrusion, consider using Vicor module accessories such as sockets to allow proper mounting. Before soldering, the module should be mechanically affixed or immobilized with

respect to the PCB to ensure no movement during the soldering process. The standoffs can be used for this process. Vicor power modules contain two types of pins: power pins (which deliver the power to the load and are typically sized according to the rated output current) and signal pins (which typically carry very little current and are of a uniform size across a given product family). The larger the pin, the more soldering time required to form an adequate connection. In addition to the sizing of the pin, the time required to create a robust connection will vary depending on several parameters:

1. **PCB Thickness.** The thicker the printed circuit board, the more heat it is able to dissipate, and will require more soldering time.
2. **Copper Trace Area.** Power pins require large copper traces to minimize resistive power losses in carrying the power to the load. Since the copper tends to conduct heat well, the actual sizes of these copper traces directly affect the amount of time necessary to heat the PCB socket.
3. **Copper Trace Thickness.** As above, the thickness of the copper trace is a function of output current of the module, and has a direct impact on the amount of soldering time. Typically, PCB copper thickness is specified in terms of weight per square foot, typically 2oz or 3oz copper for current-carrying planes.
4. **Soldering Iron Power.** A higher power soldering iron can source more heat and thus take less time to heat a PCB trace. As a soldering iron is heating a point on the board, everything that is adjacent to this point is being heated as well, including the Vicor power module. A large copper trace, because it conducts heat very well, will exhibit less of a thermal gradient, and thus a low-power soldering iron will have to heat the whole trace to a higher temperature before the area close to the iron is hot enough to flow solder. Because the trace and board are both dissipating and conducting thermal energy, some irons may not have enough power to heat a trace to the temperature that will allow proper soldering.
5. **Tip Temperature.** Typical SAC-type solder melts at 419 – 491°F [215 – 225°C]. Pb-free soldering requires a tip temperature of about 800°F. A higher tip temperature will bring the barrel and pin above the melting point of solder faster. However, a higher tip temperature may cause damage to the pad, printed circuit board, or module pin.
6. **Type of Lead-free Solder.** The actual melting point of the solder varies depending on the type of solder used and affects the necessary temperature of the pad and pin for flow. Vicor recommends SAC305 SnAgCu solder for use on Vicor power modules.
7. **Tip Size.** A larger tip will be able to heat a larger surface area, thus lowering soldering time.

Since there are so many factors that influence soldering time, listing actual times is difficult. In general, it is recommended that the joint be examined post-process to insure a quality soldering joint. If necessary, different parameters can then be varied in order to ensure a solid process. The soldering times listed in Table 22.1 can be used as a guideline for establishing more application and process specific parameters. Below are some recommendations for general practice:

1. Do **not** run tip temperature above 810°F [430°C]. This will greatly increase the risk of damaging the pads, traces, printed circuit board, or Vicor power module. Check with the printed circuit board manufacturer that the boards are RoHS capable and for any additional recommendations in regard to temperature.
2. Apply the soldering iron to one side of the pin and pad and apply the solder to the other, allowing the heat from the pin and pad to melt the solder. Do not apply solder to the soldering iron and subsequently attempt to transfer it to the pad and pin. Melting the solder by applying it directly to the soldering iron does not guarantee adequate wetting on the joint and is not considered good technique.
3. Do **not** apply excessive pressure with the soldering iron to the printed circuit board, barrel, or pad. This could result in breaking a trace, dislodging a barrel, or damaging the PCB, which becomes noticeably softer when heated.
4. Do **not** apply the soldering iron to a connection for an extended period of time or damage to the module could result. If the soldering times exceed the upper limit listed in Table 22.1, consider using a larger tip or a higher power soldering iron.
5. Make sure PCB pads and holes are clean before to soldering.
6. Solders with no-clean flux may be used to facilitate soldering.
7. Keep the tip of the soldering iron clean and free from resin. Apply a small amount of solder directly to the tip of the iron. This process is known as tinning.

8. Be careful not to jar the module or PCB while the solder is cooling. This could result in a cold solder joint, a void in the barrel or a cracked joint.
9. If it is necessary to re-solder a joint, remove all existing solder from the pad and pin before reapplying solder.
10. Use of a soldering gun is **not** recommended for soldering Vicor modules.
11. It is **not** recommended that Maxi / Mini / Micro module pins be trimmed under any circumstances.

As a procedural benchmark, given an 800°F (427°C) temperature on a 60W iron with a 3mm tip, approximate times to solder a Vicor power module to a 0.062in [1,5mm] thick PCB board with an appropriately sized copper trace would be in the range of Table 22.1.

Converter Family	Pin Type	Soldering Time (Range)
VE-200 / VE-J00	Signal	3 – 5 seconds
VE-200	Power	5 – 8 seconds
VE-J00	Power	4 – 7 seconds
Maxi / Mini / Micro	Singal	3 – 5 seconds
Maxi	Power	5 – 8 seconds
Mini	Power	4 – 7 seconds
Micro	Power	3 – 5 seconds
VI Brick	Input & Signal	3 – 5 seconds
VI Brick	Power	4 – 7 seconds

Table 22.1 — Recommended pin soldering times for RoHS family modules

Again, please note that soldering for significantly longer periods of time than those listed above could result in damage to the module. Table 22.1 should not be used without verifying that the times will produce a quality soldering joint as defined in the previous sections.

Wave Soldering. Vicor modules achieve an adequate solder connection on a wave-soldering machine with conveyor speeds from three to seven feet per minute. As with hand soldering, times and parameters vary with the properties of the PCB and copper traces. As a standard benchmark, the parameters below may be used. As with hand-soldered boards, the results should be examined to ensure a quality soldering joint and a sound process.

Wave Soldering Profile.

1. Bottom-side preheaters: Zone 1: 350°F [177°C], Zone 2: 300°F [149°C], Zone 3: 675°F [357°C]
2. Top-side preheaters: 220 – 235°F [104 – 113°C]
3. Wave temperature: 510°F [266°C]
4. Wave type: 4.25in [107,95mm] standard laminar wave

Preheating of the PCB is generally required for wave soldering operations to ensure adequate wetting of the solder to the PCB. The recommended temperature for PCB top side is 203 – 248°F [95 – 120°C] prior to the molten wave. Thick, multilayer PCBs should be heated toward the upper limit of this range, while simple two-layer PCBs should be heated to the lower limit. These parameters are consistent with generally accepted requirements for circuit-card assembly. The power module is often much more massive than other components mounted to the PCB. During wave solder preheating, the pins will dissipate much of their absorbed heat within the module; therefore, adjustments to preheaters alone will not improve module soldering significantly. A more effective way to improve the soldering of the module is to lower the conveyor speed and increase the dwell time in the molten wave. Approximately 5 seconds of exposure to the molten wave is required to achieve an acceptable solder joint for a Maxi / Mini / Micro power module. The VE-200 / VE-J00 / VE-HAM and VI Brick® modules should solder in approximately 4 seconds of molten wave exposure.

Post Solder Cleaning. Vicor modules are not hermetically sealed and must not be exposed to liquid, including but not limited to cleaning solvents, aqueous washing solutions or pressurized sprays. Cleaning the backside of the PCB is acceptable provided no solvent contacts the body of the module.

When soldering, it is recommended that no-clean flux solder be used, as this will ensure that potentially corrosive mobile ions will not remain on, around or under the module following the soldering process.

If the application requires the PCB to be subject to an aqueous wash after soldering, then it is recommended that Vicor module accessories such as through-hole or surface-mount sockets be used. These sockets should be mounted to the PCB, and the modules subsequently inserted following the aqueous washing sequence.

De-soldering Vicor Modules. Vicor modules should not be re-used after desoldering for the following reasons:

1. Most de-soldering procedures introduce damaging mechanical and thermal stresses to the module.
2. Devices or processes that may be capable of desoldering a Vicor module from a printed-circuit board without causing damage have not been qualified for use with Vicor modules.

For applications that require removal of a module with the intent of reuse, use Vicor socketing systems.

Index of Common Soldering Defects

1. **Solder Bridge.** A short circuit between two electrically inadvertently forming a “bridge” or connection between the two points.

Recommended Solution. Use a smaller soldering tip, or hold the tip at a different angle when soldering, so as to contact only one pad at a time.

2. **Cold Solder.** An incomplete or poor connection caused by either the barrel or the pin not being heated to the flow temperature of solder. A cold solder joint will typically exhibit a convex meniscus with possibly a dark spot around the barrel or pad. Also, a cold solder joint will not be shiny, but will typically have a “dirty” appearance.

CAUTION: A cold solder joint is not necessarily an open connection electrically, and cannot be diagnosed by a simple continuity check. A cold solder joint is frequently an electrically intermittent connection and is best diagnosed by way of visual inspection. A cold solder joint will likely become electrically open following a period of temperature cycling.

Recommended Solution. Increase soldering iron temperature, soldering time, or use a soldering iron with a higher output wattage if hand soldering. If wave soldering, lower conveyor speed or increase preheat temperature.

3. **PC Board Damage.** An intermittent or poor connection caused by damage to a trace, pad, or barrel. A damaged pad is best identified by a burn mark on the PCB or a trace pad that moves when prodded with a mechanical object.

Recommended Solution. Lower the soldering iron temperature or the soldering time. If damage persists, use a lower power iron or consult with the manufacturer of the PCB for recommended soldering guidelines.

4. **De-wetting.** The solder initially appears to wet but then pulls back to expose the pad surface. More common in wave soldering.

Recommended Solution. Make sure the PCB is clean prior to soldering.

5. **Dry Joint.** The solder has a dull gray appearance as opposed to a bright silver surface. The solder joint may have a mottled look as well, with jagged ridges. It is caused by the solder joint moving before it has completely cooled.

Recommended Solution. Immobilize the module with respect to the PCB to ensure that the solder joint cools properly.

6. **Icicles.** Jagged or conical extensions from solder fillet. These are caused by soldering with the temperature too low, or soldering to a highly heat-absorbent surface.

Recommended Solution. Increase the soldering temperature, but not outside the recommended limits. If necessary, use a higher power soldering iron.

7. **Pinholes.** Small or large holes in surface of solder joint, most commonly occurring in wave-solder systems.

Recommended Solution. Increase preheat or topside heater temperature, but not outside the recommended limits.

References
<p><u>Organizations</u></p> <p>www.ipc.org</p> <p><u>Commercial</u></p> <p>www.aimsolder.com</p> <p>www.alphaassembly.com</p> <p>www.kester.com</p> <p>www.multicore-association.org</p>

Maxi / Mini / Micro Standoff Kits for Solder-Mounted Modules							
Board Thickness Nominal (Min – Max)	Mounting Options		Slotted Baseplate		Through-Hole Baseplate		Threaded Baseplate
	Mounting Style	Pin Style	Through-Hole Heat Sink	Threaded Heat Sink	Through-Hole Heat Sink	Threaded Heat Sink	Through-Hole Heat Sink
0.062in (0.055 – 0.071in) 1,5mm (1,4 – 1,8mm)	Inboard	F	Kit-18150	Kit-18151	Kit-18146	Kit-18147	Kit-18146
			Bag-19126	Bag-19127	Bag-19122	Bag-19123	Bag-19122
	Onboard	G	Kit-18156	Kit-18157	Kit-18150	Kit-18152	Kit-18150
			Bag-19132	Bag-19133	Bag-19126	Bag-19128	Bag-19126
0.093in (0.084in/0.104in) 2,4mm (2,1 – 2,6mm)	Inboard	G	Kit-18150	Kit-18151	Kit-18146	Kit-18147	Kit-18146
			Bag-19126	Bag-19127	Bag-19122	Bag-19123	Bag-19122

Kits include six (6) standoffs and screws. Mini and Micro modules require a minimum of four (4) standoffs. Bags contain 100 standoffs only (#4-40 screws required).

Table 22.2 — Standoff kits for solder mounted modules

VI Brick® Standoff Kits		
Standoffs	Description	Part No.
F-F Standoff 0.287in long	12pc kit for 0.125in PCB (includes M3 x 5mm and M3 x 6mm screws)	34717
	12pc kit for 0.062in PCB (includes M3 x 5mm screws)	34718
	100pc bag	34709
M-F Standoff 0.287in long	12pc Kit (includes M3 x 6 mm screws)	34719
	100pc bag	34710

Bags contain 100 standoffs only (M3 screws required).

Table 13.3 — VI Brick® Standoff Kits

Overview

The following chapters contain soldering information for the following Vicor product families; Maxi, Mini, Micro; VI-200, VI-J00; VI Brick® and similar package filters and front ends. This document is intended to provide guidance in utilizing soldering practices to make high-quality connections of Vicor power modules to printed circuit boards. Some care will be taken to outline appropriate soldering procedures as well as the evaluation of solder joints in a manner that enables the customer to ensure that the end application has an optimal connection to the power module. Common soldering defects will be examined and direction will be provided for detecting and handling the common defects.

Vicor manufacturing facilities use the IPC-A-610C standards as a means of establishing quality solder joints. It is recommended that manufacturing processes using Vicor modules refer to these same standards, which can be found, along with supporting documentation, at www.ipc.org.

Analysis of a Good Solder Joint

The IPC-A-610C standard requires that solder fill at least 75% of the barrel in order to ensure a solid connection. Ideally, all connections should have a 100% fill. In order to accomplish this, the solder applied to both the barrel and the pin must exhibit a process known as wetting. Wetting occurs when liquid solder on a surface is heated to the point that it loses a significant amount of latent surface tension and evenly coats the surface via capillary action (both cohesion and adhesion).

During the soldering process wetting can be identified by an even coating of solder on the barrel and pin. In addition to coating the surface of barrel and pin, the solder will gather at the intersection of the two and produce a trailing fillet along each surface. Once wetting has occurred, then upon solidification it will bond appropriately to both components, producing a quality connection. Figure 23.1 shows a side profile of a good solder joint with a Mini power module. Notice that for both examples the solder forms a concave meniscus between pin and barrel. This is an example of a properly formed fillet and is evidence of good wetting during the soldering process. The joint between solder and pin as well as solder and pad should always exhibit a feathered edge. In Figure 23.1 it can also be seen that the solder covers a good deal of the surface area of both the pin and the pad. This is also evidence of good wetting. Notice also that the solder joint has a smooth surface with a silver color. This is evidence of good immobilization of the joint during cooling as well as good cleaning of the board prior to soldering. All soldering connections should exhibit similar characteristics regardless of whether they are soldered by hand or wave soldered.



Figure 23.1 — Side profile of a Mini module solder joint



Figure 23.2 — Maxi / Mini output power pin and Sense pin

Figure 23.2 is a top view of the signal and power pin of a Maxi or Mini module properly soldered to a printed circuit board. Notice that both the joint and the area around the joint are clean and free from resin and solder residue. Also the pad and printed circuit board adjacent to the barrel are not burnt or discolored and are solidly attached to each other. In examining a solder joint, be sure that there is no solder connecting one pad to another. This is known as a solder bridge and will be discussed further along with other potential soldering defects.

Soldering Procedures

Hand Soldering. Before soldering, make sure that the PCB is clean and free of debris, chemical residue or liquid. It is not recommended that additional flux other than what is contained in the solder be used during soldering as it potentially leaves a residue that cannot be removed without potentially damaging or compromising the power module. Also, the presence of these residues themselves on the modules may cause harm or improper operation. The pins on Vicor modules are optimized in design for providing a low-resistance electrical connection. The final mounting scheme for any module should be designed so as to minimize any potential mechanical stress on the pins and solder joints. Modules with heat sinks or modules used in systems that are subject to shock or vibration should use standoffs to minimize stress on the pins. Tin / lead pins are specifically designed for soldering applications while gold pin options are specified for socketed applications (see SurfMate or InMate mounting systems). It is not recommended that discrete wires or connectors be soldered directly onto a module.

Also necessary for a good solder connection is pin protrusion from the PCB. It is not possible to create a good solder joint without some protrusion of module pins from the PCB. If the PCB is too thick to allow good pin protrusion, consider using Vicor module accessories such as sockets to allow proper mounting.

Before soldering, the module should be mechanically affixed or immobilized with respect to the PCB to ensure no movement during the soldering process. The standoffs can be used for this process.

Vicor power modules contain two types of pins: power pins (which deliver the power to the load and are typically sized according to the rated output current) and signal pins (which typically carry very little current and are of a uniform size across a given product family). The larger the pin, the more soldering time required to form an adequate connection. In addition to the sizing of the pin the time required to create a robust connection will vary depending on several parameters:

1. **PCB Thickness.** The thicker the printed circuit board is, the more heat it is able to dissipate, and thus it will require more soldering time.
2. **Copper Trace Area.** Power pins require large copper traces to minimize resistive power losses in carrying the power to the load. Since the copper tends to conduct heat rather well, the actual size of these copper traces directly affect the amount of time necessary to heat the PCB socket.
3. **Copper Trace Thickness.** As above, the thickness of the copper trace is a function of output current of the module, and has a direct impact on the amount of soldering time. Typically, PCB copper thickness is specified in terms of weight per square foot, typically 2oz or 3oz copper for current-carrying planes.
4. **Soldering Iron Power.** A higher power soldering iron can source more heat and thus take less time to heat a PCB trace. When a soldering iron is heating a point on the board, everything that is adjacent to this point is being heated as well, including the Vicor power module. A large copper trace, because it conducts heat very well, will exhibit less of a thermal gradient and thus a low-power soldering iron will have to heat the whole trace to a higher temperature before the area close to the iron is hot enough to flow solder. Because the trace and board are both dissipating and conducting thermal energy, some irons may not have enough power to heat a trace to the temperature that will allow proper soldering.
5. **Tip Temperature.** Typical 63 / 37 solder melts at 392°F [200°C]. A higher tip temperature will bring the barrel and pin above the melting point of solder faster. However, a higher tip temperature may cause damage to the pad, printed circuit board, or module pin.
6. **Type of Solder.** The actual melting point of the solder varies depending on the type of solder used and affects the necessary temperature of the pad and pin for flow. Vicor recommends 63 / 37 SnPb solder for use on Vicor power modules.
7. **Tip Size.** A larger tip will be able to heat a larger surface area, thus lowering soldering time.

Since there are so many factors that influence soldering time, listing actual times is difficult. In general, it is recommended that the joint be examined post-process to ensure a quality soldering joint. If necessary, different parameters can then be varied in order to ensure a solid process. The soldering times listed in Table 23.1 can be used as a guideline for establishing more application and process-specific parameters. Below are some recommendations for general practice:

1. Do not run tip temperature above 750°F [400°C] because it will greatly increase the risk of damaging the pads, traces, printed circuit board, or Vicor power module. Check with the printed circuit board manufacturer for any additional recommendations with regards to temperature.
2. Apply the soldering iron to one side of the pin and pad and apply the solder to the other, allowing the heat from the pin and pad to melt the solder. Do not apply solder to the soldering iron and subsequently attempt to transfer it to the pad and pin. Melting the solder by applying it directly to the soldering iron does not guarantee adequate wetting on the joint and is not considered good technique.
3. Do not apply excessive pressure with the soldering iron to the printed circuit board, barrel, or pad. This could result in breaking a trace, dislodging a barrel or damaging the PCB, which becomes noticeably softer when heated.
4. Do not apply the soldering iron to a connection for an extended period of time or damage to the module could result. If the soldering times exceed the upper limit listed in Table 23.1, consider using a larger tip or a higher power soldering iron.
5. Make sure PCB pads and holes are clean prior to soldering.
6. Solders with no-clean flux may be used to facilitate soldering.
7. Keep the tip of the soldering iron clean and free from resin. Apply a small amount of solder directly to the tip of the iron. This process is known as tinning.
8. Be careful not to jar the module or PCB while the solder is cooling. This could result in a cold solder joint, a void in the barrel, or a cracked joint.
9. If it is necessary to re-solder a joint, remove all existing solder from the pad and pin prior to reapplying solder.
10. Use of a soldering gun is **not** recommended for soldering Vicor modules.
11. It is **not** recommended that Maxi, Mini, Micro module pins be trimmed under any circumstances.
12. The caps of the InMate socket are designed to repel solder. It is normal for this surface to be free of solder.

As a procedural benchmark, given a 750°F [400°C] temperature on a 60W iron with a 0.19in [3 mm] tip, approximate times to solder a Vicor power module to a 0.062in [1,5 mm] thick PCB board with an appropriately sized copper trace would be in the range of Table 23.1.

Converter Family	Pin Type	Soldering Time (Range)
VI-200 / VI-J00	Signal	3 – 5 seconds
VI-200	Power	5 – 8 seconds
VI-J00	Power	4 – 7 seconds
Maxi / Mini / Micro	Singal	3 – 5 seconds
Maxi	Power	5 – 8 seconds
Mini	Power	4 – 7 seconds

Table 23.1 — Recommended pin soldering times Vicor modules

Again, please note that soldering for significantly longer periods of time than the time listed above could result in damage to the module. The time listed in Table 23.1 should not be used without verifying that the times will produce a quality soldering joint as defined in the previous sections.

Wave Soldering. Vicor modules achieve an adequate solder connection on a wave soldering machine with conveyor speeds from three to seven feet per minute. As with hand soldering, times and parameters vary with the properties of the PCB and copper traces. As a standard benchmark the parameters below may be used. As with hand-soldered boards, the results should be examined to ensure a quality soldering joint and a sound process.

Wave Soldering Profile

1. Bottom-side preheaters: Zone 1: 650°F [343°C], Zone 2: 750°F [398°C]
2. Top-side preheaters: 203 – 248°F [95 – 120°C]
3. Wave temperature: 500°F [260°C]
4. Wave type: 4.25in [107,9mm] standard laminar wave

Preheating of the PCB is generally required for wave soldering operations to ensure adequate wetting of the solder to the PCB. The recommended temperature for PCB topside is 203 – 248°F [95 – 120°C] prior to the molten wave. Thick, multilayer PCBs should be heated toward the upper limit of this range, while simple two-layer PCBs should be heated to the lower limit. These parameters are consistent with generally accepted requirements for circuit-card assembly.

The power module is often much more massive than other components mounted to the PCB. During wave solder preheating, the pins will dissipate much of their absorbed heat within the module. Adjustments to preheaters alone, therefore, will not improve module soldering significantly.

A more effective way to improve the soldering of the module is to lower the conveyor speed and increase the dwell time in the molten wave. Approximately 5 seconds of exposure to the molten wave is required to achieve an acceptable solder joint for a Maxi, Mini or Micro power module.

Post Solder Cleaning. Vicor modules are not hermetically sealed and must not be exposed to liquid, including but not limited to cleaning solvents, aqueous washing solutions or pressurized sprays. Cleaning the back-side of the PCB is acceptable provided no solvent contacts the body of the module.

When soldering, it is recommended that no-clean flux solder be used, as this will ensure that potentially corrosive mobile ions will not remain on, around or under the module following the soldering process.

If the application requires the PCB to be subject to an aqueous wash after soldering, then it is recommended that Vicor module accessories such as through-hole or surface-mount sockets be used. These sockets should be mounted to the PCB and the modules subsequently inserted following the aqueous washing sequence.

De-soldering Vicor Modules. Vicor modules should not be re-used after desoldering for the following reasons:

1. Most de-soldering procedures introduce damaging mechanical and thermal stresses to the module.
2. Devices or processes that may be capable of de-soldering a Vicor module from a printed circuit board without causing damage have not been qualified for use with Vicor modules. For applications that require removal of a module with the intent of reuse, use Vicor socketing systems.

Index of Common Soldering defects.

1. **Solder Bridge.** A short circuit between two electrically unconnected points caused by a piece of solder inadvertently forming a "bridge" or connection between the two points.

Recommended Solution. Use a smaller soldering tip, or hold the tip at a different angle when soldering, so as to only contact one pad at a time.

2. **Cold Solder.** An incomplete or poor connection caused by either the barrel or the pin not being heated to the flow temperature of solder. A cold solder joint will typically exhibit a convex meniscus with possibly a dark spot around the barrel or pad. Also a cold solder joint will not be shiny, but will typically have a "dirty" appearance.

CAUTION: A cold solder joint is not necessarily an open connection electrically, and cannot be diagnosed by a simple continuity check. A cold solder joint is frequently an electrically intermittent connection and is best diagnosed by visual inspection. A cold solder joint will likely become electrically open following a period of temperature cycling.

Recommended Solution. Increase soldering iron temperature, soldering time or use a soldering iron with a higher output wattage if hand soldering. If wave soldering, lower conveyor speed or increase preheat temperature.

3. **PC Board Damage.** An intermittent or poor connection caused by damage to a trace, pad or barrel. A damaged pad is best identified by a burn mark on the PCB or a trace of pad that moves when prodded with a mechanical object.

Recommended Solution. Lower the soldering iron temperature or the soldering time. If damage persists use a lower power iron, or consult with the manufacturer of the PCB for recommended soldering guidelines.

4. **De-wetting.** The solder initially appears to wet but then pulls back to expose the pad surface, more common in wave soldering.

Recommended Solution. Make sure the PCB is clean prior to soldering.

5. **Dry Joint.** The solder has a dull gray appearance as opposed to a bright silver surface. The solder joint may have a mottled look as well, with jagged ridges. It is caused by the solder joint moving before completely cooled.

Recommended Solution. Immobilize the module with respect to the PCB to ensure that the solder joint cools properly.

6. **Icicles.** Jagged or conical extensions from solder fillet. These are caused by soldering with the temperature too low, or soldering to a highly heat-absorbent surface.

Recommended Solution. Increase the soldering temperature, but not outside the recommended limits. If necessary, use a higher power soldering iron.

7. **Pinholes.** Small or large holes in surface of solder joint, most commonly occurring in wave-solder systems.

Recommended Solution. Increase preheat or topside heater temperature, but not outside the recommended limits.

References

Organizations

www.ipc.org

Commercial

www.aimsolder.com

www.alphaassembly.com

www.kester.com

www.multicore-association.org

Maxi / Mini / Micro Standoff Kits for Solder-Mounted Modules

Board Thickness	Mounting Options		Slotted Baseplate		Through-Hole Baseplate		Threaded Baseplate
	Mounting Style	Pin Style	Through-Hole Heat Sink	Threaded Heat Sink	Through-Hole Heat Sink	Threaded Heat Sink	Through-Hole Heat Sink
0.062in (0.055 – 0.071in) 1,5mm (1,4 – 1,8mm)	Inboard	Short Tin/Lead	Kit-18150	Kit-18151	Kit-18146	Kit-18147	Kit-18146
			Bag-19126	Bag-19127	Bag-19122	Bag-19123	Bag-19122
	Onboard	L	Kit-18156	Kit-18157	Kit-18150	Kit-18152	Kit-18150
			Bag-19132	Bag-19133	Bag-19126	Bag-19128	Bag-19126
0.093in (0.084in/0.104in) 2,4mm (2,1 – 2,6mm)	Inboard	L	Kit-18150	Kit-18151	Kit-18146	Kit-18147	Kit-18146
			Bag-19126	Bag-19127	Bag-19122	Bag-19123	Bag-19122

Kits include six (6) standoffs and screws. Mini and Micro modules require a minimum of four (4) standoffs. Bags contain 100 standoffs only (#4-40 screws required).

Table 23.2 — Standoff kits for solder mounted modules



Figure 24.1 — Full- and half-size SlimMods

SlimMod™

Vicor PCB mount power components are available in flangeless “SlimMod” package configurations that provide users with narrower width 1.8in [45,7mm] for tight printed circuit mount applications.

To order the SlimMod configuration, add the suffix “S” to the standard part number. Example: VI-260-CV-S. SlimMod clips are available for grounding the baseplate to the PCB ground plane.

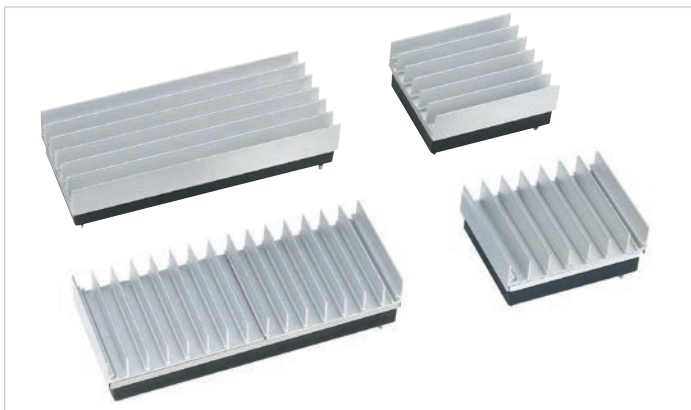

Figure 24.2 — Longitudinal and transverse FinMods

FinMod™

Vicor PCB mount power components are also available in flangeless “FinMod” package configurations with integral finned heat sinks. FinMods eliminate the need for secondary heat sink assembly operations.

The full-size and half-size module components are available with heat sink heights of 0.25in [6,35mm] and 0.5in [12,7mm] longitudinal or transverse fin versions. To order the longitudinal fin configurations add the suffix “F1” 0.25in [6,35mm] or “F2” 0.5in [12,7mm] to the standard part number.^[a] For transverse fins, add the suffix “F3” 0.25in [6,35mm] or “F4” 0.5in [12,7mm] to the standard part number.

^[a] FinMod clips are available for grounding the baseplate to the PCB ground plane.

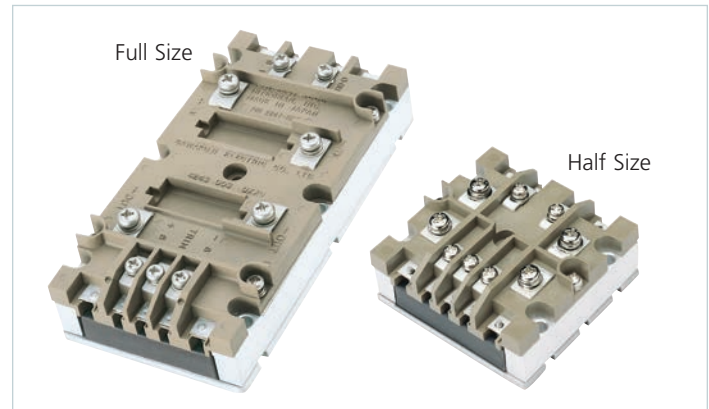

Figure 24.3 — BusMod module housing assembly

BusMod™

The BusMod is a rugged module housing assembly that combines convenient chassis mounting with a screw / lug wiring interface for all electrical connections. To order the BusMod option, add “-B1” to the standard part number.

NOTE: The BusMod may be used with any of Vicor VI-/MI-200, VI-/MI-J00, IAM or VI-/MI-RAM modules, with the exception of the HAM.



Figure 24.4 — MegaMods housing assembly

MegaMod™/MI-MegaMod DC-DC Converter Family

MegaMod/MI-MegaMod and MegaMod/MI-MegaMod Jr. DC-DC converters incorporate one, two or three Vicor VI-/MI-200 or VI-/MI-J00 DC-DC converters in a modular package to provide a chassis-mounted alternative to board-mounted power supplies. MegaMod/MI-MegaMods offer 50 – 600W of power from 1 – 3 outputs. MegaMod/MI-MegaMod Jr.s offer a total of 25 – 300W from 1 – 3 outputs. Each output may be independently sensed, adjusted, and sequenced using the procedures outlined for VI-/MI-200 and VI-/MI-J00 DC-DC converters.

Typical Weights for Vicor Products					
Product	Weight				
	Standard		Heat Sink Options		
DC-DC	VI-/MI-200 Family (Including SlimMod)	170g	[6.0oz]		
	VI-/MI-J00 Family	85g	[3.0oz]		
	BatMod	170g	[6.0oz]		
	BusMod				
	VI-2XX-XX-B1	357g	[12.6oz]		
	MI-2XX-XX-B1	357g	[12.6oz]		
	VI-JXX-XX-B1	181g	[6.4oz]		
	MI-JXX-XX-B1	181g	[6.4oz]		
	FinMod				
	VI-2XX-XX-F1, MI-2XX-MX-F1	198g	[7.0oz]		
VI-2XX-XX-F2, MI-2XX-MX-F2	213g	[7.5oz]			
VI-JXX-XX-F1, MI-JXX-MX-F1	99g	[3.5oz]			
VI-JXX-XX-F2, MI-JXX-MX-F2	113g	[4.0oz]			
MegaMod/MI-MegaMod Family					
L Family (1-up)	255g	[9.0oz]			
M and P Family (2-up)	545g	[1.2lbs]			
N, Q, R Family (3-up)	772g	[1.7 lbs]			
MegaMod/MI-MegaMod Jr. Family					
L Family (1-up)	127g	[4.5oz]			
P Family (2-up)	250g	[8.8oz]			
R Family (3-up)	377g	[13.3oz]			
ComPAC/MI-ComPAC Family –CC –H1					
LC Family (1-up)	545g	[1.2lbs]	636g –CC [1.4lbs]	590g –H1 [1.3lbs]	
MC Family (2-up)	1.248kg	[2.4lbs]	1.27kg [2.8lbs]	1.23kg [2.7lbs]	
NC Family (3-up)	1.633kg	[3.6lbs]	1.91kg [4.2lbs]	1.82kg [4.0lbs]	
AC-DC	AC Input Module (AIM/MI-AIM)	85g	[3.0oz]		
	Harmonic Attenuator Module (HAM)	170g	[6.0oz]		
	FlatPAC –CC				
	LU Family (1-up)	652g	[1.4lbs]	817g –CC [1.8lbs]	
	PU, MU Family (2-up)	1.248kg	[2.75lbs]	1.59kg [3.5lbs]	
	NU, QU, RU Family (3-up)	1.843kg	[4.0lbs]	2.32kg [5.1lbs]	
	Offline Front Ends (Includes Industrial Grade)				
	VI-FPE6-CUX (250W PC Mount)	184g	[6.5oz]		
	VI-FKE6-CUX (250W Chassis Mount)	340g	[12.0oz]		
	VI-FPE6-CQX (500W PC Mount)	391g	[13.8oz]		
VI-FKE6-CQX (500W Chassis Mount)	610g	[1.3lbs]			
VI-FPE6-CMX (750W PC Mount)	496g	[1.1lbs]			
VI-FPE6-CMX (750W Chassis Mount)	737g	[1.6lbs]			
3-Phase Front Ends					
VI-TKY6-CHX (1500W)	862g	[1.9lbs]			
VI-TKY6-CEX (3000W)	1.497kg	[3.3lbs]			
VI-TRY6-CCX (5000W)	2.857kg	[6.3lbs]			
Filters					
Input Attenuator Module (IAM/MI-IAM)	91g	[3.2oz]			
Ripple Attenuator Module (RAM/MI-RAM)	79g	[2.8oz]			
HAM Filter Part #30205 85g	85g	[13.6oz]			

A

AC-OK Signal: The signal used to indicate the loss of AC input voltage from the 115 / 230V line.

Altitude Testing: Generally performed to determine the proper functionality of equipment in airplanes and other flying objects. MIL-STD-810.

Ambient Temperature: The temperature of the environment, usually the still air in the immediate proximity of the power supply.

Apparent Power: A value of power for AC circuits that is calculated as the product of RMS current times RMS voltage, without taking power factor into account.

B

Bandwidth: A range of frequencies over which a certain phenomenon is to be considered.

Baseplate: All modular products have an aluminum mounting base at which Vicor specifies operating temperatures and which should be affixed to a thermally conductive surface for cooling.

Bellcore Specification: A telecommunications industry standard developed by Bellcore.

Bipolar Transistor: A transistor that operates by the action of minority carriers across a PN junction; and is a current controlled device as opposed to a voltage controlled device.

Bleeder Resistor: A resistor added to a circuit for the purpose of providing a small current drain, to assure discharge of capacitors.

Bobbin: A device upon which the windings of a transformer or inductor are wound, it provides a form for the coil and insulates the windings from the core.

Booster Converter: A "slave" module in a Driver / Booster combination, where the Driver is the master. Several Boosters can be paralleled with a Driver module for higher output power.

Breakdown Voltage: A voltage level at which dielectric insulation fails by excessive leakage current or arcing. In reference to power supplies the breakdown voltage is the maximum AC or DC voltage that can be applied from input to output and / or chassis.

Bridge Converter: A DC-DC converter topology (configuration) employing two or four active switching components in a bridge configuration across a power transformer.

Bridge Rectifier: A full wave rectifier circuit employing four rectifiers in a bridge configuration.

British Telecom Standards: A telecommunications industry standard developed by the British PTT authorities.

Brownout: A reduction of the AC mains distribution voltage, usually caused deliberately by the utility company to reduce power consumption when demand exceeds generation or distribution capacity.

Burn-In: Operating a newly manufactured power supply, usually at rated load, for a period of time in order to force component infant mortality failures or other latent defects.

C

Capacitive Coupling: Coupling of a signal between two circuits, due to discrete or parasitic capacitance between the circuits.

Center Tap: An electrical connection made at the center of a transformer or inductor winding, usually so as to result in an equal number of turns on either side of the tap.

Centralized Power Architecture (CPA): One of the oldest power systems architectures, generates all system voltages at a central location and distributes them to load locations via distribution buses. This can be effective if the voltages are high and the currents low or if the distances between the power supply and the loads are small.

C-Grade: Industry standard where the operating temperature of a device does not drop below -20°C .

Chassis-Mount Configuration: A configuration where the modules or AC front ends are mounted directly to the chassis.

Common-Mode Noise: Noise present equally on two conductors with respect to some reference point; often used specifically to refer to noise present on both the hot and neutral AC lines with respect to ground.

CompACT™: A Vicor DC input power supply that provides EMC filtering and transient suppression for industrial, military and telecommunications markets.

Constant-Current Power Supply: A power supply designed to regulate output current for changes in line, load, ambient temperature and drift resulting from time.

Constant-Voltage Power Supply: A power supply designed to regulate output voltage for changes in line, load, ambient temperature and drift resulting from time.

Control Circuit: A circuit in a closed-loop system, typically containing an error amplifier, that controls the operation of the system to achieve regulation.

Converter: An electrical circuit that accepts a DC input and generates a DC output of a different voltage usually achieved by high frequency switching action employing inductive and capacitive filter elements.

Crest Factor: In an AC circuit, the mathematical ratio of the peak to RMS values of a waveform. Crest factor is sometimes used for describing the current stress in AC mains supply wires, since for a given amount of power transferred, the RMS value, and hence the losses, become greater with increasing peak values. Crest factor gives essentially the same information as power factor, and is being replaced by power factor in power supply technology.

Cross Regulation: The effect of a load change on one output to the regulation of another output. It usually only applies to non postregulated (quasi) outputs.

Crowbar: An overvoltage protection method that shorts the power supply output to ground in order to protect the load when an overvoltage fault is detected.

CSA: Canadian Standards Association. Defines the standards and safety requirements for power components.

Current Limiting: An overload protection circuit that limits the maximum output current of a power supply in order to protect the load and/or the power supply.

Current Mode: A control method for switch-mode converters where the converter adjusts its regulating pulsewidth in response to measured output current and output voltage, using a dual loop control circuit.

Current Monitor: An analog power supply signal that is linearly proportional to output current flow.

D

DC-OK Signal: Signal used to monitor the status of the DC output.

De-rating: A reduction in an operating specification to improve reliability. For power supplies it is usually a specified reduction in output power to facilitate operation at higher temperatures.

Design Life: The expected lifetime of a power supply during which it will operate to its published specifications.

Differential-Mode Noise: Noise that is measured between two lines with respect to a common reference point excluding common-mode noise. The resultant measurement is the difference of the noise components of the two lines. The noise between the DC output and DC return is usually measured in power supplies.

Distributed Power Architecture (DPA): A power distribution architecture that replaces multiple central power sources with a single bulk supply that is converted to the end-use voltages by DC-DC converters located at the point of need. The growth of this design technique is demonstrated by the size of the DC-DC converter market. Distributed power can reduce the system size, reduce the system weight, provide better operation with battery power, and deliver more efficient sub-system isolation and redundancy.

Drift: The change in an output voltage, after a warm-up period, as a function of time when all other variables such as line, load and operating temperature are held constant.

Driver Module: The controlling module in a standalone or Driver / Booster configuration. The Driver module contains all the control circuitry.

Dropout: The lower limit of the AC input voltage where the power supply just begins to experience insufficient input to maintain regulation. The dropout voltage for linears is largely line dependent, whereas for most switchers it is largely load dependent, and to a smaller degree line dependent.

Dynamic Load Regulation: The delta in output voltage when the output load is rapidly changed.

E

Efficiency: The ratio of total output power to input power expressed as a percentage.

Electronic Load: An electronic device designed to provide a load to the outputs of a power supply, usually capable of dynamic loading, and frequently programmable or computer controlled.

EMC: Electromagnetic Compatibility. Relating to compliance with electromagnetic emissions and susceptibility standards.

EMI: Electromagnetic Interference. The generation of unwanted noise during the operation of a power supply or other electrical or electronic equipment.

ESR: Equivalent Series Resistance. The value of resistance in series with an ideal capacitor that duplicates the performance characteristics of a real capacitor.

F

Factorized Power Architecture (FPA™): A power distribution architecture that is inherently more granular and leverages an allocation of the DC-DC converter functions consistent with efficient power distribution principles. An optimal power distribution architecture should efficiently support demanding low voltage, high current loads. FPA is a higher level power architecture that offers dramatic improvements in onboard power distribution systems, in performance, reliability and economy.

Fault Tolerant Configuration: A method of parallel operation, using output Oring diodes, in which the failure of a single supply (module) will not result in a loss of power. The total current of the parallel system must not exceed the load requirements to a point where the failure of a single unit will not result in a system overload.

FET: Field Effect Transistor. A majority carrier-voltage controlled transistor.

FinMod™: A flangeless / finned packaging option available on the Vicor VI-/MI-Family converters and accessory modules.

FlatPAC™: A Vicor AC-DC switcher available with one, two or three outputs, with total power rating from 50 – 600W.

Floating Output: An output of a power supply that is not connected or referenced to any other output, usually denoting full galvanic isolation. Floating outputs can generally be used as either positive or negative outputs. Non floating outputs share a common return line and are hence DC referenced to one another.

Foldback Current Limiting: A type of protection circuit where the output current decreases as the overload increases. The output current reaches a minimum as the load approaches a short circuit condition.

Forward Converter: A switching power supply in which the energy is transferred from the input to the output during the “on” time of the primary switching device.

G

GATE IN: The GATE IN pin of the module may be used to turn the module on or off. When GATE IN is pulled low, the module is turned off. When GATE IN is floating (open collector) the module is turned on. The open circuit voltage of the GATE IN pin is less than 10V, referenced to –VIN. A GATE OUT / GATE IN connection is necessary to run Driver / Booster configurations.

GATE OUT: The GATE OUT pin is the clock pulse of the converter. It is used to synchronize Booster modules to a Driver module for high power arrays.

Ground: An electrical connection to earth or some other conductor that is connected to earth. Sometimes the term “ground” is used in place of “common,” but such usage is not correct unless the connection is also connected to earth.

Ground Loop: An unintentionally induced feedback loop caused by two or more circuits sharing a common electrical ground.

H

Haversine: A waveform that is sinusoidal in nature, but consists of a portion of a sine wave superimposed on another waveform. The input current waveform to a typical offline power supply has the form of a haversine.

Headroom: Used in conjunction with series pass regulators, headroom is the difference between the input and output voltages.

Heat Sink: A medium of high thermal mass that can absorb (sink) heat indefinitely with negligible change in temperature. Heat sinks are not necessarily needed with Vicor modules, and their use is highly dependent on the individual application, power and ambient temperature.

High Line Input: The maximum steady-state input voltage on the input pin.

Hipot: Abbreviation for high potential, and generally refers to the high voltages used to test dielectric withstand capability for regulatory agency electrical safety requirements.

Hold-Up Capacitor: A capacitor whose energy is used to provide output voltage for a period after the removal of input voltage.

Hold-Up Time: The length of time a power supply can operate in regulation after failure of the AC input. Linears have very short hold-up times due to the energy stored on the low-voltage secondary side output capacitors. Switchers have longer times due to higher-voltage primary-side energy storage capacitors.

Hot Swap: Insertion and extraction of a power supply into a system while power is applied.

I

I-Grade: Industry standard where the operation temperature of a device does not drop below -40°C .

Impedance: The ratio of voltage to current at a specified frequency.

Induced Noise: Noise generated in a circuit by varying a magnetic field produced by another circuit.

Input Line Filter: An internally or externally mounted lowpass or band-reject filter at the power supply input that reduces the noise fed into the power supply.

Inrush Current: The peak current flowing into a power supply the instant AC power is applied. This peak may be much higher than the steady state input current due to the charging of the input filter capacitors.

Inrush-Current Limiting: A circuit that limits the amount of inrush current when a power supply is turned on.

Isolation: Two circuits that are completely electrically separated with respect to DC potentials, and almost always AC potentials. In power supplies, it is defined as the electrical separation of the input and output via the transformer.

Isolation Voltage: The maximum AC or DC test voltage that may be applied from input to output and/or chassis of a power supply. Usually this has a time limit per preregulatory agency such as EN60950.

Intermediate Bus Architecture (IBA): A power distribution architecture that relies on non-isolated point-of-load regulators (niPOLs), reducing the PoL function to regulation and transformation. The niPOLs operate from an intermediate bus voltage provided by upstream isolated converters. However, IBA has inherent limitations that require tradeoffs between distribution and conversion loss that limit responsiveness to rapid load changes. IBA has proven effective as an interim method of containing power system cost while addressing the trend toward a proliferation of lower load voltages.

L

Leakage Current: A term relating to current flowing between the AC supply wires and earth ground. The term does not necessarily denote a fault condition. In power supplies, leakage current usually refers to the 60Hz current that flows through the EMC filter capacitors connected between the AC lines and ground (Y caps).

Linear Regulator: A regulating technique where a dissipative active device such as a transistor is placed in series with a power supply output to regulate the output voltage.

Line Regulation: The change in output voltage when the AC input voltage is changed from minimum to maximum specified.

Line Voltage (Mains): The sine wave voltage provided to the power supply, usually expressed in volts RMS.

Load Regulation: The change in output voltage when the load on the output is changed.

Local Sensing: Using the voltage output terminals of the power supply as sense points for voltage regulation.

Long-Term Stability: Power supply output voltage change due to time with all other factors held constant. This is expressed in percent and is a function of component aging.

Low Line: The minimum steady state voltage that can be applied between the +IN and -IN pins of a converter and still maintain output regulation.

M

Mains: The utility AC power distribution wires.

Margining: Adjusting a power supply output voltage up or down from its nominal setting in order to verify system performance margin with respect to supply voltage. This is usually done electrically by a system-generated control signal.

MegaMod™: A chassis mount packaging option that incorporates one, two or three VI-/MI-200 Family converters for single, dual or triple outputs having a combined power of up to 600W.

M-Grade: An industry standard where the operating temperature of a device does not drop below -55°C .

MIL-SPECS: Military standards that a device must meet to be used in military environments.

MiniMod™: A junior size (VI-/MI-J00) version of the VI-/MI-200 Family of DC-DC converters offering up to half the power in a 2.28 x 2.4 x 0.5in [57,9 x 61,0 x 12,7mm] package.

Minimum Load: The minimum load current / power that must be drawn from the power supply in order for the supply to meet its performance specifications. Less frequently, a minimum load is required to prevent the power supply from failing.

Module Evaluation Board: A test fixture used to evaluate Vicor DC-DC converters.

MTBF (Mean Time Between Failure): MTBF is the point at which 63% of a given population no longer meet specification. It can either be calculated or demonstrated. The usual calculation is per MIL-STD-217 Rev. E. Demonstrated reliability is usually determined by temperature accelerated life testing and is usually greater than calculated MTBF.

N

Nominal Input: The center value for the input voltage range.

Nominal Value: A usual, average, normal, or expected operating condition. This stated value will probably not be equal to the value actually measured.

O

Offline: A power supply that receives its input power from the AC line, without using a 50 / 60Hz power transformer prior to rectification and filtering, hence the term "offline" power supply.

Open Frame: A power supply where there is no external metal chassis; the power supply is provided to the end user essentially as a printed circuit board that provides mechanical support as well as supporting the components and making electrical connections.

Operating Temperature: The range of temperatures in which a unit can operate within specifications.

Optoisolator: An electro-optical device that transmits a signal across a DC isolation boundary.

ORing Diodes: Diodes used to isolate supplies from one another under a fault condition.

Output Filtering: Filter used to reduce switching power supply noise and ripple.

Output Good: A power supply status signal that indicates the output voltage is within a certain tolerance. An output that is either too high or too low will deactivate the Output Good signal.

Output Impedance: The ratio of change in output voltage to change in load current.

Output Noise: The AC component that may be present on the DC output of a power supply. Switch-mode power supply output noise usually has two components: a lower frequency component at the switching frequency of the converter and a high frequency component due to fast edges of the converter switching transitions. Noise should always be measured directly at the output terminals with a scope probe having an extremely short grounding lead.

Output-Power Rating: The maximum power in watts that the power supply can provide and still maintain safety agency approvals.

Output-Voltage Accuracy: See Setpoint Accuracy.

Overload Protection: A power supply protection circuit that limits the output current under overload conditions.

Overshoot: A transient output voltage change exceeding the high limit of the voltage accuracy specification caused by turning the power supply on or off, or abruptly changing line or load conditions.

Overtemp Warning: A TTL compatible signal that indicates an overtemperature condition exists in the power supply.

Overvoltage Protection (OVP): A circuit that either shuts down the power supply or crowbars the output in the event of an output overvoltage condition.

P

Parallel Boost: VI-/MI-200 Family Booster modules may be added to a Driver to create multi-kilowatt arrays. Boosters do not contain any feedback or control circuitry.

Parallel Operation: Connecting the outputs of two or more power supplies together for the purpose of obtaining a higher output current. This requires power supplies specially designed for load sharing.

PARD: Periodic And Random Deviation. Referring to the sum of all ripple and noise components on the DC output of a power supply, regardless of nature or source.

Peak Power: The absolute maximum output power that a power supply can produce without immediate damage. Peak power capability is typically well beyond the continuous output power capability and the resulting average power should not exceed rated specifications.

Pi Filter: A commonly used filter at the input of a switching supply or DC-DC converter to reduce reflected ripple current. The filter usually consists of two shunt capacitors with inductance between them.

Post Regulator: A secondary regulating circuit on an auxiliary output of a power supply that provides regulation on that output.

Power Fail: A power supply interface signal that gives a warning that the input voltage will no longer sustain full power regulated output.

Power Factor: The ratio of true power to apparent power in an AC circuit. In power conversion technology, power factor is used in conjunction with describing AC input current to the power supply.

Preload: A small amount of current drawn from a power supply to stabilize its operation.

Primary: The input section of an isolated power supply, it is connected to the AC mains and hence has dangerous voltage levels present.

Product Grade: The environmental and acceptance tests performed on Vicor products.

Pulse Width Modulation (PWM): A switching power conversion technique where the on-time (or width) of a duty cycle is modulated to control power transfer for regulating power supply outputs.

Push-Pull Converter: A switch-mode power supply topology that utilizes a center-tapped transformer and two power switches. The two switches are alternately driven on and off.

Q

Quasi-Regulated Output: The regulation of an auxiliary output that is accomplished by regulation of the main output. A transformer turns ratio, commensurate with the desired auxiliary output voltage, is used in conjunction with the output around which the main control loop is closed. Quasi-regulated outputs are significantly affected by second order effects in the converter.

R

Rated Output Current: The maximum load current that a power supply can provide at a specified ambient temperature.

Reflected Ripple Current: The RMS or peak-to-peak AC current present at the input of the power supply that is a result of the switching frequency of the converter.

Regulation: The ability of a power supply to maintain an output voltage within a specified tolerance as referenced to changing conditions of input voltage and / or load.

Regulation Band: The total error band allowable for an output voltage. This includes the effects of all of the types of regulation: line, load, temperature and time.

Regulatory Agencies: CSA: Canadian Standards Association; FCC: Federal Communications Commission; FTZ: Fernmelde Technisches Zentralamt; TÜV: Technischer Überwachungs Verein; U.L.: Underwriters Laboratory; VDE: Verband Deutscher Electrotechniker.

Remote Inhibit: A power supply interface signal, usually TTL compatible, that commands the power supply to shut down one or all outputs.

Remote On / Off: Enables power supply to be remotely turned on or off. Turn-on is typically performed by open circuit or TTL logic "1", and turn-off by switch closure or TTL logic "0".

Remote Sense: Wires connected in parallel with power supply output cables such that the power supply can sense the actual voltage at the load to compensate for voltage drops in the output cables and/or isolation devices.

Return: The designation of the common terminal for the power supply outputs. It carries the return current for the outputs.

Reverse-Voltage Protection: A protection circuit that prevents the power supply from being damaged in the event that a reverse voltage is applied at the input or output terminals.

RFI: Radio Frequency Interference. Undesirable noise produced by a power supply or other electrical or electronic device during its operation. In power supply technology, RFI is usually taken to mean the same thing as EMC.

Ripple and Noise: The amplitude of the AC component on the DC output of a power supply usually expressed in millivolts peak-to-peak or RMS. For a linear power supply it is usually at the frequency of the AC mains. For a switching power supply, it is usually at the switching frequency of the converter stage.

S

Safety Ground: A conductive path to earth that is designed to protect persons from electrical shock by shunting away any dangerous currents that might occur due to malfunction or accident.

Secondary: The output section of an isolated power supply, it is isolated from the AC mains and specially designed for safety of personnel who might be working with power on the system.

SELV: An acronym for Safety Extra Low Voltage, a term generally defined by the regulatory agencies as the highest voltage that can be contacted by a person and not cause injury. It is often specifically defined as 30V_{AC} or 42.4V_{DC}.

Setpoint Accuracy: Ratio of actual to specified output voltage.

Sequencing: The technique of establishing a desired order of activating the outputs of a multiple output power supply.

Soft Start: A technique for gradually activating a power supply circuit when the power supply is first turned on. This technique is generally used to provide a gradual rise in output voltages and inrush current limiting.

Soft Line: A condition where there is substantial impedance present in the AC mains feeding input power to a power supply. The input voltage to the power supply drops significantly with increasing load.

Split-Bobbin Winding: A transformer winding technique where the primary and secondary are wound side-by-side on a bobbin with an insulation barrier between them.

Standby Current: The input current drawn by a power supply when shut down by a control input (remote inhibit) or under no load.

Stiff Line: A condition where there is no significant impedance present in the AC mains feeding input power to a power supply. The input voltage to the power supply does not change appreciably with load.

Switching Frequency: The rate at which the DC voltage is switched on and off in a switching power supply.

T

Temperature Coefficient: The average output voltage change expressed as a percent per degree Celsius of ambient temperature change. This is usually specified for a predetermined temperature range.

Temperature De-rating: Reducing the output power of a power supply with increasing temperature to maintain reliable operation.

Thermal Pad: A phase change material (ThermMate) used as a thermal interface between the converter and a heat sink or chassis.

Thermal Protection: A power supply protection circuit that shuts the power supply down in the event of unacceptably high internal temperatures.

Topology: The design type of a converter, indicative of the configuration of switching transistors, utilization of the transformer, and type of filtering. Examples of topologies are the Flyback, Forward, Half Bridge, Full Bridge, Resonant and Zero-Current Switching.

Tracking: A characteristic in a multiple output power supply where any changes in the output voltage of one output caused by line, load, and/or temperature are proportional to similar changes in accompanying outputs.

Transient-Recovery Time: The time required for an output voltage to be within specified accuracy limits after a step change in line or load conditions.

True Power: In an AC circuit, true power is the actual power consumed. It is distinguished from apparent power by eliminating the reactive power component that may be present.

U

Undershoot: A transient output voltage change which does not meet the low limit of the voltage accuracy specification and is caused by turning the power supply on or off, or abruptly changing line or load conditions.

Universal Input: An AC input capable of operating from major AC lines worldwide, without straps or switches.

V

VI Chip® (VIC): VI Chips are the smallest power components available today – about the size of a 1/16 brick and very power dense. They can be used as building blocks to replace existing circuits (quarter bricks and silver box power supplies). VI Chips offer flexible thermal management: a low thermal impedance package and the design of the package simplifies heat sink design.

Voltage Balance: The difference in magnitudes, in percent, of two output voltages that have equal nominal voltage magnitudes but opposite polarities.

Voltage Mode: A method of closed loop control of a switching converter to correct for changes in the output voltage.

W

Warm-Up Drift: The initial change in the output voltage of a power supply in the time period between turn-on and when the power supply reaches thermal equilibrium at 25°C, full load and nominal line.

Warm-Up Time: The time required after initial turn-on for a power supply to achieve compliance to its performance specifications.

X

X-Capacitor: A capacitor connected across the supply lines to suppress normal mode interference.

Y

Y-Capacitor: Power conversion modules generally require bypass capacitors from line to chassis (earth ground) to shunt common-mode noise currents and keep them local to the converter. In cases where the converters are operating from rectified AC line voltage, the failure of a bypass capacitor could result in excessive leakage current to the equipment chassis thus creating a ground fault and shock hazard. For this reason, a special classification of capacitor, referred to as a Y-capacitor, is recommended. These capacitors contain a dielectric with unique “self-healing” properties to help prevent against excessive leakage.

To meet general EMC requirements (Section 9), Vicor recommends the use of Y-capacitors with all power conversion modules. Y-capacitors meet IEC384-14, EN132400, and UL1283 standards.

Z

Zero-Current Switching: The turn-on and turn-off of a switching device at zero current, resulting in essentially lossless switching. The zero-current-switching topology allows Vicor converters to operate at frequencies up to 1MHz, with efficiencies higher than 80% and power densities greater than conventional topologies.

Zero-Voltage Switching: This technique significantly minimizes the switching losses and dV/dt noise due to the discharge of the switching MOSFET junction capacitance and reverse recovery of the diode, and enables switch mode converters to operate at higher frequencies.

Limitation of Warranties

Information in this document is believed to be accurate and reliable. HOWEVER, THIS INFORMATION IS PROVIDED "AS IS" AND WITHOUT ANY WARRANTIES, EXPRESSED OR IMPLIED, AS TO THE ACCURACY OR COMPLETENESS OF SUCH INFORMATION. VICOR SHALL HAVE NO LIABILITY FOR THE CONSEQUENCES OF USE OF SUCH INFORMATION. IN NO EVENT SHALL VICOR BE LIABLE FOR ANY INDIRECT, INCIDENTAL, PUNITIVE, SPECIAL OR CONSEQUENTIAL DAMAGES (INCLUDING, WITHOUT LIMITATION, LOST PROFITS OR SAVINGS, BUSINESS INTERRUPTION, COSTS RELATED TO THE REMOVAL OR REPLACEMENT OF ANY PRODUCTS OR REWORK CHARGES).

Vicor reserves the right to make changes to information published in this document, at any time and without notice. You should verify that this document and information is current. This document supersedes and replaces all prior versions of this publication.

All guidance and content herein are for illustrative purposes only. Vicor makes no representation or warranty that the products and/or services described herein will be suitable for the specified use without further testing or modification. You are responsible for the design and operation of your applications and products using Vicor products, and Vicor accepts no liability for any assistance with applications or customer product design. It is your sole responsibility to determine whether the Vicor product is suitable and fit for your applications and products, and to implement adequate design, testing and operating safeguards for your planned application(s) and use(s).

VICOR PRODUCTS ARE NOT DESIGNED, AUTHORIZED OR WARRANTED FOR USE IN LIFE SUPPORT, LIFE-CRITICAL OR SAFETY-CRITICAL SYSTEMS OR EQUIPMENT. VICOR PRODUCTS ARE NOT CERTIFIED TO MEET ISO 13485 FOR USE IN MEDICAL EQUIPMENT NOR ISO/TS16949 FOR USE IN AUTOMOTIVE APPLICATIONS OR OTHER SIMILAR MEDICAL AND AUTOMOTIVE STANDARDS. VICOR DISCLAIMS ANY AND ALL LIABILITY FOR INCLUSION AND/OR USE OF VICOR PRODUCTS IN SUCH EQUIPMENT OR APPLICATIONS AND THEREFORE SUCH INCLUSION AND/OR USE IS AT YOUR OWN RISK.

Terms of Sale

The purchase and sale of Vicor products is subject to the Vicor Corporation Terms and Conditions of Sale which are available at: (<http://www.vicorpower.com/termsconditionswarranty>)

Export Control

This document as well as the item(s) described herein may be subject to export control regulations. Export may require a prior authorization from U.S. export authorities.

Contact Us: <http://www.vicorpower.com/contact-us>

Vicor Corporation
25 Frontage Road
Andover, MA, USA 01810
Tel: 800-735-6200
Fax: 978-475-6715
www.vicorpower.com

email

Customer Service: custserv@vicorpower.com
Technical Support: apps@vicorpower.com

©2020 Vicor Corporation. All rights reserved. The Vicor name is a registered trademark of Vicor Corporation.
All other trademarks, product names, logos and brands are property of their respective owners.