

## Dual Monolithic CMOS 12-Bit Multiplying DIGITAL-TO-ANALOG CONVERTERS

### FEATURES

- TWO DACs IN A 0.3" WIDE PACKAGE
- SINGLE +5V SUPPLY
- HIGH-SPEED DIGITAL INTERFACE:  
Serial—DAC7800  
8 + 4-Bit Parallel—DAC7801  
12-Bit Parallel—DAC7802
- MONOTONIC OVER TEMPERATURE
- LOW CROSSTALK:  $-94\text{dB}$  min
- FULLY SPECIFIED OVER  $-40^\circ\text{C}$  TO  $+85^\circ\text{C}$

### DESCRIPTION

The DAC7800, DAC7801 and DAC7802 are members of a new family of monolithic dual 12-bit CMOS multiplying Digital-to-Analog Converters (DACs). The digital interface speed and the AC multiplying performance are achieved by using an advanced CMOS process optimized for data conversion circuits. High stability on-chip resistors provide true 12-bit integral and differential linearity over the wide industrial temperature range of  $-40^\circ\text{C}$  to  $+85^\circ\text{C}$ .

The DAC7800 features a serial interface capable of clocking-in data at a rate of at least 10MHz. Serial data is clocked (edge triggered) MSB first into a 24-bit shift register and then latched into each DAC separately or simultaneously as required by the application. An asynchronous CLEAR control is provided for power-on reset or system calibration functions. It is packaged in a 16-pin 0.3" wide plastic DIP.

The DAC7801 has a 2-byte (8 + 4) double-buffered interface. Data is first loaded (level transferred) into the input registers in two steps for each DAC. Then both DACs are updated simultaneously. The DAC7801 features an asynchronous CLEAR control. The DAC7801 is packaged in a 24-pin 0.3"

### APPLICATIONS

- PROCESS CONTROL OUTPUTS
- ATE PIN ELECTRONICS LEVEL SETTING
- PROGRAMMABLE FILTERS
- PROGRAMMABLE GAIN CIRCUITS
- AUTO-CALIBRATION CIRCUITS

wide plastic DIP. The DAC7802 has a single-buffered 12-bit data word interface. Parallel data is loaded (edge triggered) into the single DAC register for each DAC. The DAC7802 is packaged in a 24-pin 0.3" wide plastic DIP.

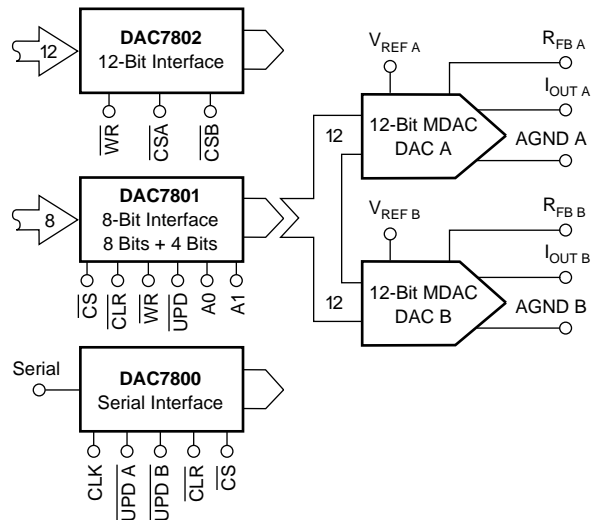

Please be aware that an important notice concerning availability, standard warranty, and use in critical applications of Texas Instruments semiconductor products and disclaimers thereto appears at the end of this data sheet.

All trademarks are the property of their respective owners.

## ABSOLUTE MAXIMUM RATINGS<sup>(1)</sup>

At  $T_A = +25^\circ\text{C}$ , unless otherwise noted.

$V_{DD}$ to AGND .....	0V, +7V
$V_{DD}$ to DGND .....	0V, +7V
AGND to DGND .....	-0.3, $V_{DD}$
Digital Input to DGND .....	-0.3, $V_{DD} + 0.3$
$V_{REF A}$ , $V_{REF B}$ to AGND .....	$\pm 16\text{V}$
$V_{REF A}$ , $V_{REF B}$ to DGND .....	$\pm 16\text{V}$
$I_{OUT A}$ , $I_{OUT B}$ to AGND .....	-0.3, $V_{DD}$
Storage Temperature Range .....	$-55^\circ\text{C}$ to $+125^\circ\text{C}$
Operating Temperature Range .....	$-40^\circ\text{C}$ to $+85^\circ\text{C}$
Lead Temperature (soldering, 10s) .....	$+300^\circ\text{C}$
Junction Temperature .....	$+175^\circ\text{C}$

NOTE: (1) Stresses above those listed under "Absolute Maximum Ratings" may cause permanent damage to the device. Exposure to absolute maximum conditions for extended periods may affect device reliability.



## ELECTROSTATIC DISCHARGE SENSITIVITY

This integrated circuit can be damaged by ESD. Texas Instruments recommends that all integrated circuits be handled with appropriate precautions. Failure to observe proper handling and installation procedures can cause damage.

ESD damage can range from subtle performance degradation to complete device failure. Precision integrated circuits may be more susceptible to damage because very small parametric changes could cause the device not to meet its published specifications.

## PACKAGE/ORDERING INFORMATION

PRODUCT	RELATIVE ACCURACY	GAIN ERROR	PACKAGE-LEAD	PACKAGE DESIGNATOR <sup>(1)</sup>	SPECIFIED TEMPERATURE RANGE	PACKAGE MARKING	ORDERING NUMBER	TRANSPORT MEDIA, QUANTITY
DAC7800KP	$\pm 1\text{LSB}$	$\pm 3\text{LSB}$	DIP-16	N	$-40^\circ\text{C}$ to $+85^\circ\text{C}$	DAC7800KP	DAC7800KP	Rails, 25
DAC7800LP	$\pm 1/2\text{ LSB}$	$\pm 1\text{LSB}$	DIP-16	N		DAC7800LP	DAC7800LP	Rails, 25
DAC7800KU	—	—	SO-16	DW	$-40^\circ\text{C}$ to $+85^\circ\text{C}$	DAC7800KU	DAC7800KU/1K	Tape and Reel, 1000
DAC7800LU	—	—	SO-16	DW		DAC7800LU	DAC7800LU/1K	Tape and Reel, 1000
DAC7801KP	$\pm 1\text{LSB}$	$\pm 3\text{LSB}$	DIP-24	NTG	$-40^\circ\text{C}$ to $+85^\circ\text{C}$	DAC7801KP	DAC7801KP	Rails, 15
DAC7801LP	$\pm 1/2\text{ LSB}$	$\pm 1\text{LSB}$	DIP-24	NTG		DAC7801LP	DAC7801LP	Rails, 15
DAC7801KU	—	—	SO-24	DW	$-40^\circ\text{C}$ to $+85^\circ\text{C}$	DAC7801KU	DAC7801KU/1K	Tape and Reel, 1000
DAC7801LU	—	—	SO-24	DW		DAC7801LU	DAC7801LU/1K	Tape and Reel, 1000
DAC7802KP	$\pm 1\text{LSB}$	$\pm 3\text{LSB}$	DIP-24	NTG	$-40^\circ\text{C}$ to $+85^\circ\text{C}$	DAC7802KP	DAC7802KP	Rails, 15
DAC7802LP	$\pm 1/2\text{ LSB}$	$\pm 1\text{LSB}$	DIP-24	NTG		DAC7802LP	DAC7802LP	Rails, 15
DAC7802KU	—	—	SO-24	DW	$-40^\circ\text{C}$ to $+85^\circ\text{C}$	DAC7802KU	DAC7802KU/1K	Tape and Reel, 1000
DAC7802LU	—	—	SO-24	DW		DAC7802LU	DAC7802LU/1K	Tape and Reel, 1000

NOTE: (1) For the most current specifications and package information, see the package option addendum located at the end of this data sheet.

## ELECTRICAL CHARACTERISTICS

At  $V_{DD} = +5\text{VDC}$ ,  $V_{REF A} = V_{REF B} = +10\text{V}$ ,  $T_A = -40^\circ\text{C}$  to  $+85^\circ\text{C}$ , unless otherwise noted.

PARAMETER	CONDITIONS	DAC7800, 7801, 7802K			DAC7800, 7801, 7802L			UNITS
		MIN	TYP	MAX	MIN	TYP	MAX	
<b>ACCURACY</b>								
Resolution	Measured Using $R_{FB A}$ and $R_{FB B}$ . All Registers Loaded with All 1s.	12			*			Bits
Relative Accuracy				$\pm 1$			$\pm 1/2$	LSB
Differential Nonlinearity				$\pm 1$			*	LSB
Gain Error				$\pm 3$			$\pm 1$	LSB
Gain Temperature Coefficient <sup>(1)</sup>	$T_A = +25^\circ\text{C}$ $T_A = -40^\circ\text{C}$ to $+85^\circ\text{C}$		2	5		*	*	ppm/ $^\circ\text{C}$
Output Leakage Current			0.005	10		*	*	nA
			3	150		*	*	nA
<b>REFERENCE INPUT</b>								
Input Resistance		6	10	14	*	*	*	k $\Omega$
Input Resistance Match			0.5	3		*	2	%
<b>DIGITAL INPUTS</b>								
$V_{IH}$ (Input HIGH Voltage)	$T_A = +25^\circ\text{C}$ $T_A = -40^\circ\text{C}$ to $+85^\circ\text{C}$	2			*			V
$V_{IL}$ (Input LOW Voltage)				0.8			*	V
$I_{IN}$ (Input Current)				$\pm 1$			*	$\mu\text{A}$
				$\pm 10$			*	$\mu\text{A}$
$C_{IN}$ (Input Capacitance)			0.8	10		*	*	pF
<b>POWER SUPPLY</b>								
$V_{DD}$	$V_{DD}$ from 4.5V to 5.5V	4.5		5.5	*		*	V
$I_{DD}$			0.2	2		*	*	mA
Power-Supply Rejection				0.002			*	%/%

\* Same specification as for DAC7800, 7801, 7802K.

## AC PERFORMANCE

### OUTPUT OP AMP IS OPA602.

At  $V_{DD} = +5VDC$ ,  $V_{REF A} = V_{REF B} = +10V$ ,  $T_A = +25^\circ C$ , unless otherwise noted. These specifications are fully characterized but not subject to test.

PARAMETER	CONDITIONS	DAC7800, 7801, 7802K			DAC7800, 7801, 7802L			UNITS
		MIN	TYP	MAX	MIN	TYP	MAX	
OUTPUT CURRENT SETTLING TIME	To 0.01% of Full-Scale $R_L = 100\Omega$ , $C_L = 13pF$		0.4	0.8		*	*	$\mu s$
DIGITAL-TO-ANALOG GLITCH IMPULSE	$V_{REF A} = V_{REF B} = 0V$ $R_L = 100\Omega$ , $C_L = 13pF$		0.9			*		nV-s
AC FEEDTHROUGH	$f_{VREF} = 10kHz$		-75	-72		*	*	dB
OUTPUT CAPACITANCE	DAC Loaded with All 0s DAC Loaded with All 1s		30 70	50 100		*	*	pF pF
CHANNEL-TO-CHANNEL ISOLATION $V_{REF A}$ to $I_{OUT B}$	$f_{VREF A} = 10kHz$ $V_{REF B} = 0V$ , Both DACs Loaded with 1s	-90	-94		*	*		dB
$V_{REF B}$ to $I_{OUT A}$	$f_{VREF B} = 10kHz$ $V_{REF A} = 0V$ , Both DACs Loaded with 1s	-90	-101		*	*		dB
DIGITAL CROSSTALK	Full-Scale Transition $R_L = 100\Omega$ , $C_L = 13pF$		0.9			*		nV-s

\* Same specification as for DAC7800, 7801, and 7802K.

NOTE: (1) Ensured but not tested.

## DAC7800

### BLOCK DIAGRAM

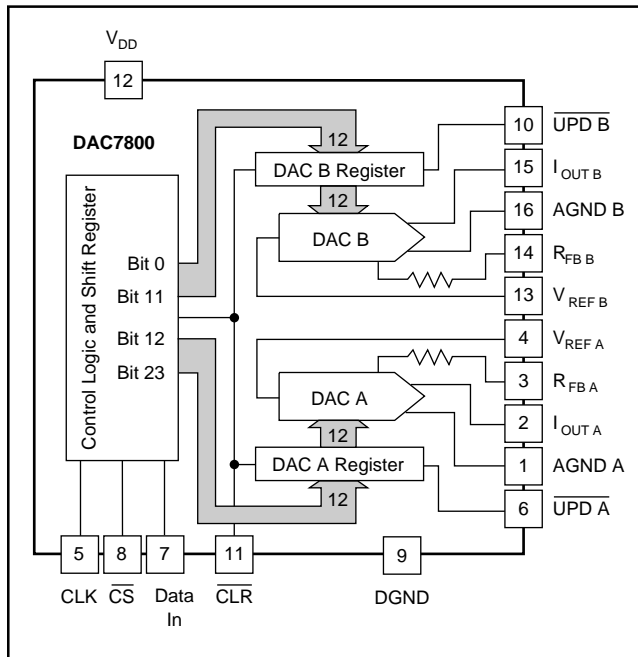

### PIN CONFIGURATION

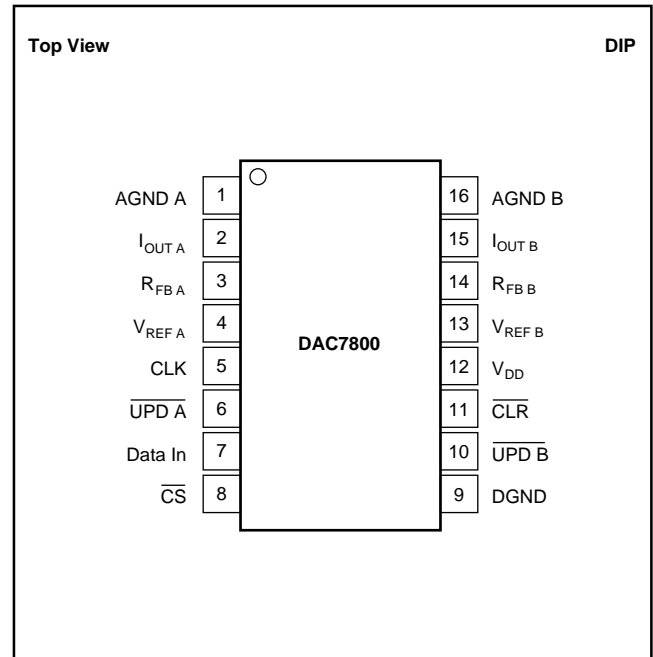

### LOGIC TRUTH TABLE

CLK	UPD A	UPD B	CS	CLR	FUNCTION
X	X	X	X	0	All register contents set to 0's (asynchronous).
X	X	X	1	X	No data transfer.
$\bar{1}$	X	X	0	1	Input data is clocked into input register (location Bit 23) and previous data shifts.
X	0	1	0	1	Input register bits 23 (LSB) - 12 (MSB) are loaded into DAC A.
X	1	0	0	1	Input register bits 11 (LSB) - 0 (MSB) are loaded into DAC B.
X	0	0	0	1	Input register bits 23 (LSB) - 12 (MSB) are loaded into DAC A, and input register bits 11 (LSB) - 0 (MSB) are loaded into DAC B.

X = Don't care.  $\bar{1}$  means falling edge triggered.



# DAC7801

## BLOCK DIAGRAM

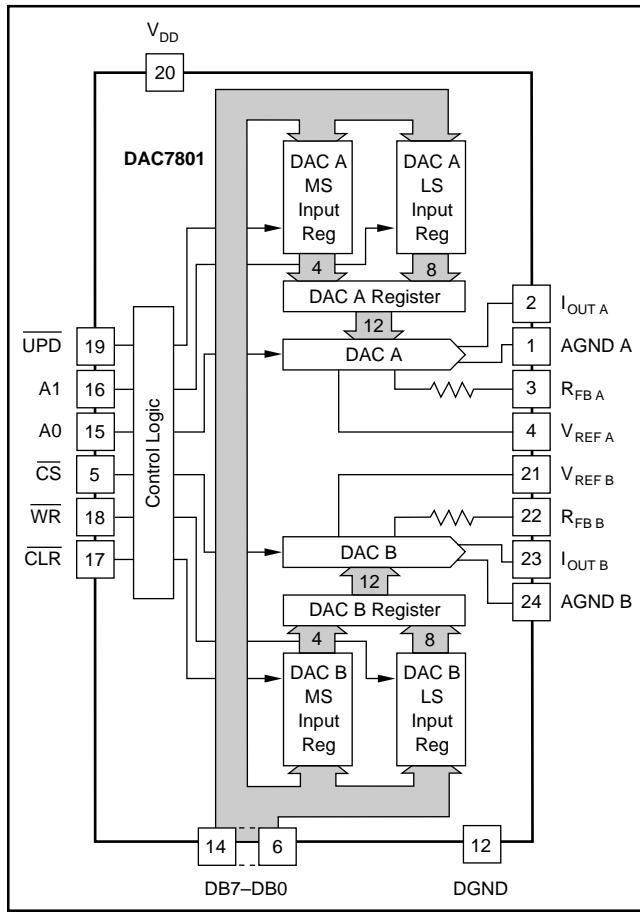

## PIN CONFIGURATION

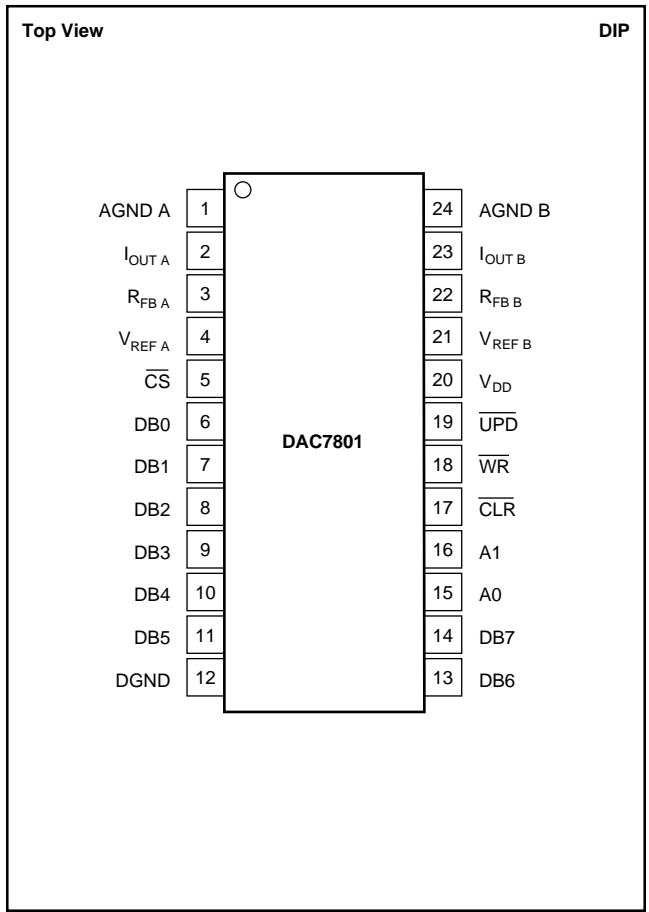

## LOGIC TRUTH TABLE

CLR	UPD	CS	WR	A1	A0	FUNCTION
1	1	1	X	X	X	No Data Transfer
1	1	X	1	X	X	No Data Transfer
0	X	X	X	X	X	All Registers Cleared
1	1	0	0	0	0	DAC A LS Input Register Loaded with DB7 - DB0 (LSB)
1	1	0	0	0	1	DAC A MS Input Register Loaded with DB3 (MSB) - DB0
1	1	0	0	1	0	DAC B LS Input Register Loaded with DB7 - DB0 (LSB)
1	1	0	0	1	1	DAC B MS Input Register Loaded with DB3 (MSB) - DB0
1	0	1	0	X	X	DAC A, DAC B Registers Updated Simultaneously from Input Registers
1	0	0	0	X	X	DAC A, DAC B Registers are Transparent

X = Don't care.

## TIMING CHARACTERISTICS

V<sub>DD</sub> = +5V, V<sub>REF A</sub> = V<sub>REF B</sub> = +10V, T<sub>A</sub> = -40°C to +85°C.

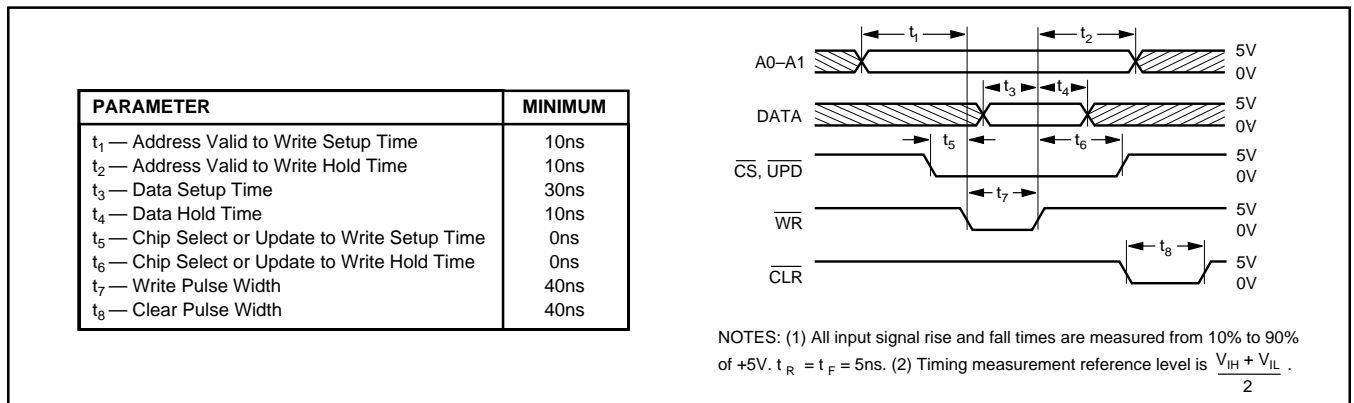

# DAC7802

## BLOCK DIAGRAM

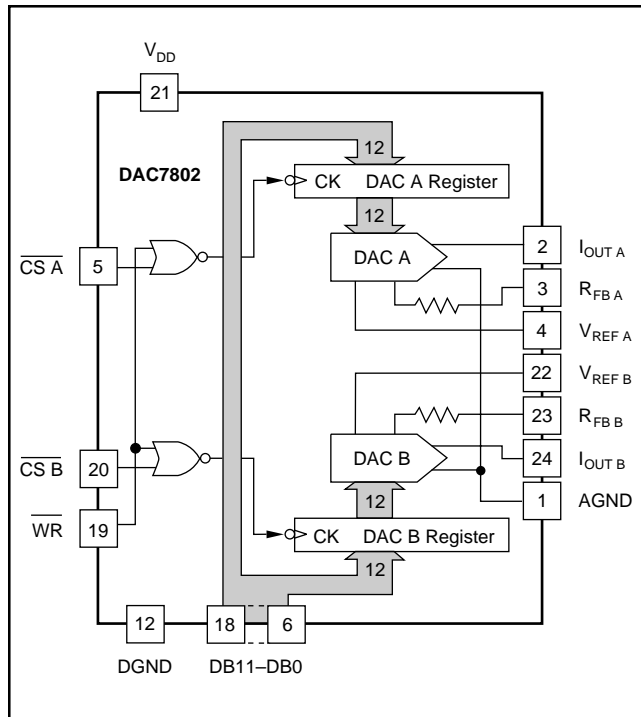

## PIN CONFIGURATION

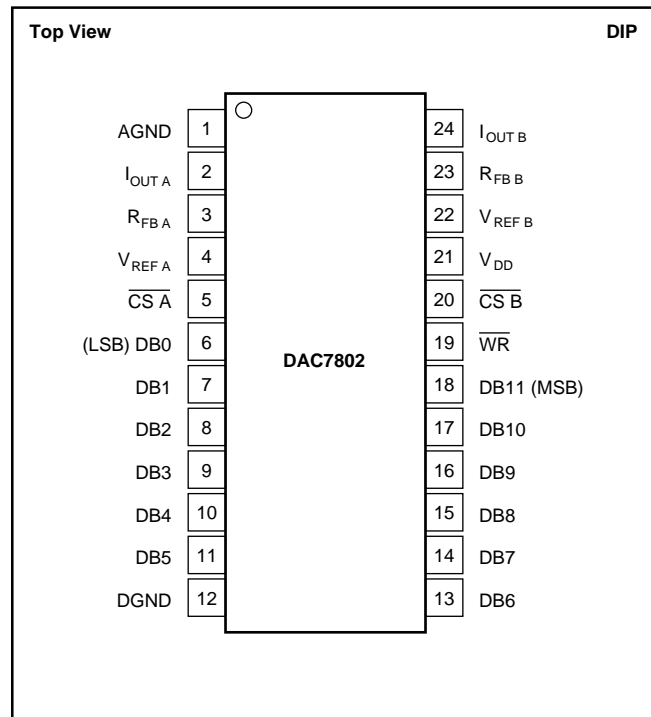

## TIMING CHARACTERISTICS

At  $V_{DD} = +5V$ , and  $T_A = -40^\circ C$  to  $+85^\circ C$ .

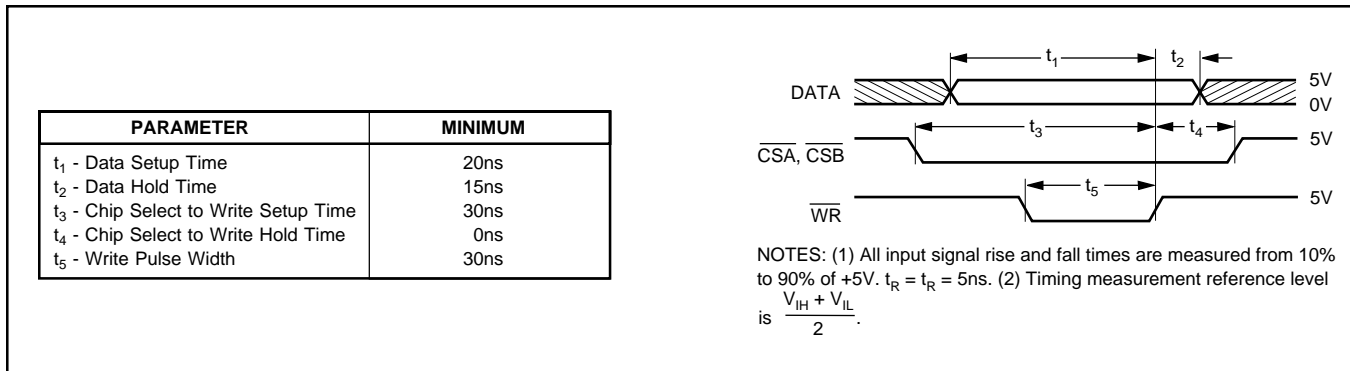

## LOGIC TRUTH TABLE

CSA	CSB	WR	FUNCTION
X	X	1	No Data Transfer
1	1	X	No Data Transfer
$\uparrow$	$\uparrow$	0	A Rising Edge on $\overline{CSA}$ or $\overline{CSB}$ Loads Data to the Respective DAC
0	1	$\uparrow$	DAC A Register Loaded from Data Bus
1	0	$\uparrow$	DAC B Register Loaded from Data Bus
0	0	$\uparrow$	DAC A and DAC B Registers Loaded from Data Bus

X = Don't care.  $\uparrow$  means rising edge triggered.

# TYPICAL CHARACTERISTICS

OUTPUT OP AMP IS OPA602.

$T_A = +25^\circ\text{C}$ ,  $V_{DD} = +5\text{V}$ .

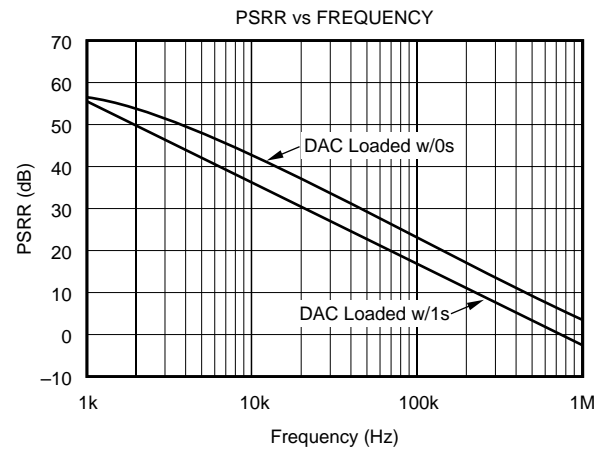
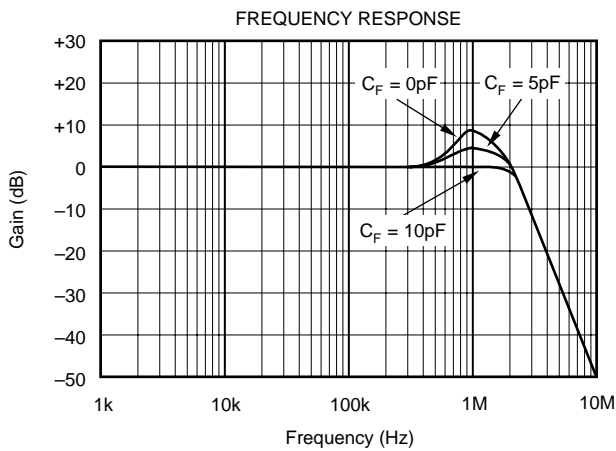
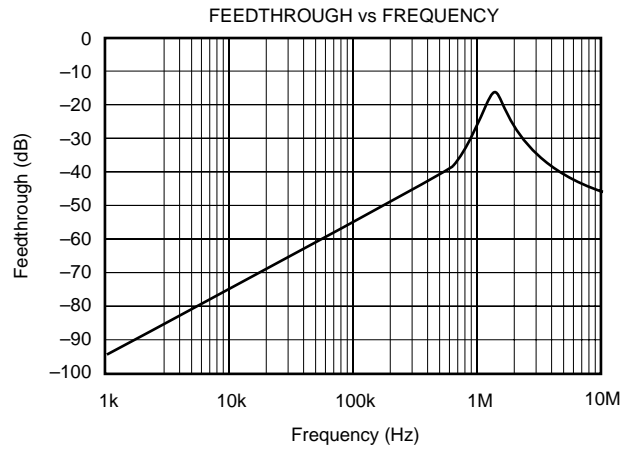
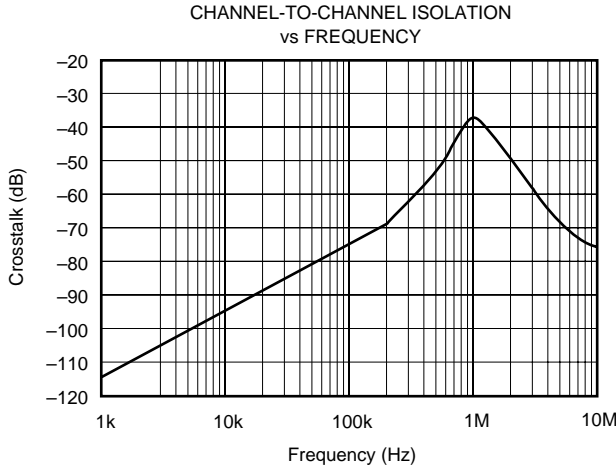
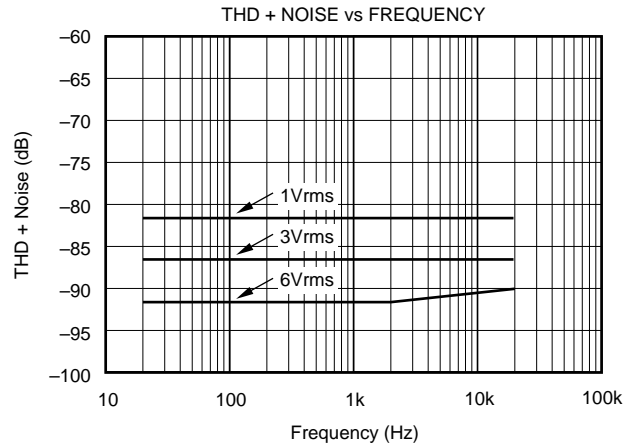
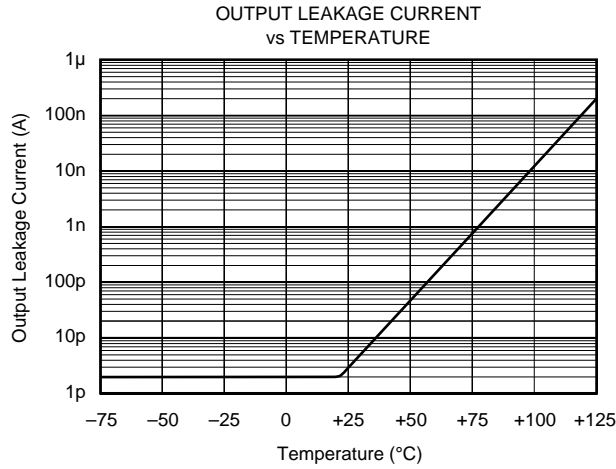

# DISCUSSION OF SPECIFICATIONS

## RELATIVE ACCURACY

This term, also known as end point linearity or integral linearity, describes the transfer function of analog output to digital input code. Relative accuracy describes the deviation from a straight line, after zero and full-scale errors have been adjusted to zero.

## DIFFERENTIAL NONLINEARITY

Differential nonlinearity is the deviation from an ideal 1LSB change in the output when the input code changes by 1LSB. A differential nonlinearity specification of 1LSB maximum ensures monotonicity.

## GAIN ERROR

Gain error is the difference between the full-scale DAC output and the ideal value. The ideal full scale output value for the DAC780x is  $-(4095/4096)V_{REF}$ . Gain error may be adjusted to zero using external trims, see Figures 5 and 7.

## OUTPUT LEAKAGE CURRENT

The current which appears at  $I_{OUT A}$  and  $I_{OUT B}$  with the DAC loaded with all zeros.

## OUTPUT CAPACITANCE

The parasitic capacitance measured from  $I_{OUT A}$  or  $I_{OUT B}$  to AGND.

## CHANNEL-TO-CHANNEL ISOLATION

The AC output error due to capacitive coupling from DAC A to DAC B or DAC B to DAC A.

## MULTIPLYING FEEDTHROUGH ERROR

The AC output error due to capacitive coupling from  $V_{REF}$  to  $I_{OUT}$  with the DAC loaded with all zeros.

## OUTPUT CURRENT SETTling TIME

The time required for the output current to settle to within  $\pm 0.01\%$  of final value for a full-scale step.

## DIGITAL-TO-ANALOG GLITCH ENERGY

The integrated area of the glitch pulse measured in nanovolt-seconds. The key contributor to DAC glitch is charge injected by digital logic switching transients.

## DIGITAL CROSSTALK

Glitch impulse measured at the output of one DAC but caused by a full-scale transition on the other DAC. The integrated area of the glitch pulse is measured in nanovolt-seconds.

# CIRCUIT DESCRIPTION

Figure 1 shows a simplified schematic of one half of a DAC780x. The current from the  $V_{REF A}$  pin is switched between  $I_{OUT A}$  and AGND by 12 single-pole double-throw CMOS switches. This maintains a constant current in each leg of the ladder regardless of the input code. The input resistance at  $V_{REF}$  is therefore

constant and can be driven by either a voltage or current, AC or DC, positive or negative polarity, and have a voltage range up to  $\pm 20V$ .

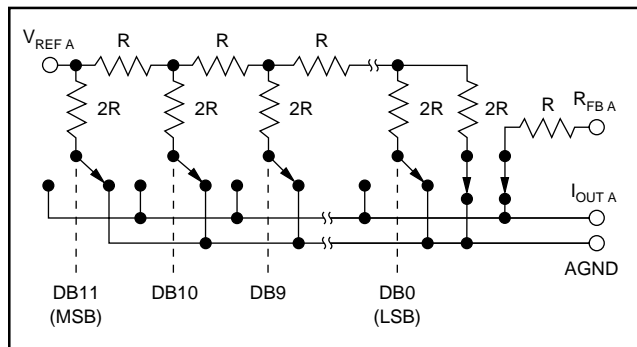

FIGURE 1. Simplified Circuit Diagram for DAC A.

A CMOS switch transistor, included in series with the ladder terminating resistor and in series with the feedback resistor,  $R_{FB A}$ , compensates for the temperature drift of the ON resistance of the ladder switches.

Figure 2 shows an equivalent circuit for DAC A.  $C_{OUT}$  is the output capacitance due to the N-channel switches and varies from about 30pF to 70pF with digital input code. The current source  $I_{LKG}$  is the combination of surface and junction leakages to the substrate.  $I_{LKG}$  approximately doubles every  $10^{\circ}C$ .  $R_O$  is the equivalent output resistance of the DAC and it varies with input code.

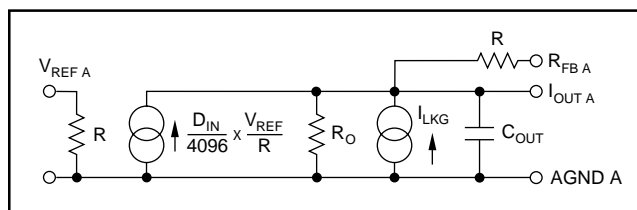

FIGURE 2. Equivalent Circuit for DAC A.

# INSTALLATION

## ESD PROTECTION

All digital inputs of the DAC780x incorporate on-chip ESD protection circuitry. This protection is designed to withstand 2.5kV (using the Human Body Model, 100pF and 1500Ω). However, industry standard ESD protection methods should be used when handling or storing these components. When not in use, devices should be stored in conductive foam or rails. The foam or rails should be discharged to the destination socket potential before devices are removed.

## POWER-SUPPLY CONNECTIONS

The DAC780x are designed to operate on  $V_{DD} = +5V \pm 10\%$ . For optimum performance and noise rejection, power-supply decoupling capacitors  $C_D$  should be added as shown in the application circuits. These capacitors (1μF tantalum recommended) should be located close to the DAC. AGND and



DGND should be connected together at one point only, preferably at the power-supply ground point. Separate returns minimize current flow in low-level signal paths if properly connected. Output op amp analog common (+ input) should be connected as near to the AGND pins of the DAC780x as possible.

### WIRING PRECAUTIONS

To minimize AC feedthrough when designing a PC board, care should be taken to minimize capacitive coupling between the  $V_{REF}$  lines and the  $I_{OUT}$  lines. Similarly, capacitive coupling between DACs may compromise the channel-to-channel isolation. Coupling from any of the digital control or data lines might degrade the glitch and digital crosstalk performance. Solder the DAC780x directly into the PC board without a socket. Sockets add parasitic capacitance (which can degrade AC performance).

### AMPLIFIER OFFSET VOLTAGE

The output amplifier used with the DAC780x should have low input offset voltage to preserve the transfer function linearity. The voltage output of the amplifier has an error component which is the offset voltage of the op amp multiplied by the “noise gain” of the circuit. This “noise gain” is equal to  $(R_F/R_O + 1)$  where  $R_O$  is the output impedance of the DAC  $I_{OUT}$  terminal and  $R_F$  is the feedback network impedance. The nonlinearity occurs due to the output impedance varying with code. If the 0 code case is excluded (where  $R_O = \infty$ ), the  $R_O$  will vary from  $R/3R$  providing a “noise gain” variation between  $4/3$  and  $2$ . In addition, the variation of  $R_O$  is nonlinear with code, and the largest steps in  $R_O$  occur at major code transitions where the worst differential nonlinearity is also likely to be experienced. The nonlinearity seen at the amplifier output is  $2V_{OS} - 4V_{OS}/3 = 2V_{OS}/3$ . Thus, to maintain good nonlinearity the op amp offset should be much less than  $1/2$  LSB.

### UNIPOLAR CONFIGURATION

Figure 3 shows DAC780x in a typical unipolar (two-quadrant) multiplying configuration. The analog output values versus digital input code are listed in Table II. The operational amplifiers used in this circuit can be single amplifiers such as the OPA602, or a dual amplifier such as the OPA2107. C1 and C2 provide phase compensation to minimize settling time and overshoot when using a high speed operational amplifier. If an application requires the DAC to have zero gain error, the circuit shown in Figure 4 may be used. Resistors  $R_2$  and  $R_4$  induce a positive gain error greater than worst-case initial negative gain error. Trim resistors  $R_1$  and  $R_3$  provide a variable negative gain error and have sufficient trim range to correct for the worst-case initial positive gain error plus the error produced by  $R_2$  and  $R_4$ .

### BIPOLAR CONFIGURATION

See Figure 5 for the DAC780x in a typical bipolar (four-quadrant) multiplying configuration. See Table III for the listing of the analog output values versus digital input code.

DATA INPUT		ANALOG OUTPUT
MSB ↓	↓ LSB	$-V_{REF}$ (4095/4096)
1111 1111 1111		$-V_{REF}$ (2048/4096) = $-1/2V_{REF}$
1000 0000 0000		$-V_{REF}$ (1/4096)
0000 0000 0001		0 Volts
0000 0000 0000		

TABLE II. Unipolar Output Code.

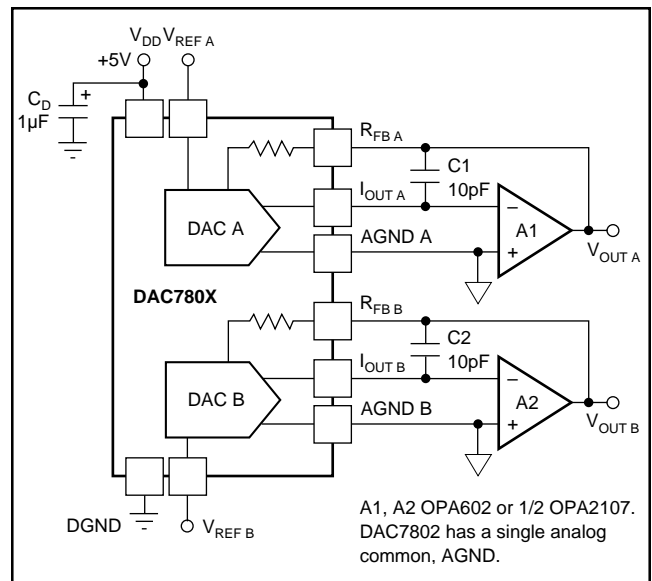

FIGURE 3. Unipolar Configuration.

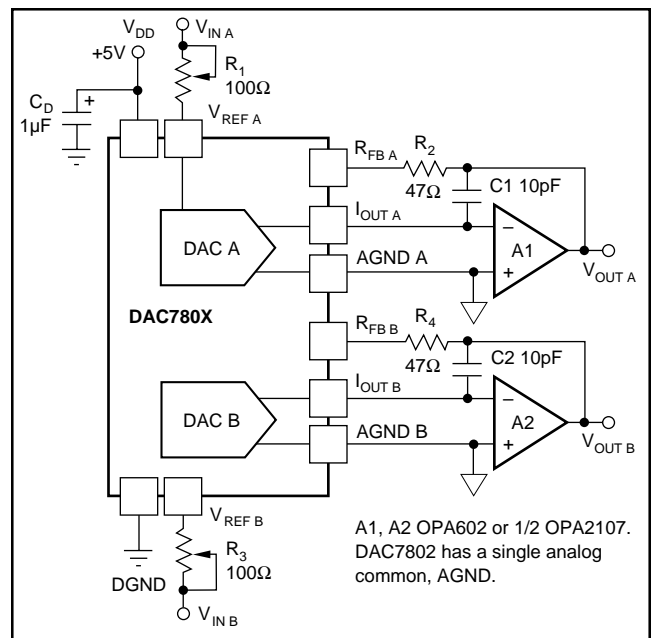

FIGURE 4. Unipolar Configuration with Gain Trim.

The operational amplifiers used in this circuit can be single amplifiers such as the OPA602, a dual amplifier such as the OPA2107, or a quad amplifier like the OPA404. C1 and C2 provide phase compensation to minimize settling time and overshoot when using a high speed operational amplifier. The bipolar offset resistors  $R_5$ – $R_7$  and  $R_8$ – $R_{10}$  should be ratio-matched to 0.01% to ensure the specified gain error performance.

If an application requires the DAC to have zero gain error, the circuit may be used, see Figure 6. Resistors  $R_2$  and  $R_4$  induce a positive gain error greater than worst-case initial negative gain error. Trim resistors  $R_1$  and  $R_3$  provide a variable negative gain error and have sufficient trim range to correct for the worst-case initial positive gain error plus the error produced by  $R_2$  and  $R_4$ .

DATA INPUT		ANALOG OUTPUT	
MSB ↓	↓ LSB	$+V_{REF}$ (2047/2048)	
1111 1111 1111		$+V_{REF}$ (1/2048)	
1000 0000 0001		0 Volts	
1000 0000 0000		$-V_{REF}$ (1/2048)	
0111 1111 1111		$-V_{REF}$ (2048/2048)	
0000 0000 0000			

TABLE III. Bipolar Output Code.

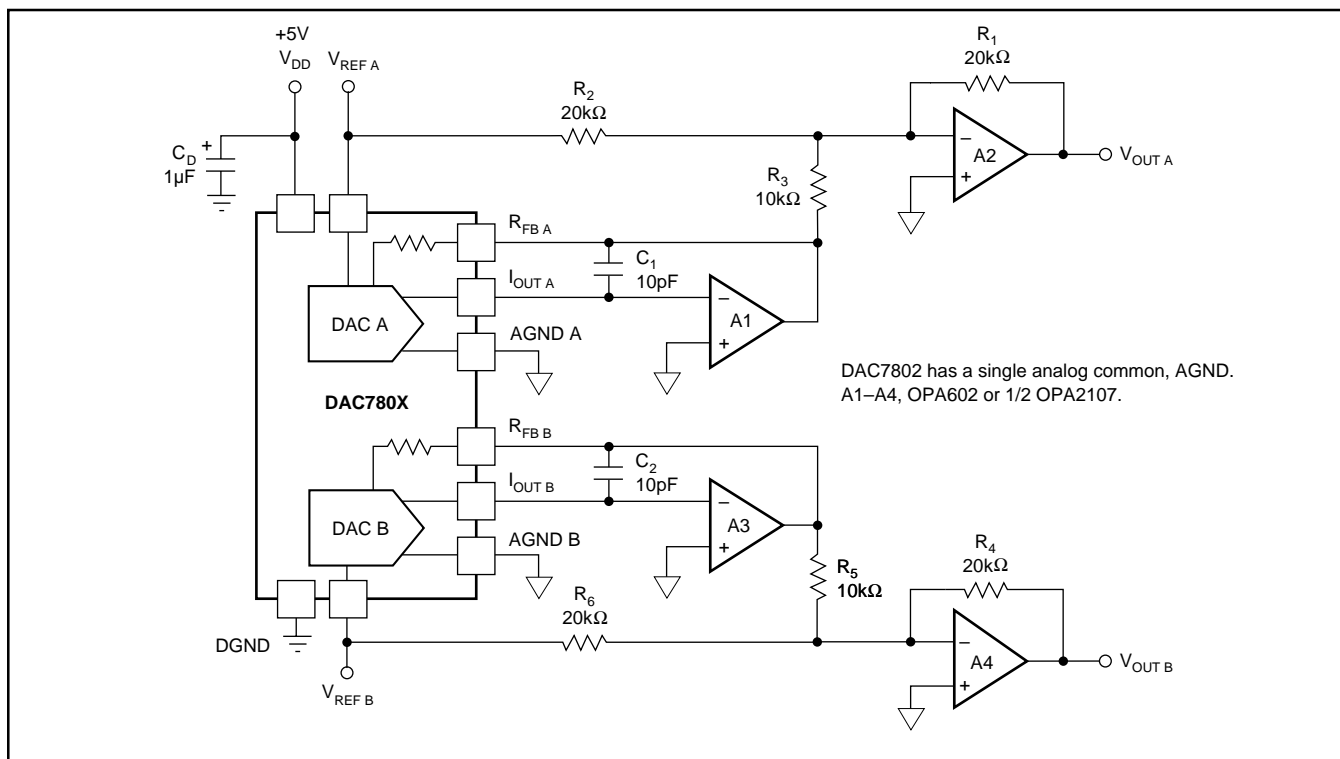

FIGURE 5. Bipolar Configuration.

## APPLICATIONS

### 12-BIT PLUS SIGN DACS

For a bipolar DAC with 13 bits of resolution, two solutions are possible. The addition of a precision difference amplifier and a high speed JFET switch provides a 12-bit plus sign voltage-output DAC, see Figure 7. When the switch selects the op amp output, the difference amplifier serves as a noninverting output buffer. If the analog ground side of the switch is selected, the output of the difference amplifier is inverted.

Another option, see Figure 8, also produces a 12-bit plus sign output without the additional switch and digital control line.

### DIGITALLY PROGRAMMABLE ACTIVE FILTER

See Figure 9 for the DAC780x in a digitally programmable active filter application. The design is based on the state-variable filter, Texas Instruments UAF42, an active filter topology that offers stable and repeatable filter characteristics.

DAC1 and DAC2 can be updated in parallel with a single word to set the center frequency of the filter. DAC 4, which makes use of the uncommitted op amp in UAF42, sets the Q of the filter. DAC3 sets the gain of the filter transfer function without changing the Q of the filter. The reverse is also true.

The center frequency is determined by  $f_c = 1/2\pi RC$  where R is the ladder resistance of the DAC (typical value, 10kΩ) and C the internal capacitor value (1000pF) of the UAF42. External capacitors can be added to lower the center frequency of the filter. But the highest center frequency for this circuit will be about 16kHz because the effective series resistance of the DAC cannot be less than 10kΩ.

Note that the ladder resistance of the DAC may vary from device to device. Thus, for best tracking, DAC2 and DAC3 should be in the same package. Some calibration may be necessary from one filter to another.

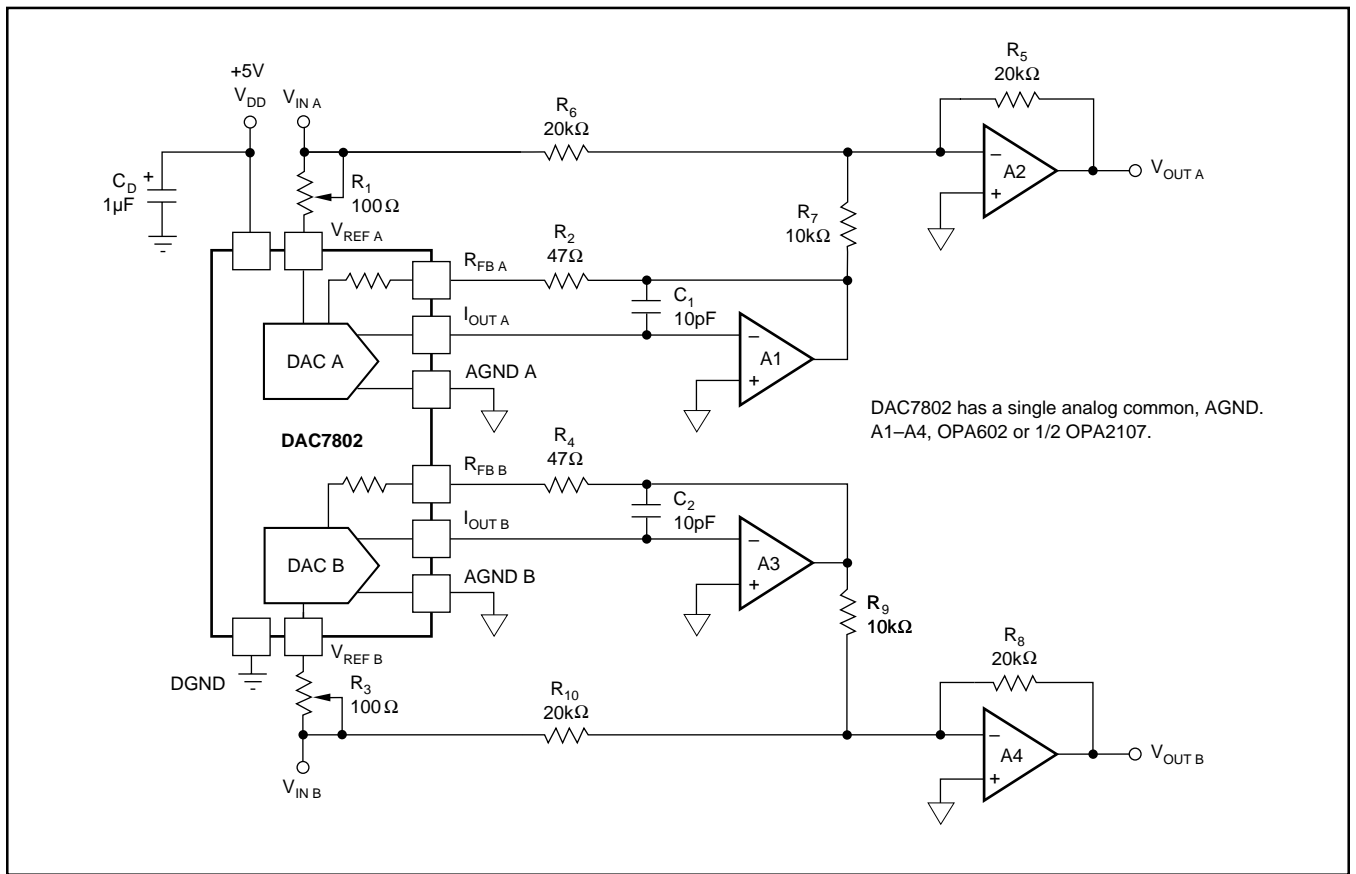

FIGURE 6. Bipolar Configuration with Gain Trim.

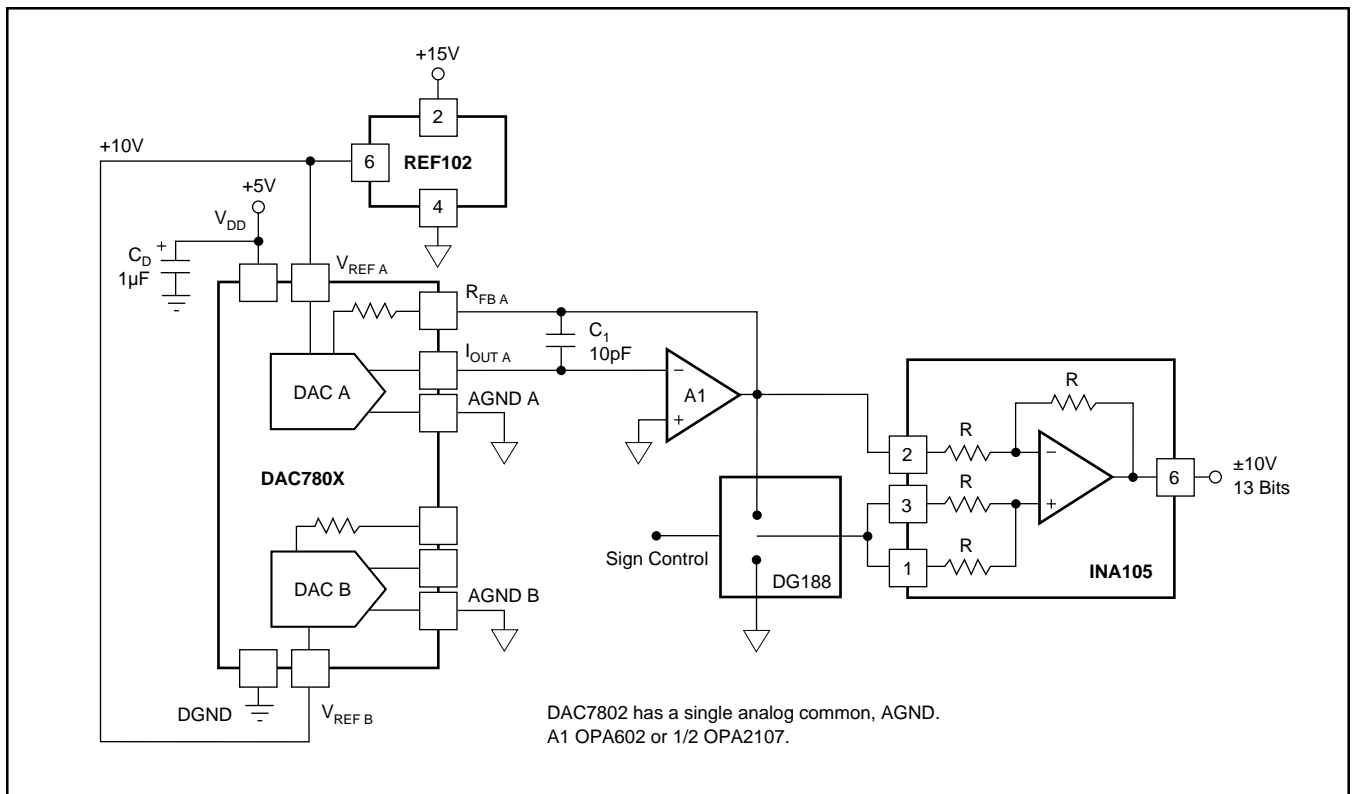

FIGURE 7. 12-Bit Plus Sign DAC.

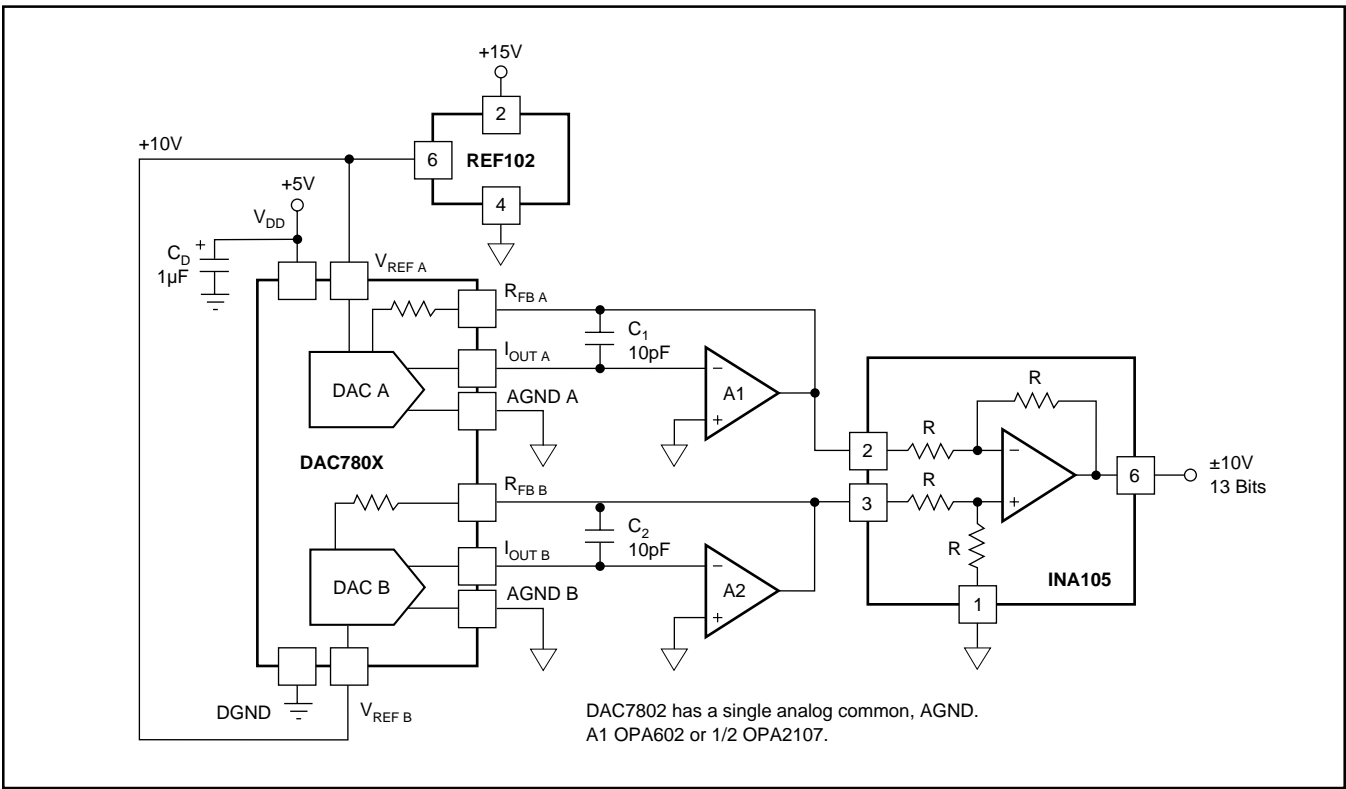

FIGURE 8. 13-Bit Bipolar DAC.

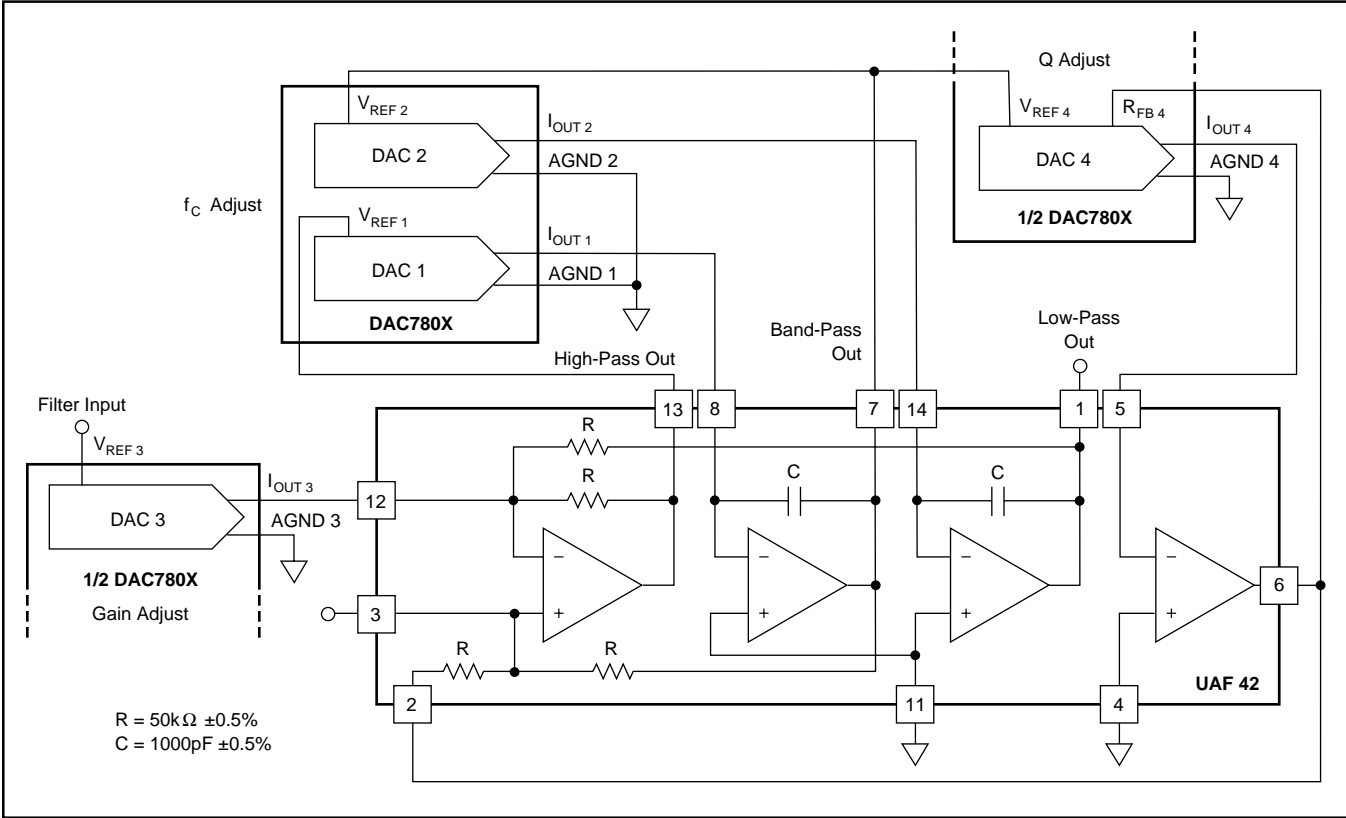

FIGURE 9. Digitally Programmable Universal Active Filter.

**PACKAGING INFORMATION**

Orderable Device	Status (1)	Package Type	Package Drawing	Pins	Package Qty	Eco Plan (2)	Lead/Ball Finish (6)	MSL Peak Temp (3)	Op Temp (°C)	Device Marking (4/5)	Samples
DAC7800KU	ACTIVE	SOIC	DW	16	40	Green (RoHS & no Sb/Br)	NIPDAU	Level-3-260C-168 HR	-40 to 85	DAC7800KU	<a href="#">Samples</a>
DAC7800KU/1K	ACTIVE	SOIC	DW	16	1000	Green (RoHS & no Sb/Br)	NIPDAU	Level-3-260C-168 HR	-40 to 85	DAC7800KU	<a href="#">Samples</a>
DAC7800KU/1KG4	ACTIVE	SOIC	DW	16	1000	Green (RoHS & no Sb/Br)	NIPDAU	Level-3-260C-168 HR	-40 to 85	DAC7800KU	<a href="#">Samples</a>
DAC7800LP	NRND	PDIP	N	16	25	Green (RoHS & no Sb/Br)	NIPDAU	N / A for Pkg Type	-40 to 85	DAC7800LP	
DAC7800LPG4	NRND	PDIP	N	16	25	Green (RoHS & no Sb/Br)	NIPDAU	N / A for Pkg Type	-40 to 85	DAC7800LP	
DAC7800LU	NRND	SOIC	DW	16	40	Green (RoHS & no Sb/Br)	NIPDAU	Level-3-260C-168 HR	-40 to 85	DAC7800LU	
DAC7801KU	ACTIVE	SOIC	DW	24	25	Green (RoHS & no Sb/Br)	NIPDAU	Level-3-260C-168 HR	-40 to 85	DAC7801KU	<a href="#">Samples</a>
DAC7801KU/1K	ACTIVE	SOIC	DW	24	1000	Green (RoHS & no Sb/Br)	NIPDAU	Level-3-260C-168 HR	-40 to 85	DAC7801KU	<a href="#">Samples</a>
DAC7801LU	ACTIVE	SOIC	DW	24	25	Green (RoHS & no Sb/Br)	NIPDAU	Level-3-260C-168 HR	-40 to 85	DAC7801LU	<a href="#">Samples</a>
DAC7802KU	ACTIVE	SOIC	DW	24	25	Green (RoHS & no Sb/Br)	NIPDAU	Level-3-260C-168 HR	-40 to 85	DAC7802KU	<a href="#">Samples</a>
DAC7802KU/1K	ACTIVE	SOIC	DW	24	1000	Green (RoHS & no Sb/Br)	NIPDAU	Level-3-260C-168 HR	-40 to 85	DAC7802KU	<a href="#">Samples</a>
DAC7802LU	ACTIVE	SOIC	DW	24	25	Green (RoHS & no Sb/Br)	NIPDAU	Level-3-260C-168 HR	-40 to 85	DAC7802LU	<a href="#">Samples</a>
DAC7802LUG4	ACTIVE	SOIC	DW	24	25	Green (RoHS & no Sb/Br)	NIPDAU	Level-3-260C-168 HR	-40 to 85	DAC7802LU	<a href="#">Samples</a>

(1) The marketing status values are defined as follows:

**ACTIVE:** Product device recommended for new designs.

**LIFEBUY:** TI has announced that the device will be discontinued, and a lifetime-buy period is in effect.

**NRND:** Not recommended for new designs. Device is in production to support existing customers, but TI does not recommend using this part in a new design.

**PREVIEW:** Device has been announced but is not in production. Samples may or may not be available.

**OBSELETE:** TI has discontinued the production of the device.

(2) **RoHS:** TI defines "RoHS" to mean semiconductor products that are compliant with the current EU RoHS requirements for all 10 RoHS substances, including the requirement that RoHS substance do not exceed 0.1% by weight in homogeneous materials. Where designed to be soldered at high temperatures, "RoHS" products are suitable for use in specified lead-free processes. TI may reference these types of products as "Pb-Free".

**RoHS Exempt:** TI defines "RoHS Exempt" to mean products that contain lead but are compliant with EU RoHS pursuant to a specific EU RoHS exemption.

**Green:** TI defines "Green" to mean the content of Chlorine (Cl) and Bromine (Br) based flame retardants meet JS709B low halogen requirements of  $\leq 1000$ ppm threshold. Antimony trioxide based flame retardants must also meet the  $\leq 1000$ ppm threshold requirement.

(3) MSL, Peak Temp. - The Moisture Sensitivity Level rating according to the JEDEC industry standard classifications, and peak solder temperature.

(4) There may be additional marking, which relates to the logo, the lot trace code information, or the environmental category on the device.

(5) Multiple Device Markings will be inside parentheses. Only one Device Marking contained in parentheses and separated by a "~" will appear on a device. If a line is indented then it is a continuation of the previous line and the two combined represent the entire Device Marking for that device.

(6) Lead/Ball Finish - Orderable Devices may have multiple material finish options. Finish options are separated by a vertical ruled line. Lead/Ball Finish values may wrap to two lines if the finish value exceeds the maximum column width.

**Important Information and Disclaimer:** The information provided on this page represents TI's knowledge and belief as of the date that it is provided. TI bases its knowledge and belief on information provided by third parties, and makes no representation or warranty as to the accuracy of such information. Efforts are underway to better integrate information from third parties. TI has taken and continues to take reasonable steps to provide representative and accurate information but may not have conducted destructive testing or chemical analysis on incoming materials and chemicals. TI and TI suppliers consider certain information to be proprietary, and thus CAS numbers and other limited information may not be available for release.

In no event shall TI's liability arising out of such information exceed the total purchase price of the TI part(s) at issue in this document sold by TI to Customer on an annual basis.

## TAPE AND REEL INFORMATION



### QUADRANT ASSIGNMENTS FOR PIN 1 ORIENTATION IN TAPE



\*All dimensions are nominal

Device	Package Type	Package Drawing	Pins	SPQ	Reel Diameter (mm)	Reel Width W1 (mm)	A0 (mm)	B0 (mm)	K0 (mm)	P1 (mm)	W (mm)	Pin1 Quadrant
DAC7800KU/1K	SOIC	DW	16	1000	330.0	16.4	10.75	10.7	2.7	12.0	16.0	Q1
DAC7801KU/1K	SOIC	DW	24	1000	330.0	24.4	10.75	15.7	2.7	12.0	24.0	Q1
DAC7802KU/1K	SOIC	DW	24	1000	330.0	24.4	10.75	15.7	2.7	12.0	24.0	Q1

## TAPE AND REEL BOX DIMENSIONS



\*All dimensions are nominal

Device	Package Type	Package Drawing	Pins	SPQ	Length (mm)	Width (mm)	Height (mm)
DAC7800KU/1K	SOIC	DW	16	1000	350.0	350.0	43.0
DAC7801KU/1K	SOIC	DW	24	1000	350.0	350.0	43.0
DAC7802KU/1K	SOIC	DW	24	1000	350.0	350.0	43.0



DW (R-PDSO-G24)

PLASTIC SMALL OUTLINE



- NOTES:
- A. All linear dimensions are in inches (millimeters). Dimensioning and tolerancing per ASME Y14.5M-1994.
  - B. This drawing is subject to change without notice.
  - C. Body dimensions do not include mold flash or protrusion not to exceed 0.006 (0,15).
  - D. Falls within JEDEC MS-013 variation AD.

DW (R-PDSO-G24)

PLASTIC SMALL OUTLINE

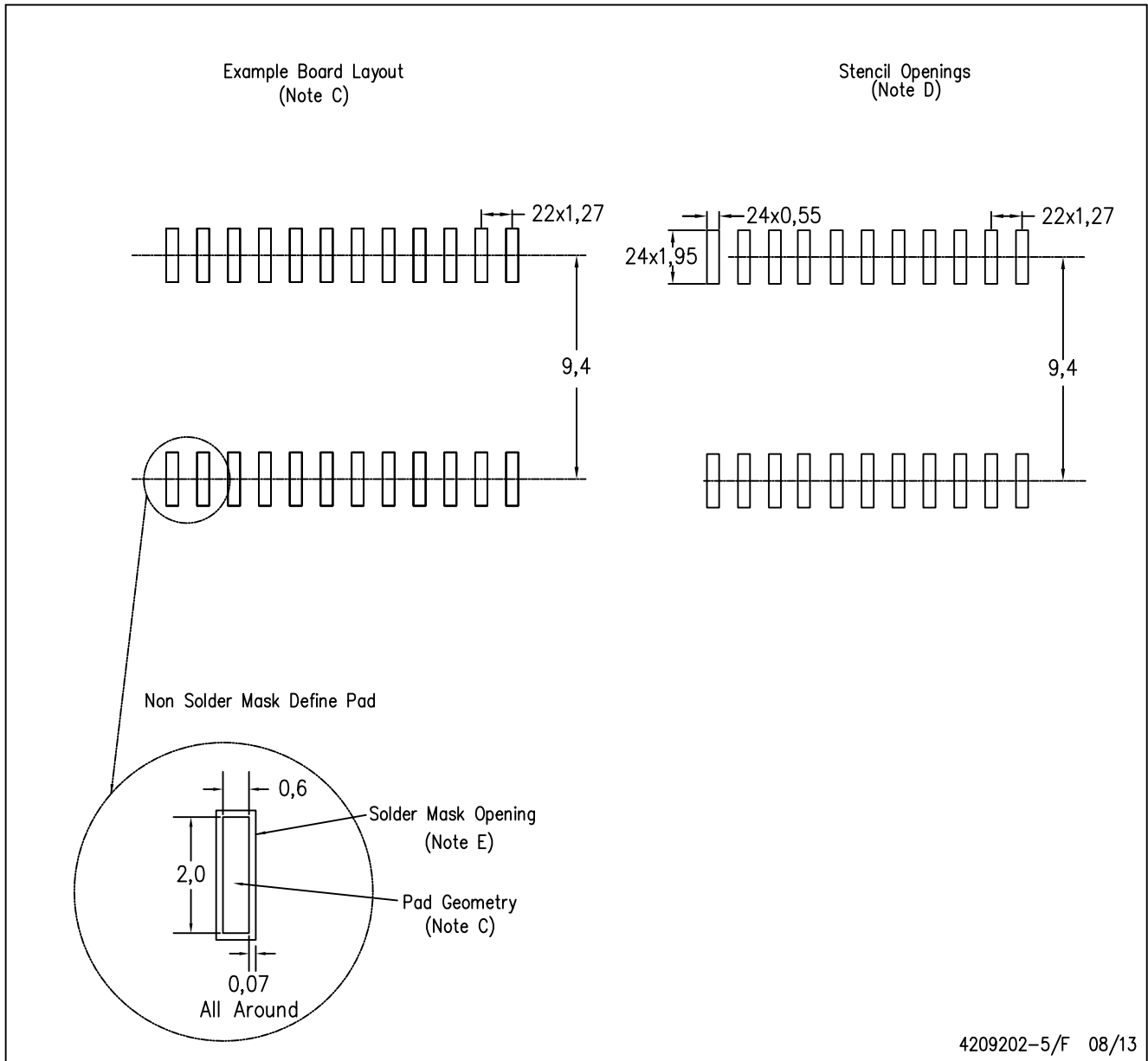

4209202-5/F 08/13

- NOTES:
- A. All linear dimensions are in millimeters.
  - B. This drawing is subject to change without notice.
  - C. Refer to IPC7351 for alternate board design.
  - D. Laser cutting apertures with trapezoidal walls and also rounding corners will offer better paste release. Customers should contact their board assembly site for stencil design recommendations. Refer to IPC-7525
  - E. Customers should contact their board fabrication site for solder mask tolerances between and around signal pads.

## GENERIC PACKAGE VIEW

**DW 16**

**SOIC - 2.65 mm max height**

7.5 x 10.3, 1.27 mm pitch

SMALL OUTLINE INTEGRATED CIRCUIT

This image is a representation of the package family, actual package may vary.  
Refer to the product data sheet for package details.



4224780/A



DW0016A

# PACKAGE OUTLINE

SOIC - 2.65 mm max height

SOIC

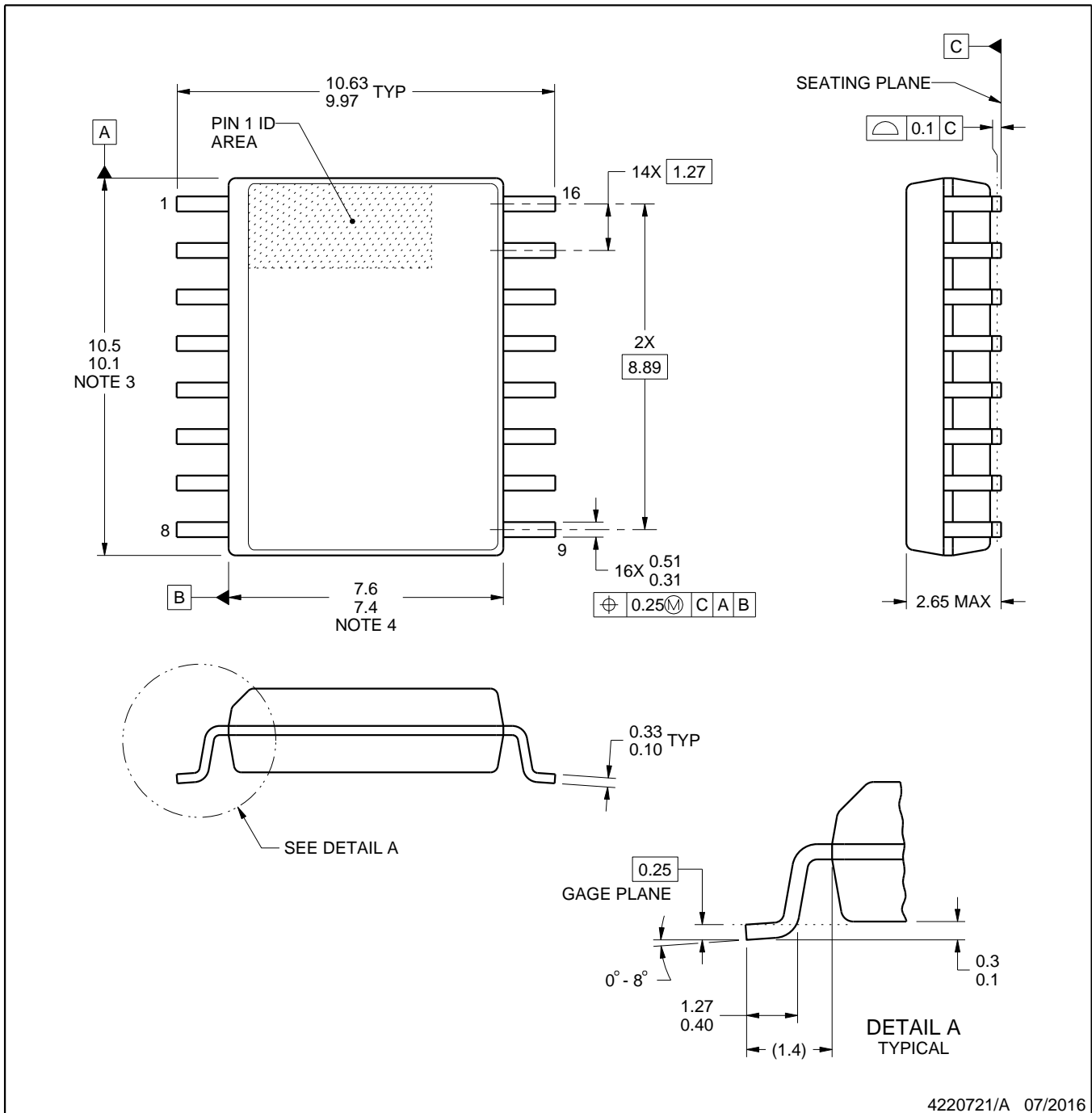

4220721/A 07/2016

NOTES:

1. All linear dimensions are in millimeters. Dimensions in parenthesis are for reference only. Dimensioning and tolerancing per ASME Y14.5M.
2. This drawing is subject to change without notice.
3. This dimension does not include mold flash, protrusions, or gate burrs. Mold flash, protrusions, or gate burrs shall not exceed 0.15 mm, per side.
4. This dimension does not include interlead flash. Interlead flash shall not exceed 0.25 mm, per side.
5. Reference JEDEC registration MS-013.

# EXAMPLE BOARD LAYOUT

DW0016A

SOIC - 2.65 mm max height

SOIC



LAND PATTERN EXAMPLE  
SCALE:7X



SOLDER MASK DETAILS

4220721/A 07/2016

NOTES: (continued)

6. Publication IPC-7351 may have alternate designs.

7. Solder mask tolerances between and around signal pads can vary based on board fabrication site.

# EXAMPLE STENCIL DESIGN

DW0016A

SOIC - 2.65 mm max height

SOIC



SOLDER PASTE EXAMPLE  
BASED ON 0.125 mm THICK STENCIL  
SCALE:7X

4220721/A 07/2016

NOTES: (continued)

8. Laser cutting apertures with trapezoidal walls and rounded corners may offer better paste release. IPC-7525 may have alternate design recommendations.
9. Board assembly site may have different recommendations for stencil design.

N (R-PDIP-T\*\*)

PLASTIC DUAL-IN-LINE PACKAGE

16 PINS SHOWN



- NOTES:
- A. All linear dimensions are in inches (millimeters).
  - B. This drawing is subject to change without notice.
  - Falls within JEDEC MS-001, except 18 and 20 pin minimum body length (Dim A).
  - The 20 pin end lead shoulder width is a vendor option, either half or full width.

## IMPORTANT NOTICE AND DISCLAIMER

TI PROVIDES TECHNICAL AND RELIABILITY DATA (INCLUDING DATASHEETS), DESIGN RESOURCES (INCLUDING REFERENCE DESIGNS), APPLICATION OR OTHER DESIGN ADVICE, WEB TOOLS, SAFETY INFORMATION, AND OTHER RESOURCES "AS IS" AND WITH ALL FAULTS, AND DISCLAIMS ALL WARRANTIES, EXPRESS AND IMPLIED, INCLUDING WITHOUT LIMITATION ANY IMPLIED WARRANTIES OF MERCHANTABILITY, FITNESS FOR A PARTICULAR PURPOSE OR NON-INFRINGEMENT OF THIRD PARTY INTELLECTUAL PROPERTY RIGHTS.

These resources are intended for skilled developers designing with TI products. You are solely responsible for (1) selecting the appropriate TI products for your application, (2) designing, validating and testing your application, and (3) ensuring your application meets applicable standards, and any other safety, security, or other requirements. These resources are subject to change without notice. TI grants you permission to use these resources only for development of an application that uses the TI products described in the resource. Other reproduction and display of these resources is prohibited. No license is granted to any other TI intellectual property right or to any third party intellectual property right. TI disclaims responsibility for, and you will fully indemnify TI and its representatives against, any claims, damages, costs, losses, and liabilities arising out of your use of these resources.

TI's products are provided subject to TI's Terms of Sale ([www.ti.com/legal/termsofsale.html](http://www.ti.com/legal/termsofsale.html)) or other applicable terms available either on [ti.com](http://ti.com) or provided in conjunction with such TI products. TI's provision of these resources does not expand or otherwise alter TI's applicable warranties or warranty disclaimers for TI products.

Mailing Address: Texas Instruments, Post Office Box 655303, Dallas, Texas 75265  
Copyright © 2020, Texas Instruments Incorporated