

CONNECTOR DESIGNATORS
A-F-H-L-S
ROTATABLE COUPLING

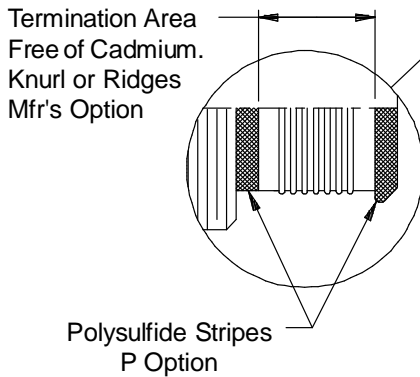

Ultra Low-Profile Split 90°

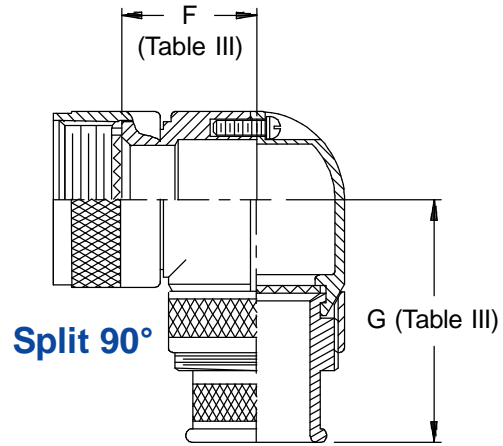
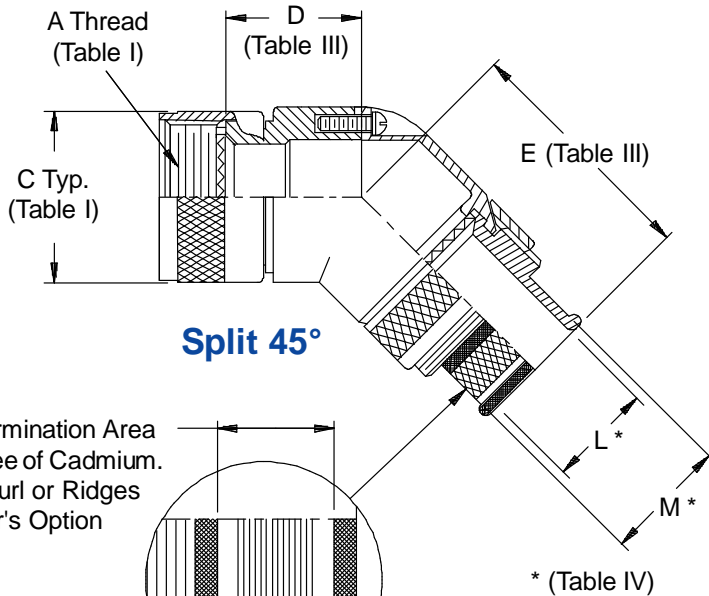
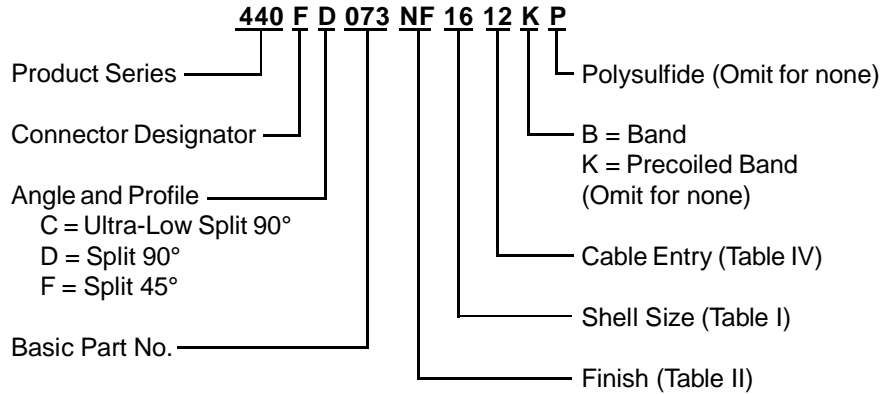
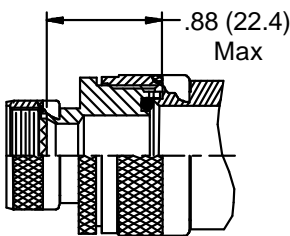
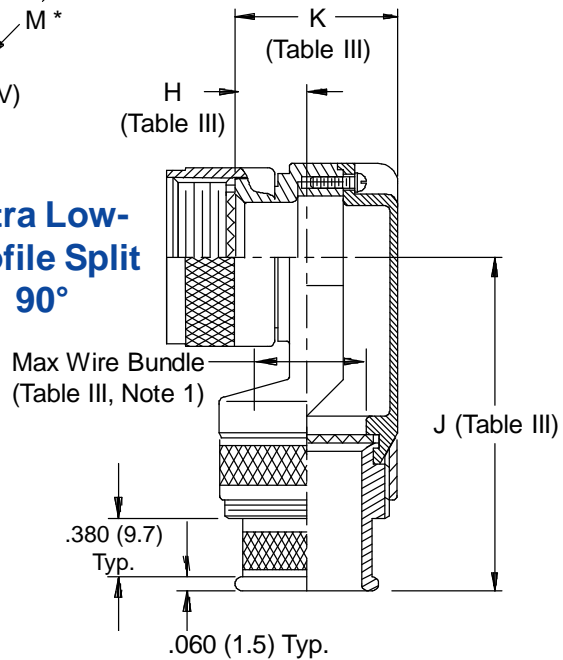

STYLE 2
(See Note 1)

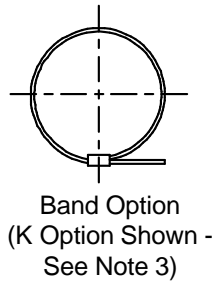

See inside back cover fold-out or pages 13 and 14 for Tables I and II.

TABLE III: ELBOW DIMENSIONS

Shell Size	D Max	E Max	F Max	G Max	H Max	J Max	K Max	Function C Max Wire Bundle
08/09	.440 (11.2)	1.590 (40.4)	.680 (17.3)	1.530 (38.9)	.340 (8.6)	1.870 (47.5)	.681 (17.3)	.250 (6.4)
10/11	.500 (12.7)	1.650 (41.9)	.750 (19.1)	1.590 (40.4)	.270 (6.9)	2.030 (51.6)	.731 (18.6)	.375 (9.5)
12/13	.560 (14.2)	1.720 (43.7)	.810 (20.6)	1.660 (42.2)	.270 (6.9)	2.030 (51.6)	.731 (18.6)	.375 (9.5)
14/15	.620 (15.7)	1.750 (44.5)	.870 (22.1)	1.690 (42.9)	.280 (7.1)	2.100 (53.3)	.831 (21.1)	.500 (12.7)
16/17	.680 (17.3)	1.850 (47.0)	.930 (23.6)	1.790 (45.5)	.420 (10.7)	2.150 (54.6)	.981 (24.9)	.625 (15.9)
18/19	.750 (19.1)	1.910 (48.5)	1.000 (25.4)	1.850 (47.0)	.640 (16.3)	2.180 (55.4)	1.181 (30.0)	.625 (15.9)
20/21	.820 (20.8)	1.970 (50.0)	1.060 (26.9)	1.910 (48.5)	.640 (16.3)	2.180 (55.4)	1.181 (30.0)	.625 (15.9)
22/23	.880 (22.4)	2.030 (51.6)	1.120 (28.4)	1.970 (50.0)	.540 (13.7)	2.330 (59.2)	1.181 (30.0)	.750 (19.1)
24/25	.940 (23.9)	2.090 (53.1)	1.180 (30.0)	2.030 (51.6)	.540 (13.7)	2.330 (59.2)	1.181 (30.0)	.750 (19.1)

TABLE IV: CABLE ENTRY

Dash No.	L Dia	M Dia
02	.125 (3.2)	.250 (6.4)
03	.188 (4.8)	.312 (7.9)
04	.250 (6.4)	.375 (9.5)
05	.312 (7.9)	.438 (11.1)
06	.375 (9.5)	.500 (12.7)
07	.438 (11.1)	.562 (14.3)
08	.500 (12.7)	.625 (15.9)
09	.562 (14.3)	.688 (17.5)
10	.625 (15.9)	.750 (19.1)
11	.688 (17.5)	.812 (20.6)
12	.750 (19.1)	.875 (22.2)
13	.812 (20.6)	.938 (23.8)
14	.875 (22.2)	1.000 (25.4)
15	.938 (23.8)	1.062 (27.0)
16	1.000 (25.4)	1.125 (28.6)
17	1.062 (27.0)	1.188 (30.2)
18	1.125 (28.6)	1.250 (31.8)
20	1.250 (31.8)	1.375 (34.9)
22	1.375 (34.9)	1.500 (38.1)
24	1.500 (38.1)	1.625 (41.3)

1. When maximum cable entry (page 21) is exceeded, Style 2 will be supplied (not available on Function C). Dimensions D, E, F and G will not apply. Please consult factory.
2. Metric dimensions (mm) are indicated in parentheses.
3. Backshells supplied with 600-052-* band, see Glenair Series 600 Tool Catalog for installation.
4. Angular function "C", low-profile split elbow, not available with "S" connector designator.

Mouser Electronics

Authorized Distributor

Click to View Pricing, Inventory, Delivery & Lifecycle Information:

[Glenair:](#)

[440FC073NF1408K](#) [440HC073NF1304](#) [440HC073NF1709](#)