



FCIconnect.com

Copyright FCI.

1

2

List of "HFW__R-5/6STE1LF" customer document

DOCUMENT NO.	LIST
SC-HFWR05	SPEC.
JSA97339	CAT.NO.TABLE FOR 1mm SPACING SMT CONNECTOR (HFW__R-5/6ST_LF)
JSA97340	1mm SPACING SURFACE MOUNT CIC CONNECCTOR (HFW__R-5ST_LF)
JSA97341	1mm SPACING SURFACE MOUNT CIC CONNECCTOR (HFW__R-6ST_LF)
JSA97342	CAT.NO.TABLE FOR PLASTIC TAPE PACKAGED 1mm SPACING SMT CONN.(HFW__R-5/6STE1LF)
JSA97343	1mm SPACING SMT CONNECTOR (HFW__R-5STE1LF)
JSA97344	1mm SPACING SMT CONNECTOR (HFW__R-6STE1LF)
JSA97345	RECOMMENDED CABLE (CIC) (HFW__R-5/6___)

mat'l. code		surface 58 ISO 1302 ✓		tolerance ISO 406 ISO 1101		projection 		product family 58NF		CODE JP	
ltr	ecn no	dr	date	tolerances unless otherwise specified		mm 		title 1mm SPACING CIC CONNECTOR DOCUMENT LIST (Cat. No. : HFW__R-5/6STE1LF)			
A	J07-0397	H.T	7/27/07	angles	linear	scale X		dwg no JSA 97346		sheet 1 of 1 size A4	
sheet index		revision sheet		dr engr chr appd				type Product Customer Drawing			
		A		7/27/07 7/29/07 7/27/07 7/27/07						Rev A	

form: A4

1

2

CAT. NO. & DIMENSIONS

(NOTE3)	NO. OF CONTACTS (n)	CAT. NO.	DIMENSIONS (NOTE2)		
			A ± 0.2	B ± 0.2	C ± 0.1
	4	HFW4R-5/6ST__LF	6.6	3	5.14
	5	HFW5R-5/6ST__LF	7.6	4	6.14
	6	HFW6R-5/6ST__LF	8.6	5	7.14
	7	HFW7R-5/6ST__LF	9.6	6	8.14
	8	HFW8R-5/6ST__LF	10.6	7	9.14
	9	HFW9R-5/6ST__LF	11.6	8	10.14
	10	HFW10R-5/6ST__LF	12.6	9	11.14
	11	HFW11R-5/6ST__LF	13.6	10	12.14
	12	HFW12R-5/6ST__LF	14.6	11	13.14
	13	HFW13R-5/6ST__LF	15.6	12	14.14
	14	HFW14R-5/6ST__LF	16.6	13	15.14
	15	HFW15R-5/6ST__LF	17.6	14	16.14
	16	HFW16R-5/6ST__LF	18.6	15	17.14
	17	HFW17R-5/6ST__LF	19.6	16	18.14
	18	HFW18R-5/6ST__LF	20.6	17	19.14
	19	HFW19R-5/6ST__LF	21.6	18	20.14
	20	HFW20R-5/6ST__LF	22.6	19	21.14
	21	HFW21R-5/6ST__LF	23.6	20	22.14
	22	HFW22R-5/6ST__LF	24.6	21	23.14
	23	HFW23R-5/6ST__LF	25.6	22	24.14
	24	HFW24R-5/6ST__LF	26.6	23	25.14
	25	HFW25R-5/6ST__LF	27.6	24	26.14
	26	HFW26R-5/6ST__LF	28.6	25	27.14
	27	HFW27R-5/6ST__LF	29.6	26	28.14
*	28	HFW28R-5/6ST__LF	30.6	27	29.14
*	29	HFW29R-5/6ST__LF	31.6	28	30.14
	30	HFW30R-5/6ST__LF	32.6	29	31.14

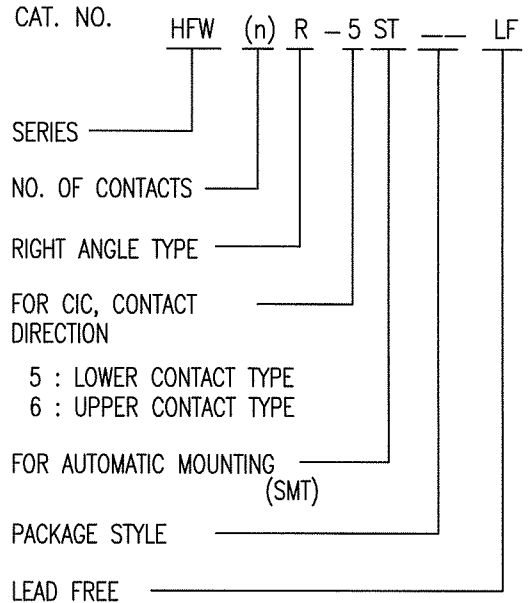

NOTES

1. THIS PRODUCT IS THE CONNECTOR DESIGNED TO TERMINATE CIC AND COPES WITH AUTOMATIC MOUNTING (SMT).
2. SEE PART DRAWINGS FOR DIMENSIONS A~C.
3. PLEASE CONSULT US IN CASE OF USING PARTS WITH * MARK.

mat'l. code		surface 58 / tolerance ISO 1302 ✓ / ISO 406 / ISO 1101		projection		product family 58NF		CODE JP	
ltr	ecn no	dr	date	tolerances unless otherwise specified		title		sheet 1 of 1 size	
A	J07-0397	H.T.	7/27/07	angles	linear	CAT. NO. TABLE FOR 1mm SPACING SMT CONNECTOR (Cat. No. HFW__R-5/6ST__LF)		A4	
				dr	7/27/07	dwg no JSA 97339			
				enr	7/27/07	type Product Customer Drawing			
				chr	7/27/07				
				app	7/27/07				
sheet index		revision A						Rev. A	
		sheet 1							

SC-HFWR05 form: A4 JSA97340 97341 97342 97343 97344 97345

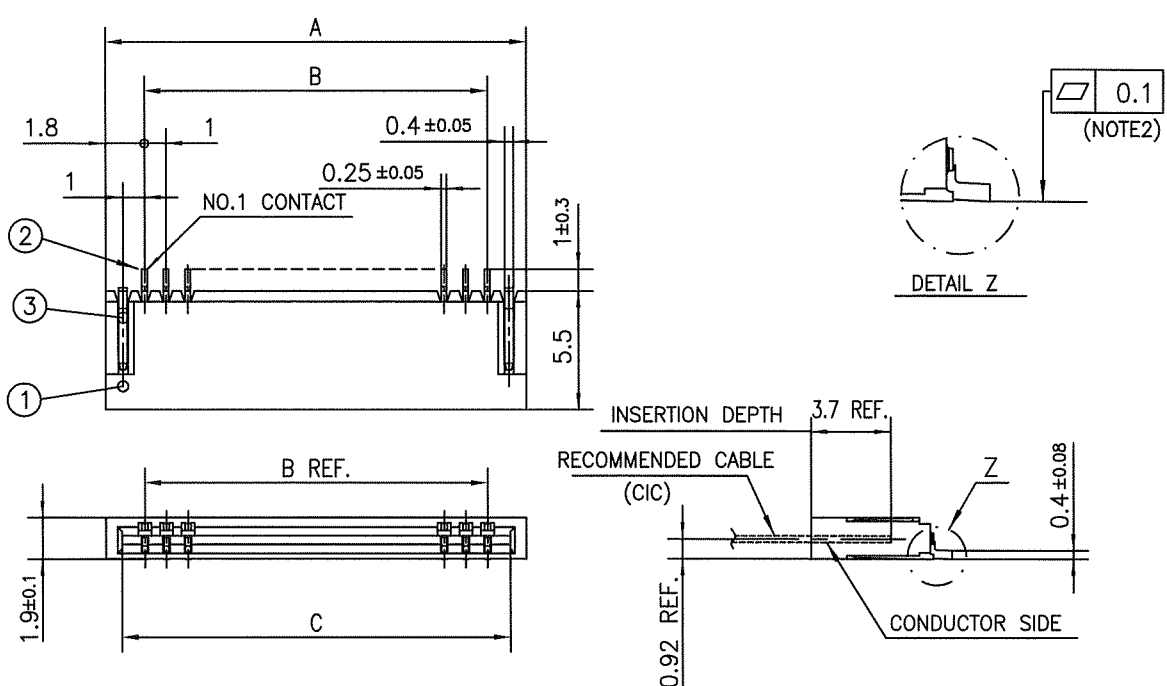

PT. NO.	PARTS NAME	MATERIAL	Q'TY	NOTE
1	HOUSING	PA6T RESIN GLASS REINFORCED (UL94V-0)	1	COLOR:BLACK
2	CONTACT	PHOSPHOR BRONZE	n	PLATING:TIN
3	MOUNTING PLATE		2	(LEAD FREE)

n : NO. OF CONTACTS

NOTES

1. THIS PRODUCT IS THE CONNECTOR DESIGNED TO TERMINATE CIC AND COPE WITH AUTOMATIC MOUNTING (SMT).
2. FLATNESS OF CONTACT TERMINAL FOR HOUSING MUST BE WITHIN TOLERANCE IN Z PORTION DETAILED DRAWING.
3. THIS PRODUCT IS LOWER CONTACT TYPE CONNECTOR.
4. THIS PRODUCT MEETS EUROPEAN UNION DIRECTIVES AND OTHER COUNTRY REGULATIONS AS DESCRIBED IN GS-22-008
5. THE HOUSING WILL WITHSTAND EXPOSURE TO 260°C PEAK TEMPERATURE FOR 10 SECONDS IN A REFLOW SOLDERING OVEN.

RECOMMENDED PC BOARD LAYOUT (COMPONENT SIDE)

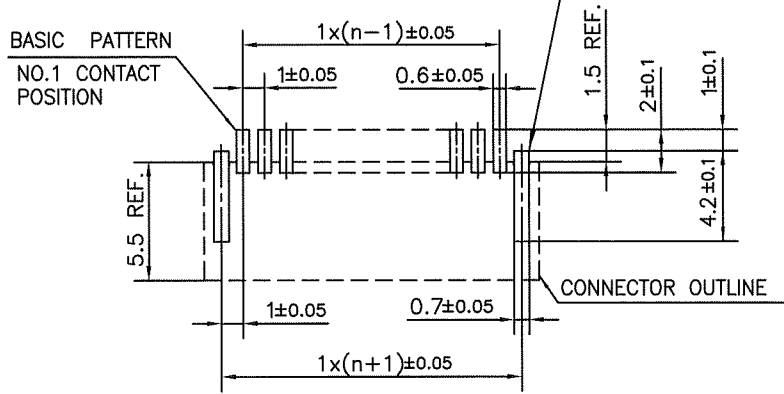

mat'l. code		surface 58 / tolerance ISO 1302 ✓ / ISO 406 / ISO 1101		projection	product family 58NF	CODE JP	
ltr	ecn no	dr	date	tolerances, unless otherwise specified ±0.2	title 1mm SPACING SURFACE MOUNT CIC CONNECTOR (Cat.No. HFW__R-5ST__LF)		
A	J07-0397	H.T	7/27/07	angles linear	mm		
				dr	scale X		
				enr	dwg no sheet 1 of 1 size		
				chr	JSA 97340 A4		
				app	type Product Customer Drawing		
sheet index	revision sheet	A	1				Rev A

SC-HFWR JSA97339 Form: A4



FCIconnect.com

Copyright FCI.



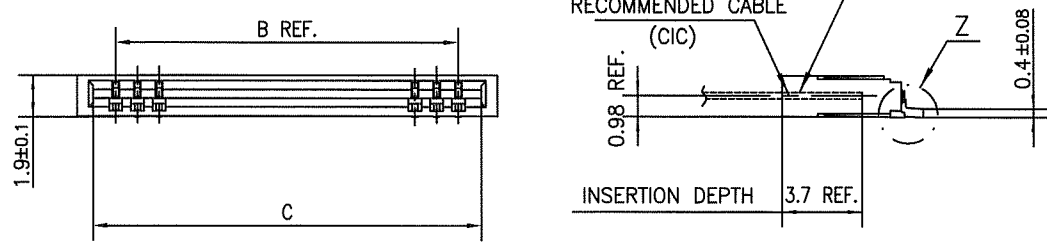
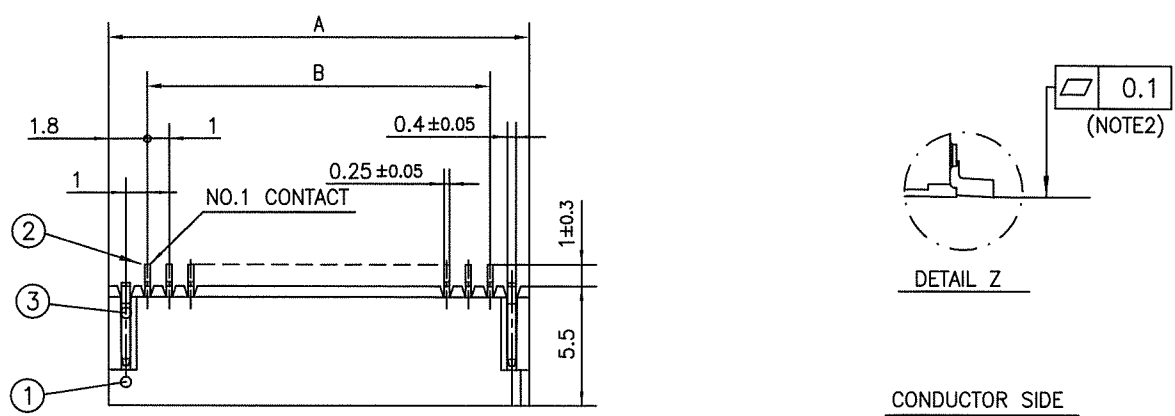

PT. NO.	PARTS NAME	MATERIAL	Q'TY	NOTE
1	HOUSING	PA6T RESIN GLASS REINFORCED (UL94V-0)	1	COLOR:BLACK
2	CONTACT	PHOSPHOR BRONZE	n	PLATING:TIN
3	MOUNTING PLATE		2	(LEAD FREE)

n : NO. OF CONTACTS

RECOMMENDED PC BOARD LAYOUT
(COMPONENT SIDE)

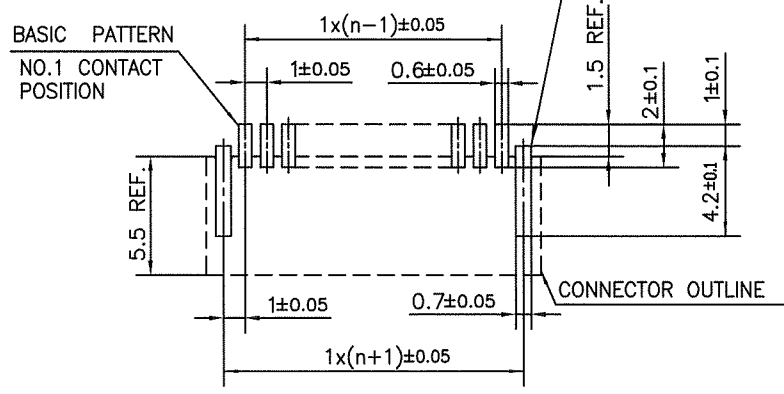

NOTES

1. THIS PRODUCT IS THE CONNECTOR DESIGNED TO TERMINATE CIC AND COPE WITH AUTOMATIC MOUNTING (SMT).
2. FLATNESS OF CONTACT TERMINAL FOR HOUSING MUST BE WITHIN TOLERANCE IN Z PORTION DETAILED DRAWING.
3. THIS PRODUCT IS UPPER CONTACT TYPE CONNECTOR.
4. THIS PRODUCT MEETS EUROPEAN UNION DIRECTIVES AND OTHER COUNTRY REGULATIONS AS DESCRIBED IN GS-22-008
5. THE HOUSING WILL WITHSTAND EXPOSURE TO 260°C PEAK TEMPERATURE FOR 10 SECONDS IN A REFLOW SOLDERING OVEN.

mat'l. code		surface 58 / tolerance ISO 1302 ✓ / ISO 406 / ISO 1101		projection	product family 58NF	CODE JP
ltr	ecn no	dr	date	mm	title 1mm SPACING SURFACE MOUNT CIC CONNECTOR (Cat. No. HFWR__R-6ST__LF)	
A	J07-0397	H.T.	7/27/07			
		tolerances unless otherwise specified		scale X	dwg no sheet 1 of 1 size JSA 97341 A4	
		angles	linear ±0.2			
		dr	<i>H. Sudo</i> 7/27/07		type Product Customer Drawing	
		enr	<i>H. Sudo</i> 7/27/07			
		chr	<i>R. Sudo</i> 7/27/07			
		app	<i>S. Sudo</i> 7/27/07			
sheet index	revision	A				Rev. A
	sheet	1				

SC-HFWR05 JSA97339
form: A4

FCI
 FCconnect.com
 Copyright FCI.

CAT. NO. & DIMENSIONS

(NOTE4)	NO. OF CONTACTS (n)	CAT. NO. (NOTE2)	DIMENSIONS (NOTE3)		
			E ± 5	F ± 0.3	G ± 0.1
	4	HFW4R-5/6STE1LF	28.4	24	—
	5	HFW5R-5/6STE1LF	28.4	24	—
	6	HFW6R-5/6STE1LF	28.4	24	—
	7	HFW7R-5/6STE1LF	28.4	24	—
	8	HFW8R-5/6STE1LF	28.4	24	—
	9	HFW9R-5/6STE1LF	28.4	24	—
	10	HFW10R-5/6STE1LF	28.4	24	—
	11	HFW11R-5/6STE1LF	28.4	24	—
	12	HFW12R-5/6STE1LF	28.4	24	—
	13	HFW13R-5/6STE1LF	28.4	24	—
	14	HFW14R-5/6STE1LF	28.4	24	—
	15	HFW15R-5/6STE1LF	36.4	32	28.4
	16	HFW16R-5/6STE1LF	36.4	32	28.4
	17	HFW17R-5/6STE1LF	36.4	32	28.4
	18	HFW18R-5/6STE1LF	36.4	32	28.4
	19	HFW19R-5/6STE1LF	48.4	44	40.4
	20	HFW20R-5/6STE1LF	48.4	44	40.4
	21	HFW21R-5/6STE1LF	48.4	44	40.4
	22	HFW22R-5/6STE1LF	48.4	44	40.4
	23	HFW23R-5/6STE1LF	48.4	44	40.4
	24	HFW24R-5/6STE1LF	48.4	44	40.4
	25	HFW25R-5/6STE1LF	48.4	44	40.4
	26	HFW26R-5/6STE1LF	48.4	44	40.4
	27	HFW27R-5/6STE1LF	48.4	44	40.4
*	28	HFW28R-5/6STE1LF	48.4	44	40.4
*	29	HFW29R-5/6STE1LF	48.4	44	40.4
	30	HFW30R-5/6STE1LF	60.4	56	52.4

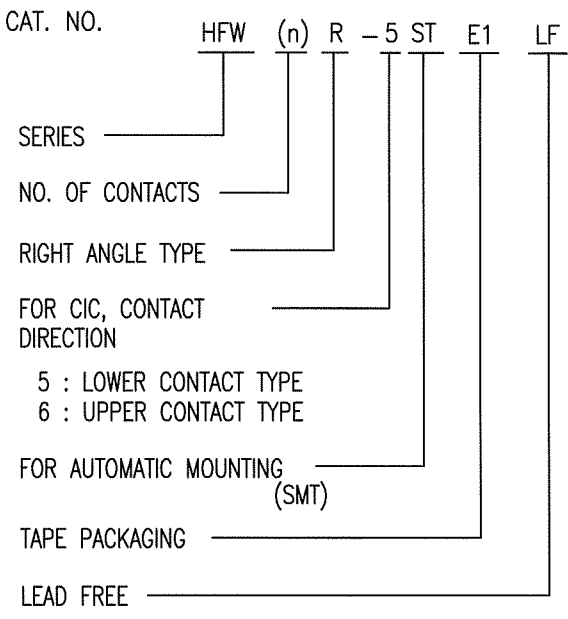

- NOTES
1. THIS PRODUCT IS THE CONNECTOR DESIGNED TO TERMINATE CIC AND COPES WITH AUTOMATIC MOUNTING (SMT).
 2. THIS CATALOG NO. INDICATES PLASTIC TAPE PACKAGED CONNECTOR.
 3. SEE PART DRAWINGS FOR DIMENSIONS E~G.
 4. PLEASE CONSULT US IN CASE OF USING PARTS WITH * MARK.

mat'l. code		surface ⁵⁸ / tolerance		projection		product family		CODE	
		ISO 1302 ✓ / ISO 406 / ISO 1101				58NF		JP	
ltr		ecn no		dr		date		title	
A		J07-0397		H.T		7/27/07		CAT. NO. TABLE FOR PLASTIC TAPE PACKAGED 1mm SPACING SMT CONN. (Cat.No. HFW__R-5/6STE1LF)	
				angles		linear		mm	
								scale X	
		dr		7/27/07		FCJ		dwg no	
		enr		7/27/07				sheet 1 of 1	
		chr		7/29/07				JSA 97342	
		appd		7/20/07				size	
								A4	
sheet index		revision		A				type	
sheet		1						Product Customer Drawing	
								Rev	
								A	



FCIconnect.com

Copyright FCI.

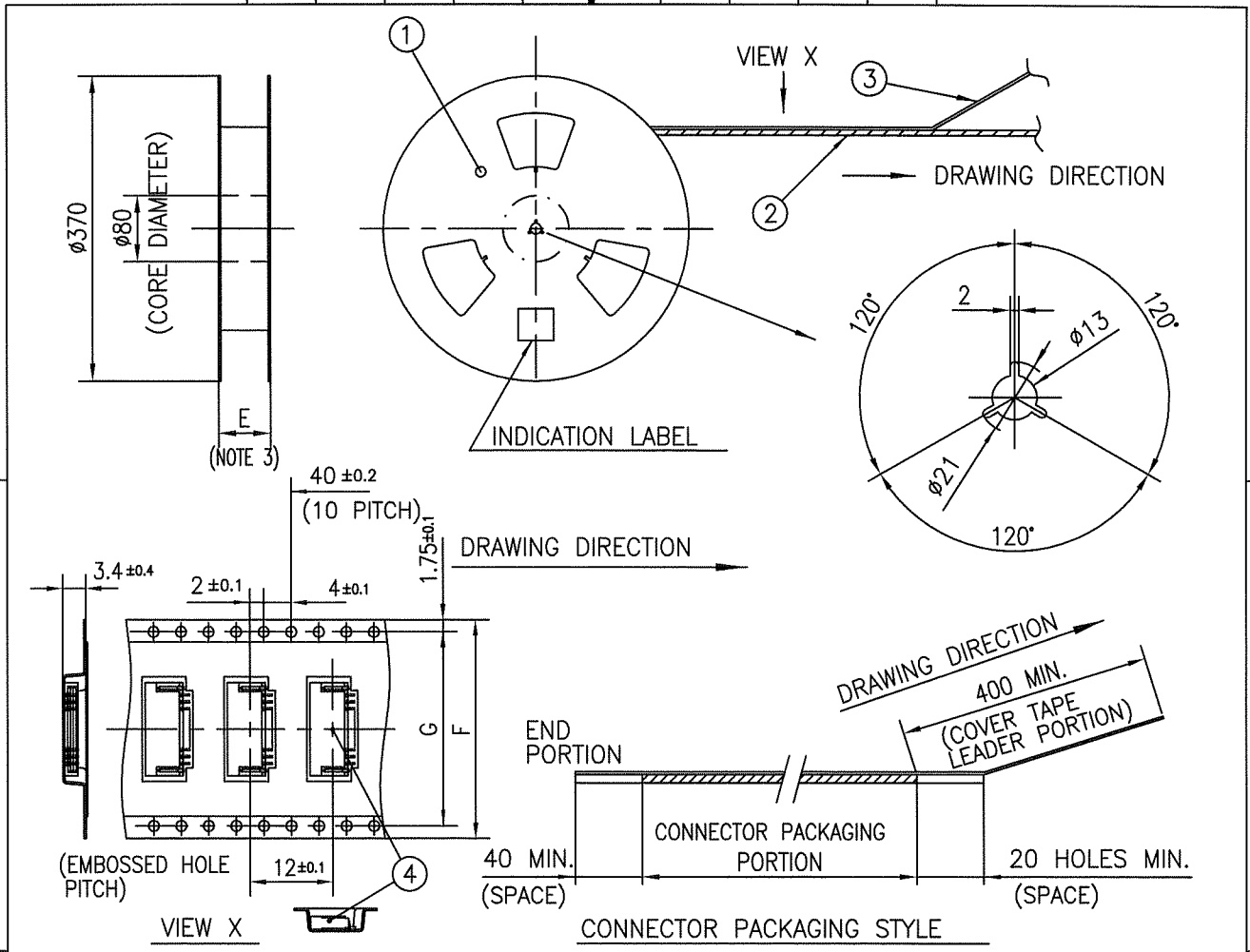

PT. NO.	PARTS NAME	CAT. NO.	MATERIAL	Q'TY	NOTE
1	REEL	—	CARDBOARD	1	COLOR:WHITE
2	PLASTIC (EMBOSSSED) TAPE	—	PET	—	COLOR:TRANSPARENCY
3	COVER	—	POLYESTER	—	COLOR:TRANSPARENCY
4	CONNECTOR	HFWR__R-5ST__LF	SEE ATTACHED DWG.	2000	LOWER CONTACT TYPE

NOTES

1. THIS IS PLASTIC TAPE PACKAGED CONNECTOR DESIGNED TO TERMINATE CIC AND COPES WITH AUTOMATIC MOUNTING (SMT).
2. SEE JIS C 0806 (PACKING OF ELECTRONIC COMPONENTS ON CONTINUOUS TAPES (SURFACE MOUNTING DEVICES)) FOR SHAPE AND DIMENSIONS OF PLASTIC (EMBOSSSED) TAPE AND REEL.
3. E DIMENSION IS PORTION OF THE CORE.

mat'l. code		surface 58 / tolerance ISO 1302 ✓ / ISO 406 / ISO 1101		projection		product family 58NF		CODE JP	
ltr	ecn no	dr	date	tolerances unless otherwise specified		title		dwg no	
A	J07-0397	H.T	7/27/07	angles	linear	1mm SPACING SMT CONNECTOR (Cat.No. HFWR__R-5STE1LF)		sheet 1 of 1 size	
				±5'		mm		JSA 97343	
						scale X		A4	
		dr	7/27/07	FCI		type Product Customer Drawing			
		enr	7/27/07						
		chr	7/27/07						
		appd	7/27/07						
sheet index	revision	A						Rev A	
	sheet	1							

SC-HFWR05 JSA97342 form: A4

FCI FCIconnect.com Copyright FCI.

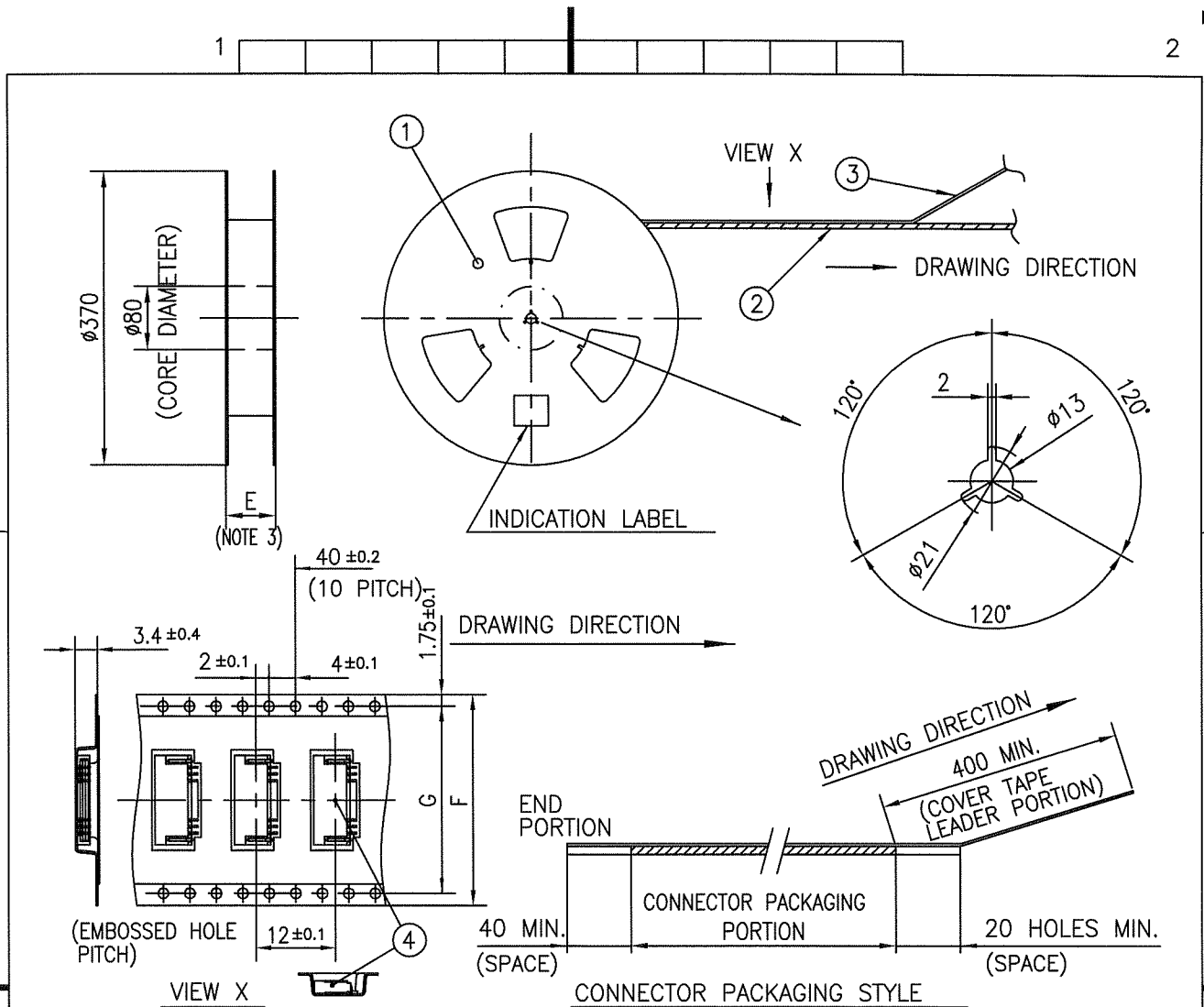

PT. NO.	PARTS NAME	CAT. NO.	MATERIAL	Q'TY	NOTE
1	REEL	_____	CARDBOARD	1	COLOR:WHITE
2	PLASTIC (EMBOSSED) TAPE	_____	PET	_____	COLOR:TRANSPARENCY
3	COVER	_____	POLYESTER	_____	COLOR:TRANSPARENCY
4	CONNECTOR	HFWR__R-6ST__LF	SEE ATTACHED DWG.	2000	UPPER CONTACT TYPE

NOTES

1. THIS IS PLASTIC TAPE PACKAGED CONNECTOR DESIGNED TO TERMINATE CIC AND COPES WITH AUTOMATIC MOUNTING (SMT).
2. SEE JIS C 0806 (PACKING OF ELECTRONIC COMPONENTS ON CONTINUOUS TAPES (SURFACE MOUNTING DEVICES)) FOR SHAPE AND DIMENSIONS OF PLASTIC (EMBOSSED) TAPE AND REEL.
3. E DIMENSION IS PORTION OF THE CORE.

mat'l. code		surface 58 / ISO 1302		tolerance ISO 406 / ISO 1101		projection		product family 58NF		CODE JP	
ltr ecn no dr date		A J07-0397 H.T 7/27/07		tolerances unless otherwise specified		mm		title		1mm SPACING SMT CONNECTOR (Cat.No. HFWR__R-6STE1LF)	
		angles ±5'		linear ±5		scale X		dwg no		sheet 1 of 1 size A4	
		dr engr chr appd		7/27/07 7/27/07 7/27/07 7/27/07		FCI		JSA 97344		type Product Customer Drawing	
sheet index		revision A sheet 1								Rev A	

SC-HFWR05 JSA97342 form: A4

RECOMMENDED CABLE (CIC)

n : NO. OF CONDUCTORS

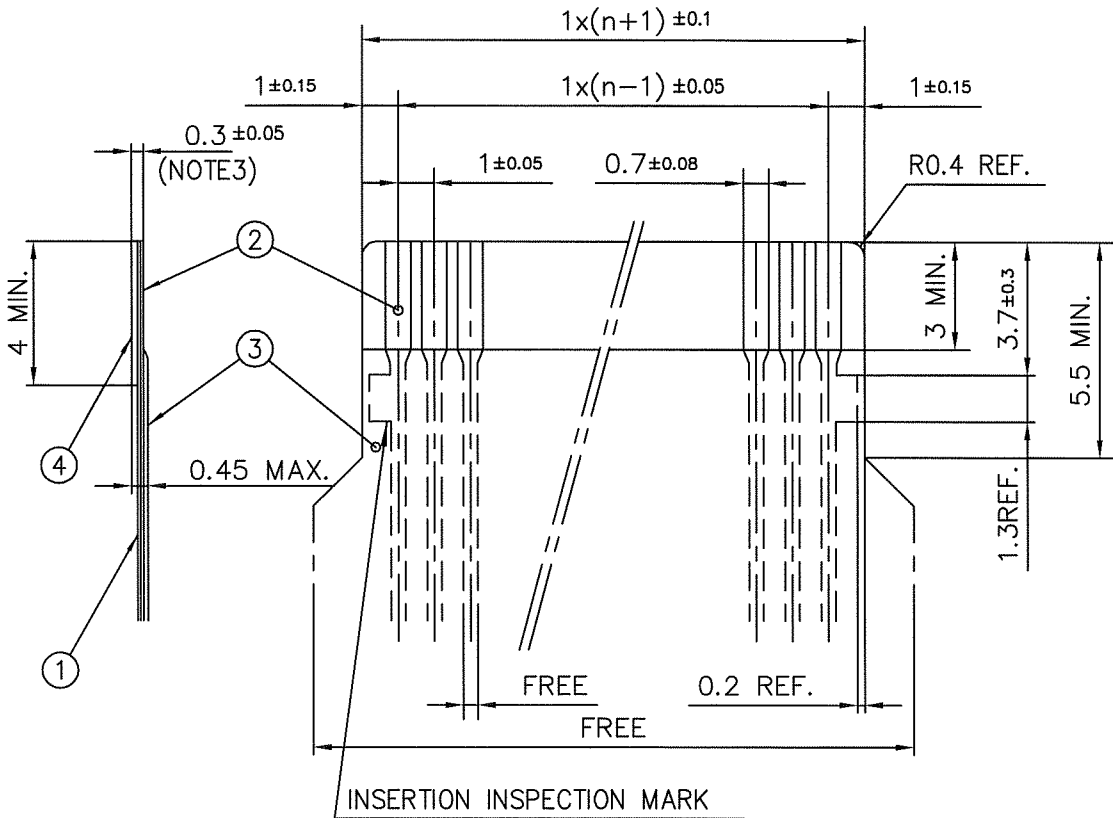

PT. NO.	DESCRIPTION	MATERIAL	THICKNESS (μm)	
1	BASE FILM	POLYIMIDE OR POLYESTER OR EQUIVALENT	75	25
2	CONDUCTOR	CARBON PASTE OVER SIVER PASTE	10MIN.	
3	OVERLAY	POLYIMIDE OR POLYESTER OR EQUIVALENT	—	
4	SUPPORTING TAPE	POLYESTER OR POLYIMIDE OR EQUIVALENT	188	250

NOTES

1. NO BURR AT EACH PORTION.
2. NO PEELING IN COMMON USE.
3. TOTAL THICKNESS LIMIT OF EACH MATERIAL (INCLUDING ADHESIVE AGENT) IS SPECIFIED.

mat'l. code				surface $\sqrt{58}$ / tolerance ISO 406 / ISO 1101		projection		product family 58NF		CODE JP	
ltr ecn no dr date				tolerances unless otherwise specified		mm		title			
A J07-0397 H.T 7/27/07				angles linear				RECOMMENDED CABLE (CIC) (Cat. No. HFW__R-5/6__)			
				dr				dwg no		sheet 1 of 1 size	
				enr				JSA 97345		A4	
				chr				type Product Customer Drawing			
				appd							
sheet index		revision sheet		A 1						Rev A	

Mouser Electronics

Authorized Distributor

Click to View Pricing, Inventory, Delivery & Lifecycle Information:

[FCI / Amphenol:](#)

[HFW4R-5STE1LF](#) [HFW6R-6STE1LF](#)