

REVISIONS					
P.	LTN	DESCRIPTION	DATE	OWN	APVD
CF	REV PER ECO-17-010490		19JUL2017	RGV	WTW
CG	REV PER ECO-17-014327		03OCT2017	JMS	WW
CH	REVISED PER ECO-18-002641		22FEB2018	JMS	WW

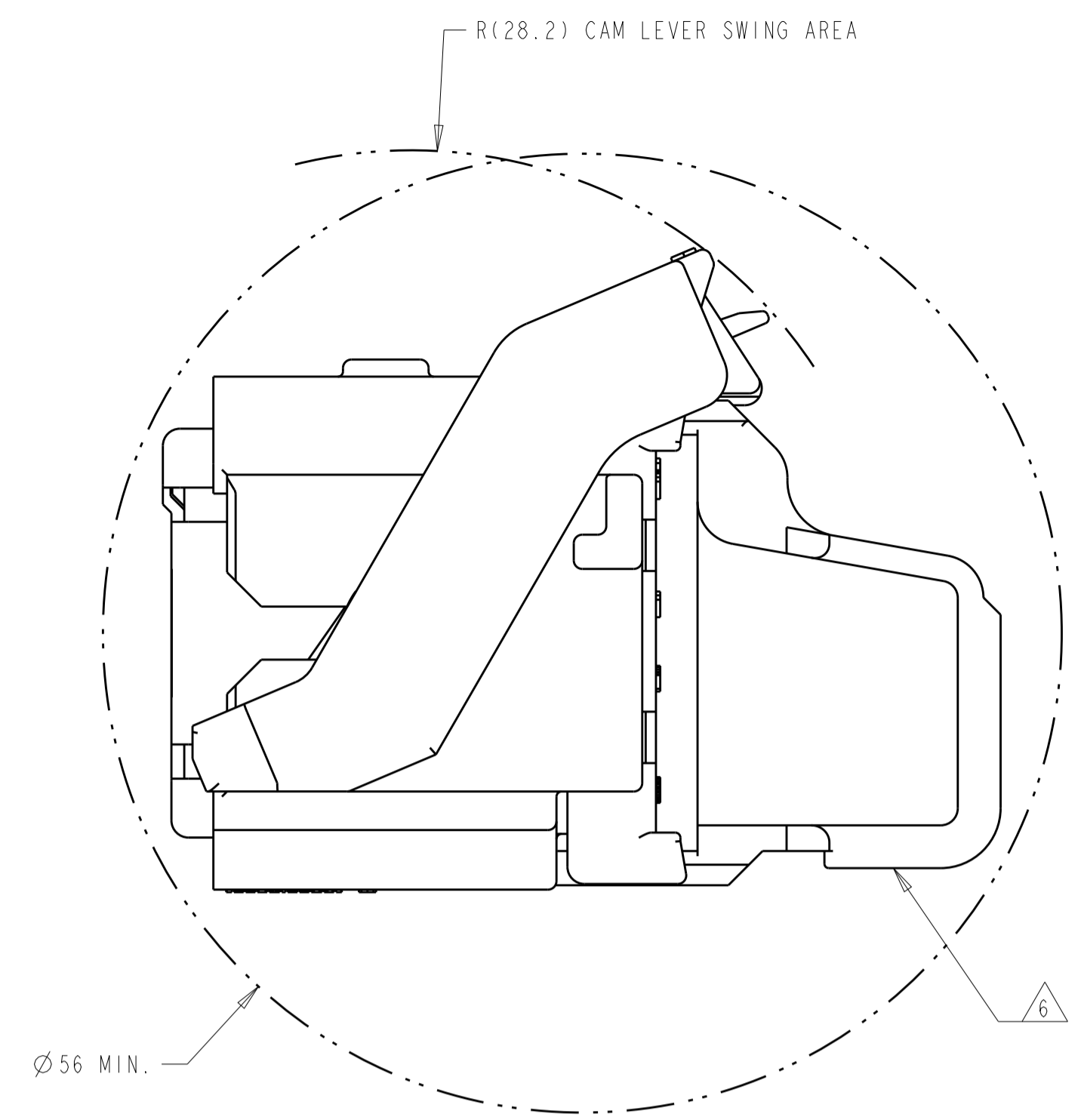

KEYING OPTIONS  
 SCALE 2:1

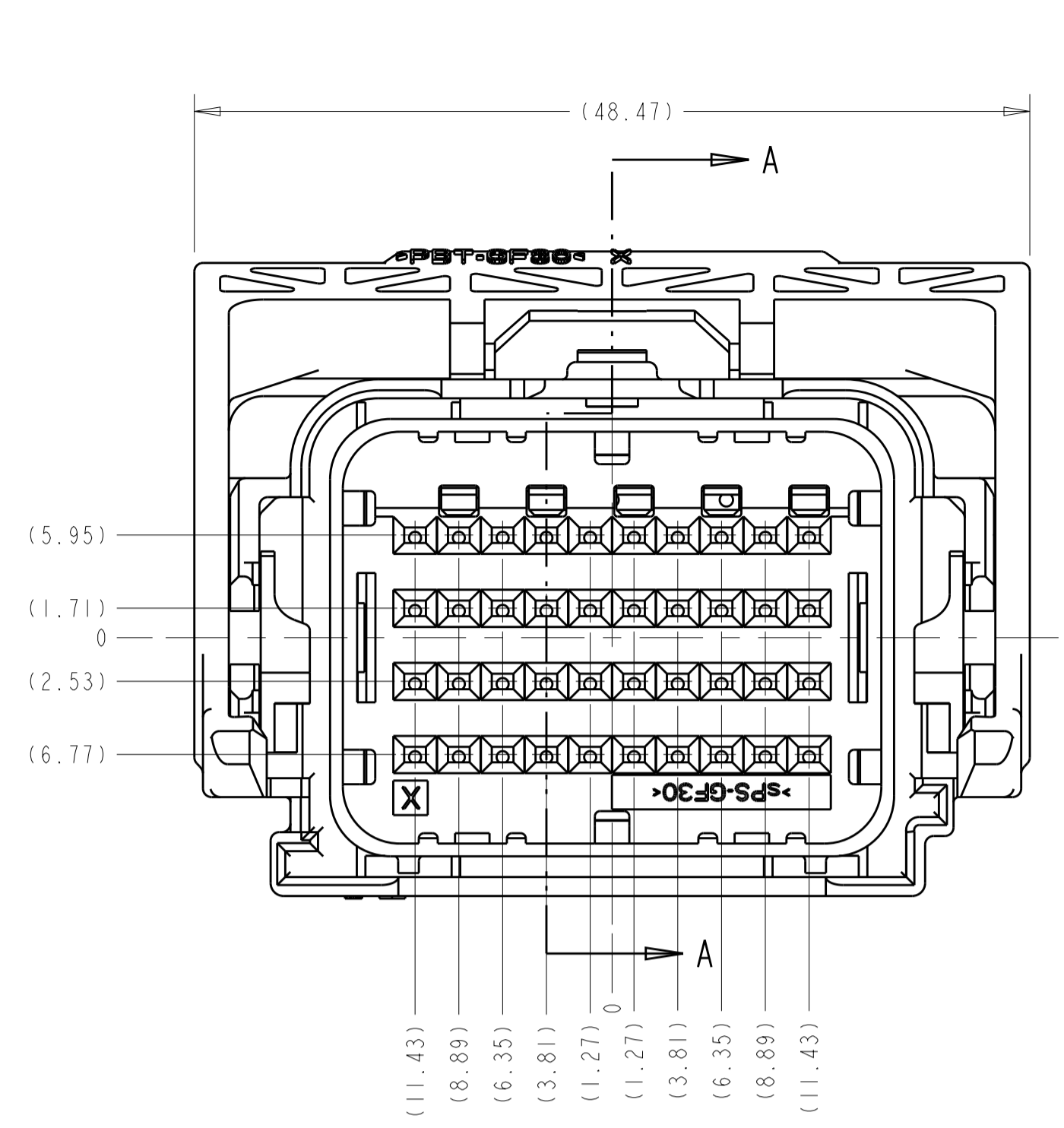
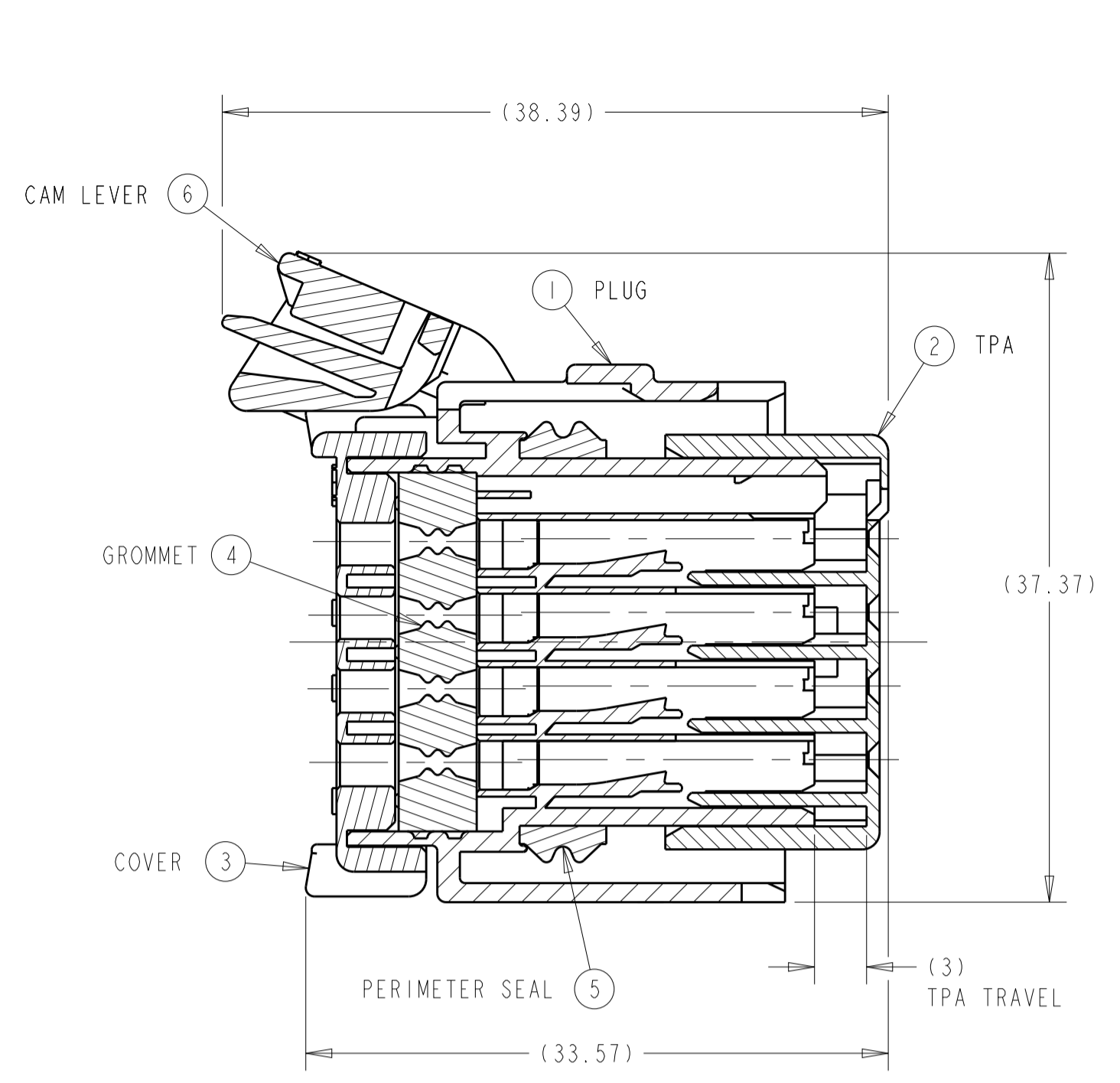
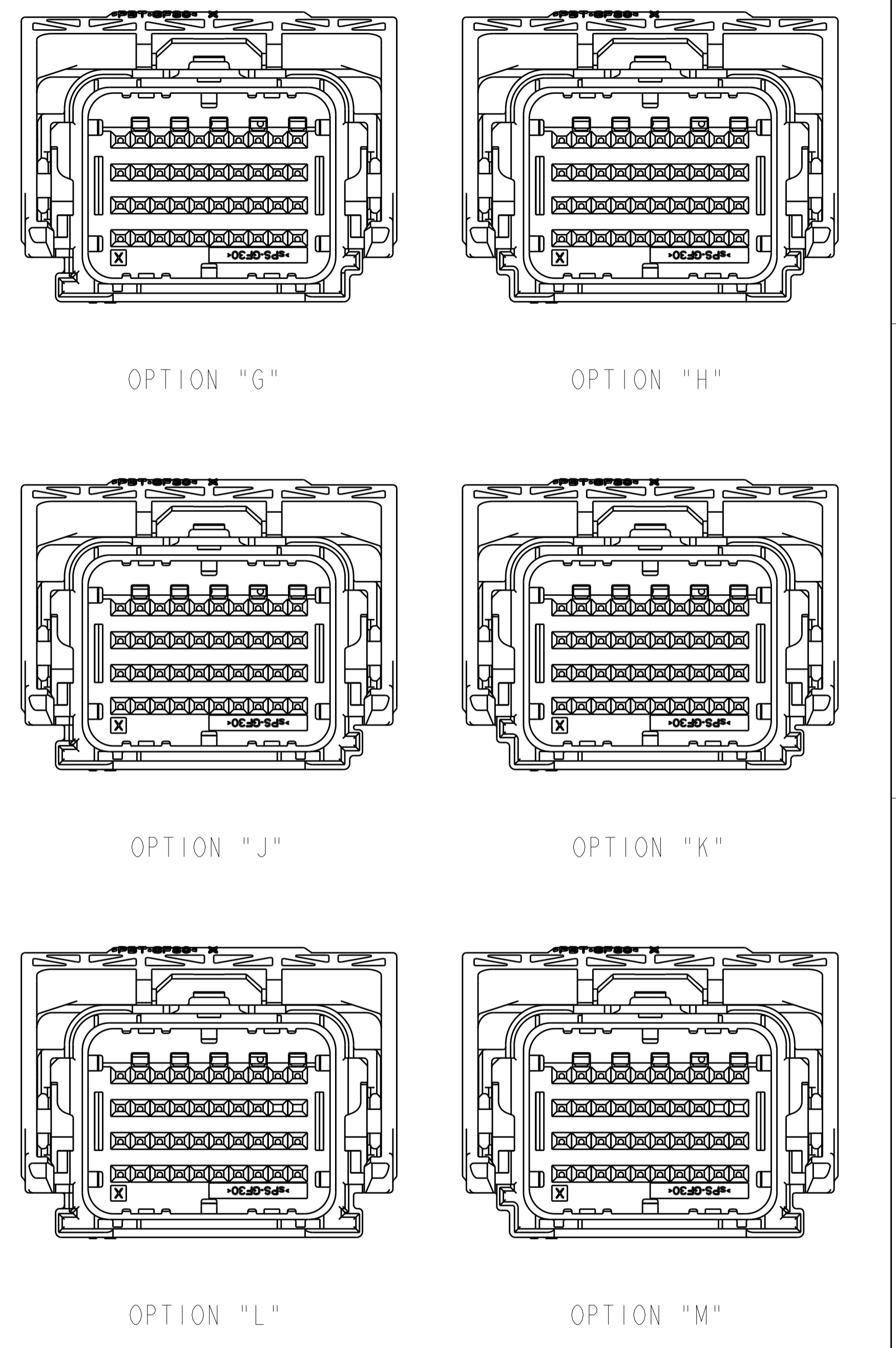

MINIMUM FEED THROUGH CONDITION  
 WITH 1mm CLEARANCE ALL AROUND  
 SHOWN WITH OPTION WIRESHIELD  
 TPA IS IN IT'S LOADED POSITION  
 CAM LEVER IS IN IT'S PRE-LOADED POSITION

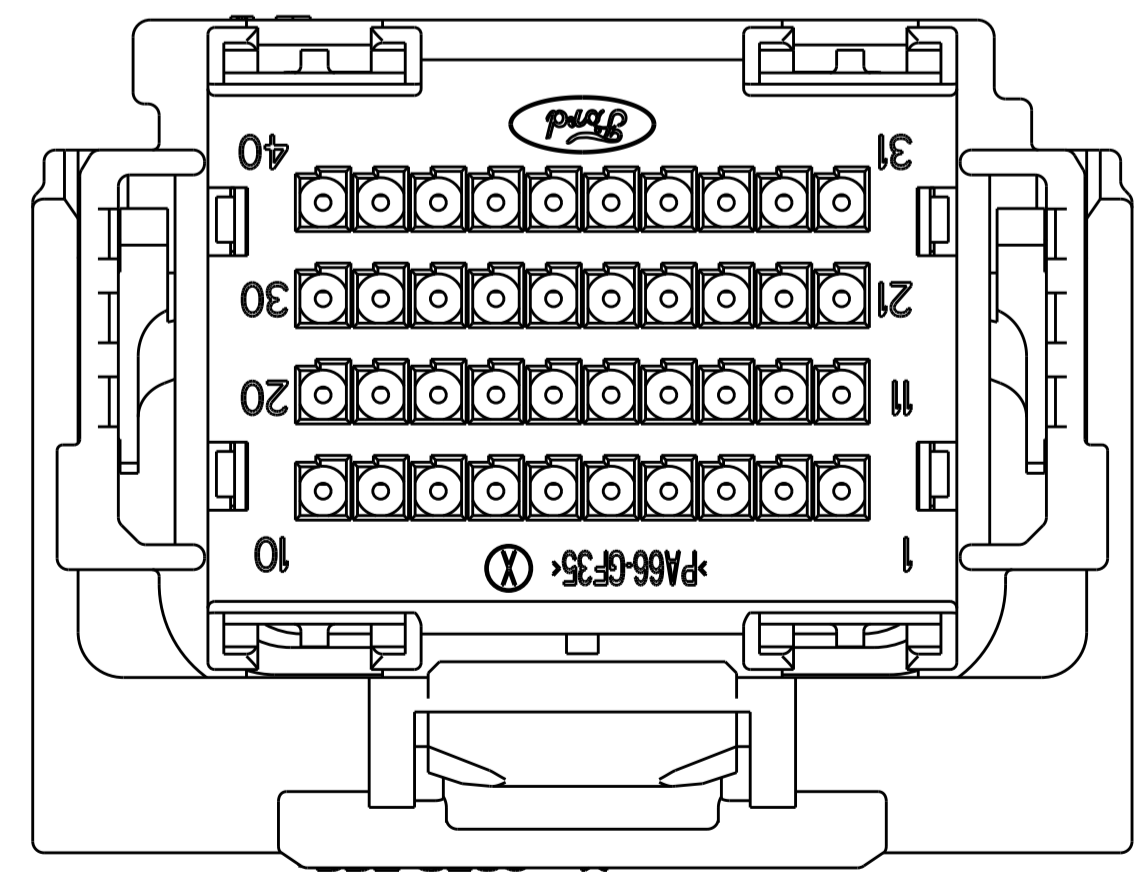
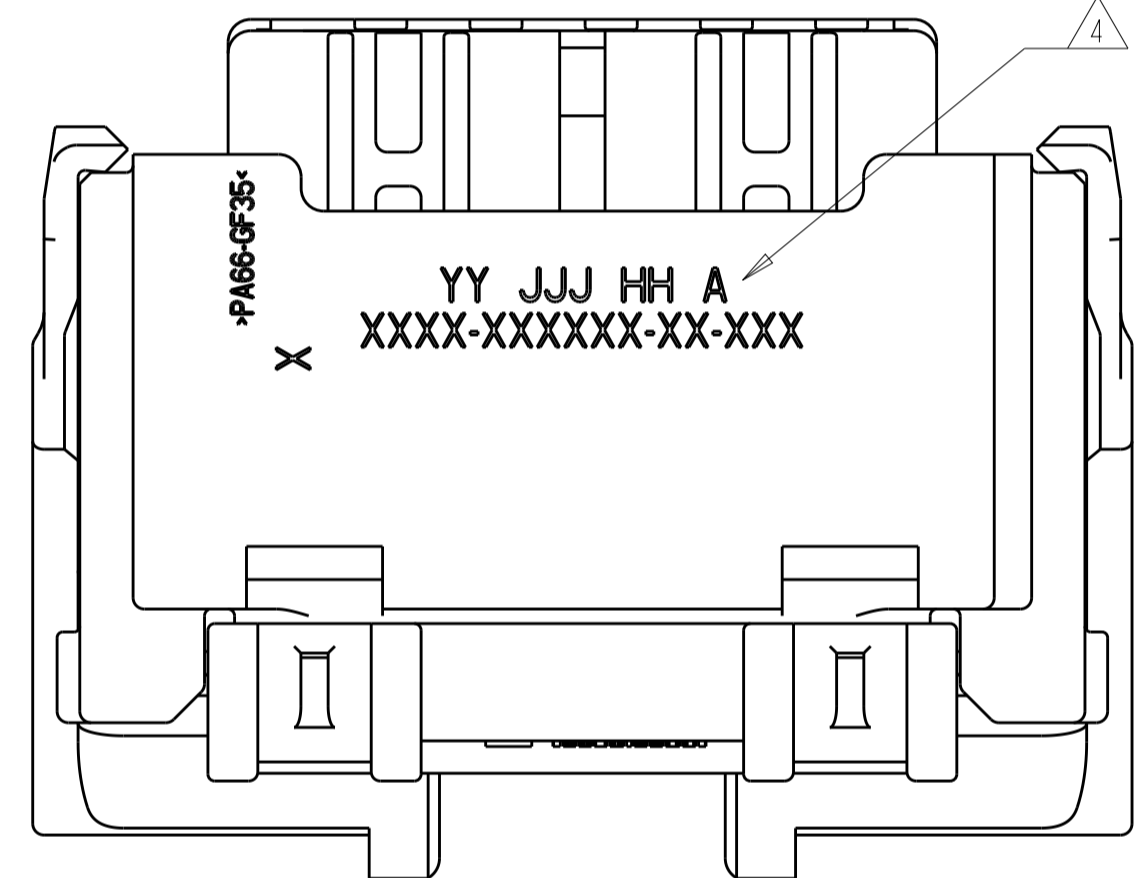
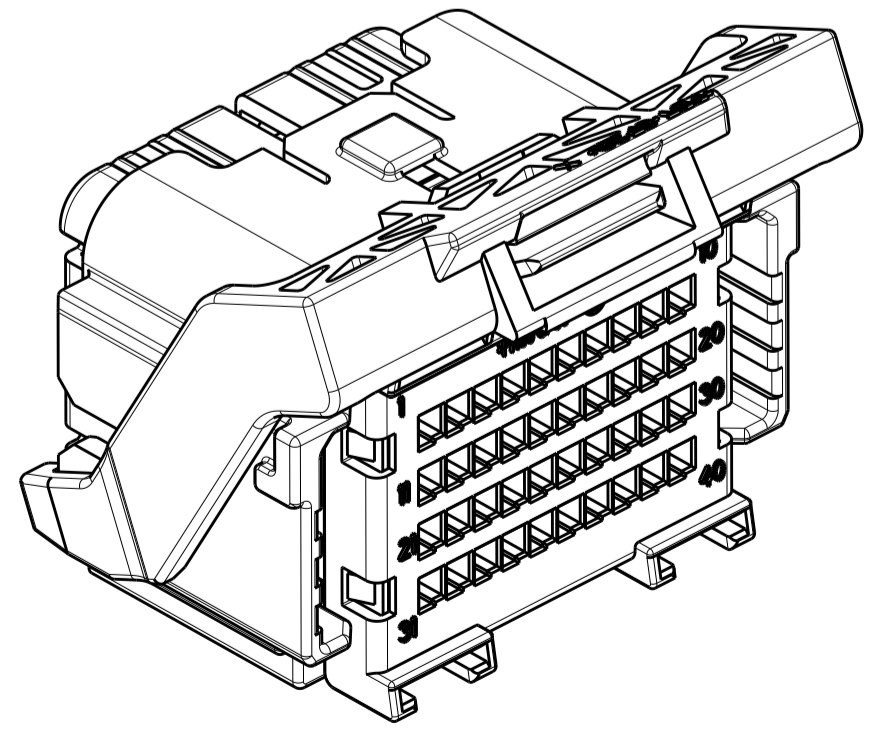
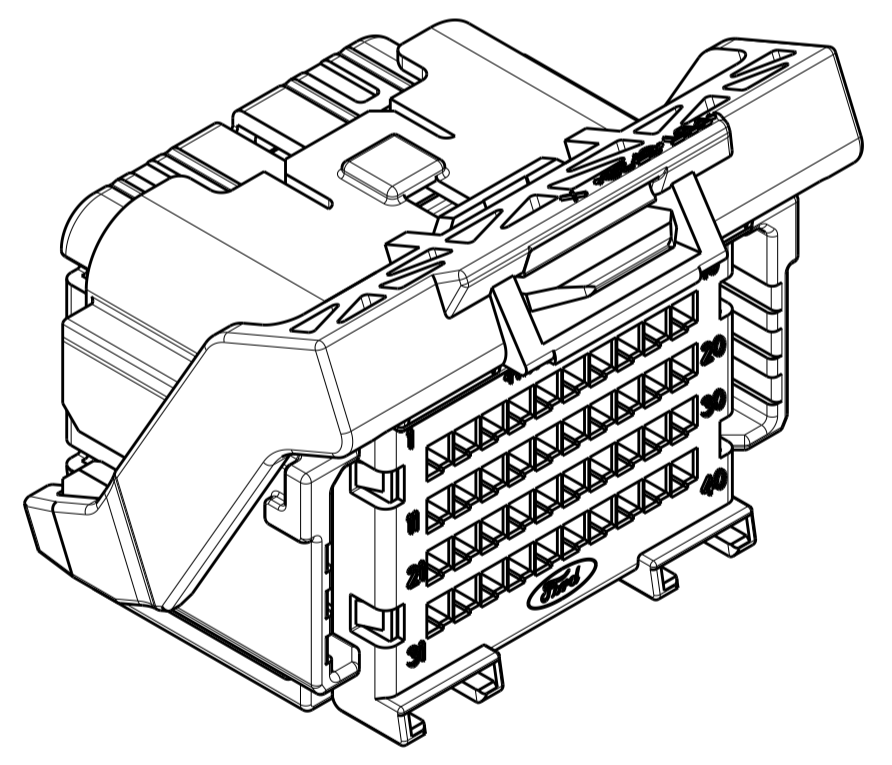

- APPLICABLE TERMINAL PART NUMBERS (SOLD SEPARATELY):  
 FOR TIN APPLICATIONS: 1393367 AND 1393366.  
 FOR GOLD APPLICATIONS: 1393365 AND 1393364.  
 FOR TERMINATION AND REELING OPTIONS  
 SEE DRAWINGS 1393367, 1393366, 1393365, AND 1393364.
- COMPATIBLE WIRE SIZES FOR MAT SEAL DESIGN 1.19 TO 2.06 O.D.  
 (22-18 AWG, 0.35-0.75 mm<sup>2</sup>)
- TPA AND CAM LEVER ARE SHIPPED IN THEIR PRE-LOADED POSITION.  
 ALL ASSEMBLIES ARE TO BE TRAY PACKAGED.
- CUSTOMER PART NUMBER AND TRACEABILITY CODE (YY = TWO DIGIT YEAR,  
 JJJ = JULIAN DAY, HH = TWO DIGIT MILITARY HOUR, A = ASSEMBLY PROCESS  
 USED) ARE PRINTED IN THIS LOCATION.
- PART ASSEMBLY WEIGHT WITHOUT TERMINALS AND WITH STANDARD PIN-OUT  
 CONFIGURATION IS 24.71 GRAMS.
- OPTIONAL WIRESHIELD P/N 8-1419157-8 (SOLD SEPARATELY). PLEASE CONTACT  
 YOUR TE SALES REPRESENTATIVE FOR AVAILABILITY AND PRICING.

KEYING OPTION "G" SHOWN  
 SEE SHEET 2 FOR BILL OF  
 MATERIAL AND PIN-OUT CHARTS

THIS DRAWING IS A CONTROLLED DOCUMENT.		OWN: M. FORLSKA 19APR2002	
DIMENSIONS: mm		CHK: M. FORLSKA 19APR2002	
TOLERANCES UNLESS OTHERWISE SPECIFIED:		APVD: A. VALASEK 19APR2002	NAME: 40 WAY ARM, PLUG ASSEMBLY WITHOUT SHORTING BARS, CUSTOMER SPEC.
0 PLC ± 1 PLC ±0.3 2 PLC ±0.10 3 PLC ± 4 PLC ± ANGLES ±°		PRODUCT SPEC	
MATERIAL: SEE CHART ON SHEET 2		FINISH: -	APPLICATION SPEC
WEIGHT: SEE NOTE 5		SIZE: A1	RESTRICTED TO
CUSTOMER DRAWING		CAGE CODE: 00779	SCALE: 3:1
		DRAWING NO: 8-1419157-7	SHEET 1 OF 5
		REV: CH	

REVISIONS				
P.	LTN	DESCRIPTION	DATE	OWN APVD
-	-	SEE SHEET 1	-	-

ASSEMBLY PART NUMBERS										ITEM	DESCRIPTION	MATERIAL	FINISH/COLOR	
											6	CAM LEVER	PBT 30% GF	GRAY
											6	CAM LEVER WITH MODIFIED TAB	PA66 35% GF	GRAY
											6	CAM LEVER WITH MODIFIED TAB	PBT 30% GF	GRAY
											5	PERIMETER SEAL	SILICONE	GREEN
											4	GROMMET	SILICONE	BROWN
											3	COVER	PA66 35% GF	BLACK
											2	TPA FOR NON-SHORTING BAR APPLICATIONS	sPS 30% GF	NATURAL
											2	TPA FOR NON-SHORTING BAR APPLICATIONS	sPS 30% GF	RED
											1	PLUG WITH KEYING OPTION "K" AND 5 SHORTING BAR POSITIONS CONFIGURATION	PA66 35% GF	BLACK
											1	PLUG WITH KEYING OPTION "L" AND 5 SHORTING BAR POSITIONS CONFIGURATION	PA66 35% GF	BLACK
											1	PLUG WITH KEYING OPTION "J" AND 5 SHORTING BAR POSITIONS CONFIGURATION	PA66 35% GF	BLACK
											1	PLUG WITH KEYING OPTION "H" AND 5 SHORTING BAR POSITIONS CONFIGURATION	PA66 35% GF	BLACK
											1	PLUG WITH KEYING OPTION "G" AND 5 SHORTING BAR POSITIONS CONFIGURATION	PA66 35% GF	BLACK

ASSEMBLY PART NUMBERS										ITEM	DESCRIPTION	MATERIAL	FINISH/COLOR	
											6	CAM LEVER	PBT 30% GF	GRAY
											6	CAM LEVER WITH MODIFIED TAB	PA66 35% GF	GRAY
											6	CAM LEVER WITH MODIFIED TAB	PBT 30% GF	GRAY
											5	PERIMETER SEAL	SILICONE	GREEN
											4	GROMMET	SILICONE	BROWN
											3	COVER	PA66 35% GF	BLACK
											2	TPA FOR NON-SHORTING BAR APPLICATIONS	sPS 30% GF	NATURAL
											2	TPA FOR NON-SHORTING BAR APPLICATIONS	sPS 30% GF	RED
											1	PLUG WITH KEYING OPTION "K" AND 5 SHORTING BAR POSITIONS CONFIGURATION	PA66 35% GF	BLACK
											1	PLUG WITH KEYING OPTION "L" AND 5 SHORTING BAR POSITIONS CONFIGURATION	PA66 35% GF	BLACK
											1	PLUG WITH KEYING OPTION "J" AND 5 SHORTING BAR POSITIONS CONFIGURATION	PA66 35% GF	BLACK
											1	PLUG WITH KEYING OPTION "H" AND 5 SHORTING BAR POSITIONS CONFIGURATION	PA66 35% GF	BLACK
											1	PLUG WITH KEYING OPTION "G" AND 5 SHORTING BAR POSITIONS CONFIGURATION	PA66 35% GF	BLACK

ASSEMBLY PART NUMBERS										ITEM	DESCRIPTION	MATERIAL	FINISH/COLOR	
											6	CAM LEVER	PBT 30% GF	GRAY
											6	CAM LEVER WITH MODIFIED TAB	PA66 35% GF	GRAY
											6	CAM LEVER WITH MODIFIED TAB	PBT 30% GF	GRAY
											5	PERIMETER SEAL	SILICONE	GREEN
											4	GROMMET	SILICONE	BROWN
											3	COVER	PA66 35% GF	BLACK
											2	TPA FOR NON-SHORTING BAR APPLICATIONS	sPS 30% GF	NATURAL
											2	TPA FOR NON-SHORTING BAR APPLICATIONS	sPS 30% GF	RED
											1	PLUG WITH KEYING OPTION "K" AND 5 SHORTING BAR POSITIONS CONFIGURATION	PA66 35% GF	BLACK
											1	PLUG WITH KEYING OPTION "L" AND 5 SHORTING BAR POSITIONS CONFIGURATION	PA66 35% GF	BLACK
											1	PLUG WITH KEYING OPTION "J" AND 5 SHORTING BAR POSITIONS CONFIGURATION	PA66 35% GF	BLACK
											1	PLUG WITH KEYING OPTION "H" AND 5 SHORTING BAR POSITIONS CONFIGURATION	PA66 35% GF	BLACK
											1	PLUG WITH KEYING OPTION "G" AND 5 SHORTING BAR POSITIONS CONFIGURATION	PA66 35% GF	BLACK

THIS DRAWING IS A CONTROLLED DOCUMENT. DIMENSIONS: mm 		TOLERANCES UNLESS OTHERWISE SPECIFIED: 0 PLC ±0.3 1 PLC ±0.10 2 PLC ±0.10 3 PLC ±0.10 4 PLC ±0.10 ANGLES ±0.5°		DWG: M. FORISKA 19APR2002 CHK: M. FORISKA 19APR2002 APVD: A. VALASEK 19APR2002 PRODUCT SPEC: - APPLICATION SPEC: - WEIGHT: SEE NOTE 5 CUSTOMER DRAWING		NAME: 40 WAY ARM, PLUG ASSEMBLY WITHOUT SHORTING BARS, CUSTOMER SPEC. SIZE: A1 CAGE CODE: 00779 DRAWING NO: 8-1419157-7 SCALE: 3:1 SHEET: 2 OF 5 REV: CH	
---	--	--	--	--	--	--	--



PIN-OUT CHART table with columns for terminal positions (1-40) and rows for various part numbers (e.g., 4-1438099-4, 4-1438099-3, 4-1438099-2, etc.) and their corresponding keying options (KEY "J", KEY "H", KEY "L", KEY "G").

PIN-OUT CHART table for part number 2098034-1, showing terminal positions (1-40) and keying options (KEY "H", KEY "L", KEY "J").

TERMINAL HOLE POSITION. CAVITIES WITH A NUMERIC SYMBOL INDICATE CLOSED TERMINAL HOLE POSITIONS. BLANK CAVITIES INDICATE OPEN TERMINAL HOLE POSITIONS.

Technical drawing footer containing dimensions, tolerances, material, and customer drawing information. Includes a drawing of a terminal hole and the STC logo.



# Mouser Electronics

Authorized Distributor

Click to View Pricing, Inventory, Delivery & Lifecycle Information:

[TE Connectivity:](#)

[1438620-1](#)