

THIS DRAWING IS UNPUBLISHED. RELEASED FOR PUBLICATION .19  
 © COPYRIGHT 19 BY AMP INCORPORATED. ALL RIGHTS RESERVED.

| LOC | DIST | REVISIONS |     |                       |         |     |      |
|-----|------|-----------|-----|-----------------------|---------|-----|------|
|     |      | P         | LTR | DESCRIPTION           | DATE    | DWN | APVD |
| DY  | -    | L         |     | REVISED ECR-10-012020 | 23JUL10 | LYM | LSF  |

NOTES:  
 1 MATERIAL:  
 HOUSING: GLASS FILLED HIGH TEMP NYLON, NATURAL COLOR (BEIGE)  
 CONTACT: PHOSPHOR BRONZE  
 2 FINISH: MATTE TIN OVER NICKEL UNDERPLATE  
 3. PACKAGING: TAPE & REEL (PACKAGING SPEC: 107-51189)

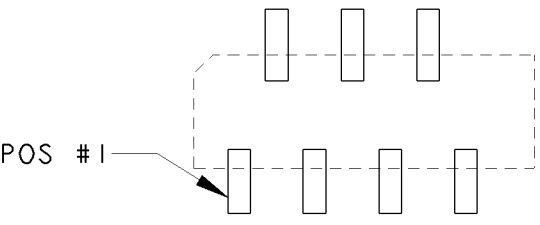
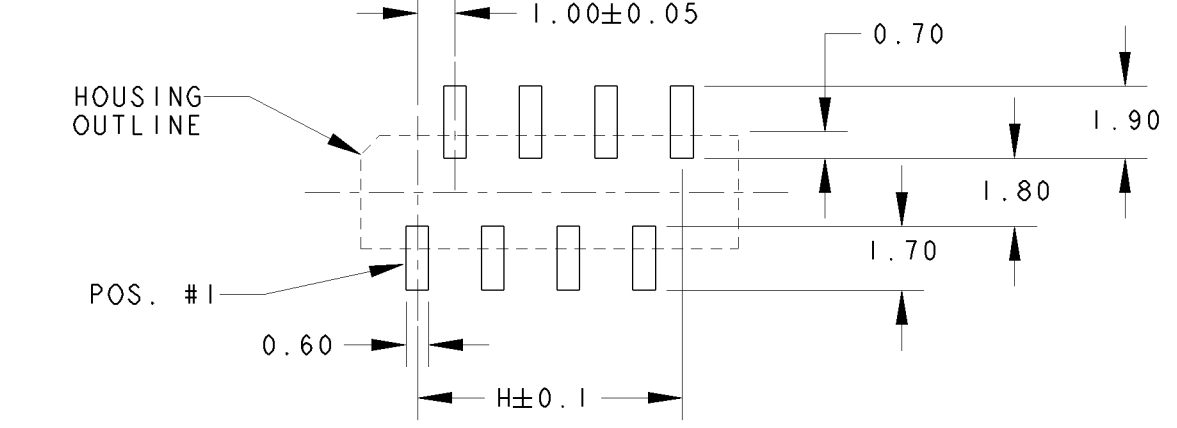
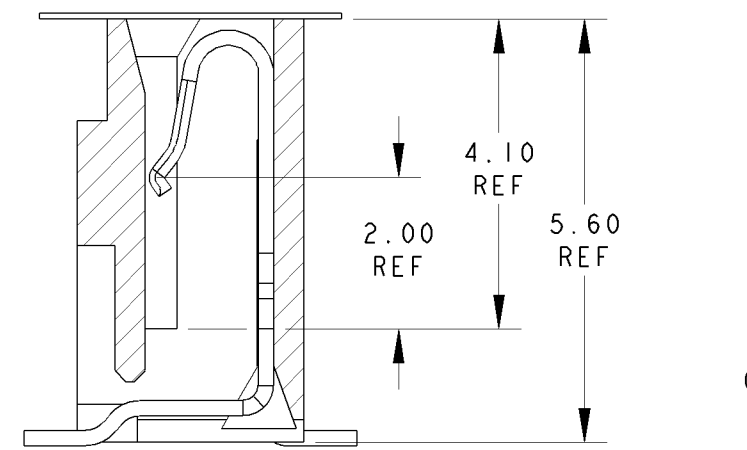
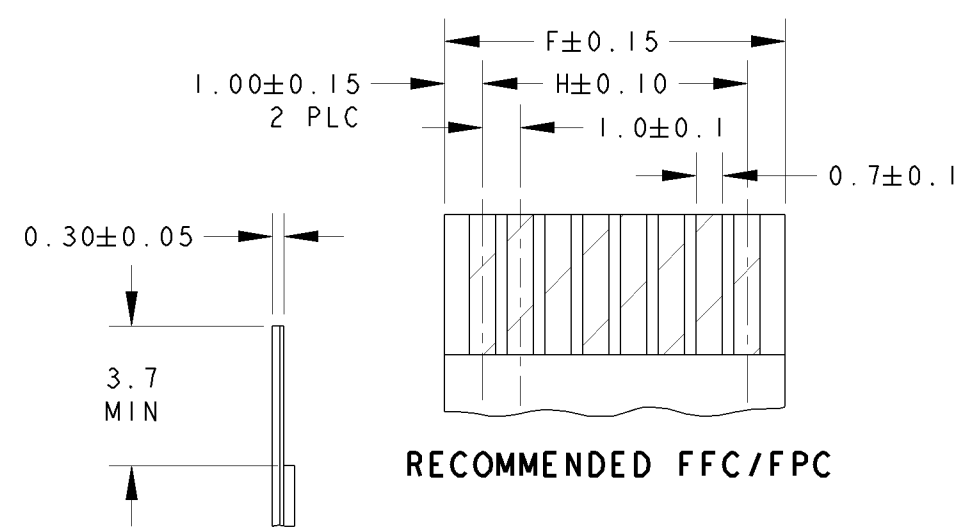

|       |       |       |       |      |           |    |    |
|-------|-------|-------|-------|------|-----------|----|----|
| 29.00 | 32.00 | 31.00 | 31.00 | 10.0 | 30        | 3- | -0 |
| 28.00 | 31.00 | 30.00 | 30.00 |      | 29        | 2- | -9 |
| 27.00 | 30.00 | 29.00 | 29.00 |      | 28        | 2- | -8 |
| 26.00 | 29.00 | 28.00 | 28.00 |      | 27        | 2- | -7 |
| 25.00 | 28.00 | 27.00 | 27.00 |      | 26        | 2- | -6 |
| 24.00 | 27.00 | 26.00 | 26.00 |      | 25        | 2- | -5 |
| 23.00 | 26.00 | 25.00 | 25.00 |      | 24        | 2- | -4 |
| 22.00 | 25.00 | 24.00 | 24.00 |      | 23        | 2- | -3 |
| 21.00 | 24.00 | 23.00 | 23.00 |      | 22        | 2- | -2 |
| 20.00 | 23.00 | 22.00 | 22.00 |      | 21        | 2- | -1 |
| 19.00 | 22.00 | 21.00 | 21.00 | 20   | 2-        | -0 |    |
| 18.00 | 21.00 | 20.00 | 20.00 | 19   | 1-        | -9 |    |
| 17.00 | 20.00 | 19.00 | 19.00 | 18   | 1-        | -8 |    |
| 16.00 | 19.00 | 18.00 | 18.00 | 17   | 1-        | -7 |    |
| 15.00 | 18.00 | 17.00 | 17.00 | 16   | 1-        | -6 |    |
| 14.00 | 17.00 | 16.00 | 16.00 | 15   | 1-        | -5 |    |
| 13.00 | 16.00 | 15.00 | 15.00 | 14   | 1-        | -4 |    |
| 12.00 | 15.00 | 14.00 | 14.00 | 13   | 1-        | -3 |    |
| 11.00 | 14.00 | 13.00 | 13.00 | 12   | 1-        | -2 |    |
| 10.00 | 13.00 | 12.00 | 12.00 | 11   | 1-        | -1 |    |
| 9.00  | 12.00 | 11.00 | 11.00 | 10   | 1-        | -0 |    |
| 8.00  | 11.00 | 10.00 | 10.00 | 8.0  | 9         | -9 |    |
| 7.00  | 10.00 | 9.00  | 9.00  |      | 8         | -8 |    |
| 6.00  | 9.00  | 8.00  | 8.00  | 5.0  | 7         | -7 |    |
| 5.00  | 8.00  | 7.00  | 7.00  |      | 6         | -6 |    |
| 4.00  | 7.00  | 6.00  | 6.00  |      | 5         | -5 |    |
| 3.00  | 6.00  | 5.00  | 5.00  | 4    | 1735042-4 |    |    |

RECOMMENDED PCB LAYOUT (NON-ACCUMULATIVE TOLERANCE) (FOR EVEN POSITION CONNECTORS)

RECOMMENDED PCB LAYOUT (FOR ODD POSITION CONNECTORS)

|   |  |                        |   |                 |
|---|--|------------------------|---|-----------------|
| THIS DRAWING IS A CONTROLLED DOCUMENT FOR AMP INCORPORATED. IT IS SUBJECT TO CHANGE AND THE CONTROLLING ENGINEERING ORGANIZATION SHOULD BE CONTACTED FOR THE LATEST REVISION. |  | DWN WYLEE 25JUN04      | Tyco Electronics Corporation Singapore  |                 |
| DIMENSIONS: mm  |  | CHK LP TAN             | NAME ON TAPING (EMBOSS)                 |                 |
| TOLERANCES UNLESS OTHERWISE SPECIFIED:  |  | APVD SF LEONG          | ASSY, 1.00mm FFC CONN. WITH KAPTON TAPE |                 |
| 0 PLC ±0.3  |  | PRODUCT SPEC 108-51054 | SMT, V, (NON-ZIF)                       |                 |
| 1 PLC ±0.3  |  | APPLICATION SPEC -     | SIZE A3                                 | CAGE CODE 00779 |
| 2 PLC ±0.3  |  | WEIGHT -               | DRAWING NO C-1735042                    |                 |
| 3 PLC ±0.3  |  | CUSTOMER DRAWING       | SCALE 2:1                               | SHEET 1 OF 1    |
| 4 PLC ±0.3  |  |                        |   | REV L           |
| ANGLES ±3°  |  |                        |   |                 |
| FINISH 1  |  |                        |   |                 |
| FINISH 2  |  |                        |   |                 |

# Mouser Electronics

Authorized Distributor

Click to View Pricing, Inventory, Delivery & Lifecycle Information:

[TE Connectivity:](#)

[3-1735042-0](#)