

THIS DRAWING IS UNPUBLISHED.

RELEASED FOR PUBLICATION

---

ALL RIGHTS RESERVED.

© COPYRIGHT - By -

LOC E DIST B

REVISIONS

| P | LTR | DESCRIPTION               | DATE    | DWN | APVD |
|---|-----|---------------------------|---------|-----|------|
| P |     | REVISED PER ECO-11-005150 | 21MAR11 | RK  | HMR  |

TECHNICAL SPECIFICATION

|                     |  |
|---------------------|--|
| DISSIPATION AT 25°C | 16 WATTS MOUNTED ON STANDARD HEATSINK          |
| BS OHMIC RANGE      | R01 TO 10K                                     |
| STABILITY           | $\Delta R \leq 1\%$ PER 1000HRS                |
| ISOLATION VOLTAGE   | 1400V DC/AC PK                                 |
| MAX WORKING VOLTAGE | 265V DC/AC RMS                                 |
| TEMP COEFFICIENT    | <100R $\pm 50$ ppm/°C<br>>100R $\pm 30$ ppm/°C |
| CLIMATIC CATEGORY   | 55/200/56                                      |

FOR FURTHER INFORMATION SEE DATA SHEET FOR THS SERIES ALUMINIUM HOUSED RESISTORS

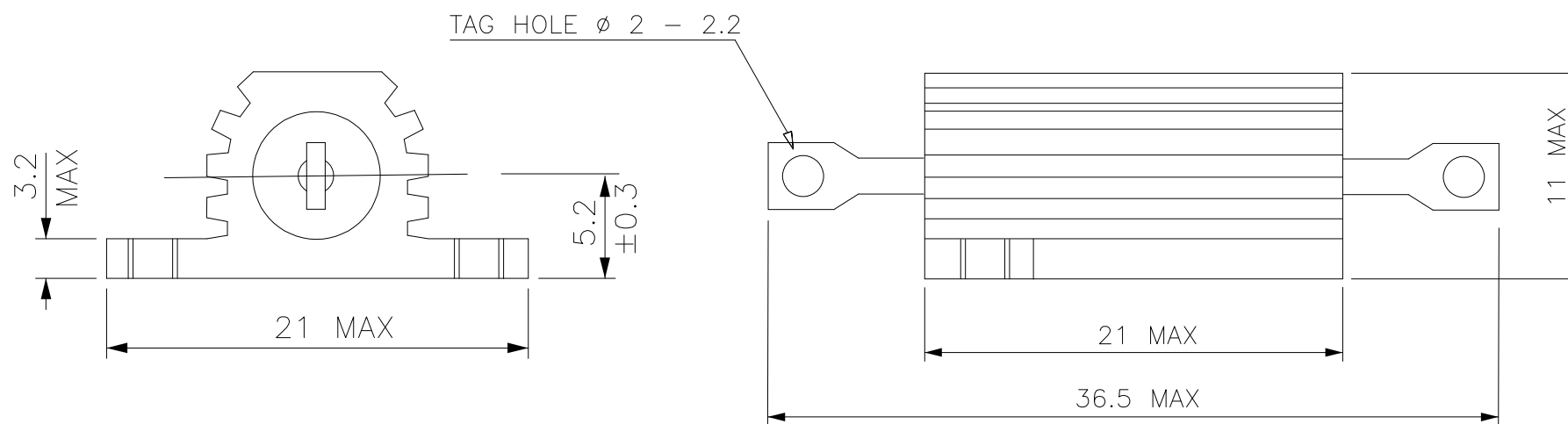
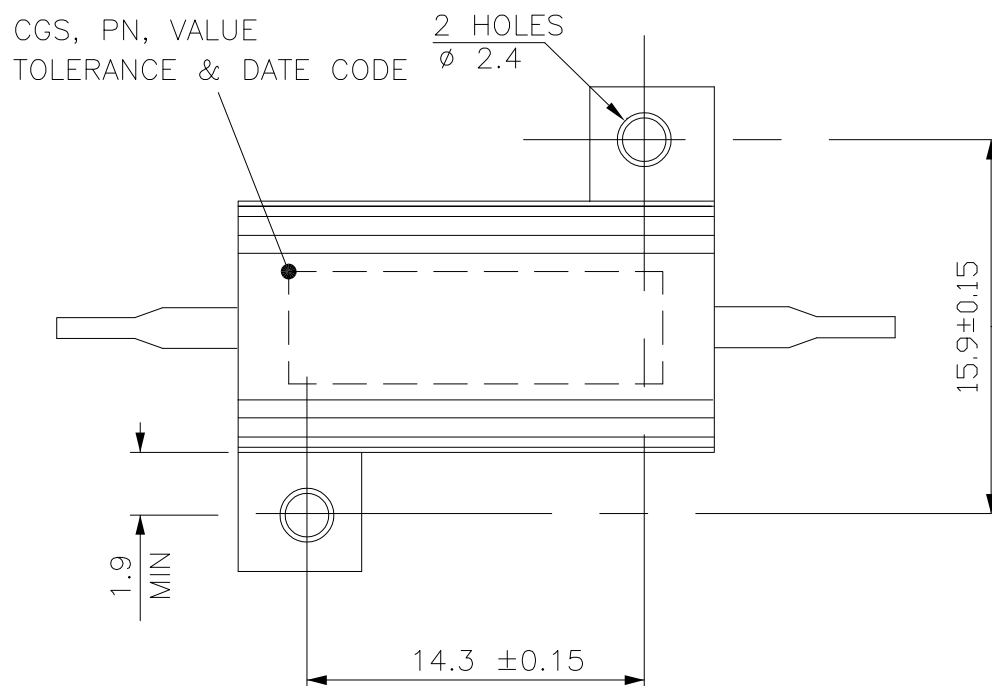

FOR A SPECIFIC PN A RESISTANCE VALUE AND TOLERANCE, PLEASE REFER TO DMF.

RoHS Compliant

|  |  |                           |   |                      |                 |
|--|--|---------------------------|---|----------------------|-----------------|
| THIS DRAWING IS A CONTROLLED DOCUMENT. |  | DWN R BLANCH 19SEPT06     |  TE Connectivity |                      |                 |
| DIMENSIONS: mm                         |  | CHK J CATCHPOLE 19SEPT06  |   |                      |                 |
| TOLERANCES UNLESS OTHERWISE SPECIFIED: |  | APVD J CATCHPOLE 19SEPT06 | PRODUCT SPEC  |                      |                 |
| 0 PLC $\pm 0.5$                        |  | APPLICATION SPEC          |   |                      |                 |
| 1 PLC $\pm 0.2$                        |  | WEIGHT -                  |   |                      |                 |
| 2 PLC $\pm 0.1$                        |  | SIZE A3                   | CAGE CODE 00779   | DRAWING NO C-1879074 | RESTRICTED TO - |
| 3 PLC $\pm -$                          |  | CUSTOMER DRAWING          |   |                      |                 |
| 4 PLC $\pm -$                          |  | SCALE NTS                 |   |                      |                 |
| ANGLES $\pm 5^\circ$                   |  | SHEET 1 OF 1              |   |                      |                 |
| MATERIAL -                             |  | REV P                     |   |                      |                 |
| FINISH -                               |  |                           |   |                      |                 |

# Mouser Electronics

Authorized Distributor

Click to View Pricing, Inventory, Delivery & Lifecycle Information:

[TE Connectivity:](#)

[THS1515RJ](#)