

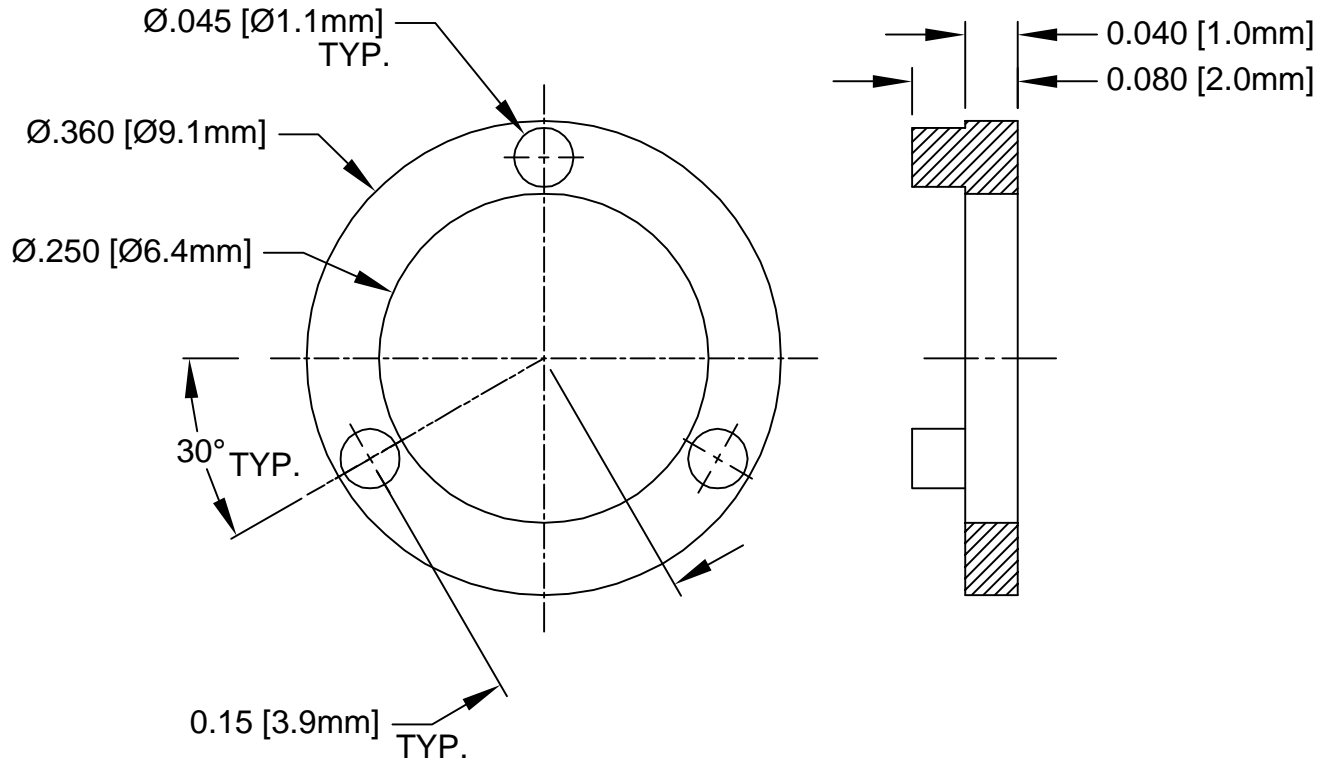

REV.	DESCRIPTION	DATE	APPROVED
A	Engineering Update w/o Changes	02/23/04	M. C.



- 2. MATERIAL: NYLON 6/6, 94V-2, WHITE. BIVAR MATERIAL CODE 04-WE. BASF ULTRAMID NYLON 6/6 A3K WHITE.
- 1. GENERAL SPECIFICATIONS: BIVAR MOLDED COMPONENT SPECIFICATION BV00-E101.

STANDARD TOLERANCE (UNLESS OTHERWISE SPECIFIED)		 4 THOMAS, IRVINE, CA. 92618 TEL: (949) 951-8808 FAX: (949) 951-3974	
DECIMALS	ANGULAR		
.X $\pm .1$	$X^\circ \pm 1^\circ$		TITLE: PERM-O-PAD TO-5 AND IC MOUNT
.XX $\pm .01$			PART NO: 600-080
.XXX $\pm .005$		CHECKED: D. Green	DATE: 02/23/04
DESIGNED: Shane Irving		DATE: 11/09/99	CAGE CODE : 32559 SHEET # 1 OF 1
CAD GENERATED DOCUMENT, DO NOT MEASURE DRAWING.			

# Mouser Electronics

Authorized Distributor

Click to View Pricing, Inventory, Delivery & Lifecycle Information:

[BIVAR:](#)

[600-080](#)