

THIS DRAWING IS UNPUBLISHED. RELEASED FOR PUBLICATION 2011
 © COPYRIGHT 2011 BY - ALL RIGHTS RESERVED.

LOC	DIST	REVISIONS			
P	LTR	DESCRIPTION	DATE	DWN	APVD
ES	-	A	RELEASED	04FAB2013	R.W S.Y

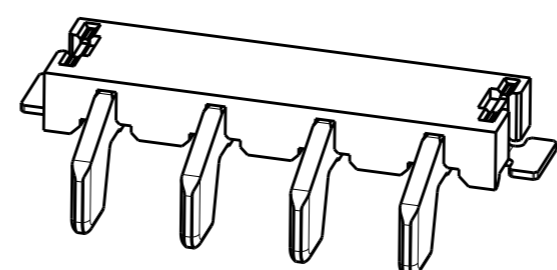
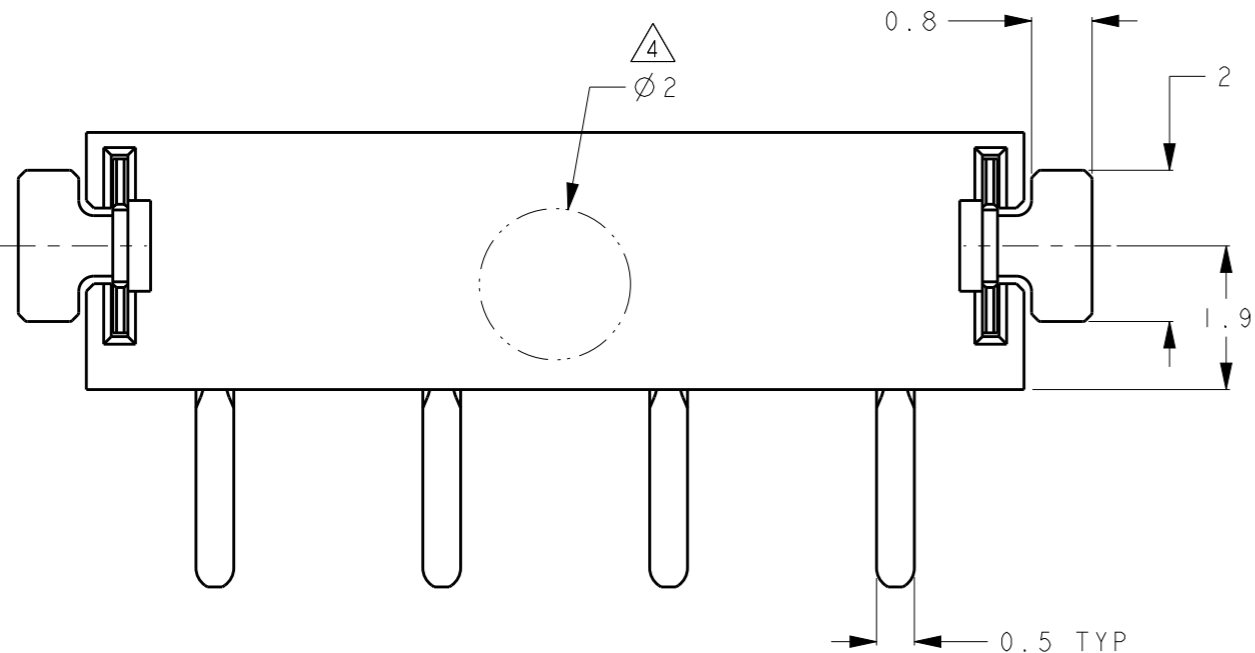

SCALE 5:1

- 1 MATERIAL
 CONTACT: COPPER ALLOY
 HOUSING: THERMOPLASTIC, BLACK
 SOLDER PEG: COPPER ALLOY
- 2 FINISH
 CONTACT: NICKEL ALL OVER UNDER PLATING, 3um MIN.
 GOLD PLATING AT CONTACT AREA, 0.76um MIN.
 GOLD FLASH PLATING AT LEAD AREA, 0.05~0.2um
 SOLDER PEG: NICKEL ALL OVER UNDER PLATING, 1.27um MIN
 TIN PLATING ALL OVER, 2-5um
- 3 COPLANARITY 0.08MAX.
- 4 PICKING AREA

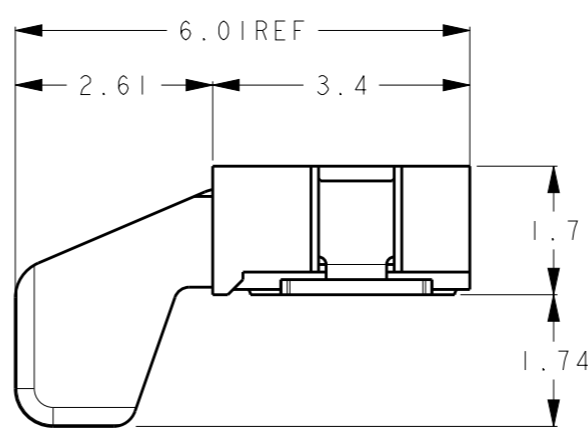
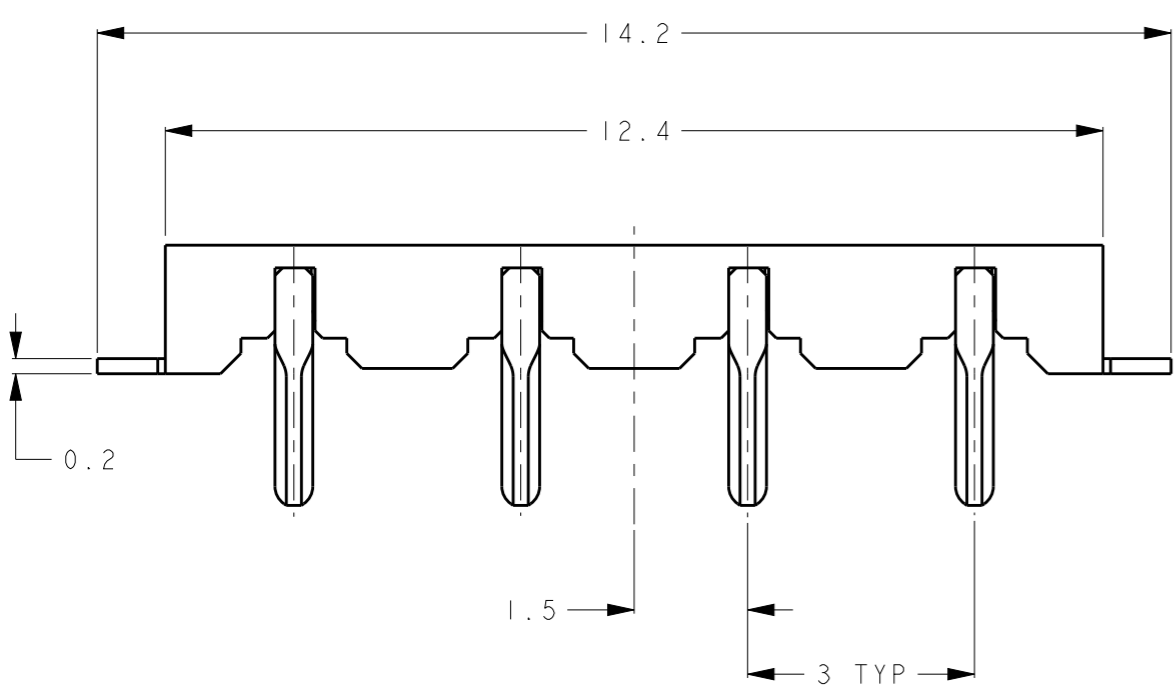

2134758-1: AS SHOWN

THIS DRAWING IS A CONTROLLED DOCUMENT.		DWN R. WANG	04FAB2013	TE Connectivity	
DIMENSIONS: mm		CHK W. HE	04FAB2013		
TOLERANCES UNLESS OTHERWISE SPECIFIED: ± 0.15		APVD S. YAO	04FAB2013	NAME FLOATING BATTERY INTERCONNECTION SYSTEM PLUG ASSEMBLY 4P OFFSET TYPE	
0 PLC ± 1 PLC ± 2 PLC ± 3 PLC ± 4 PLC ± ANGLES ±3°		PRODUCT SPEC 108-78834-1		SIZE A300779	
MATERIAL 1		FINISH 2		DRAWING NO C-2134758	
WEIGHT 0.24 g		Customer Drawing		RESTRICTED TO -	
SCALE 4:1		SHEET 1 OF 3		REV A	

THIS DRAWING IS UNPUBLISHED.

RELEASED FOR PUBLICATION

2011

© COPYRIGHT 2011 BY -

ALL RIGHTS RESERVED.

LOC
ES

DIST
-

REVISIONS

P	LTR	DESCRIPTION	DATE	DWN	APVD
-	-	SEE SHEET 1	-	-	-

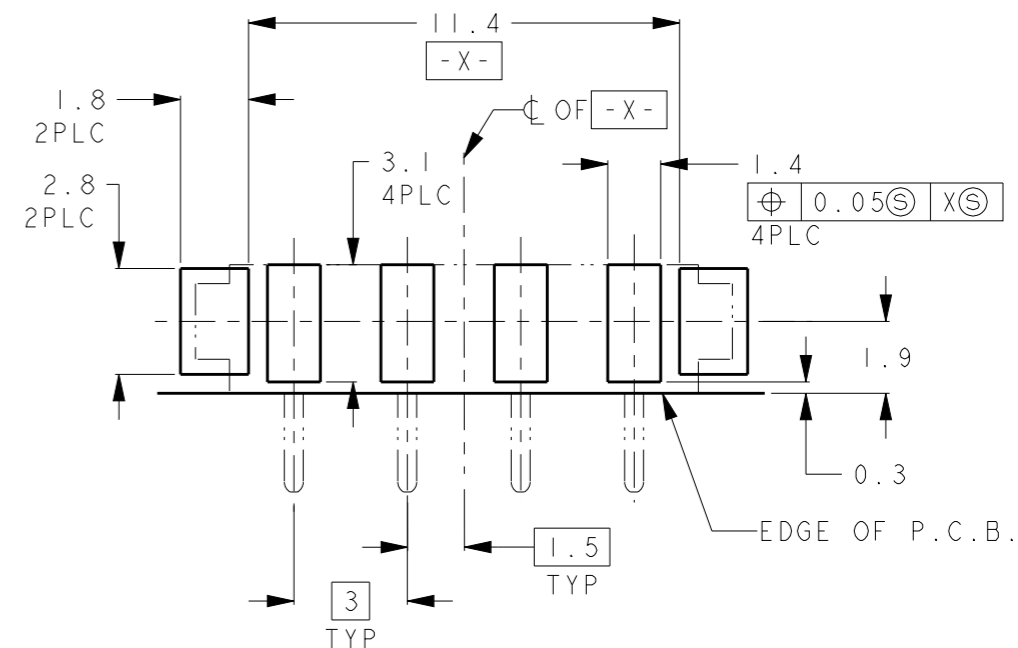
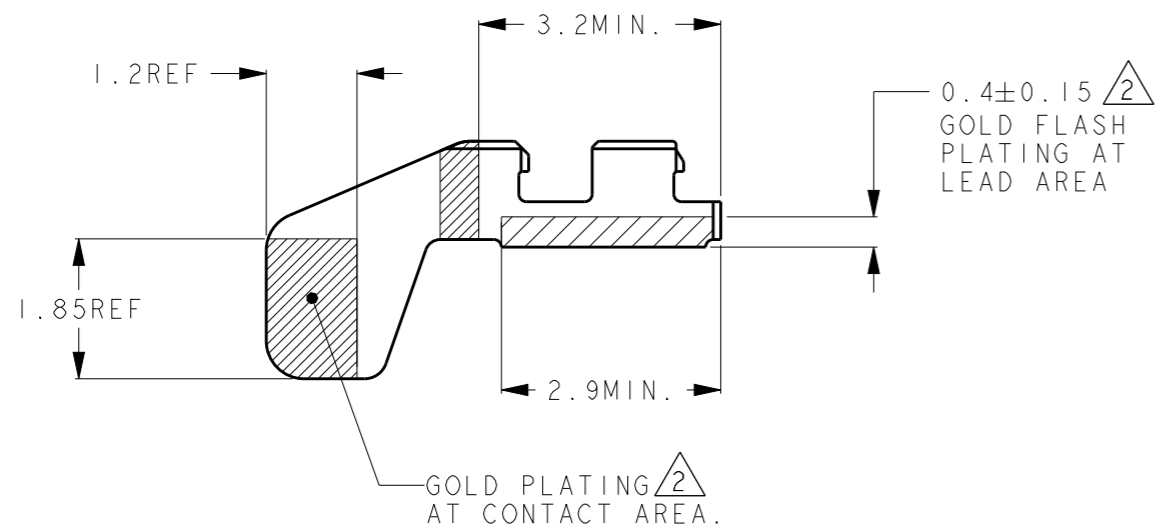

REFERENCE P.C. BOARD LAYOUT
(GENERAL TOLERANCE: ±0.05, SCALE 5:1)

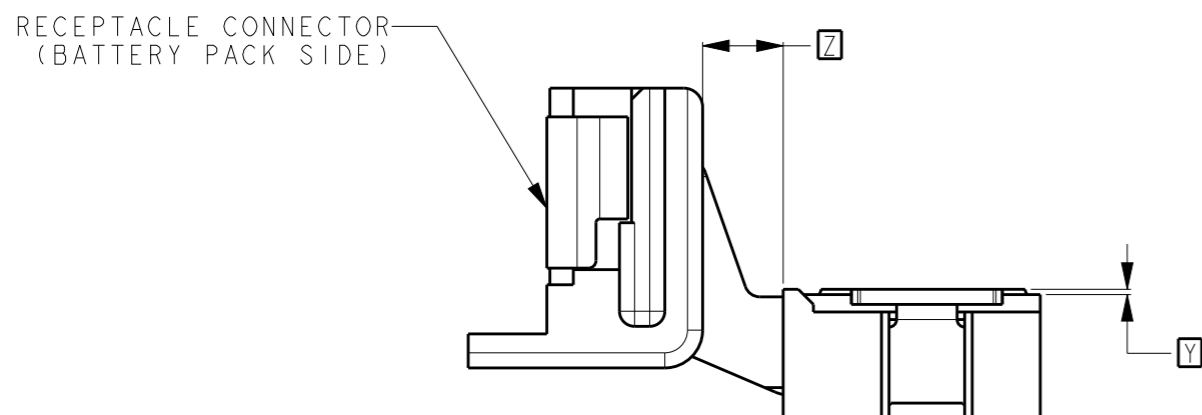

SCALE 10:1

CONNECTOR POSITION
CONTACT TE FOR GUIDELINES

THIS DRAWING IS A CONTROLLED DOCUMENT.

DIMENSIONS: mm		TOLERANCES UNLESS OTHERWISE SPECIFIED: ± 0.15	
\emptyset PLC	±	1 PLC	±
2 PLC	±	3 PLC	±
4 PLC	±	ANGLES	± 3°
MATERIAL		FINISH	

DWN
CHK
APVD
PRODUCT SPEC
APPLICATION SPEC
WEIGHT
Customer Drawing



NAME
FLOATING BATTERY INTERCONNECTION SYSTEM
PLUG ASSEMBLY 4P OFFSET TYPE

SIZE	CAGE CODE	DRAWING NO	RESTRICTED TO
A300779	C=2134758		-

SCALE 4:1	SHEET 2 OF 3	REV A
-----------	--------------	-------

THIS DRAWING IS UNPUBLISHED. RELEASED FOR PUBLICATION 2011
 © COPYRIGHT 2011 BY - ALL RIGHTS RESERVED.

LOC ES DIST -

REVISIONS					
P	LTR	DESCRIPTION	DATE	DWN	APVD
-	-	SEE SHEET 1	-	-	-

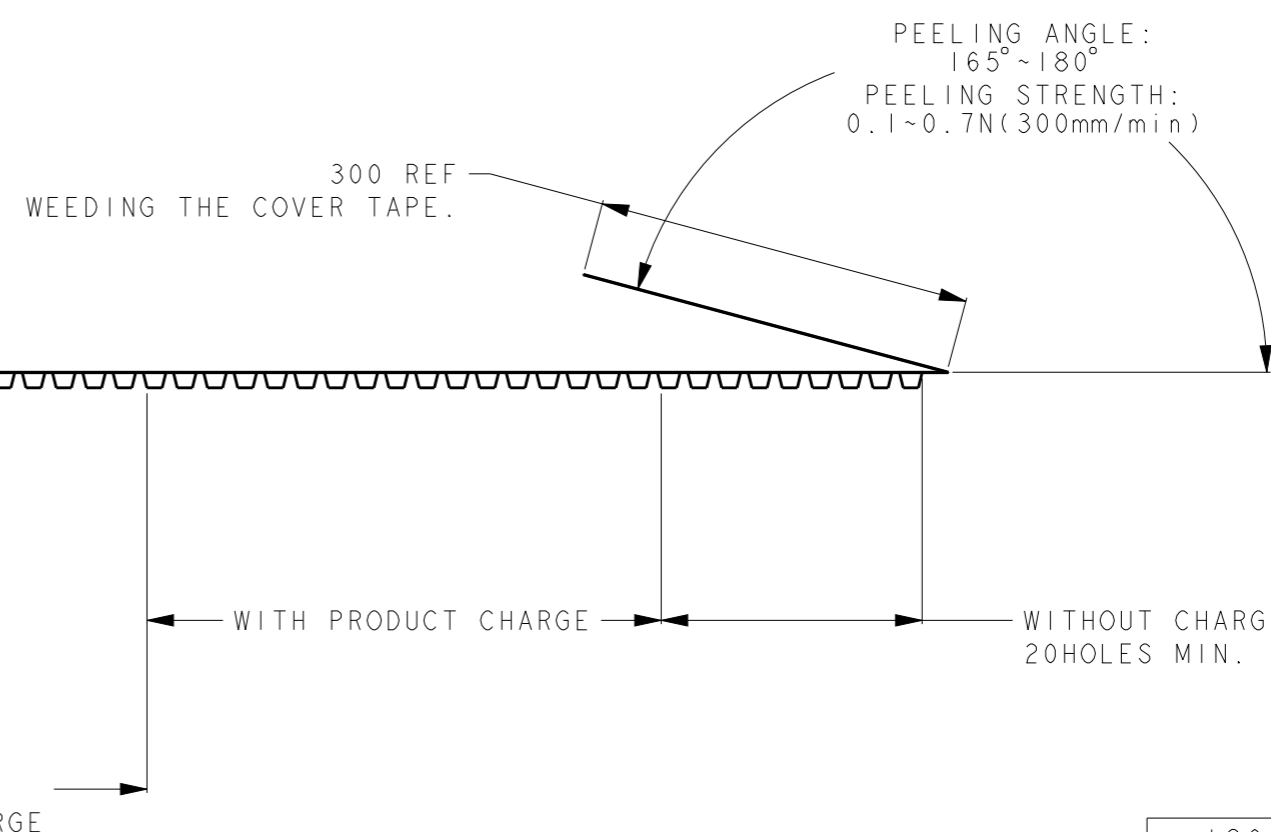
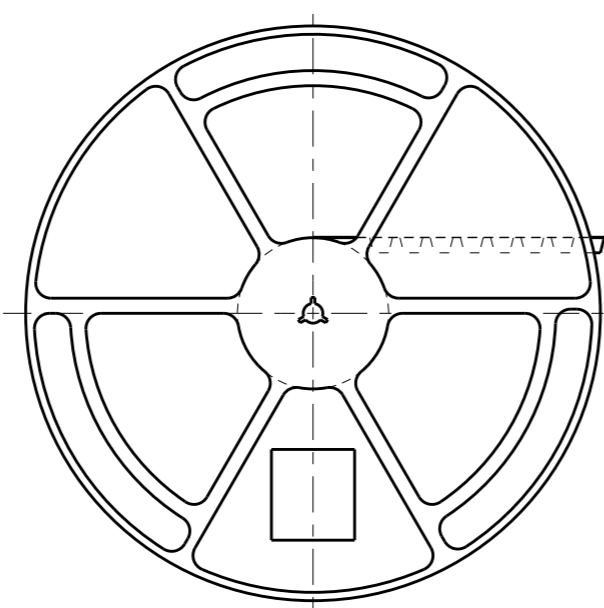
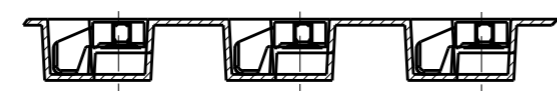
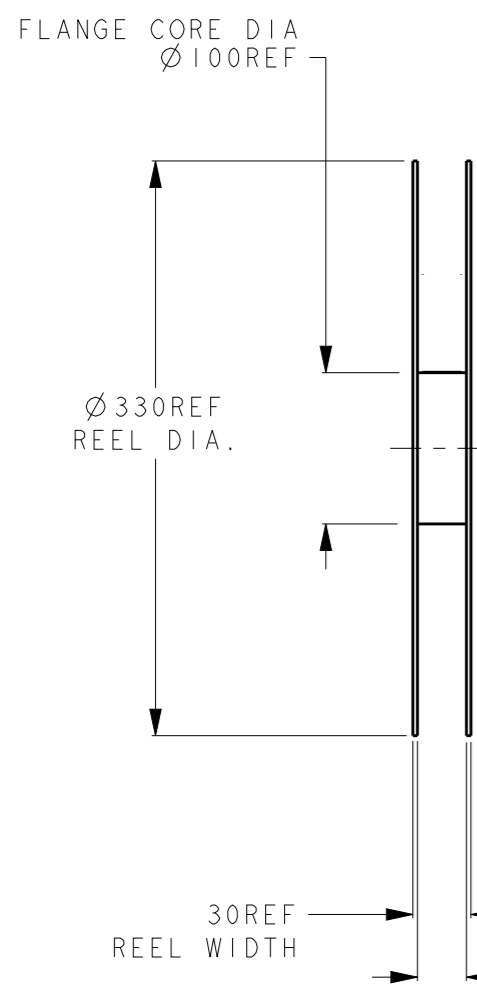
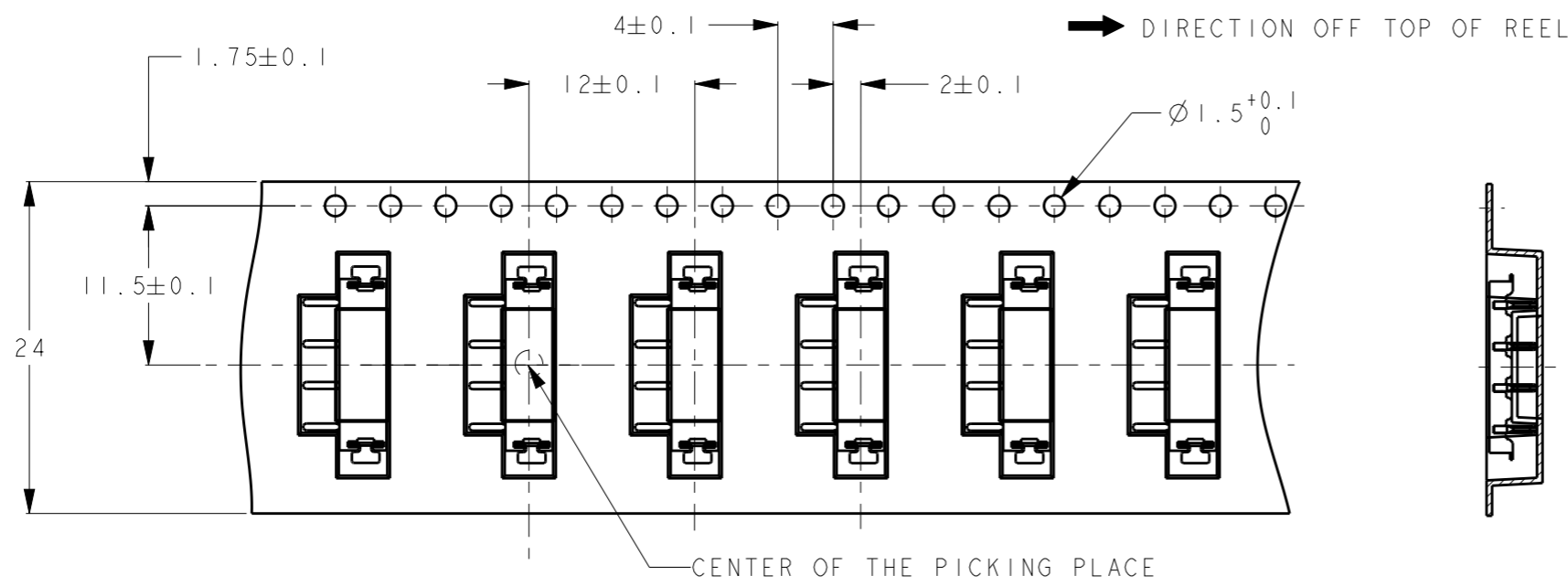

1200	2134758-1
QTY/REEL	P/N

THIS DRAWING IS A CONTROLLED DOCUMENT.	
DIMENSIONS: mm	TOLERANCES UNLESS OTHERWISE SPECIFIED: ±0.3
	0 PLC ±
	1 PLC ±
	2 PLC ±
	3 PLC ±
	4 PLC ±
	ANGLES ±3°
MATERIAL	FINISH

DWN
CHK
APVD
PRODUCT SPEC
APPLICATION SPEC
WEIGHT
Customer Drawing

STE TE Connectivity

NAME
 FLOATING BATTERY INTERCONNECTION SYSTEM
 PLUG ASSEMBLY 4P OFFSET TYPE

SIZE	CAGE CODE	DRAWING NO	RESTRICTED TO
A300779	C=2134758		-

SCALE NTS SHEET 3 OF 3 REV A

Mouser Electronics

Authorized Distributor

Click to View Pricing, Inventory, Delivery & Lifecycle Information:

[TE Connectivity:](#)

[2134758-1](#)