

FTDI Chip

VI800A-N485U Datasheet Plug in accessory for VM800P Embedded Video Engine Plus module

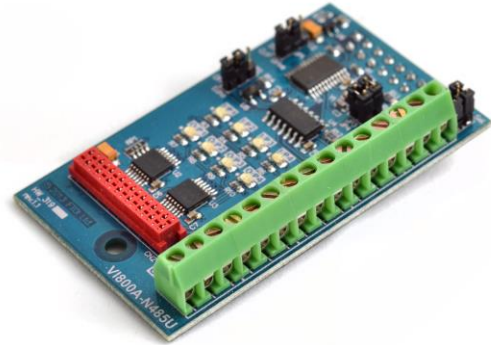

1 Introduction

The VI800A-N485U is a plug in accessory for the VM800P Plus module, which is used to develop and demonstrate the functionality of the FT800 Embedded Video Engine, EVE.

This module behaves as an SPI to RS485 bridge on the VM800P Plus module.

1.1 Features

- Connects to the VM800P Plus module using an SPI slave interface
- SPI slave interface is converted to RS485 interface
- 4 GPIO inputs and 4 GPIO outputs
- 8 LEDs to indicate the input and output status
- 3.3 V IO with 5 V tolerant buffers
- Screw connector to connect the RS485 signals, GPIO inputs and GPIO outputs
- IO interface to connect the RS485 signals, GPIO inputs and GPIO outputs
- Powered from the VM800P module

Neither the whole nor any part of the information contained in, or the product described in this manual, may be adapted or reproduced in any material or electronic form without the prior written consent of the copyright holder. This product and its documentation are supplied on an as-is basis and no warranty as to their suitability for any particular purpose is either made or implied. Future Technology Devices International Ltd will not accept any claim for damages howsoever arising as a result of use or failure of this product. Your statutory rights are not affected. This product or any variant of it is not intended for use in any medical appliance, device or system in which the failure of the product might reasonably be expected to result in personal injury. This document provides preliminary information that may be subject to change without notice. No freedom to use patents or other intellectual property rights is implied by the publication of this document. Future Technology Devices International Ltd, Unit 1, 2 Seaward Place, Centurion Business Park, Glasgow G41 1HH United Kingdom. Scotland Registered Company Number: SC136640

2 Ordering Information

Part No.	Description
VI800A-N485U	VI800A RS485 module, plug accessory for the VM800P Plus module

Table 2-1 – Ordering information

Table of Contents

1	Introduction	1
1.1	Features.....	1
2	Ordering Information	2
3	Hardware Description	4
3.1	VI800A-N485U module	4
3.2	Physical Descriptions	5
3.2.1	PCB Dimensions	5
3.2.2	VI800A-N485U Connectors	7
3.2.3	VI800A-N485U Components	10
4	Board Schematics.....	11
5	Hardware Setup Guide	12
5.1	Power Configuration	12
5.2	RS485 Interface connection.....	12
6	Contact Information.....	13
Appendix A – References		12
Document References		12
Appendix B - List of Figures and Tables		13
List of Figures		13
List of Tables.....		13
Appendix C – Revision History		14

3 Hardware Description

Please refer to section **3.2.2** for connector settings. Some VI800A-N485U jumpers must be set to work properly with your system.

3.1 VI800A-N485U module

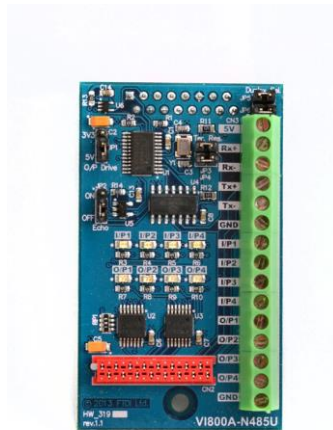

Figure 3-1 – VI800A-N485U module

The VI800A-N485U module is designed to connect directly with the VM800P Plus module.

The main functions of the VI800A N485U are as follows:

- Plug in accessory board for the VM800P Plus module.
- Interface to the VM800P Plus board as a SPI slave device.
- Connects with an external RS485 interface.
- Supports 4 GPIO inputs.
- Supports 4 GPIO outputs.
- Contains 8 LEDs.
- Powered by the VM800P Plus board.

3.2 Physical Descriptions

3.2.1 PCB Dimensions

The VI800A-N485U module PCB layout is illustrated in [Figure 3-2](#) and [Figure 3-3](#).

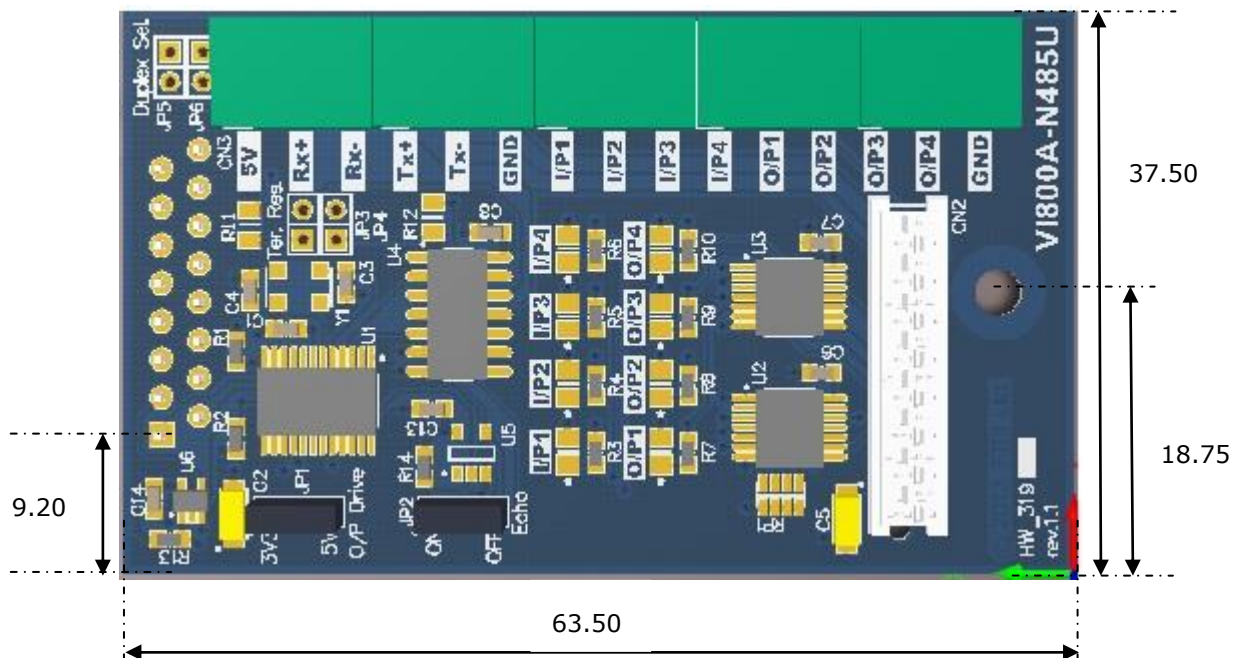

Figure 3-2 - VI800A-N485U module PCB Top view

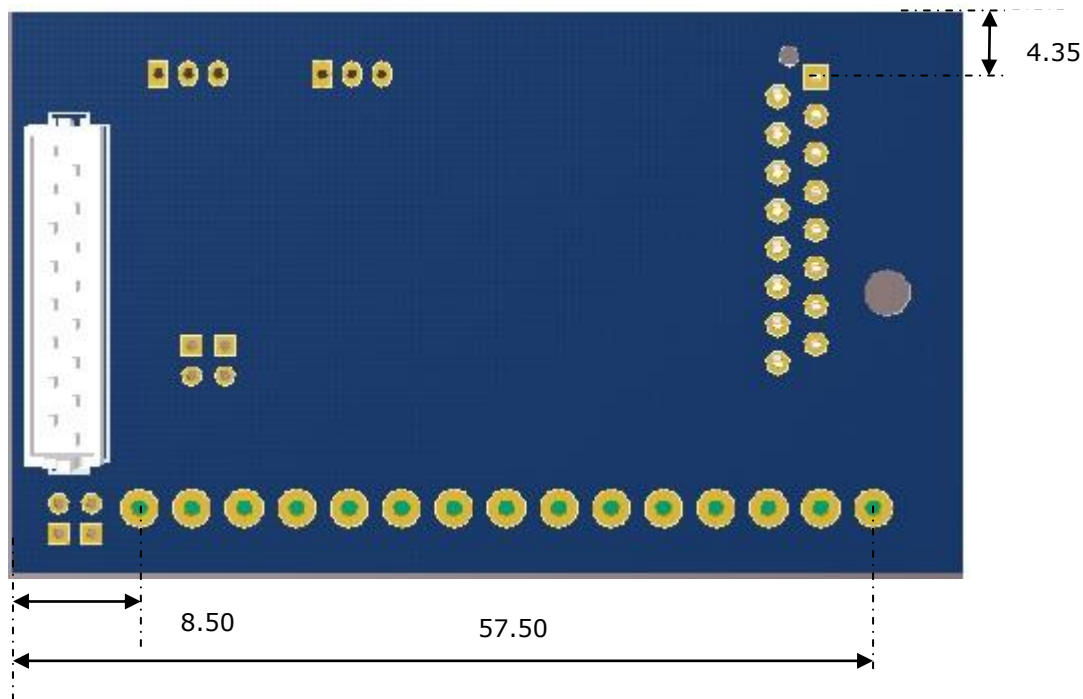

Figure 3-3 - VI800A-N485U module PCB Bottom view



Figure 3-4 - VI800A-N485U module PCB side view

All dimensions are in mm

3.2.2 VI800A-N485U Connectors

Connectors and jumpers are described in the following sections.

- **CN1- SPI Interface**

This is the interface where the SPI control and data signals are routed. There are also power and ground pins on this interface. This interface is used to connect the VI800A-N485U board to the VM800P Plus board.

Note:

This connector should be connected to J6 of the VM800P plus board.

Pin No.	Name	Type	Description
1	SCK	I	SPI Clock input, 3.3V (5V tolerant)
2	MOSI	I	Master Out Slave in, 3.3V (5V tolerant)
3	MISO	O	Master In Slave out, 5V
4	SS#	I	SPI Chip select, active low, 3.3V (5V tolerant)
5	INT0	O	Interrupt output active low, 3.3V
6	IO6	I	Daughter reset input, active low , 3.3V (5V tolerant)
7	AD4	IO	Address/Data Line 4
8	AD5	IO	Address/Data Line 5
9	3V3	P	3.3V power supply
10	5V	P	5V power supply
11	GND	P	Ground
12	RST#	I	Reset, active low
13	AD1	IO	Address/Data Line 1
14	NC	NA	Not Connected
15	AD3	IO	Address/Data Line 3
16	AD2	IO	Address/Data Line 2

Table 3-1 – CN1 Pinout

- **CN2- IO Interface(alternative to CN3)**

This is the interface where the RS485 connections, GPIO input and outputs are connected. There are also power and ground pins on this interface.

Pin No.	Name	Type	Description
1	3V3	P	3.3V power supply
2	5V	P	5V power supply
3	I/P1	I	Input 1
4	I/P2	I	Input 2
5	I/P3	I	Input 3
6	I/P4	I	Input 4
7	O/P1	O	Output 1

Pin No.	Name	Type	Description
8	O/P2	O	Output 2
9	O/P3	O	Output 3
10	O/P4	O	Output 4
11	GND	P	Ground
12	GND	P	Ground
13	Rx+	I	Receive Data non-inverting
14	Rx-	I	Receive Data inverting
15	Tx+	O	Transmit Data non-inverting
16	Tx-	O	Transmit Data inverting

Table 3-2 – CN2 Pinout

- **CN3- External Screw Connector(alternative to CN2)**

This is the interface where the RS485 connections, GPIO input and outputs are connected. There are also power and ground pins on this interface.

Pin No.	Name	Type	Description
1	5V	P	5V power supply
2	Rx+	I	Receive Data non-inverting
3	Rx-	I	Receive Data inverting
4	Tx+	O	Transmit Data non-inverting
5	Tx-	O	Transmit Data inverting
6	GND	P	Ground
7	I/P1	I	Input 1
8	I/P2	I	Input 2
9	I/P3	I	Input 3
10	I/P4	I	Input 4
11	O/P1	O	Output 1
12	O/P2	O	Output 2
13	O/P3	O	Output 3
14	O/P4	O	Output 4
15	GND	P	Ground

Table 3-3 – CN3 Pinout

- **JP1- Output Drive Select**

This jumper provides the option to select the power supply voltage for the inputs and outputs.

Jumper position	Description
Short pin 1-2	3.3V selected
Short pin 2-3	5V selected (default)

Table 3-4 – JP1 Pin options

- **JP2- Echo Enable**

This jumper selects whether data being transmitted is also echoed back. In half-duplex RS485 mode, the shared bi-directional RS485 lines mean that the VI800A-N485U can also normally receive a copy of any data which it sends.

When this jumper is set for echo enable, the receiver is always enabled and so the VI800A-N485U will receive a copy of any data it sends. When this jumper is set for echo disable, the receiver is disabled whenever the VI800A-N485U is transmitting and so the data is not echoed back.

Jumper position	Description
Short pin 1-2	Echo enabled
Short pin 2-3	Echo disabled

Table 3-5 – JP2 Pin options

- **JP3 and JP4 - Termination**

These jumpers select termination of the Rx lines (JP3) and Tx lines (JP4).

Fitting the jumper JP3 will connect a 120 Ohm resistor between RX+ and RX-.

Fitting the jumper JP4 will connect a 120 Ohm resistor between TX+ and TX-.

When in half-duplex mode, and if termination is required, only one jumper (e.g. JP3 but not JP4) should be fitted. If both jumpers were fitted in this mode, the two resistors would effectively be in parallel giving 60 Ohms between Data + and Data - instead of the intended 120 Ohms. This could, in combination with the termination at the other end of the bus, result in overloading of the line drivers throughout the bus.

Jumper position	Description
Short JP3	Termination resistor between RX+ and RX-
Short JP4	Termination resistor between TX+ and TX-

Table 3-6 – JP3 and JP4

- **JP5 and JP6 - Duplex/Simplex Enable**

These jumpers select between half-duplex and full-duplex operation. Both jumpers would either be fitted or not fitted at the same time.

Jumper 5 shorts the full-duplex signals RX+ and TX+ to form a single Data+ line for half-duplex.

Jumper 6 shorts the full-duplex signals RX- and TX- to form a single Data- line for half-duplex.

When in half-duplex mode, the Data+ signal of the external RS485 bus can be connected to either the TX+ or the RX+ terminal of the terminal block. Likewise the Data- signal of the external RS485 bus can be connected to either the TX- or the RX- terminal of the terminal block.

Jumper position	Description
Short JP5 and Short JP6	Half Duplex mode
Open JP5 and Open JP6	Full Duplex mode

Table 3-7 – JP5 and JP6

3.2.3 VI800A-N485U Components

- **U1 – SC16IS760**

This converts the SPI signals from the VM800P Plus board to UART TTL signals.

- **U4 – ZT3073LEEN**

This converts the UART signals from the TTL level to RS485 signal.

- **LED1 – LED4**

Indicates the status of GPIO inputs. Illuminate when the GPIO line is logic 0.

- **LED5 –LED8**

Indicates the status of the GPIO outputs. Illuminate when the GPIO line is logic 0.

4 Board Schematics

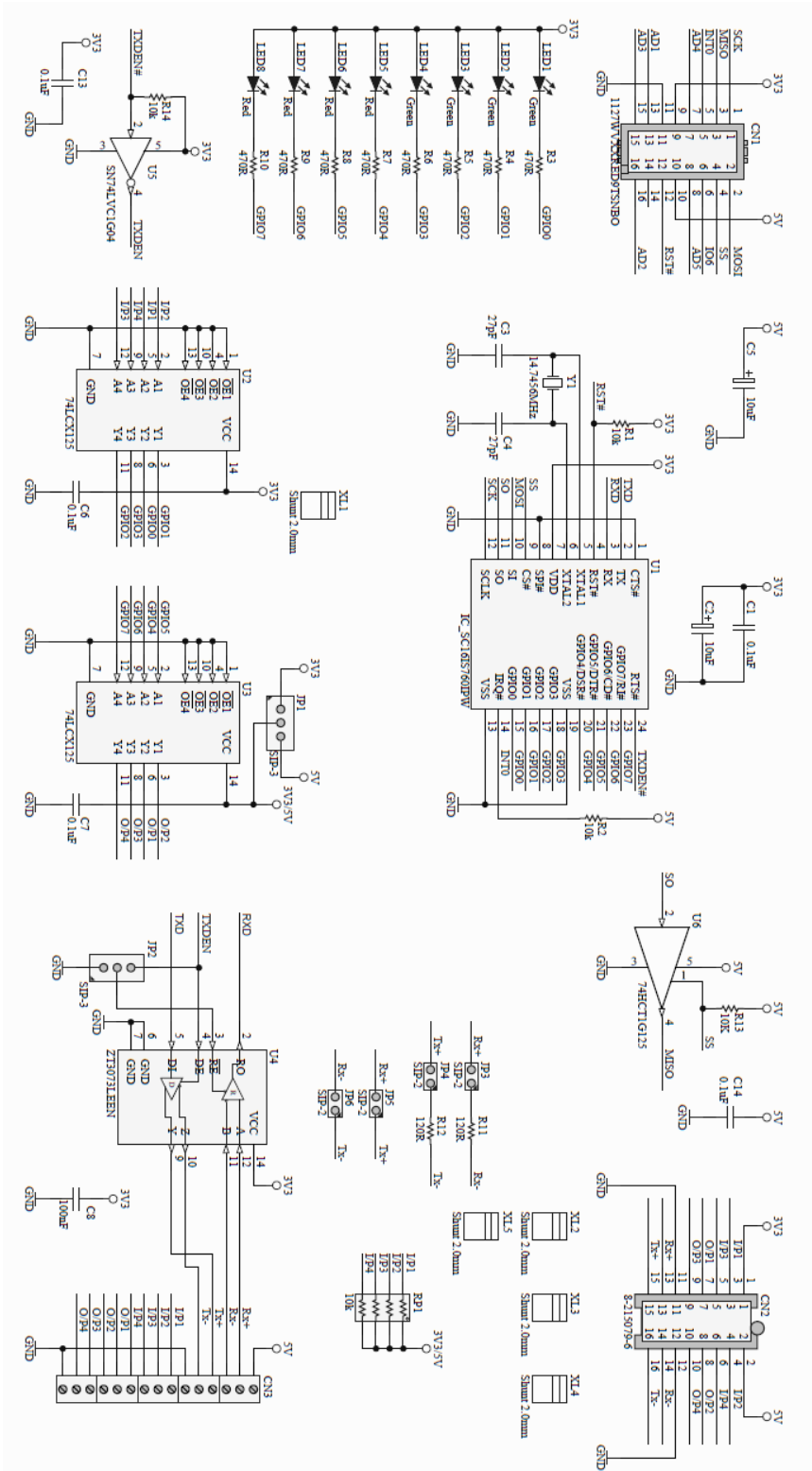

Figure 4-1 - VI800A-N485U Schematics

5 Hardware Setup Guide

5.1 Power Configuration

The board is powered from the VM800P Plus board. The CN1 connector on the VI800A-N485U board should be connected to the J6 connector of the VM800P Plus board as shown in the Figure 5-1.

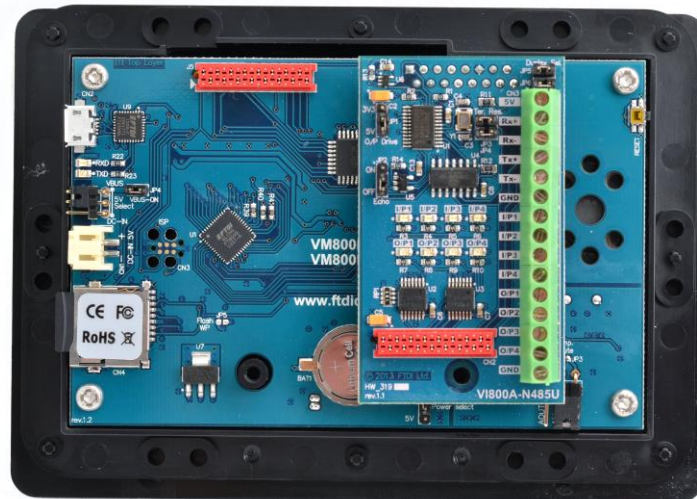

Figure 5-1 - VI800A-N485U module connected to VM800P Plus module

5.2 RS485 Interface connection

When the VI800A-N485U is connected to a RS485 device the following connection is used.

The Tx+ signal on CN3 is connected to the Rx+ signal on the external RS485 device.

The Tx- signal on CN3 is connected to the Rx- signal on the external RS485 device.

The Rx+ signal on CN3 is connected to the Tx+ signal on the external RS485 device.

The Rx- signal on CN3 is connected to the Tx- signal on the external RS485 device.

The GND signal on CN3 is connected to the GND signal on the external RS485 device.

The output from the external device is connected to the inputs I/P1, I/P2, I/P3 and I/P4 on the CN3.

The input from the external device is connected to the outputs O/P1, O/P2, O/P3 and O/P4 on the CN3.

The LEDs LED1 to LED8 are used to display the status of the inputs and outputs.

This interface is used to interface the VM800P Plus module to the devices having RS485 and GPIO interfaces.

6 Contact Information

Head Quarters – Singapore

Bridgetek Pte Ltd
178 Paya Lebar Road, #07-03
Singapore 409030
Tel: +65 6547 4827
Fax: +65 6841 6071

E-mail (Sales) sales.apac@brtchip.com
E-mail (Support) support.apac@brtchip.com

Branch Office – Taipei, Taiwan

Bridgetek Pte Ltd, Taiwan Branch
2 Floor, No. 516, Sec. 1, Nei Hu Road, Nei Hu District
Taipei 114
Taiwan, R.O.C.
Tel: +886 (2) 8797 5691
Fax: +886 (2) 8751 9737

E-mail (Sales) sales.apac@brtchip.com
E-mail (Support) support.apac@brtchip.com

Branch Office - Glasgow, United Kingdom

Bridgetek Pte. Ltd.
Unit 1, 2 Seaward Place, Centurion Business Park
Glasgow G41 1HH
United Kingdom
Tel: +44 (0) 141 429 2777
Fax: +44 (0) 141 429 2758

E-mail (Sales) sales.emea@brtchip.com
E-mail (Support) support.emea@brtchip.com

Branch Office – Vietnam

Bridgetek VietNam Company Limited
Lutaco Tower Building, 5th Floor, 173A Nguyen Van
Troj,
Ward 11, Phu Nhuan District,
Ho Chi Minh City, Vietnam
Tel : 08 38453222
Fax : 08 38455222

E-mail (Sales) sales.apac@brtchip.com
E-mail (Support) support.apac@brtchip.com

Web Site

<http://brtchip.com/>

Distributor and Sales Representatives

Please visit the Sales Network page of the [Bridgetek Web site](#) for the contact details of our distributor(s) and sales representative(s) in your country.

System and equipment manufacturers and designers are responsible to ensure that their systems, and any Future Technology Devices International Ltd (FTDI) devices incorporated in their systems, meet all applicable safety, regulatory and system-level performance requirements. All application-related information in this document (including application descriptions, suggested FTDI devices and other materials) is provided for reference only. While FTDI has taken care to assure it is accurate, this information is subject to customer confirmation, and FTDI disclaims all liability for system designs and for any applications assistance provided by FTDI. Use of FTDI devices in life support and/or safety applications is entirely at the user's risk, and the user agrees to defend, indemnify and hold harmless FTDI from any and all damages, claims, suits or expense resulting from such use. This document is subject to change without notice. No freedom to use patents or other intellectual property rights is implied by the publication of this document. Neither the whole nor any part of the information contained in, or the product described in this document, may be adapted or reproduced in any material or electronic form without the prior written consent of the copyright holder. Future Technology Devices International Ltd, Unit 1, 2 Seaward Place, Centurion Business Park, Glasgow G41 1HH, United Kingdom. Scotland Registered Company Number: SC136640

Appendix A – References

Document References

VM800P datasheet: [VM800P Plus board](#)

FT800 datasheet: [FT800 Embedded Video Engine](#)

FT800 software programming guide: [FT800 Programmer Guide](#)

FT800 sample application notes:

[AN_246_VM800CB_SampleAPP_Arduino_Introduction](#)

[AN_275_FT800_Example_with_Arduino.pdf](#)

[AN_318_Arduino_Library_for_FT800_Series](#)

[AN_330_VI800A_TTL_232U_N485U_ArduinoLibrary_Sample](#)

Appendix B - List of Figures and Tables

List of Figures

Figure 3-1 – VI800A-N485U module.....	4
Figure 3-2 - VI800A-N485U module PCB Top view	5
Figure 3-3 - VI800A-N485U module PCB Bottom view	5
Figure 3-4 - VI800A-N485U module PCB side view.....	6
Figure 4-1 - VI800A-N485U Schematics.....	11
Figure 5-1 - VI800A-N485U module connected to VM800P Plus module	12

List of Tables

Table 2-1 – Ordering information.....	2
Table 3-1 – CN1 Pinout.....	7
Table 3-2 – CN2 Pinout.....	8
Table 3-3 – CN3 Pinout.....	8
Table 3-4 – JP1 Pin options	9
Table 3-5 – JP2 Pin options	9
Table 3-6 – JP3 and JP4.....	9
Table 3-7 – JP5 and JP6.....	10

Appendix C – Revision History

Document Title: VI800A_N485U Datasheet
Document Reference No.: BRT_000020
Clearance No.: BRT#015
Product Page: <http://brtchip.com/product>
Document Feedback: [Send Feedback](#)

Revision	Changes	Date
Version 1.0	Initial Release	2014-10-14
Version 1.1	Added height dimensions	2014-10-20
Version 1.2	Dual branding to reflect the migration of the product to the Bridgetek name – logo changed, copyright changed, contact information changed	2016-09-15

Mouser Electronics

Authorized Distributor

Click to View Pricing, Inventory, Delivery & Lifecycle Information:

[Bridgetek:](#)

[VI800A-N485U](#)