

STK984-090A-E

20A/40V Integrated Power Module in SIP23 package

The STK984-090A-E is a fully-integrated inverter power stage consisting of a gate driver, six MOSFET's and a high-side shunt resistor, suitable for driving permanent magnet synchronous (PMSM) motors and brushless-DC (BLDC) motors. The MOSFET's are configured in a 3-phase bridge with a single drain connection for the lower legs. The power stage has a full range of protection functions including cross-conduction protection, external shutdown and undervoltage lockout.

Features

- Module with six 40V/20A MOSFETs, driver and sense resistor
- 59.8mm × 26.7mm single in-line package with 90° lead bend
- Built-in charge pump for operation with low battery voltage
- Over-current protection on both high-side and low-side MOSFETs
- Over-temperature shutdown
- Undervoltage and overvoltage shutdown for defined operation at all input voltages
- Integrated high-side resistor for external current sensing

Typical Applications

- Automotive Fans
- Automotive Pumps

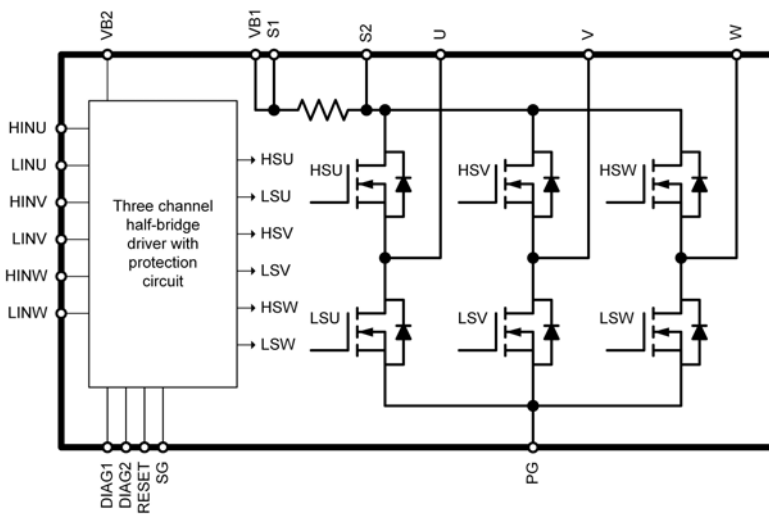

Figure 1: Functional Diagram



ON Semiconductor®

www.onsemi.com

PACKAGE PICTURE



SIP23 / SIP2E 2nd

MARKING DIAGRAM

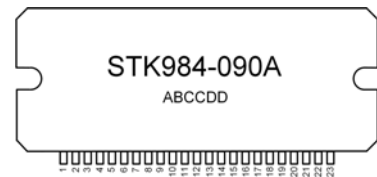

STK984-090A-E = Specific Device Code
 A = Year
 B = Month
 C = Production Site
 DD = Factory Lot Code

PIN CONNECTIONS

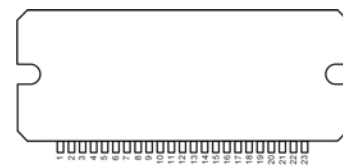

ORDERING INFORMATION

Device	Package	Shipping (Qty / Packing)
STK984-090A-E	SIP23 / SIP2E 2nd (Pb-Free)	9 / Tube

STK984-090A-E

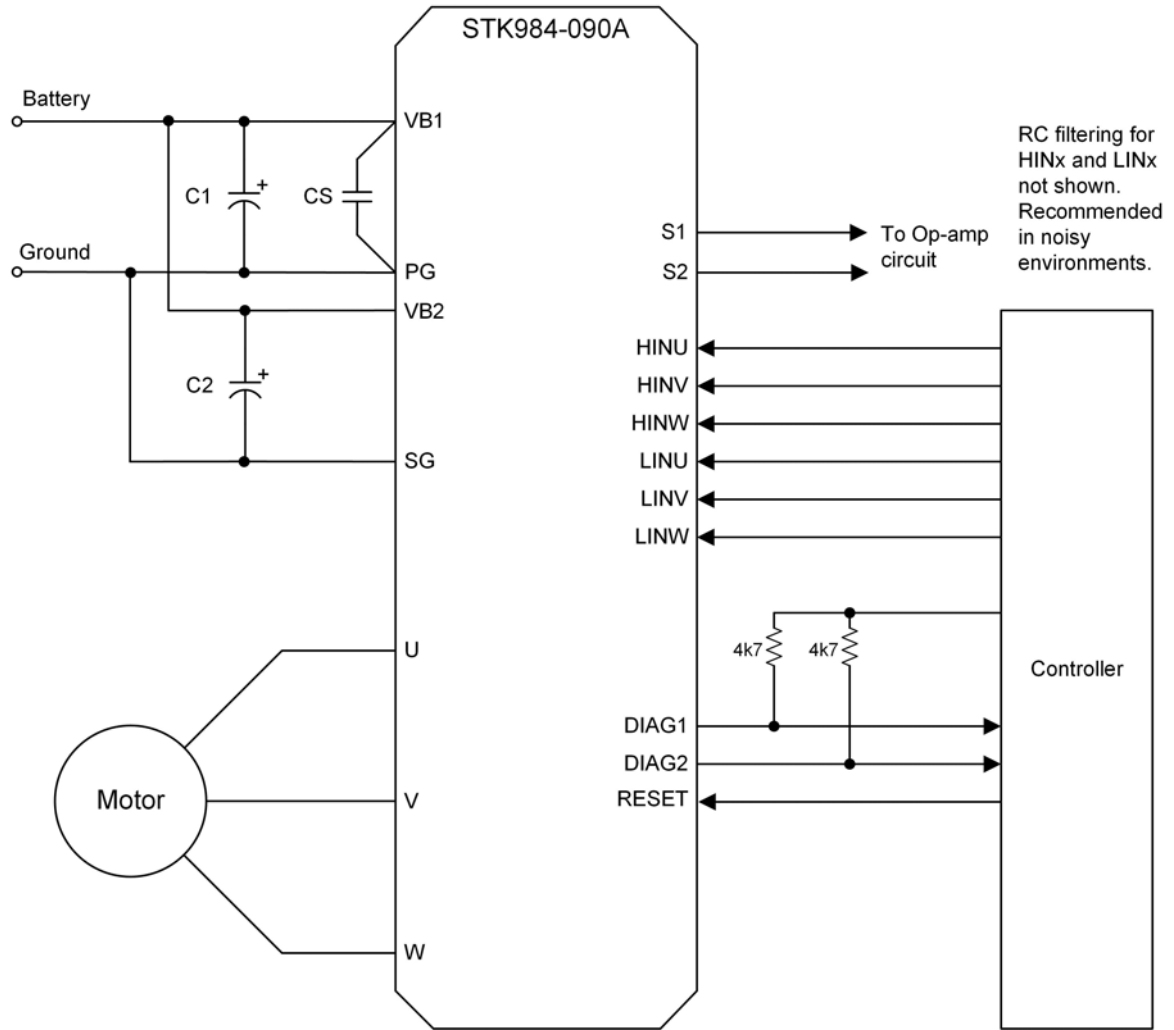

Figure 2: Application Schematic

STK984-090A-E

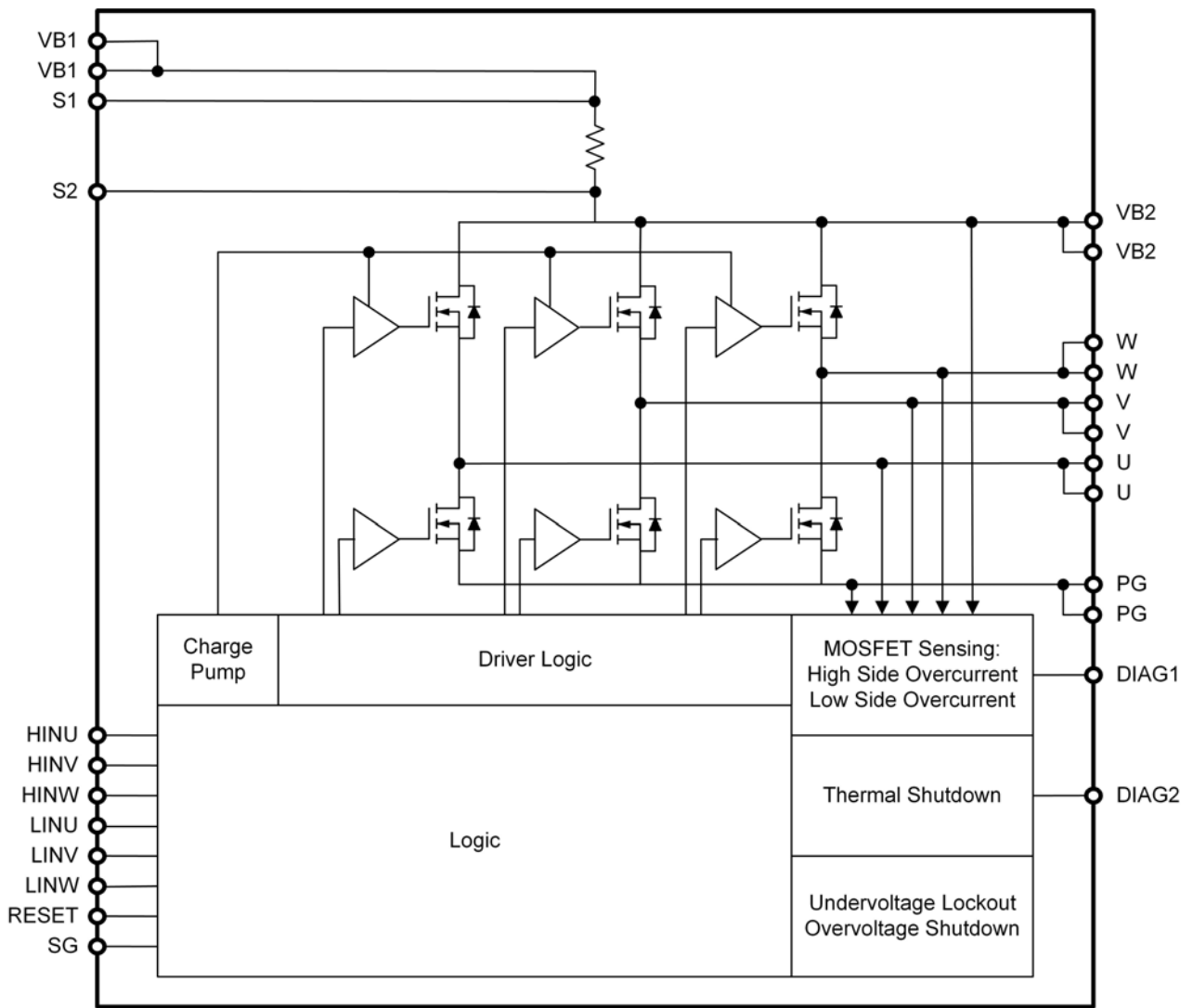

Figure 3: Simplified Block Diagram

STK984-090A-E

PIN FUNCTION DESCRIPTION

Pin Number	Pin Name	Description
1	VB2	Control System Power
2	SG	Control System GND
3	RESET	RESET Terminal
4	HINU	Driving Signal Input Upper U-phase
5	HINV	Driving Signal Input Upper V-phase
6	HINW	Driving Signal Input Upper W-phase
7	LINU	Driving Signal Input Lower U-phase
8	LINV	Driving Signal Input Lower V-phase
9	LINW	Driving Signal Input Lower W-phase
10	DIAG1	Fault Diagnosis Output 1 (Overcurrent)
11	DIAG2	Fault Diagnosis Output 2 (Over Temperature)
12	U	U-phase Output
13	U	U-phase Output
14	V	V-phase Output
15	V	V-phase Output
16	W	W-phase Output
17	W	W-phase Output
18	PG	Power System GND
19	PG	Power System GND
20	VB1	Power System Supply
21	VB1	Power System Supply
22	S1	Current Sense Resistor Sensing (+) terminal
23	S2	Current Sense Resistor Sensing (-) terminal

Table 1: Pin Function Description

STK984-090A-E

ABSOLUTE MAXIMUM RATINGS (Notes 1, 2)

Rating	Symbol	Conditions	Value	Unit
Supply Voltage	VB1 max	VB1 to PG	-0.3 to 40	V
	VB2 max	VB2 to SG	-0.3 to 40	V
Control Input Voltage	Vin max	HINx, LINx to SG (x=U,V,W)	-0.3 to 6	V
DIAG Terminal Voltage	VDIAG	DIAG1, DIAG2 to SG	-0.3 to 6	V
Drain Current	Id max	DC	20	A
		Pulse (Single 10 μ s pulse)	180	A
Junction Temperature	Tjmax	Semiconductor Device	150	$^{\circ}$ C
Storage Temperature	Tstg		-40 to +125	$^{\circ}$ C

1. Stresses exceeding those listed in the Maximum Ratings table may damage the device. If any of these limits are exceeded, device functionality should not be assumed, damage may occur and reliability may be affected.
2. Refer to ELECTRICAL CHARACTERISTICS, RECOMMENDED OPERATING RANGES and/or APPLICATION INFORMATION for Safe Operating parameters.

RECOMMENDED OPERATING RANGES (Note 3)

Rating	Symbol	Test Conditions	Min	Typ	Max	Unit
Supply Voltage	VB1	VB1 to PG	8	13.5	18	V
	VB2	VB2 to SG	8	13.5	18	V
Output Current	Io	120deg Excitation Method with 100% duty cycle	-	-	20	A
Operating Substrate Temperature	Tc		-40	-	125	$^{\circ}$ C
Drive PWM Frequency	fo	Duty cycle 10% to 90%, or 100%	-	-	20	kHz

3. Functional operation above the stresses listed in the Recommended Operating Ranges is not implied. Extended exposure to stresses beyond the Recommended Operating Ranges limits may affect device reliability.

STK984-090A-E

ELECTRICAL CHARACTERISTICS (Note 4)

at Ta = 25°C, VB1, VB2 = 13.5V unless otherwise specified

Parameter	Test Conditions	Symbol	Min	Typ	Max	Unit
-----------	-----------------	--------	-----	-----	-----	------

Power output section

Current consumption (Control system)	VB1=16V, VB2=16V	I _{cc}	-	10	15	mA
Output saturation voltage	I _O =20A. VB1 to U, V, W	V _{DS(sat)}	-	0.3	0.5	V
	I _O =20A. U, V, W to PG		-	0.2	0.4	V
Current sensing resistor		R _s	2.91	3.00	3.09	mΩ
Time delay (ON)	I _O =20A for U, V, W low to high	t _{d(on)}	0.9	1.8	2.8	μs
	I _O =20A for U, V, W high to low		0.9	1.9	3.0	μs
Rise time	I _O =20A	t _r	-	0.3	-	μs
Time delay (OFF)	I _O =20A for U, V, W high to low	t _{d(off)}	1.3	2.9	4.5	μs
	I _O =20A for U, V, W low to high		0.8	2.2	3.5	μs
Rise time	I _O =20A	t _f	-	0.3	-	μs

Thermal resistance

Chip to case Thermal Resistance	Junction-to-substrate (MOSFET)	θ _{jc}	-	4.5	-	°C/W
---------------------------------	--------------------------------	-----------------	---	-----	---	------

Protection Functions

Undervoltage Lockout Falling Threshold		V _{uv}	4.45	4.75	5.1	V
Undervoltage Lockout Hysteresis		V _{uv(hy)}	0.07	0.2	0.3	V
Undervoltage Lockout Output Delay		t _{uvoff}	-	1.0	-	μs
Over Current Threshold	Automatic Recovery	ISD	21	34	44	A
Over Current DIAG Output Delay Time		t _{ocdgoff}	-	4.3	-	μs
Over Current Shutdown Interval		t _{INT}	-	1	-	ms
Over Current Shutdown Output Delay		t _{ocoff}	-	4.3	-	μs
Ground Fault Short-Circuit Protection	Power-Cycle	IOC	47	84	113	A
Ground Fault Short-Circuit Detection DIAG Output Delay Time		t _{spdgoff}	-	3.0	-	μs
Ground Fault Short-Circuit Shutdown Output Delay Time		t _{spoff}	-	3.0	-	μs
Temperature Protection Shutdown Temperature Protection Recovery	IPM Substrate Temperature Rising Temperature Threshold	T _{st(rising)}	146	155	165	°C
	IPM Substrate Temperature Falling Temperature Threshold	T _{st(falling)}	126	135	145	°C
Over Temperature DIAG Output Delay Time		t _{tthdgoff}	-	3.4	-	μs
Over Temperature Shutdown Output Delay		t _{tthoff}	-	3.4	-	μs
Over Voltage Protection Rising Threshold		V _{ov}	24	-	-	V
Over Voltage Protection Hysteresis		V _{ov(hy)}	-	0.5	-	V
Over Voltage Protection Output Delay		t _{ovoff}	-	1.0	-	μs

DIAG Output

DIAG Output Voltage (DIAG1, DIAG2)	DIAGx=LOW, Sink Current =1mA	V _{DIAG}	-	-	0.2	V
DIAG Output Leakage Current (DIAG1, DIAG2)	V _{DIAG} =5V	I _{DILK}	-	-	1	μA

4. Product parametric performance is indicated in the Electrical Characteristics for the listed test conditions, unless otherwise noted. Product performance may not be indicated by the Electrical Characteristics if operated under different conditions.

STK984-090A-E

ELECTRICAL CHARACTERISTICS (Note 5)

at $8V \leq V_{B1}, V_{B2} \leq 18V$, $-40^{\circ}C \leq T_a \leq 125^{\circ}C$

Parameter	Test Conditions	Symbol	Min	Typ	Max	Unit
-----------	-----------------	--------	-----	-----	-----	------

Motor Control Input Terminal

HIGH level input voltage	Output ON. LINx, HINx to SG. x=U,V,W	Vin(on)	3.5	-	-	V
LOW level input voltage	Output OFF. LINx, HINx to SG. x=U,V,W	Vin(off)	-	-	1.5	V

Reset Input Terminal

Reset HIGH level input voltage	Output ON	Vreset(Hi)	3.5	-	-	V
Reset LOW level input voltage	Output OFF	Vreset(Lo)	-	-	1.5	V
Output Delay Time (ON)	From Reset Input Terminal (RESET=Hi) to Output ON	treset(on)	-	0.25	-	ms
Output Delay Time (OFF)	From Reset Input Terminal (RESET=Lo) to Output OFF	treset(off)	-	2	-	μ s

5. Product parametric performance is indicated in the Electrical Characteristics for the listed test conditions, unless otherwise noted. Product performance may not be indicated by the Electrical Characteristics if operated under different conditions.

STK984-090A-E

TYPICAL CHARACTERISTICS

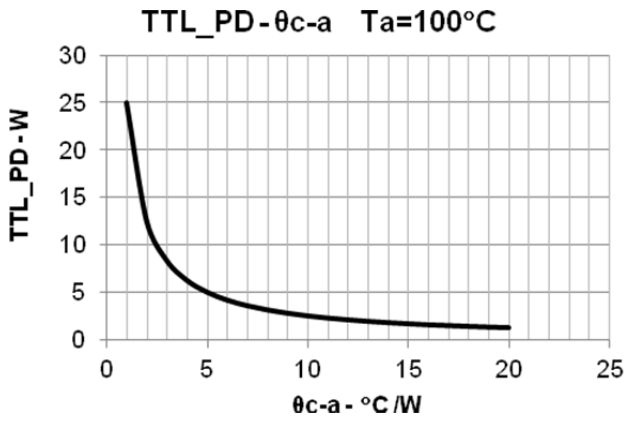

Figure 6 Power Dissipation versus Heatsink Size

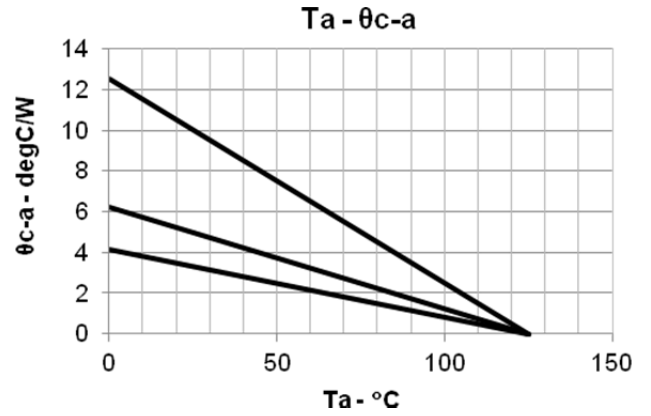

Figure 7 Heatsink size for PD=10W, 20W and 30W versus ambient temperature

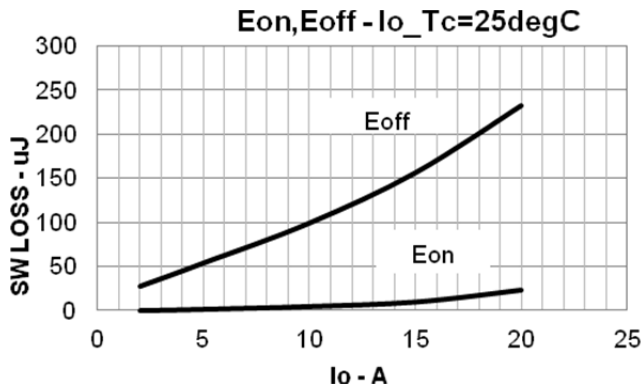

Figure 5 Switching losses versus current at 25°C

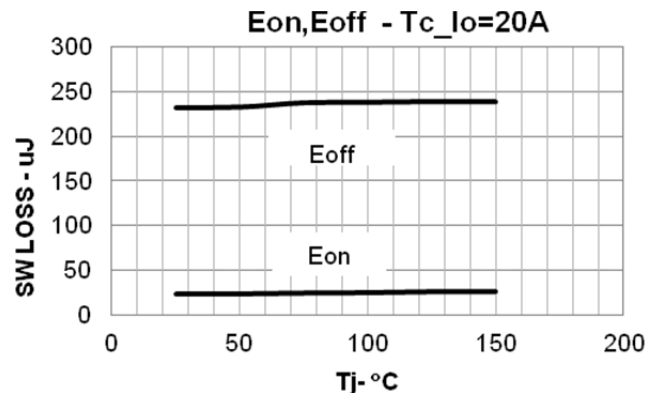

Figure 4 Switching losses versus temperature at 20A

APPLICATIONS INFORMATION

Functional Description

Table 2 shows the truth table for the normal operating mode. The truth table shows the U output which is controlled by the HINU and LINU inputs. The truth tables for the V and W outputs follow the same rules. The input signals are active HIGH. The RESET signal is active LOW.

An internal pull-down resistor (100kΩ typical) is connected to each input signal terminal. If an additional external pull-down resistor is used, it is important to ensure the input voltage threshold requirements are still met.

Input			Output			Operation Mode
HINU	LINU	RESET	U	DIAG1	DIAG2	
L	L	H	OFF	L	L	Output OFF
L	H	H	L	L	L	Lo Side ON
H	L	H	H	L	L	Hi Side ON
H	H	H	OFF	L	L	Output OFF
X	X	L	OFF	H	H	Output OFF

Table 2: Truth Table Normal Operating Mode

Operation in over-current and short-circuit conditions

Table 3 shows the truth table for over-current and short-circuit protection operating conditions for the U output which is controlled by the HINU and LINU inputs. The truth tables for the V and W outputs follow the same rules.

Over-current protection is activated only if LINU, LINV and LINW are in the high state. Short-circuit protection is activated only if LINU, LINV and LINW are in the low state.

Input			Output			Operation Mode
HINU	LINU	RESET	U	DIAG1	DIAG2	
L	L	H	OFF	L	L	Output OFF
L	H	H	L	H	L	Over Current Protection Operating
H	L	H	H	H	L	Short-Circuit Protection Operating
H	H	H	OFF	L	L	Output OFF
L/H	L/H	L	OFF	H	H	Output OFF

Table 3: Truth Table Over-current and Short-circuit Protection Modes

Operation in over-temperature conditions

Table 4 shows the truth table for over-temperature operating conditions.

Input			Output			Operation Mode
HINU	LINU	RESET	U	DIAG1	DIAG2	
X	X	H	OFF	L	H	Over Temperature Protection Operating
X	X	L	OFF	H	H	Output OFF

Table 4: Truth Table Over-temperature Protection

Operation in undervoltage conditions

Table 5 shows the truth table for low voltage protection operating conditions.

Input			Output			Operation Mode
HINU	LINU	RESET	U	DIAG1	DIAG2	
X	X	H	OFF	L	L	Low voltage Protection Operating
X	X	L	OFF	H	H	Output OFF

Table 5: Truth Table Low Voltage Protection

Operation in over-voltage conditions

Table 6 shows the truth table for over-voltage operating conditions.

Input			Output			Operation Mode
HINU	LINU	RESET	U	DIAG1	DIAG2	
X	X	H	OFF	L	L	Over Voltage Protection Operating
X	X	L	OFF	H	H	Output OFF

Table 6: Truth Table Over-Voltage Protection

DIAG Outputs

Terminal DIAG1 and DIAG2 are open drain outputs. A pull-up resistor of 4.7kΩ for a 5V power supply is recommended.

Layout

Voltage ringing due to stray inductance, especially in the power source wiring between VB1 and PG, will occur during switching. Use layout techniques such as short traces and wide traces to minimize the inductance of the power loop. Further, a high frequency capacitor needs to be placed very close to the terminals VB1 and PG, in addition to the electrolytic bulk capacitor.

System level fuse

A system level fuse in the VB1 power line is recommended to ensure a fail-safe design.

STK984-090A-E

Gate Driver Voltage: High-side and low-side

The high-side MOSFETs are driven with an internal charge pump. The gate voltage V_G from the built-in charge pump circuit is set at $V_G=V_{B1}+12V$.

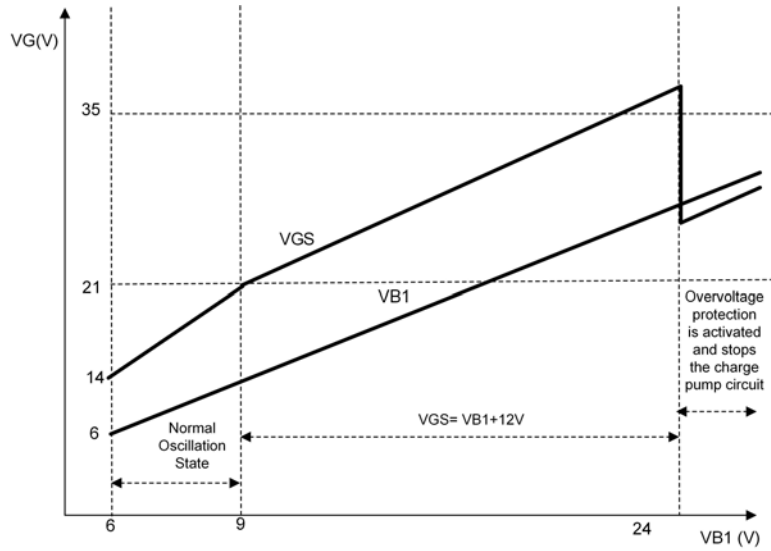

Figure 8: Gate drive voltage variation with battery voltage for high-side MOSFETs

The gate drive voltage for the low-side MOSFETs follows the voltage on V_{B1} . If V_{B1} exceeds 18.5V, the gate drive voltage is limited to 17V.

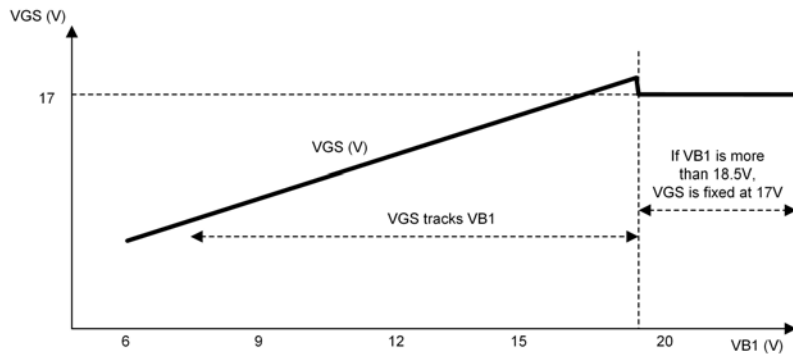

Figure 9: Gate drive voltage versus battery voltage for low-side MOSFETs

STK984-090A-E

RESET input

An internal pull-up resistor (100kΩ typical) is connected to the RESET signal. When the RESET pin is HIGH or left open, the IPM operates normally. If the RESET line is LOW, all six gate driver outputs will be set to the OFF state. When the short-circuit protection operates and latches the output OFF, the latched output OFF can be released by setting the RESET input LOW and then HIGH again.

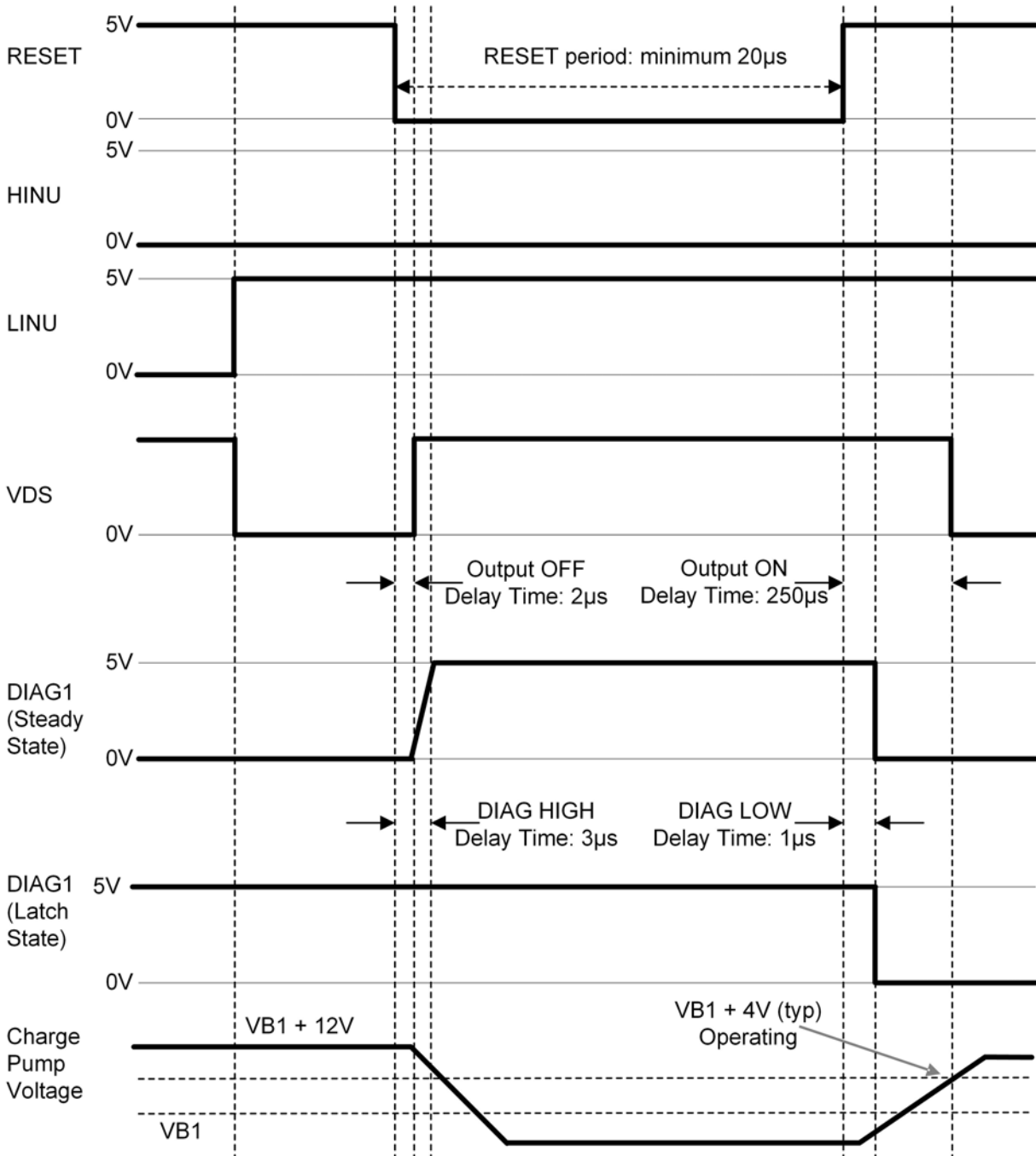

Figure 10: Timing diagram for RESET

STK984-090A-E

Short-circuit Protection Circuit

The Short-circuit Protection Circuit monitors the drain voltage of the high side MOSFET to detect short circuits. This circuit detects a short circuit when a short circuit current flows for longer than t_{spoff} (typically $3\mu s$). The outputs are switched to the OFF state and the DIAG1 signal is switched HIGH. The IPM is then latched in the short-circuit protection state. This state can be released by setting the RESET input LOW and then HIGH again.

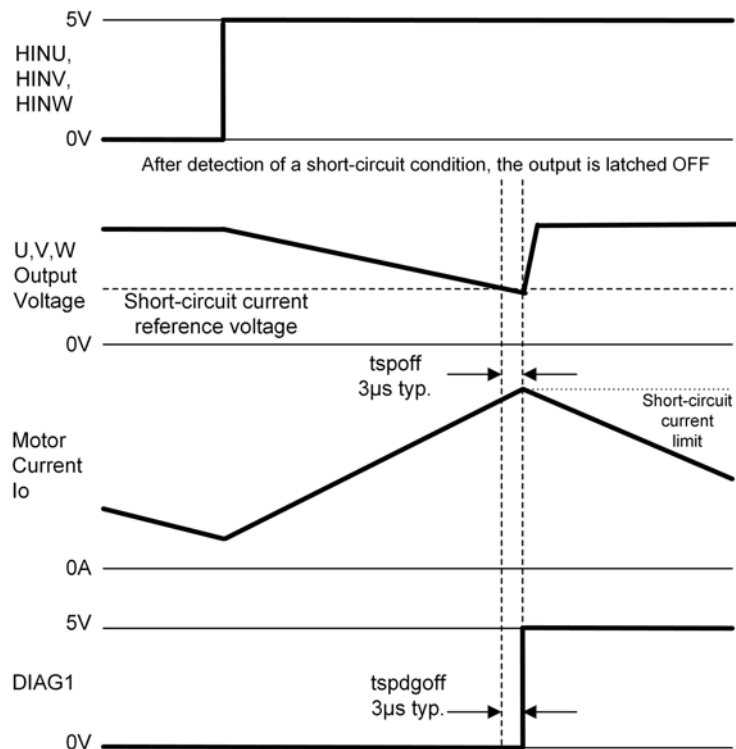

Figure 11: Timing Diagram Short-circuit Condition

Over-current Protection Circuit

The Over-current Protection Circuit monitors the drain voltage of the low-side MOSFETs to detect over currents. This circuit detects a short circuit when a short circuit current flows for longer than t_{ocoff} (typically $4.3\mu s$). When a short circuit is detected, the outputs are switched off and the short circuit condition is flagged by switching on DIAG1. The over-current protection state is held for time t_{INT} (typically 1ms) then released. It is not latched like the short-circuit current protection mode.

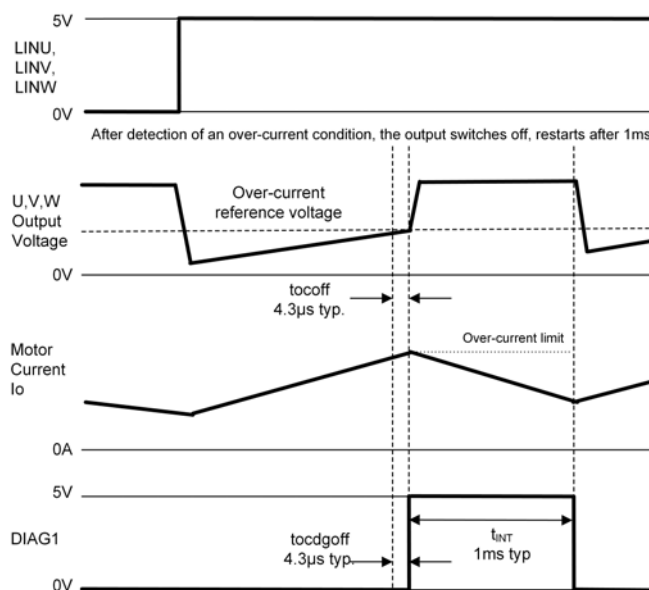

Figure 12: Timing Diagram for Over-current Protection

Undervoltage Lockout Protection Circuit

The Undervoltage Lockout Protection Circuit monitors voltages supplied to VB1 pin to detect low voltages. When the voltage on VB1 falls below the undervoltage lockout falling threshold, the outputs will be turned off. The undervoltage lockout circuit has a hysteresis. If the voltage on VB1 rises above the undervoltage lockout rising threshold, the module will return to normal operating mode.

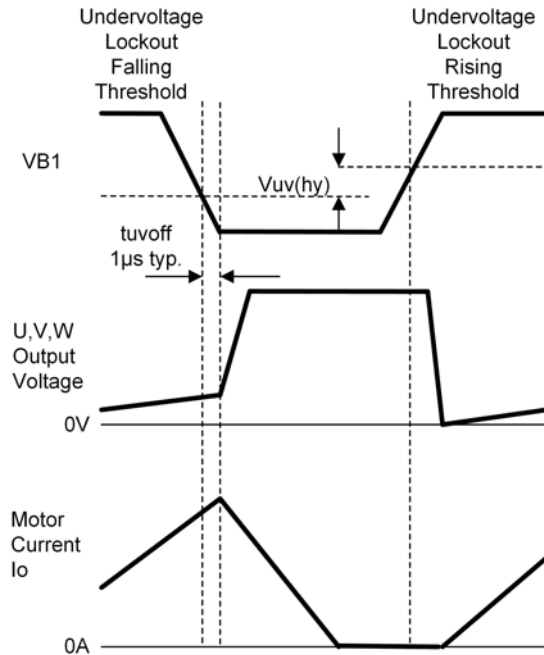

Figure 13: Timing Diagram Low Voltage Protection

Overvoltage Protection Circuit

The Overvoltage Protection Circuit monitors the voltage on VB1. If the voltage on VB1 exceeds the overvoltage protection threshold, the outputs will be switched off. The Overvoltage Protection Circuit has hysteresis. The IPM will return to normal operation when the voltage on VB1 falls below the over-voltage protection falling threshold voltage.

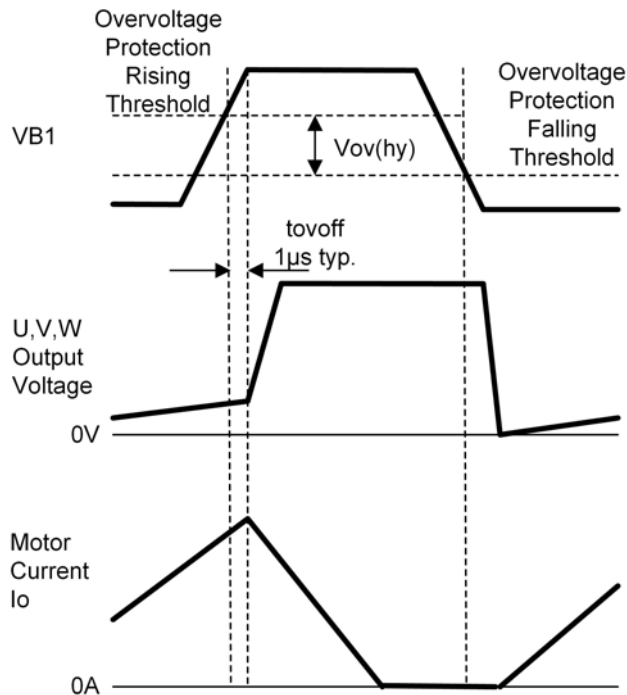

Figure 14 Timing Diagram Overvoltage Protection

STK984-090A-E

Over-temperature Protection Circuit

The Over-temperature Protection Circuit monitors the circuit substrate temperature to detect excessive temperatures. When the case temperature rises above the temperature shutdown rising threshold, the outputs are switched off and the over temperature condition is flagged on output DIAG2. There is hysteresis in the over-temperature protection circuit. When the case temperature falls below the temperature shutdown falling threshold, the circuit returns to normal operation and the over-temperature condition is no longer flagged on the DIAG2 output.

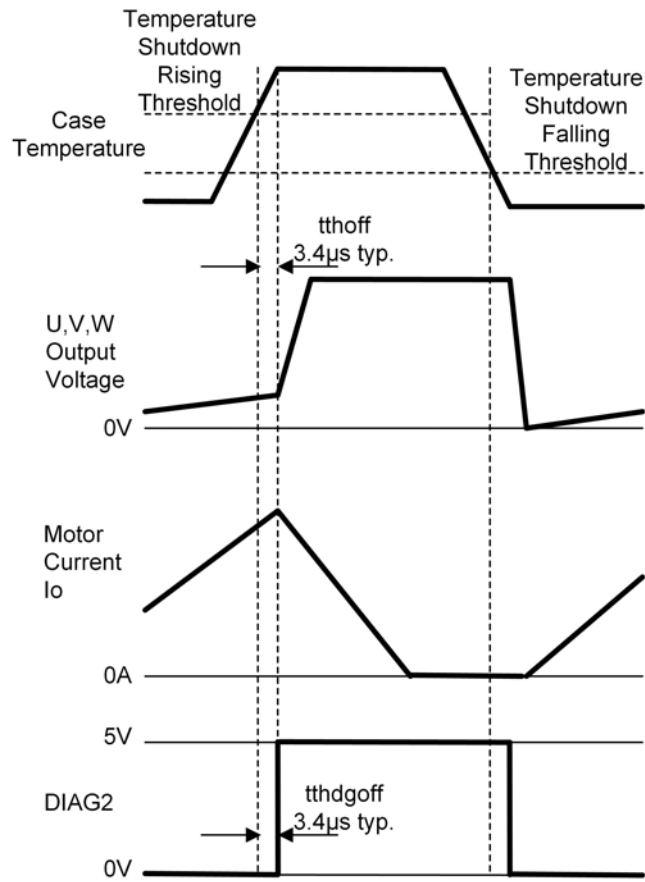
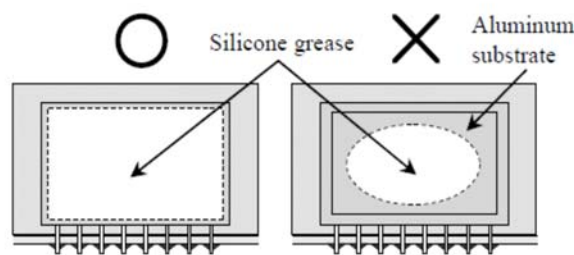
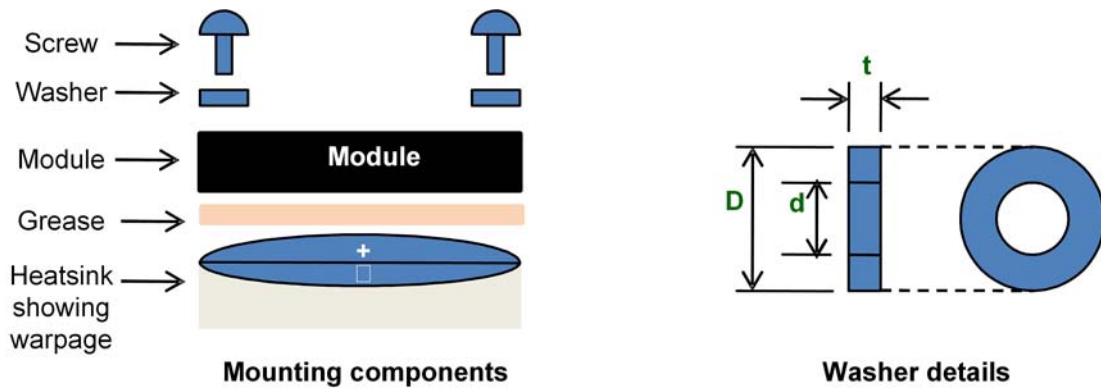

Figure 15: Timing Diagram Over-temperature Protection

STK984-090A-E

Mounting Instructions

Item	Recommended Conditions
Pitch	56.0 ± 0.2mm (Please refer to Package Outline Diagram)
Screw	Diameter : M3 Screw head types: pan head, truss head, binding head
Washer	Plane washer dimensions (Figure 16) D = 7mm, d = 3.2mm and t = 0.5mm JIS B 1256
Heat sink	Material: Aluminum or Copper Warpage (the surface that contacts IPM) : -50 to 100 μm Screw holes for the heat sink must be countersunk. No contamination on the heat sink surface that contacts IPM.
Torque	Temporary tightening : 20 to 30 % of final tightening on first screw Temporary tightening : 20 to 30 % of final tightening on second screw Final tightening : 0.6 to 0.9Nm on first screw Final tightening : 0.6 to 0.9Nm on second screw
Thermal Interface	Silicone grease is recommended. Thickness : 100 to 200 μm Uniformly apply silicon grease to whole back. Thermal foils are only recommended after careful evaluation. Thickness, stiffness and compressibility parameters have a strong influence on performance.



Thermal grease must be spread evenly (left is correct)

Figure 16: Module Mounting details: components; washer drawing; need for even spreading of thermal grease

STK984-090A-E

Reliability Specification

Ta=25°C±5°C, Relative humidity 65%±20% unless otherwise specified

Parameter		Test Conditions	Evaluation Time	Evaluation Method	Test Time
Mechanical Strength	Free-Fall	High = 75cm, drop on a woodblock Woodblock : maple 30×30×3cm Conform to JIS C 7021 A-8	Drop Time = 3 times	Electrical Characteristics	N = 5
	Vibration Fatigue	Vibration Frequently f = 10HZ to 55HZ Logarithmic Sweep Total Amplitude = 1.5+0.2mm	X, Y, Z Each direction 2hr	Electrical Characteristics Visual Inspection	N = 11
Environmental Test	Thermal Shock (Vapor Tank)	Ta = -40°C↔125°C (30min. each) Elapsed time after the test =2hr	1000 Cycles	Electrical Characteristics Visual Inspection Solder Junction	N = 11
	Pressure Cooker	Ta = 121°C, RH=100%, 2 air pressure	48hr	Electrical Characteristics	N = 11
Life Test	High-Temperature Storage	Ta = 125°C Elapsed time after the test = 3hr Conform to JIS C 7201 B-10	1000hr	Electrical Characteristics	N = 11
	Low-Temperature Storage	Ta = -40°C Elapsed time after the test=3hr Conform to JIS C 7021 B-12	1000hr	Electrical Characteristics	N = 11
	High Temperature High Humidity Bias	Ta = 85°C±2°C, RH = 85%±5% VB1, VB2 = 70% of Maximum Rating	1000hr	Electrical Characteristics	N = 11

Table 7: Reliability Specification

Test Circuits

■ VDS(sat) measurement (Pulse Measurement)

Pin No

Measured Phase	U	V	W	UN	VN	WN
M	21	21	21	13	15	17
N	13	15	17	19	19	19
m	4	5	6	7	8	9

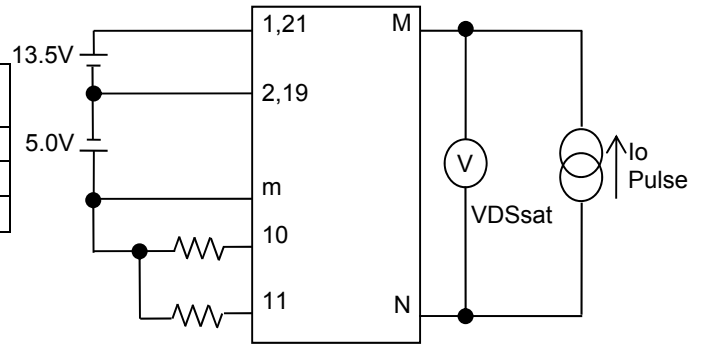

Figure 17 VDS Measurement Circuit

■ ICC Measurement

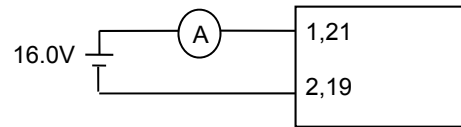

Figure 18 ICC Measurement Circuit

■ ISD Measurement

Pin No

Measured Phase	Short-Circuit Threshold			Overcurrent Threshold		
	U	V	W	UN	VN	WN
M	19	19	19	13	15	17
N	13	15	17	21	21	21
m	4	5	6	7	8	9

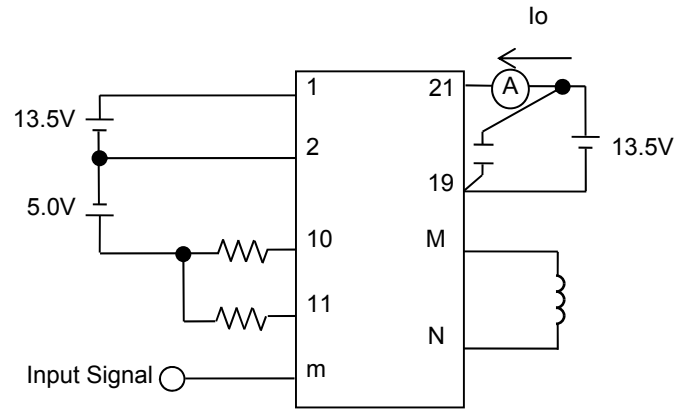

Figure 19 ISD Measurement Circuit

STK984-090A-E

■ Measurement of rise, fall and delay times

Pin No

Measured Phase	U	V	W	UN	VN	WN
M	19	19	19	13	15	17
N	13	15	17	21	21	21
m	4	5	6	7	8	9

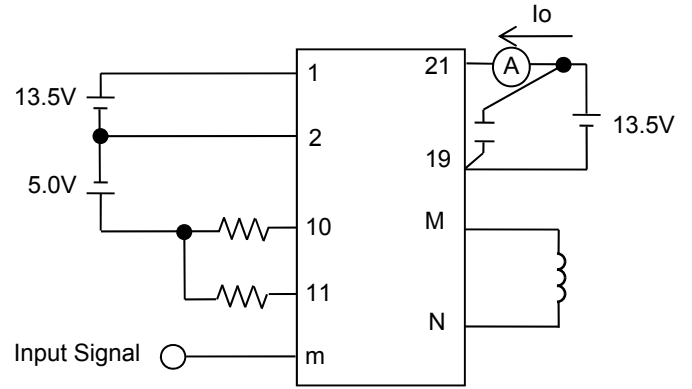

Figure 20 Switch Time Measurement Circuit

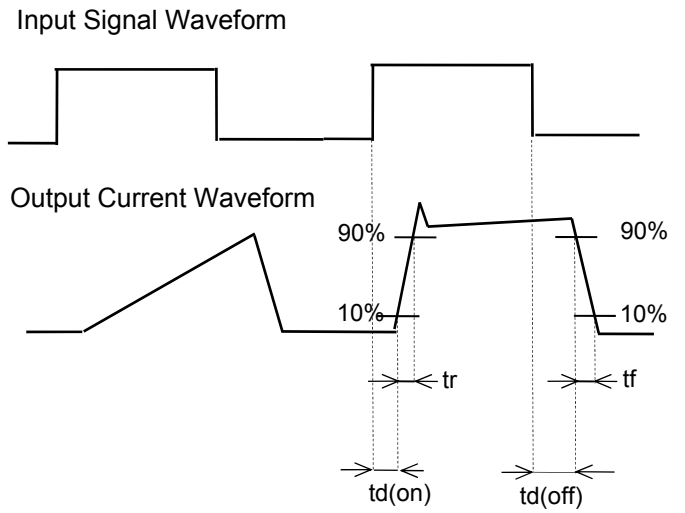
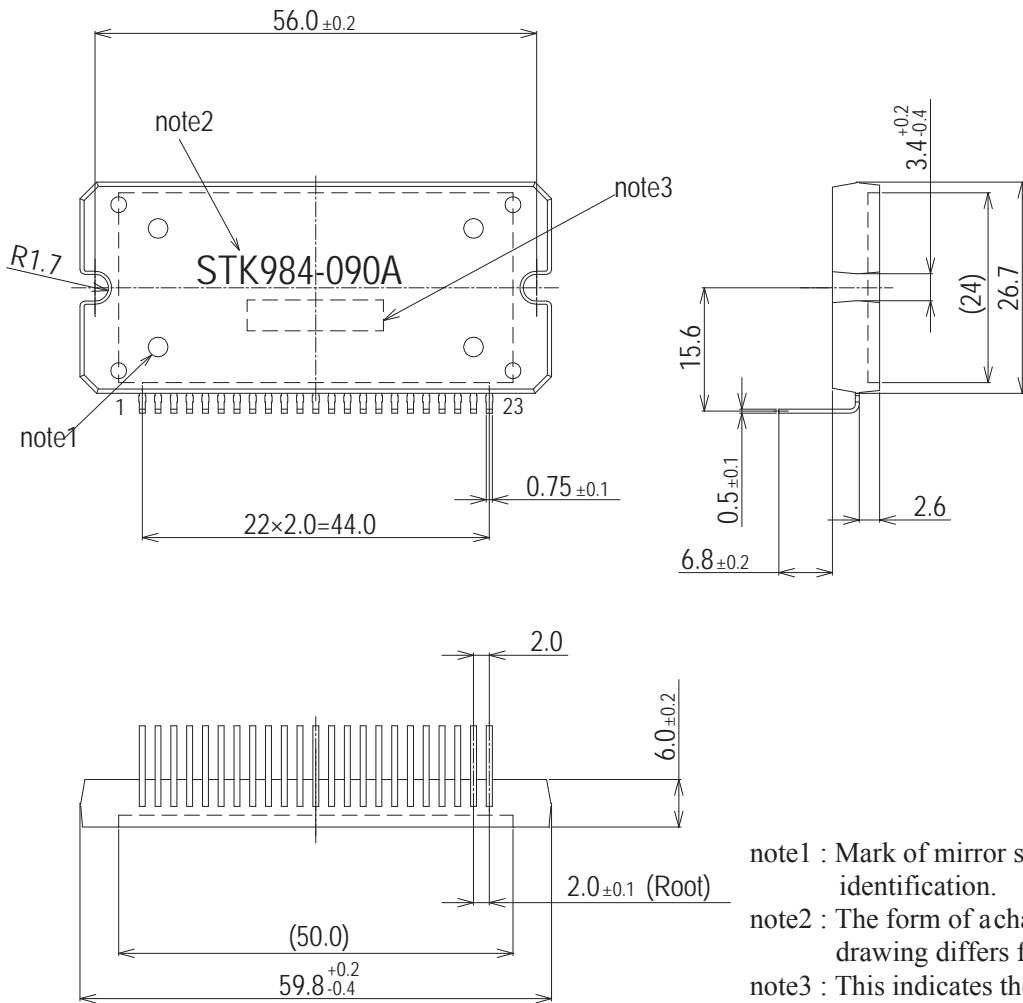

Figure 21 Switch Time Definitions

STK984-090A-E

PACKAGE DIMENSIONS

unit : mm



- note1 : Mark of mirror surface for No.1 pin identification.
- note2 : The form of a character in this drawing differs from that of IPM.
- note3 : This indicates the lot code.
The form of a character in this drawing differs from that of IPM.

ON Semiconductor and the ON logo are registered trademarks of Semiconductor Components Industries, LLC (SCILLC) or its subsidiaries in the United States and/or other countries. SCILLC owns the rights to a number of patents, trademarks, copyrights, trade secrets, and other intellectual property. A listing of SCILLC's product/patent coverage may be accessed at www.onsemi.com/site/pdf/Patent-Marking.pdf. SCILLC reserves the right to make changes without further notice to any products herein. SCILLC makes no warranty, representation or guarantee regarding the suitability of its products for any particular purpose, nor does SCILLC assume any liability arising out of the application or use of any product or circuit, and specifically disclaims any and all liability, including without limitation special, consequential or incidental damages. "Typical" parameters which may be provided in SCILLC data sheets and/or specifications can and do vary in different applications and actual performance may vary over time. All operating parameters, including "Typicals" must be validated for each customer application by customer's technical experts. SCILLC does not convey any license under its patent rights nor the rights of others. SCILLC products are not designed, intended, or authorized for use as components in systems intended for surgical implant into the body, or other applications intended to support or sustain life, or for any other application in which the failure of the SCILLC product could create a situation where personal injury or death may occur. Should Buyer purchase or use SCILLC products for any such unintended or unauthorized application, Buyer shall indemnify and hold SCILLC and its officers, employees, subsidiaries, affiliates, and distributors harmless against all claims, costs, damages, and expenses, and reasonable attorney fees arising out of, directly or indirectly, any claim of personal injury or death associated with such unintended or unauthorized use, even if such claim alleges that SCILLC was negligent regarding the design or manufacture of the part. SCILLC is an Equal Opportunity/Affirmative Action Employer. This literature is subject to all applicable copyright laws and is not for resale in any manner.

Mouser Electronics

Authorized Distributor

Click to View Pricing, Inventory, Delivery & Lifecycle Information:

[ON Semiconductor:](#)

[STK984-090A-E](#)