

NOTE

- 1. 端子テール部およびネイルの平坦度: 0.1mm MAX.
TAIL AND NAIL COPLANARITY TO BE 0.1mm MAX.
- 2. (極数/2) = 偶数 に適用
APPLY FOR (CIRCUIT SIZE/2) = EVEN.
- 3. 適用製品及び各種仕様書はSHEET 4を参照のこと
REFER TO SHEET 4 ABOUT APPLICABLE PRODUCTS AND VARIOUS SPECIFICATIONS.

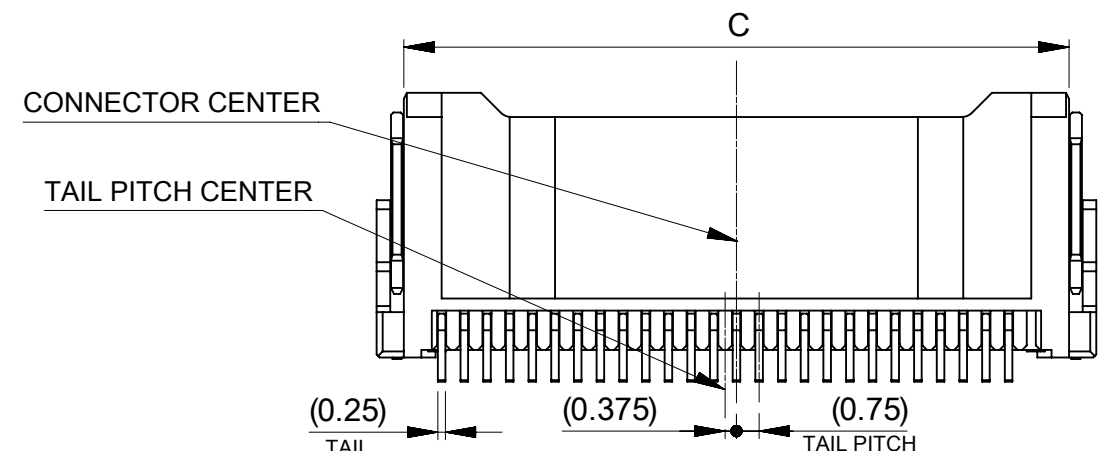
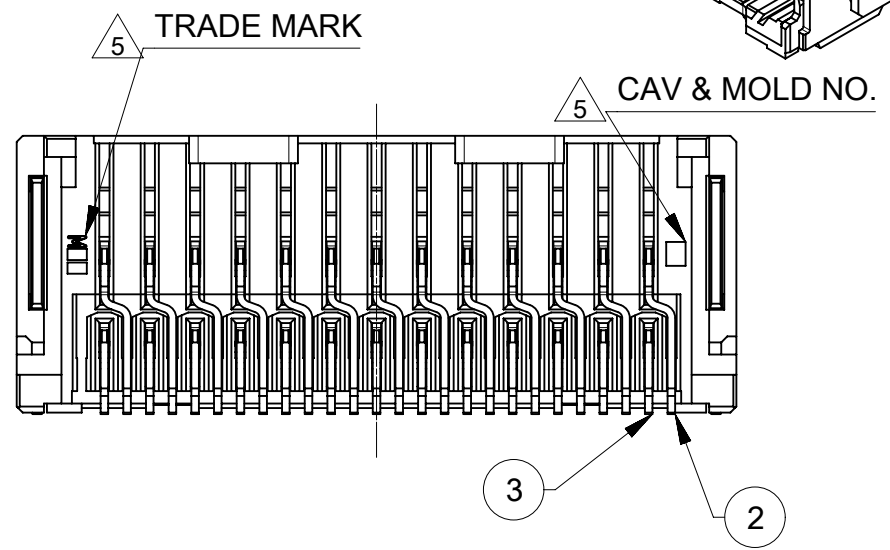
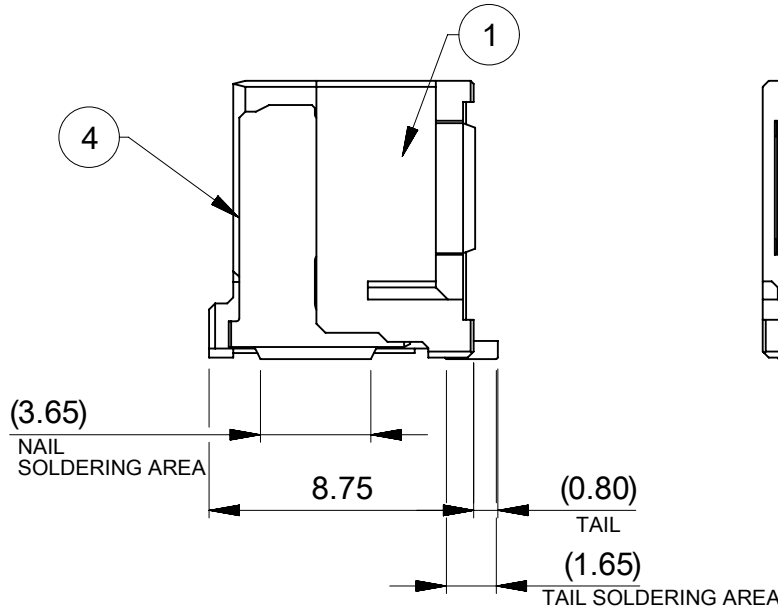
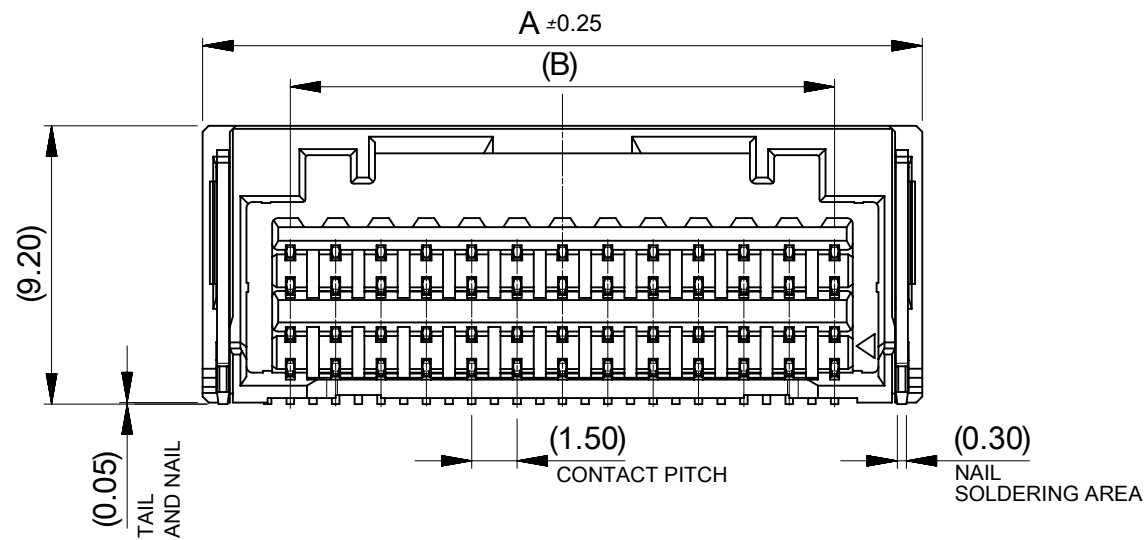
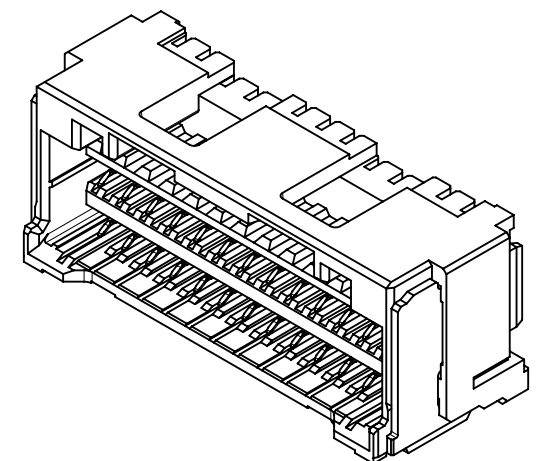

4. オーダー番号(製品番号): SHEET 6の製品一覧を参照のこと
ORDER No (PRODUCT No) : REFER TO SHEET 6 FOR PRODUCT LIST.

503148 * * 9 *

シリーズ番号 極数 色
SERIES NO CIRCUIT SIZE COLOR

CIRCUIT NO	COLOR
0	ナチュラル (ページユ) NATURAL (BEIGE)
1	黒 BLACK
2	赤 RED
4	青 BLUE
6	緑 GREEN

22.0	±0.25	18.0	23.8	26
20.5		16.5	22.3	24
19.0		15.0	20.8	22
17.5		13.5	19.3	20
16.0		12.0	17.8	18
14.5		10.5	16.3	16
13.0		9.0	14.8	14
11.5		7.5	13.3	12
10.0		6.0	11.8	10
8.5		(±0.2)	4.5	10.3
C		B	A	極数 CIRCUIT NO

番号 NO.	部品 PART	材質 MATERIAL
①	ハウジング HOUSING	ポリアミド(PA) UL94V-0 色 : SEE CHART POLYAMIDE(PA) UL94V-0 COLOR : SEE CHART
②、③	ターミナル A, B TERMINAL A, B	銅合金 COPPER ALLOY
		錫めっき : 1.0 micro-meter MIN MATTE TIN PLATING(TAIL AREA) ニッケルめっき(下地) : 1.0 micro-meter MIN NICKEL (UNDER PLATING)
④	ネイル NAIL	黄銅 BRASS 錫めっき : 1.0 micro-meter MIN MATTE TIN PLATING ニッケルめっき(下地) : 1.0 micro-meter MIN NICKEL (UNDER PLATING)

5. トレードマーク : Mプラス 2文字の製造工場を示す
アルファベットにて表示。
但し、"J"はJAPANを、"L"はMALAYSIAを示す。
(例 : MXJ, MXL)
金型番号 : アルファベット2文字にて表示。
(例 : 1A, 12A, 1B, 12B)

THIS DRAWING CONTAINS INFORMATION THAT IS PROPRIETARY TO MOLEX ELECTRONIC TECHNOLOGIES, LLC AND SHOULD NOT BE USED WITHOUT WRITTEN PERMISSION

DIMENSION UNITS	SCALE	CURRENT REV DESC:					
mm	NTS						
GENERAL TOLERANCES (UNLESS SPECIFIED)					EC NO: 634759		
ANGULAR TOL	± 3.0 °				DRWN: MIKEDA01 2020/03/26		
4 PLACES	± 0.2				CHK'D: SAKIYAMA 2020/03/27		
3 PLACES	± 0.2				APPR: KOMURAKAMI 2020/03/30		
2 PLACES	± 0.2	INITIAL REVISION:					
1 PLACE	± 0.25	DRWN: MIKEDA01 2019/05/07					
0 PLACES	± 0.3	APPR: KOMURAKAMI 2020/03/03					
DRAFT WHERE APPLICABLE MUST REMAIN WITHIN DIMENSIONS		THIRD ANGLE PROJECTION	DRAWING	SERIES			
			A3-SIZE	503148			
		MATERIAL NUMBER	CUSTOMER	SHEET NUMBER			
		503148****	GENERAL	1 OF 6			

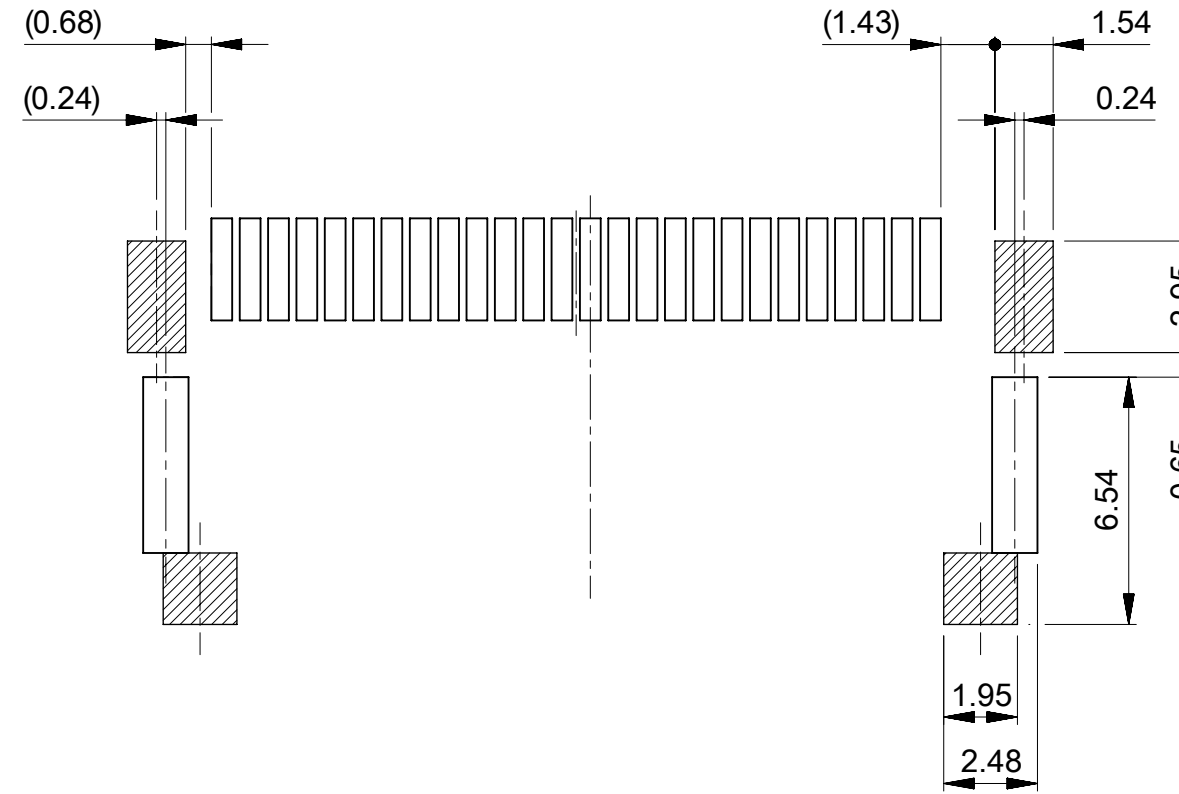
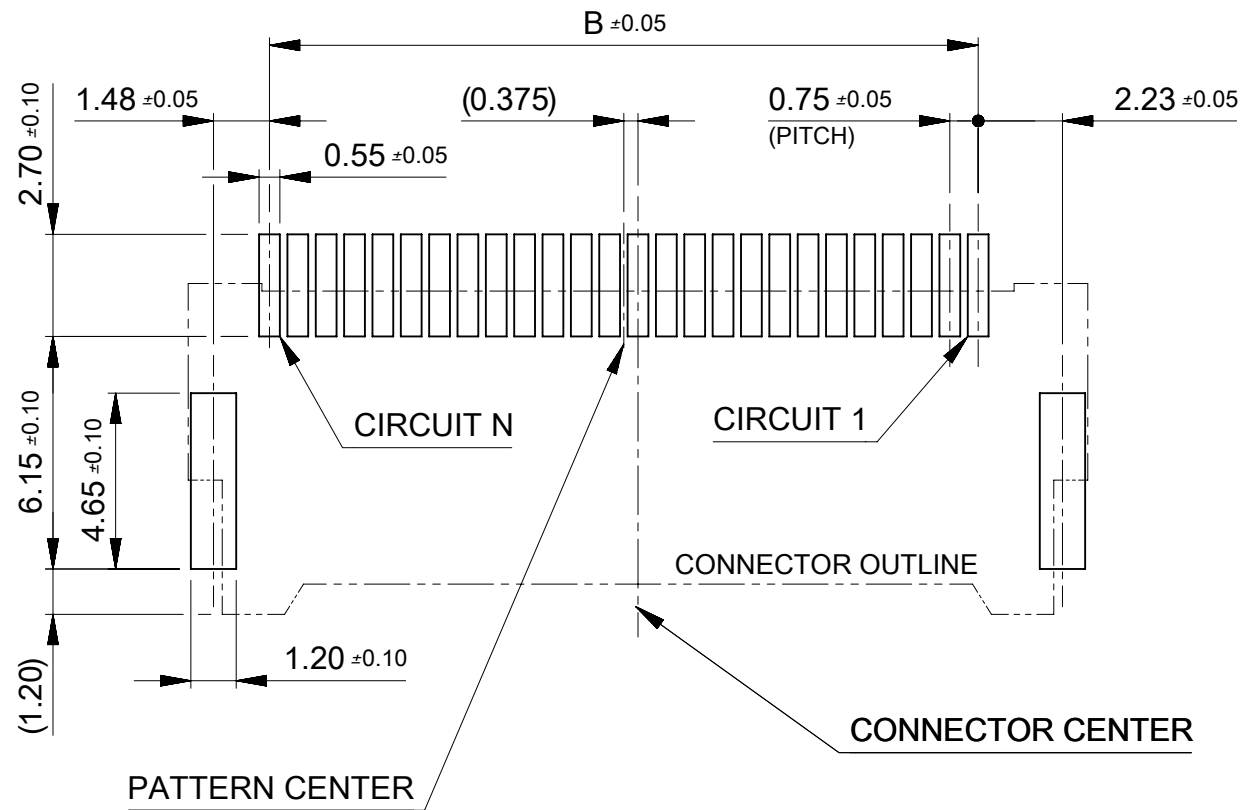

基板パターンレイアウト(参考)
RECCOMENDED PCB PATTERN LAYOUT (REF.)

(参考: メタルマスク厚さ 0.10mm, マスク開口率100%)
(REFERENCE: METAL MASK THICKNESS 0.10MM, APERTURE RATIO 100%)

NOTE

- △ コネクタ下にパターン及びスルーホールを設置する場合、基板面からパターン盛り上がりは0.1mm MAX.とすること
ただし、図示したパターン禁止エリアを除く
THE CONVEX ON THE PCB TO BE 0.1mm MAX. WHEN SET SOME PATTERNS OR THROUGH HOLES UNDER THE CONNECTOR.
EXCEPT INDICATED AREA.

△ パターン非推奨エリア

パターンを引き回す際は、製品機能に影響がないことをご確認ください。
PATTERN IS NOT RECCOMENDED ON THE HATCHED AREA.
PLEASE CHECK NOT TO HAVE PROBLEM FOR PRODUCT FUNCTION
WHEN SETTING PATTERN ON THE HATCHED AREA.

THIS DRAWING CONTAINS INFORMATION THAT IS PROPRIETARY TO MOLEX ELECTRONIC TECHNOLOGIES, LLC AND SHOULD NOT BE USED WITHOUT WRITTEN PERMISSION									
DIMENSION UNITS		SCALE		CURRENT REV DESC:				molex	
mm		NTS							
GENERAL TOLERANCES (UNLESS SPECIFIED)				EC NO: 634759				CLIK-MATE 1.5	
ANGULAR TOL ± 3.0 °				DRWN: MIKEDA01 2020/03/26				DUAL ROW SMT R/A TYPE REC ASSY TIN PLATING	
4 PLACES ± 0.2				CHK'D: SAKIYAMA 2020/03/27					
3 PLACES ± 0.2				APPR: KOMURAKAMI 2020/03/30				PRODUCT CUSTOMER DRAWING	
2 PLACES ± 0.2				INITIAL REVISION:				DOCUMENT NUMBER	
1 PLACE ± 0.25				DRWN: MIKEDA01 2019/05/07				5031480000-SD	
0 PLACES ± 0.3				APPR: KOMURAKAMI 2020/03/03				PSD 000 B	
DRAFT WHERE APPLICABLE MUST REMAIN WITHIN DIMENSIONS		THIRD ANGLE PROJECTION		DRAWING		SERIES		MATERIAL NUMBER	
				A3-SIZE		503148		503148****	
CUSTOMER		GENERAL		SHEET NUMBER		2 OF 6			

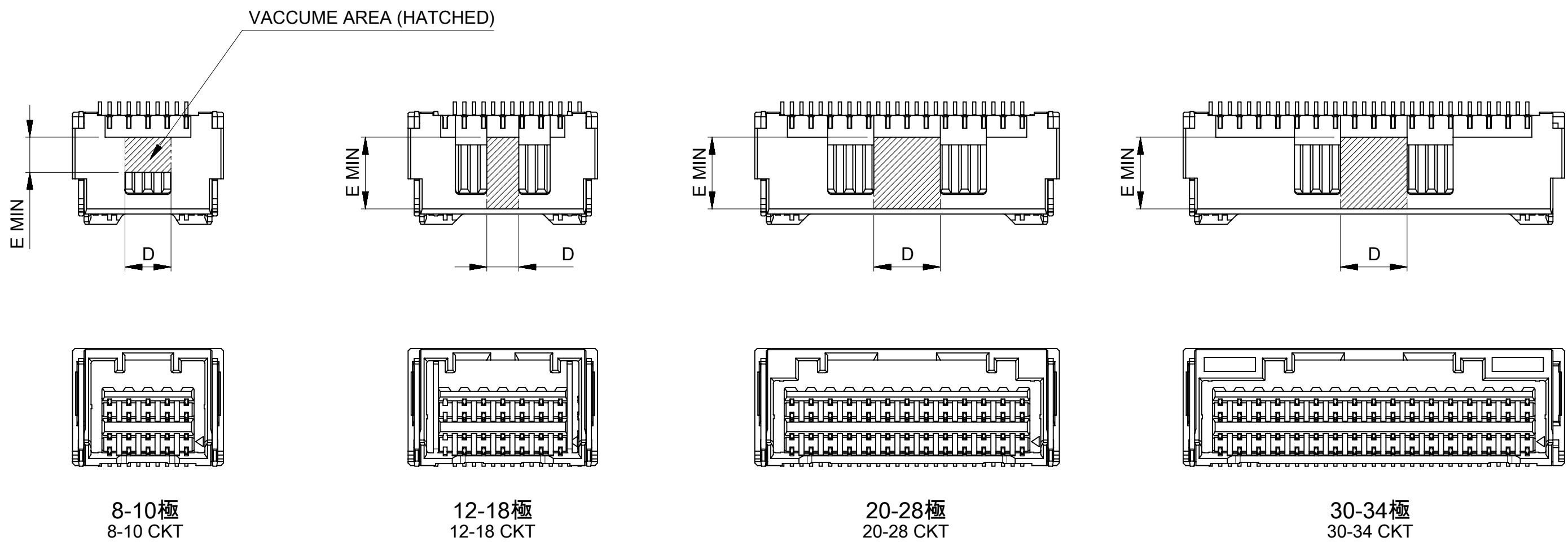

極数別ハウジング形状および吸着エリア
HOUSING SHAPE AND VACCUME AREA AT EACH CKTS

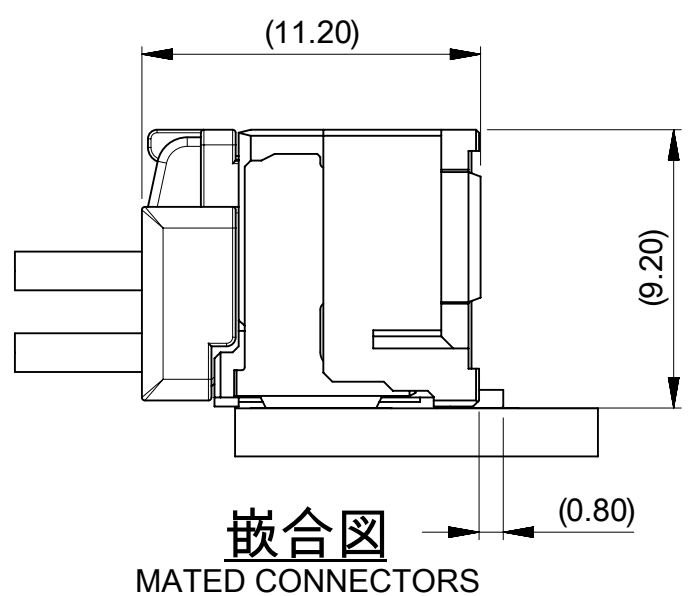

5.6	5.2	26
		24
	3.2	22
		20
2.5	16	
	14	
2.3	12	
	10	
2.75	3.6	8
	E	D

THIS DRAWING CONTAINS INFORMATION THAT IS PROPRIETARY TO MOLEX ELECTRONIC TECHNOLOGIES, LLC AND SHOULD NOT BE USED WITHOUT WRITTEN PERMISSION

DIMENSION UNITS	SCALE	CURRENT REV DESC:		
mm	NTS			
GENERAL TOLERANCES (UNLESS SPECIFIED)		molex		
ANGULAR TOL	± 3.0 °	CLIK-MATE 1.5		
4 PLACES	± 0.2	DUAL ROW SMT R/A TYPE REC ASSY TIN PLATING		
3 PLACES	± 0.2	PRODUCT CUSTOMER DRAWING		
2 PLACES	± 0.2	DOCUMENT NUMBER		
1 PLACE	± 0.25	5031480000-SD		
0 PLACES	± 0.3	DOC TYPE DOC PART REVISION		
DRAFT WHERE APPLICABLE MUST REMAIN WITHIN DIMENSIONS		PSD 000 B		
THIRD ANGLE PROJECTION		DRAWING	SERIES	MATERIAL NUMBER
		A3-SIZE	503148	503148****
		CUSTOMER	SHEET NUMBER	
		GENERAL	3 OF 6	

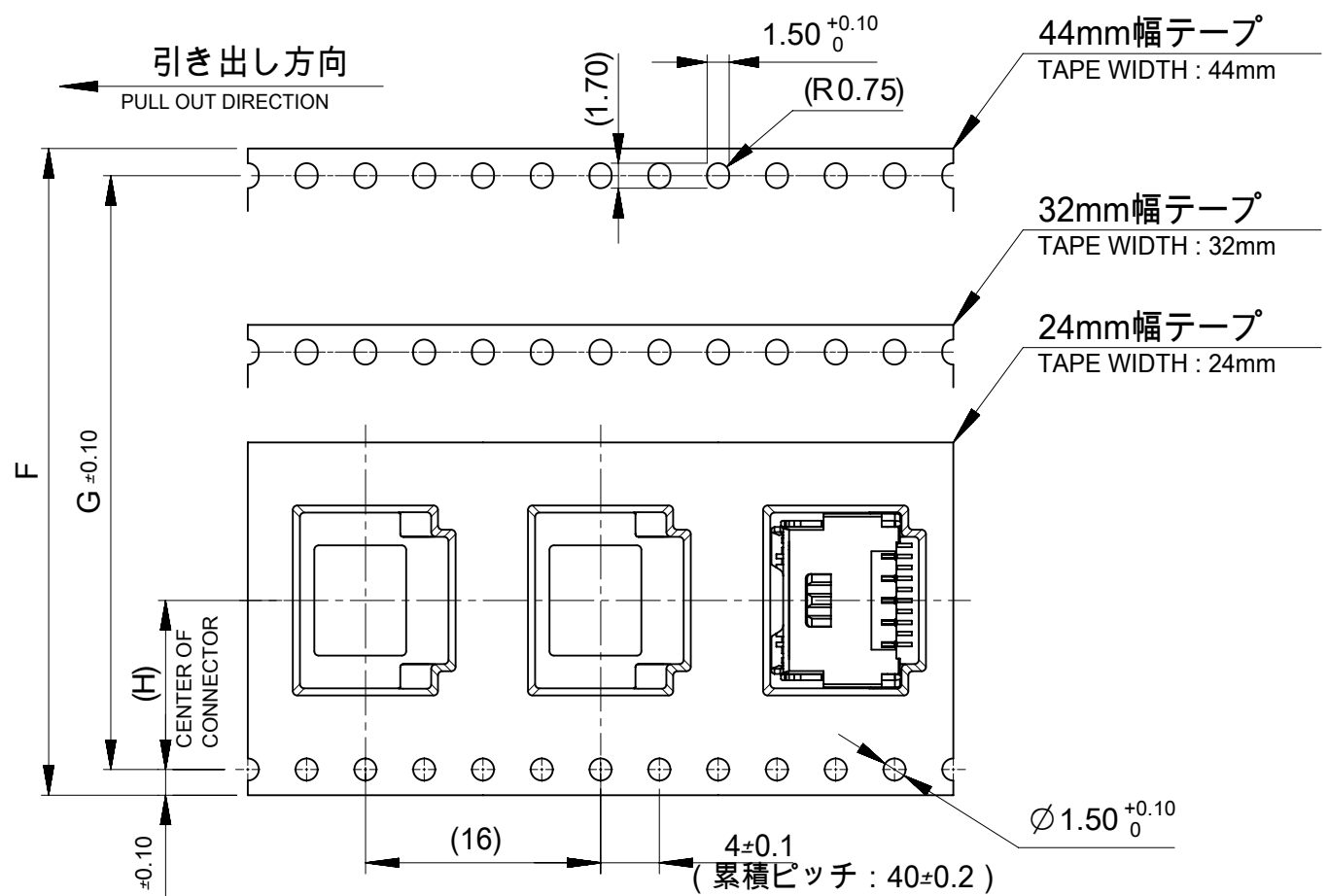
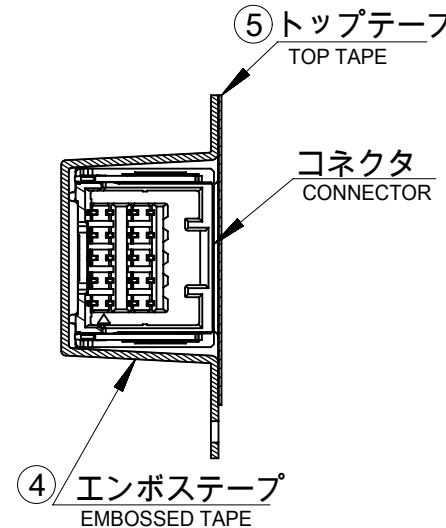
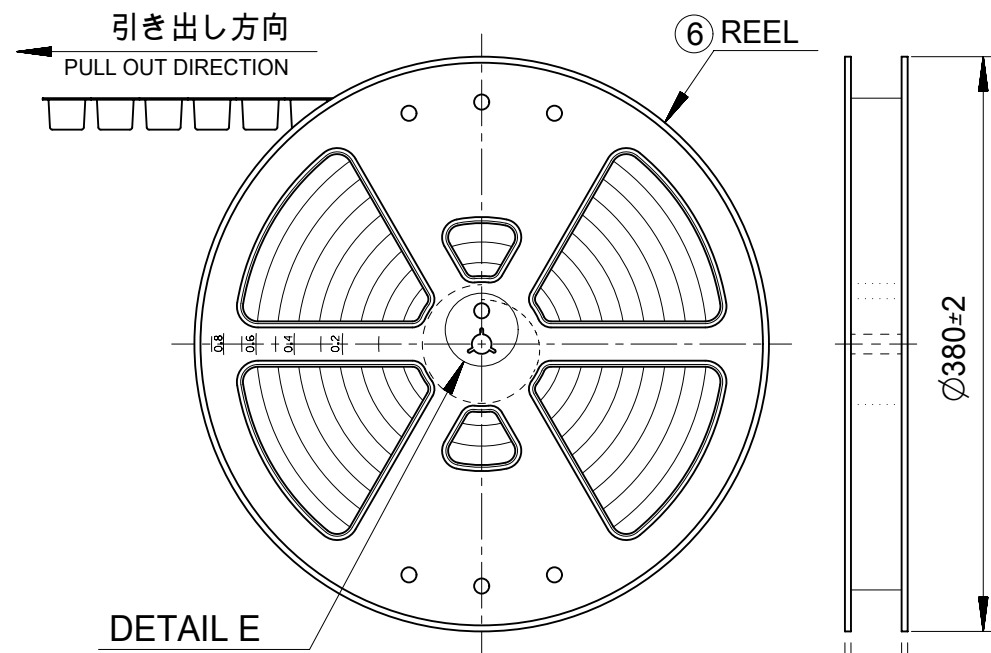

NOTE

- 7. 梱包数量 : 550個 / リール
NUMBER OF CONNECTORS : 550 PIECES/REEL
- 8. リードテープ長さ
LEAD TAPE LENGTH

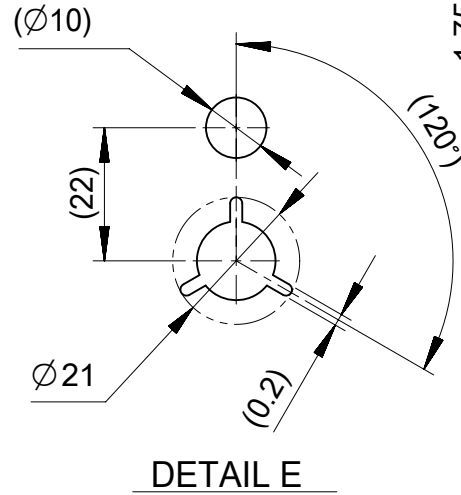
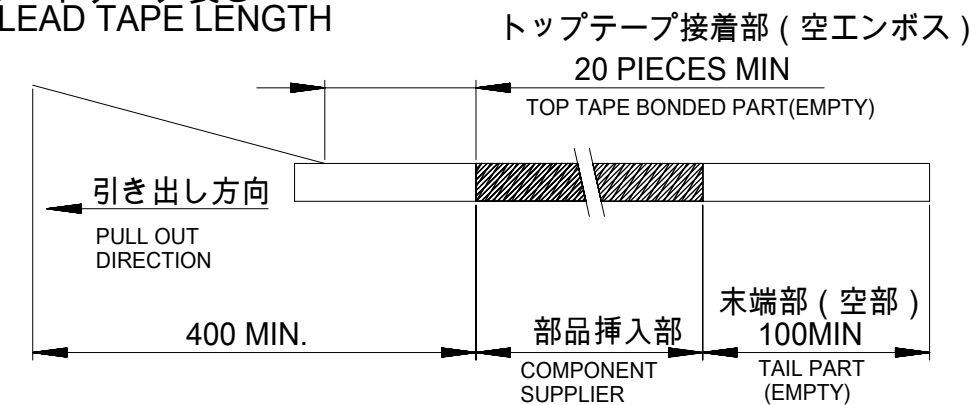

- 9. トップテープの剥離強度: 0.1 ~ 0.3N (10.2 ~ 132.5gf)
剥離方向は下記参照:
PEELING OFF FORCE OF TOP TAPE
PEELING DIRECTION AS SHOWN IN FOLLOWING FIGURE:
尚、本規格は出荷時に適用。(ただし輸送時に剥離が発生しないこと)
THIS REQUIREMENT SHOULD BE APPLIED AT SHIPMENT.
PEELING OFF SHOULD NOT BE ALLOWED DURING TRANSPORTING.

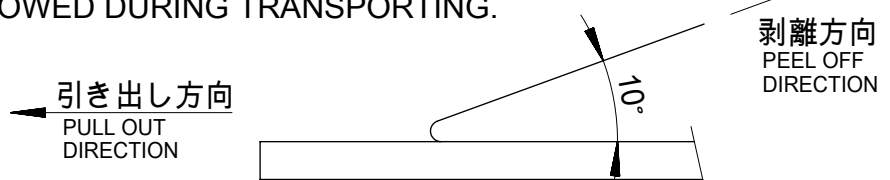

49.4	45.4	20.2	40.4	44±0.3	26
					24
					22
					20
					18
37.4	33.4	14.2	28.4	32±0.3	16
					14
					12
29.4	25.4	11.5	-	24 ^{+0.3} _{-0.1}	10
					8
K	J	H	G	エンボステープ幅F WIDTH OF TAPE	極数 CIRCUIT NO

番号 No.	部品 PART	材質 MATERIAL
④	エンボステープ EMBOSSED TAPE	ポリスチレン(PS) POLYSTYLENE
⑤	トップテープ TOP TAPE	ポリエチレン、ポリエチレンテレフタレート POLYETHYLENE (PE), POLYETHYLENE TELEPHTHALATE (PET)
⑥	リール REEL	ポリスチレン (リサイクル材を含む) POLYSTYLENE (CONTAINED RECYCLED MATERIAL)

THIS DRAWING CONTAINS INFORMATION THAT IS PROPRIETARY TO MOLEX ELECTRONIC TECHNOLOGIES, LLC AND SHOULD NOT BE USED WITHOUT WRITTEN PERMISSION

DIMENSION UNITS mm	SCALE NTS	CURRENT REV DESC:		molex		
GENERAL TOLERANCES (UNLESS SPECIFIED)		EC NO: 634759				
ANGULAR TOL	± 3.0°	DRWN: MIKEDA01	2020/03/26	DUAL ROW SMT R/A TYPE REC ASSY TIN PLATING		
4 PLACES	± 0.2	CHK'D: SAKIYAMA	2020/03/27	PRODUCT CUSTOMER DRAWING		
3 PLACES	± 0.2	APPR: KOMURAKAMI	2020/03/30	DOCUMENT NUMBER		
2 PLACES	± 0.2	INITIAL REVISION:		5031480000-SD		
1 PLACE	± 0.25	DRWN: MIKEDA01		2019/05/07	DOC TYPE	DOC PART
0 PLACES	± 0.3	APPR: KOMURAKAMI		2020/03/03	000	B
DRAFT WHERE APPLICABLE MUST REMAIN WITHIN DIMENSIONS		THIRD ANGLE PROJECTION	DRAWING	SERIES	MATERIAL NUMBER	CUSTOMER
			A3-SIZE	503148	503148****	GENERAL
						SHEET NUMBER
						4 OF 6

△₃ 適用製品及び各種仕様書
 APPLICABLE PRODUCTS AND VARIOUS SPECIFICATIONS

梱包仕様書 PACKAGING SPECIFICATION	PART NUMBER 503148**9*	DOCUMENT NUMBER SPK-503148-001
----------------------------------	---------------------------	-----------------------------------

適用嵌合相手 MATE WITH	HOUSING	TERMINAL	
		#24-28	#26-30
シリーズ番号 SERIES NUMBER	503149	502579	503429
製品仕様書 PRODUCT SPECIFICATION	5031490000-PS/PS/000		
アプリケーション仕様書 APPLICATION SPECIFICATION	AS-503149-001		

THIS DRAWING CONTAINS INFORMATION THAT IS PROPRIETARY TO MOLEX ELECTRONIC TECHNOLOGIES, LLC AND SHOULD NOT BE USED WITHOUT WRITTEN PERMISSION										
DIMENSION UNITS	SCALE	CURRENT REV DESC:				molex				
mm	NTS					CLIK-MATE 1.5 DUAL ROW SMT R/A TYPE REC ASSY TIN PLATING				
GENERAL TOLERANCES (UNLESS SPECIFIED)		EC NO: 634759				DOCUMENT NUMBER				
ANGULAR TOL ± 3.0 °		DRWN: MIKEDA01 2020/03/26				5031480000-SD				
4 PLACES ± 0.2		CHK'D: SAKIYAMA 2020/03/27				DOC TYPE				
3 PLACES ± 0.2		APPR: KOMURAKAMI 2020/03/30				PSD				
2 PLACES ± 0.2		INITIAL REVISION:				DOC PART				
1 PLACE ± 0.25		DRWN: MIKEDA01 2019/05/07				000				
0 PLACES ± 0.3		APPR: KOMURAKAMI 2020/03/03				REVISION				
DRAFT WHERE APPLICABLE MUST REMAIN WITHIN DIMENSIONS		THIRD ANGLE PROJECTION	DRAWING	SERIES	MATERIAL NUMBER	CUSTOMER	SHEET NUMBER			
			A3-SIZE	503148	503148****	GENERAL	5 OF 6			

4 製品一覧
PRODUCTS LIST

緑 GREEN	青 BLUE	赤 RED	黒 BLACK	ナチュラル(ベージュ) NATURAL(BEIGE)	HOUSING COLOR
503148 2696	503148 2694	503148 2692	503148 2691	503148 2690	26
503148 2496	503148 2494	503148 2492	503148 2491	503148 2490	24
503148 2296	503148 2294	503148 2292	503148 2291	503148 2290	22
503148 2096	503148 2094	503148 2092	503148 2091	503148 2090	20
503148 1896	503148 1894	503148 1892	503148 1891	503148 1890	18
503148 1696	503148 1694	503148 1692	503148 1691	503148 1690	16
503148 1496	503148 1494	503148 1492	503148 1491	503148 1490	14
503148 1296	503148 1294	503148 1292	503148 1291	503148 1290	12
503148 1096	503148 1094	503148 1092	503148 1091	503148 1090	10
503148 0896	503148 0894	503148 0892	503148 0891	503148 0890	8
オーダー番号 ORDER NO					極数 CIRCUIT NO

THIS DRAWING CONTAINS INFORMATION THAT IS PROPRIETARY TO MOLEX ELECTRONIC TECHNOLOGIES, LLC AND SHOULD NOT BE USED WITHOUT WRITTEN PERMISSION									
DIMENSION UNITS	SCALE	CURRENT REV DESC:					molex		
mm	NTS						CLIK-MATE 1.5		
GENERAL TOLERANCES (UNLESS SPECIFIED)		EC NO: 634759					DUAL ROW SMT R/A TYPE REC ASSY TIN PLATING		
ANGULAR TOL	± 3.0 °	DRWN: MIKEDA01 2020/03/26							
4 PLACES	± 0.2	CHK'D: SAKIYAMA 2020/03/27							
3 PLACES	± 0.2	APPR: KOMURAKAMI 2020/03/30					PRODUCT CUSTOMER DRAWING		
2 PLACES	± 0.2	INITIAL REVISION:					DOCUMENT NUMBER		
1 PLACE	± 0.25	DRWN: MIKEDA01 2019/05/07					5031480000-SD		
0 PLACES	± 0.3	APPR: KOMURAKAMI 2020/03/03					DOC TYPE	DOC PART	REVISION
DRAFT WHERE APPLICABLE MUST REMAIN WITHIN DIMENSIONS		THIRD ANGLE PROJECTION	DRAWING	SERIES	MATERIAL NUMBER	CUSTOMER		SHEET NUMBER	
			A3-SIZE	503148	503148****	GENERAL		6 OF 6	