

NO.

CODE

C/M

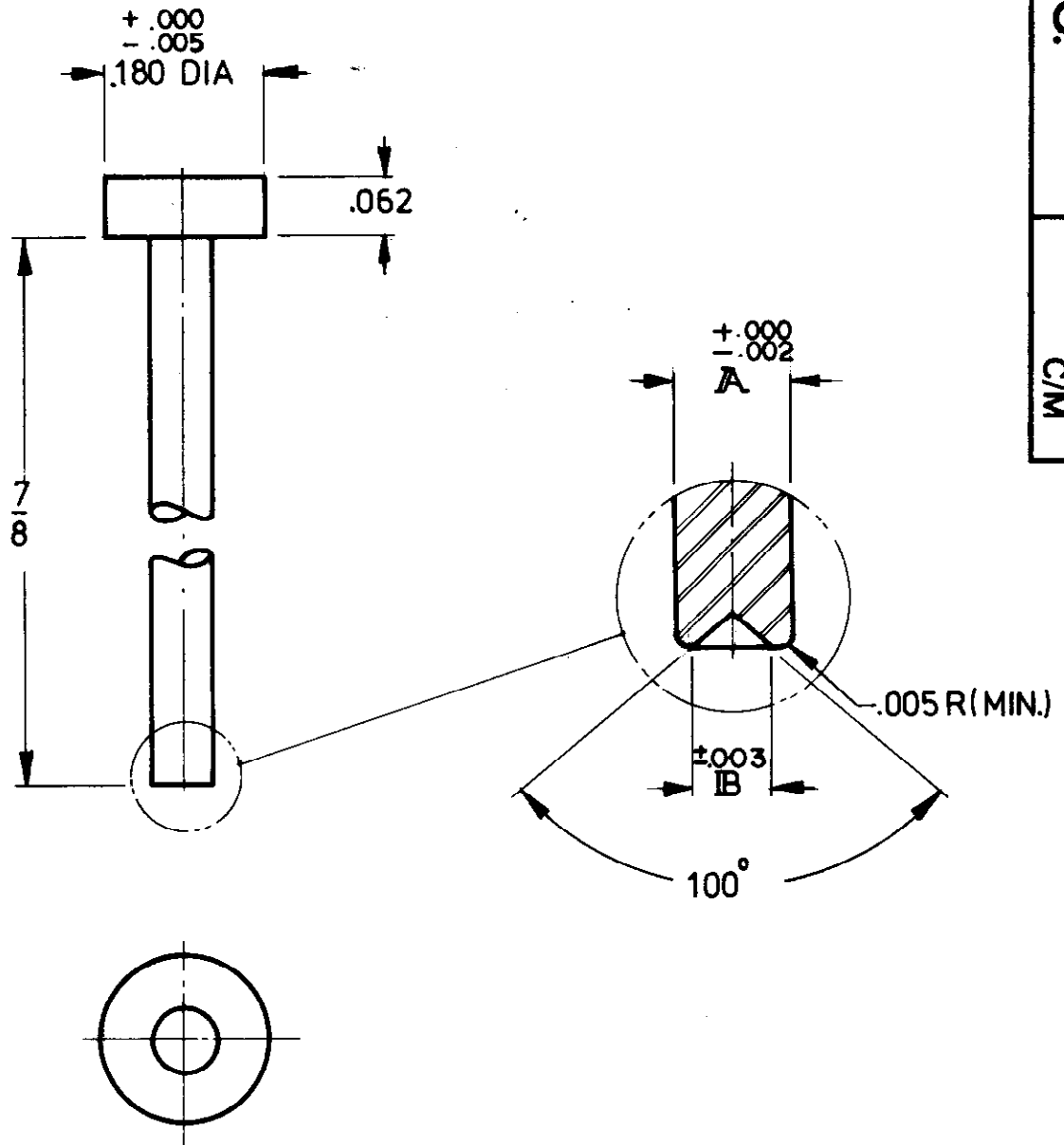

NOTE:

HEAT TREAT TO ROCK C 52-56
 BLACK OXIDE
 BREAK ALL SHARP EDGES

P/No.	A	IB
1315	.045	.038
1316	.069	.055

KEYSTONE ELECTRONICS CORP.

ASTORIA, N.Y. 11106-2017

PART NAME RECEDING PIN

MATERIAL SAE (W1) DRILL ROD

FINISH
AS NOTED

DRAWN BY LN **DATE** 8 12 83

APPROVED AA **SCALE** _____

TOLERANCES
 FRACTIONAL $\pm .015$
 DECIMAL $\pm .005$ ANGULAR \pm
 UNLESS OTHERWISE NOTED

DWG. NO.
1315 - 1316

9.16.94 CHANGE PER ECR 94-054

A

DATE **REVISION**

ISSUE

Mouser Electronics

Authorized Distributor

Click to View Pricing, Inventory, Delivery & Lifecycle Information:

[Keystone Electronics:](#)

[1316](#)