



60×60×38 mm

San Ace 60 9GA type Low Power Consumption Fan

General Specifications

- Material Frame: Plastic (Flammability: UL 94V-0), Impeller: Plastic (Flammability: UL 94V-0)
- Expected life See the table below. (L10 life: 90% survival rate for continuous operation in free air at 60°C, rated voltage)
- Motor protection function Locked rotor burnout protection, Reverse polarity protection
For details, please refer to p. 529.
- Dielectric strength 50/60 Hz, 500 VAC, for 1 minute (between lead wire conductors and frame)
- Insulation resistance 10 MΩ or more with a 500 VDC megger (between lead wire conductors and frame)
- Sound pressure level (SPL) At 1 m away from the air inlet
- Storage temperature -30 to +70°C (Non-condensing)
- Lead wire ⊕Red ⊖Black (Sensor) Yellow (Control) Brown
- Mass 130 g

Specifications

The models listed below **have ribs and pulse sensors with PWM control function.** For models without ribs, append "1" to the end of model numbers.

Model no.	Rated voltage [V]	Operating voltage range [V]	PWM duty cycle* [%]	Rated current [A]	Rated input [W]	Rated speed [min ⁻¹]	Max. airflow [m ³ /min] [CFM]	Max. static pressure [Pa] [inchH ₂ O]	SPL [dB (A)]	Operating temperature [°C]	Expected life [h]	
9GA0612P1J03**	12	10.8 to 12.6	100	1.5	18.0	17500	1.75 62	820 3.3	63	-20 to +60	40000/60°C (70000/40°C)	
			20	0.1	1.2	4000	0.4 14	43 0.17	24			
10.8 to 13.2		100	0.95	11.4	14800	1.5 53	600 2.4	59	-20 to +70			
		20	0.1	1.2	4000	0.4 14	43 0.17	24				
		100	0.55	6.6	11500	1.15 40	375 1.5	52				
		20	0.06	0.72	2600	0.27 9.5	20 0.08	19	-20 to +60			
		100	0.95	11.4	14800	1.5 53	675 2.7	59				
		0	0.05	0.6	1480	0.134 4.7	8.3 0.03	16				
9GA0624P1J03**		24	21.6 to 25.2	100	0.75	18.0	17500	1.75 62	820 3.3	63		-20 to +60
				20	0.1	2.4	6200	0.63 22	104 0.42	35		
21.6 to 26.4			100	0.5	12	14800	1.5 53.0	600 2.4	59	-20 to +70		
			20	0.06	1.44	5000	0.5 17.7	70 0.28	28			

* PWM frequency: 25 kHz ** Fan does not rotate when PWM duty cycle is 0%.

Other sensor specifications are available as options. Refer to the index (pp. 551 to 552).

Airflow - Static Pressure Characteristics / PWM Duty - Speed Characteristics Example

9GA0612P1J03 With pulse sensor with PWM control function

PWM duty cycle

Operating voltage range

PWM duty - Speed characteristics example

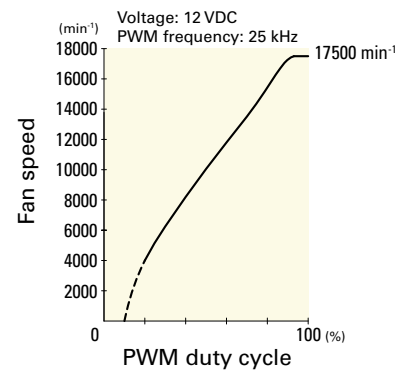
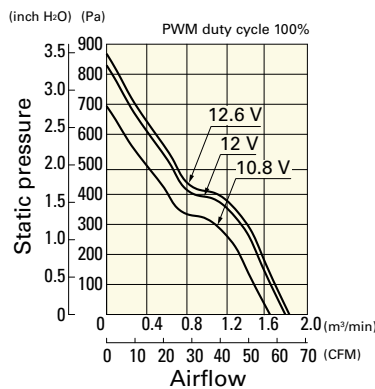
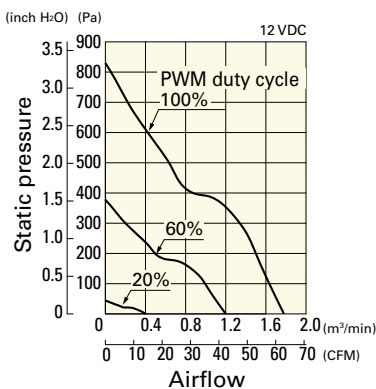

Airflow - Static Pressure Characteristics / PWM Duty - Speed Characteristics Example

9GA0612P1K03 With pulse sensor with PWM control function

PWM duty cycle

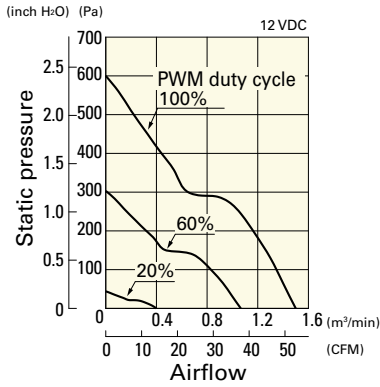

Operating voltage range

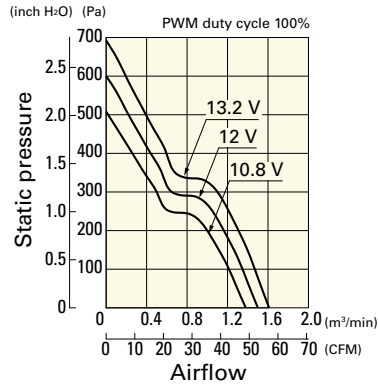

PWM duty - Speed characteristics example

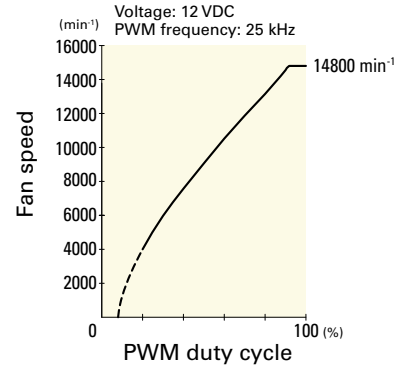

9GA0612P1H03 With pulse sensor with PWM control function

PWM duty cycle

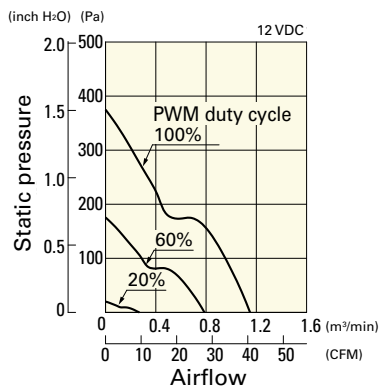

Operating voltage range

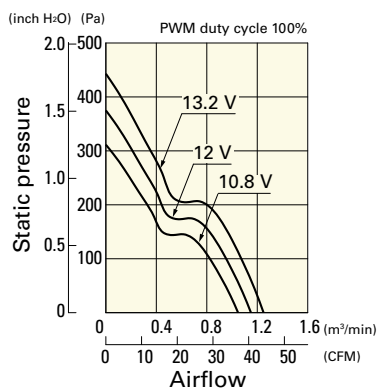

PWM duty - Speed characteristics example

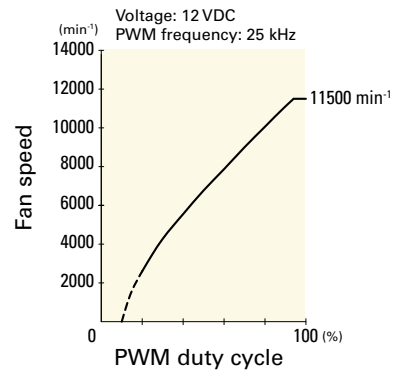

9GA0612P1K60 With pulse sensor with PWM control function

PWM duty cycle

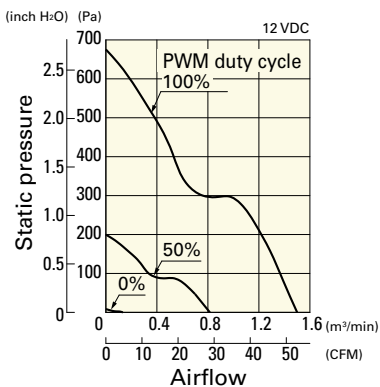

Operating voltage range

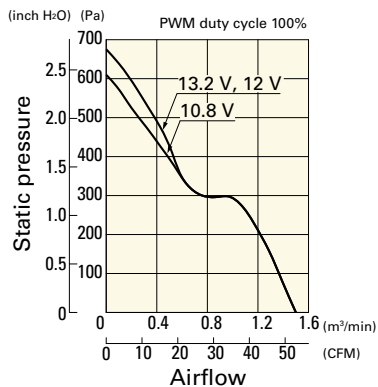

PWM duty - Speed characteristics example

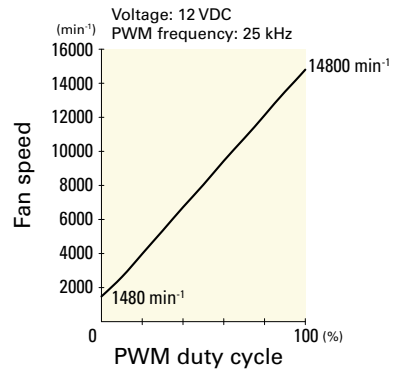

9GA0624P1J03 With pulse sensor with PWM control function

PWM duty cycle

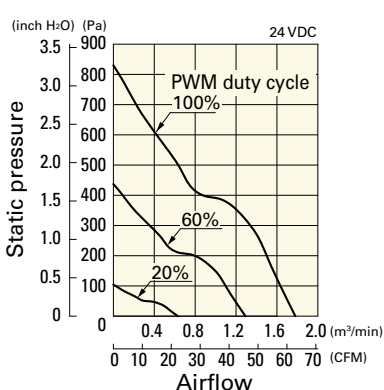

Operating voltage range

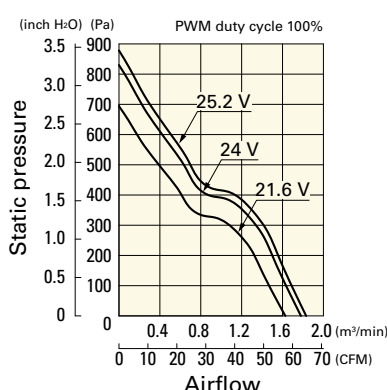

PWM duty - Speed characteristics example

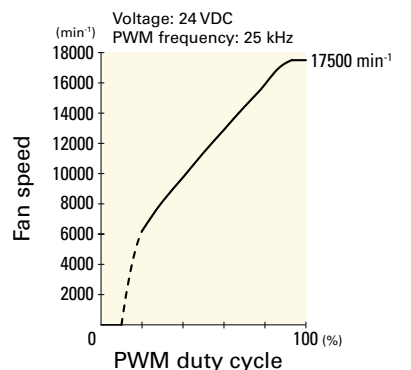

Airflow - Static Pressure Characteristics / PWM Duty - Speed Characteristics Example

9GA0624P1K03 With pulse sensor with PWM control function

PWM duty cycle

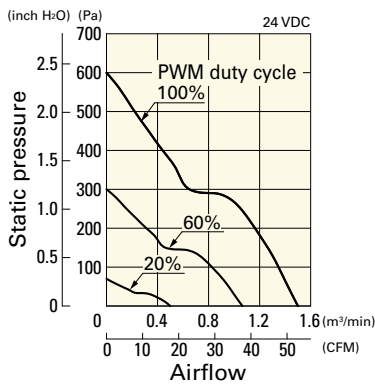

Operating voltage range

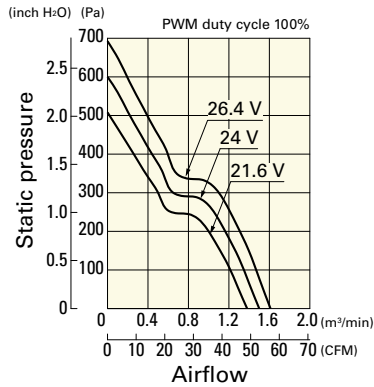

PWM duty - Speed characteristics example

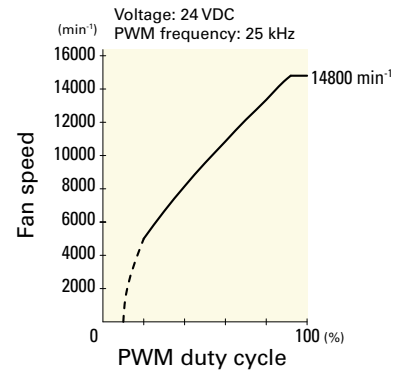

Dimensions (unit: mm) (With ribs)

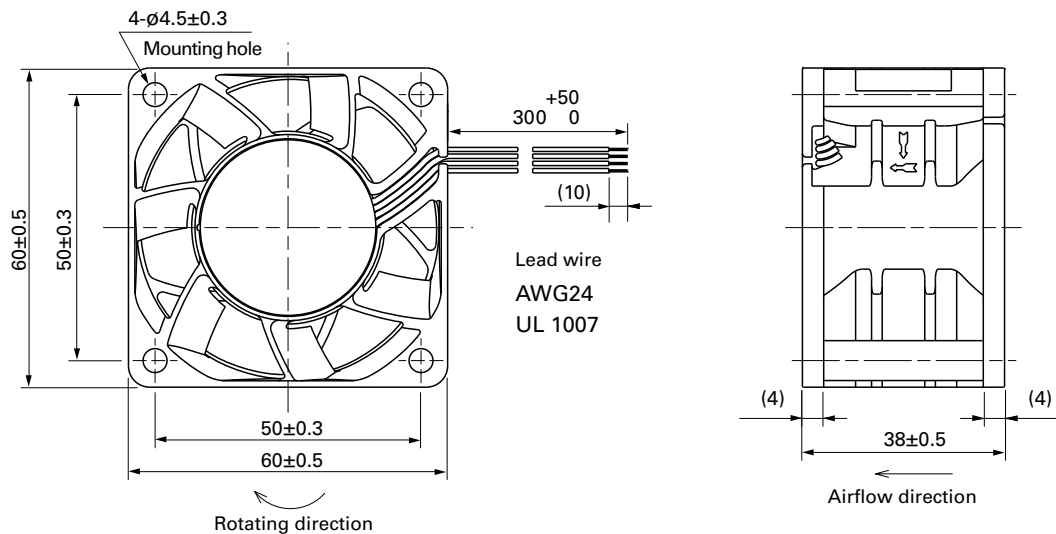

Reference Dimensions of Mounting Holes and Vent Opening (unit: mm)

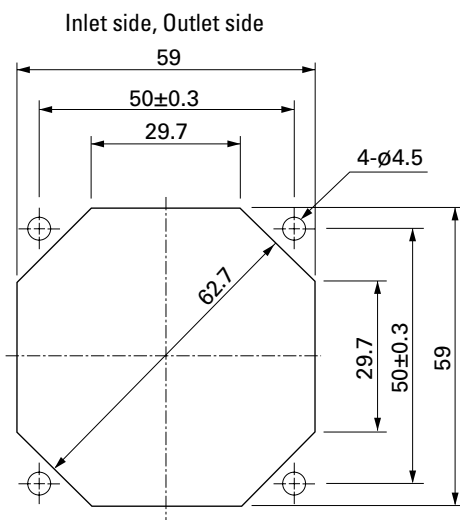

Options

Finger guards page: p. 513
Model no.: 109-139E, 109-139H

Resin finger guards page: p. 520
Model no.: 109-1003G

Resin filter kits page: p. 521
Model no.: 109-1003F13 (13PPI), 109-1003F20 (20PPI),
109-1003F30 (30PPI), 109-1003F40 (40PPI)

Mouser Electronics

Authorized Distributor

Click to View Pricing, Inventory, Delivery & Lifecycle Information:

Sanyo Denki:

[9GA0612P1J031](#) [9GA0612P1K031](#) [9GA0612P1H031](#) [9GA0612P1K03](#) [9GA0612P1K601](#) [9GA0612P1H03](#)
[9GA0612P1J03](#) [9GA0624P1J031](#) [9GA0624P1K03](#) [9GA0624P1K031](#) [9GA0624P1J03](#) [9GA0612P1K60](#)
[9GA0612J101](#) [9GA0624J101](#) [9GA0624J1011](#) [9GA0612H101](#) [9GA0612H1011](#) [9GA0624J102](#) [9GA0624J1021](#)
[9GA0612H102](#) [9GA0612H1021](#) [9GA0612J1011](#) [9GA0612J102](#) [9GA0612J1021](#) [9GA0612J1D01](#) [9GA0612K101](#)
[9GA0612K1011](#) [9GA0612K102](#) [9GA0612K1021](#) [9GA0612K1D011](#)