

## DAC5675A 14-Bit, 400-MSPS Digital-to-Analog Converter

### 1 Features

- 400MSPS Update Rate
- LVDS-Compatible Input Interface
- Spurious-Free Dynamic Range (SFDR) to Nyquist:
  - 69dBc at 70MHz IF, 400MSPS
- W-CDMA Adjacent Channel Power Ratio (ACPR):
  - 73dBc at 30.72MHz IF, 122.88MSPS
  - 71dBc at 61.44MHz IF, 245.76MSPS
- Differential Scalable Current Sink Outputs: 2mA to 20mA
- On-Chip 1.2V Reference
- Single 3.3V Supply Operation
- Power Dissipation: 660mW at  $f_{CLK} = 400\text{MSPS}$ ,  $f_{OUT} = 20\text{MHz}$
- Package: 48-Pin HTQFP PowerPad™,  $T_{JA} = 28.8^\circ\text{C/W}$

### 2 Applications

- Cellular Base Transceiver Station Transmit Channel:
  - CDMA: WCDMA, CDMA2000, IS-95
  - TDMA: GSM, IS-136, EDGE/GPRS
  - Supports Single-Carrier and Multicarrier Applications
- Test and Measurement: Arbitrary Waveform Generation
- Direct Digital Synthesis (DDS)
- Cable Modem Headend

### 3 Description

The DAC5675A is a 14-bit resolution high-speed digital-to-analog converter. The DAC5675A is designed for high-speed digital data transmission in wired and wireless communication systems, high-frequency direct-digital synthesis (DDS), and waveform reconstruction in test and measurement applications. The DAC5675A has excellent spurious-free dynamic range (SFDR) at high intermediate frequencies, which makes the DAC5675A well-suited for multicarrier transmission in TDMA- and CDMA-based cellular base transceiver stations (BTSs).

The DAC5675A operates from a single-supply voltage of 3.3 V. Power dissipation is 660 mW at  $f_{CLK} = 400\text{ MSPS}$ ,  $f_{OUT} = 70\text{ MHz}$ . The DAC5675A provides a nominal full-scale differential current output of 20mA, supporting both single-ended and differential applications. The output current can be directly fed to the load with no additional external output buffer required. The output is referred to the analog supply voltage  $AV_{DD}$ .

The DAC5675A comprises a low-voltage differential signaling (LVDS) interface for high-speed digital data input. LVDS features a low differential voltage swing with a low constant power consumption across frequency, allowing for high-speed data transmission with low noise levels; that is, with low electromagnetic interference (EMI). LVDS is typically implemented in low-voltage digital CMOS processes, making it the ideal technology for high-speed interfacing between the DAC5675A and high-speed low-voltage CMOS ASICs or FPGAs. The DAC5675A current-sink-array architecture supports update rates of up to 400MSPS. On-chip edge-triggered input latches provide for minimum setup and hold times, thereby relaxing interface timing.

#### Device Information<sup>(1)</sup>

PART NUMBER	PACKAGE	BODY SIZE (NOM)
DAC5675A	PHP (48)	7.00 mm x 7.00 mm

(1) For all available packages, see the orderable addendum at the end of the data sheet.

#### Simple Schematic

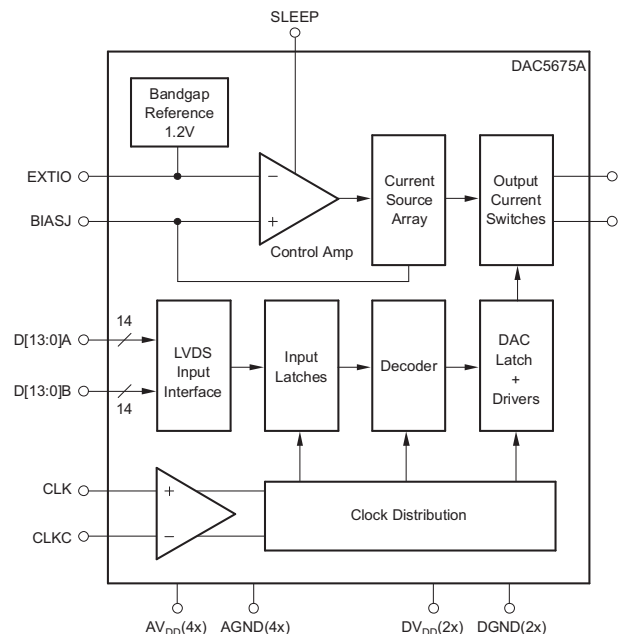

Copyright © 2016, Texas Instruments Incorporated



## Table of Contents

<b>1</b>	<b>Features</b> .....	<b>1</b>	8.2	Functional Block Diagram .....	<b>12</b>
<b>2</b>	<b>Applications</b> .....	<b>1</b>	8.3	Feature Description.....	<b>12</b>
<b>3</b>	<b>Description</b> .....	<b>1</b>	8.4	Device Functional Modes.....	<b>19</b>
<b>4</b>	<b>Revision History</b> .....	<b>2</b>	<b>9</b>	<b>Application and Implementation</b> .....	<b>20</b>
<b>5</b>	<b>Description Continued</b> .....	<b>2</b>	9.1	Application Information.....	<b>20</b>
<b>6</b>	<b>Pin Configuration and Functions</b> .....	<b>3</b>	9.2	Typical Application .....	<b>20</b>
<b>7</b>	<b>Specifications</b> .....	<b>4</b>	<b>10</b>	<b>Power Supply Recommendations</b> .....	<b>21</b>
7.1	Absolute Maximum Ratings .....	<b>4</b>	<b>11</b>	<b>Layout</b> .....	<b>22</b>
7.2	ESD Ratings.....	<b>4</b>	11.1	Layout Guidelines .....	<b>22</b>
7.3	Recommended Operating Conditions.....	<b>5</b>	11.2	Layout Example .....	<b>22</b>
7.4	Thermal Information .....	<b>5</b>	<b>12</b>	<b>Device and Documentation Support</b> .....	<b>24</b>
7.5	DC Electrical Characteristics .....	<b>6</b>	12.1	Receiving Notification of Documentation Updates	<b>24</b>
7.6	AC Electrical Characteristics.....	<b>7</b>	12.2	Community Resources.....	<b>24</b>
7.7	Digital Specifications.....	<b>8</b>	12.3	Trademarks .....	<b>24</b>
7.8	Operational Characteristics .....	<b>8</b>	12.4	Electrostatic Discharge Caution.....	<b>24</b>
7.9	Typical Characteristics.....	<b>10</b>	12.5	Glossary .....	<b>24</b>
<b>8</b>	<b>Detailed Description</b> .....	<b>12</b>	12.6	Device Nomenclature.....	<b>24</b>
8.1	Overview .....	<b>12</b>	<b>13</b>	<b>Mechanical, Packaging, and Orderable Information</b> .....	<b>25</b>

## 4 Revision History

NOTE: Page numbers for previous revisions may differ from page numbers in the current version.

### Changes from Revision C (March 2005) to Revision D

Page

- Added *ESD Ratings*, *Recommended Operating Conditions*, *Thermal Information*, *Detailed Description* section, *Application and Implementation* section, *Power Supply Recommendations* section, *Layout* section, *Device and Documentation Support* section, *Mechanical, Packaging, and Orderable Information* section..... **1**
- Changed AV<sub>DD</sub> to DV<sub>DD</sub> From: –3.6 to +3.6 To: –0.7 to +0.7 in the *Absolute Maximum Ratings* .....

## 5 Description Continued

The DAC5675A has been specifically designed for a differential transformer-coupled output with a 50 Ω doubly-terminated load. With the 20 mA full-scale output current, both a 4:1 impedance ratio (resulting in an output power of 4 dBm) and 1:1 impedance ratio transformer (–2 dBm) are supported. The last configuration is preferred for optimum performance at high output frequencies and update rates. The outputs are terminated to AV<sub>DD</sub> and have voltage compliance ranges from AV<sub>DD</sub> –1 to AV<sub>DD</sub> + 0.3 V.

An accurate on-chip 1.2-V temperature-compensated bandgap reference and control amplifier allows the user to adjust this output current from 20 mA down to 2 mA. This provides 20-dB gain range control capabilities. Alternatively, an external reference voltage may be applied. The DAC5675A features a SLEEP mode, which reduces the standby power to approximately 18 mW.

The DAC5675A is available in a 48-pin HTQFP thermally-enhanced PowerPad package. This package increases thermal efficiency in a standard size IC package. The device is characterized for operation over the industrial temperature range of –40°C to +85°C.

## 6 Pin Configuration and Functions

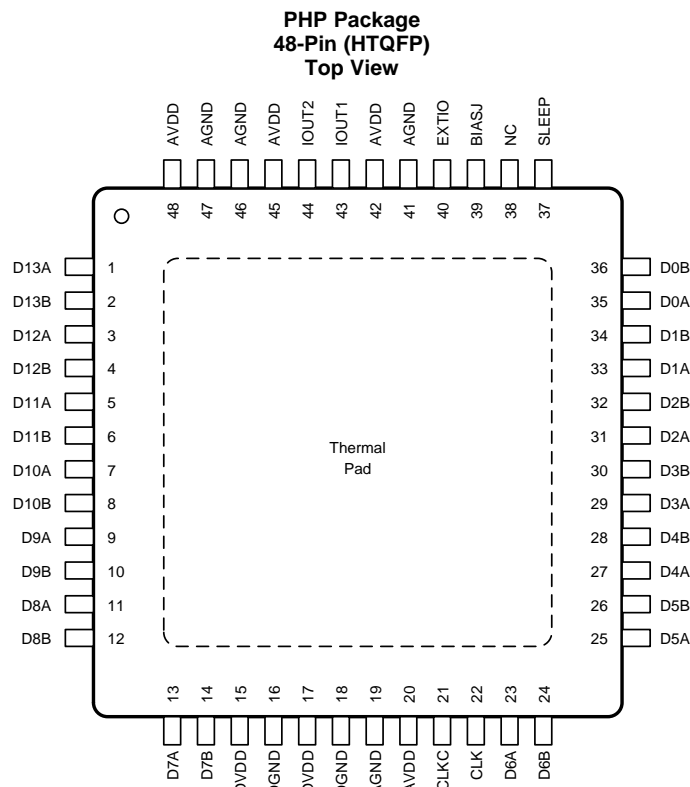

Note: Thermal pad size: 4.5 mm x 4.5 mm (min), 5.5 mm x 5.5 mm (max)

### Pin Functions

PIN		I/O	DESCRIPTION
NAME	NO.		
AGND	19, 41, 46, 47	I	Analog negative supply voltage (ground); pin 47 internally connected to PowerPAD.
AVDD	20, 42, 45, 48	I	Analog positive supply voltage.
BIASJ	39	O	Full-scale output current bias.
CLK	22	I	External clock input.
CLKC	21	I	Complementary external clock input.
D(13:0)A	1, 3, 5, 7, 9, 11, 13, 23, 25, 27, 29, 31, 33, 35	I	LVDS positive input, data bits 0 through 13. D13A is most significant data bit (MSB). D0A is least significant data bit (MSB).
D(13:0)B	2, 4, 6, 8, 10, 12, 14, 24, 26, 28, 30, 32, 34, 36	I	LVDS negative input, data bits 0 through 13. D13B is most significant data bit (MSB). D0B is least significant data bit (MSB).
DGND	16, 18	I	Digital negative supply voltage (ground).
NC	38	—	Not connected in chip. Can be high or low.
DVDD	15, 17	I	Digital positive supply voltage.
EXTIO	40	I/O	Internal reference output or external reference input. Requires a 0.1 $\mu$ F decoupling capacitor to AGND when used as reference output.
IOUT1	43	O	DAC current output. Full-scale when all input bits are set to '0'. Connect reference side of DAC load resistors to AV <sub>DD</sub> .
IOUT2	44	O	DAC complementary current output. Full-scale when all input bits are set to '1'. Connect reference side of DAC load resistors to AV <sub>DD</sub> .
SLEEP	37	I	Asynchronous hardware power down input. Active high. Internal pull-down.

## 7 Specifications

### 7.1 Absolute Maximum Ratings

over operating free-air temperature range (unless otherwise noted)<sup>(1)</sup>

		MIN	MAX	UNIT
Supply voltage range	$AV_{DD}$ <sup>(2)</sup>	-0.3	+3.6	V
	$DV_{DD}$ <sup>(3)</sup>	-0.3	+3.6	V
	$AV_{DD}$ to $DV_{DD}$	-0.7	+0.7	V
Voltage between AGND and DGND		-0.3	+0.5	V
CLK, CLKC <sup>(2)</sup>		-0.3	$AV_{DD} + 0.3$	V
Digital input D[13:0]A, D[13:0]B(3), SLEEP		-0.3	$DV_{DD} + 0.3$	V
IOUT1, IOUT2 <sup>(2)</sup>		-1.0	$AV_{DD} + 0.3$	V
EXTIO, BIAS <sup>(2)</sup>		-1.0	$AV_{DD} + 0.3$	V
Peak input current (any input)			20	mA
Peak total input current (all inputs)			-30	mA
Operating free-air temperature range, $T_A$		-40	+85	°C
Storage temperature range		-65	+150	°C

- (1) Stresses above those listed under *Absolute Maximum Ratings* may cause permanent damage to the device. Exposure outside of absolute maximum conditions for extended periods may degrade device reliability. These are stress ratings only, and functional operation of the device at these or any other conditions beyond those indicated under recommended operating conditions is not implied. Exposure to absolute-maximum-rated conditions for extended periods may affect device reliability.
- (2) Measured with respect to AGND.
- (3) Measured with respect to DGND.

### 7.2 ESD Ratings

		VALUE	UNIT
$V_{(ESD)}$ Electrostatic discharge	Human-body model (HBM), per ANSI/ESDA/JEDEC JS-001 <sup>(1)</sup>	±1000	V
	Charged-device model (CDM), per JEDEC specification JESD22-C101 <sup>(2)</sup>	±250	

- (1) JEDEC document JEP155 states that 500-V HBM allows safe manufacturing with a standard ESD control process.
- (2) JEDEC document JEP157 states that 250-V CDM allows safe manufacturing with a standard ESD control process.

### 7.3 Recommended Operating Conditions

over operating free-air temperature range (unless otherwise noted)

		MIN	NOM	MAX	UNIT
<b>Supplies</b>					
AVDD		3.15	3.3	3.6	V
DVDD		3.15	3.3	3.6	V
$I_{(AVDD)}$	Analog supply current		115		mA
$I_{(DVDD)}$	Digital supply current		85		mA
<b>Analog Output</b>					
$I_{O(FS)}$	Full-scale output current	2		20	mA
	Output compliance range	$AV_{DD} - 1$		$AV_{DD} + 0.3$	V
<b>Clock Interface (CLK, CLKC)</b>					
	CLKINPUT Frequency			400	MHz
	$ CLK - CLKC $	0.4		0.8	$V_{PP}$
	Clock duty cycle	40%		60%	
$V_{CM}$	Common-mode voltage range	1.6	2	2.4	V

### 7.4 Thermal Information

THERMAL METRIC <sup>(1)</sup>		DAC5675A	UNIT
		PHP (HTQFP)	
		48 PINS	
$R_{\theta JA}$	Junction-to-ambient thermal resistance	31.3	°C/W
$R_{\theta JC(top)}$	Junction-to-case (top) thermal resistance	13.0	°C/W
$R_{\theta JB}$	Junction-to-board thermal resistance	10.9	°C/W
$\Psi_{JT}$	Junction-to-top characterization parameter	0.3	°C/W
$\Psi_{JB}$	Junction-to-board characterization parameter	10.9	°C/W
$R_{\theta JC(bot)}$	Junction-to-case (bottom) thermal resistance	0.9	°C/W

(1) For more information about traditional and new thermal metrics, see the [SPRA953 Semiconductor and IC Package Thermal Metrics](#) application report.

## 7.5 DC Electrical Characteristics

Over operating free-air temperature range. Typical values at +25°C,  $AV_{DD} = 3.3V$ ,  $DV_{DD} = 3.3V$ ,  $I_{O(FS)} = 20mA$ , unless otherwise noted.

PARAMETER		TEST CONDITIONS	MIN	TYP	MAX	UNIT
<b>Resolution</b>			14			Bit
<b>DC Accuracy<sup>(1)</sup></b>						
INL	Integral nonlinearity	$T_{MIN}$ to $T_{MAX}$	-4	±1.5	4	LSB
DNL	Differential nonlinearity		-2	±0.6	2	LSB
Monotonicity			Monotonic 12b Level			
<b>Analog Output</b>						
$I_{O(FS)}$	Full-scale output current		2		20	mA
	Output compliance range	$AV_{DD} = 3.15V$ to $3.45V$ , $I_{O(FS)} = 20mA$	$AV_{DD} - 1$		$AV_{DD} + 0.3$	V
	Offset error			0.01		%FSR
	Gain error	Without internal reference	-10	5	10	%FSR
		With internal reference	-10	2.5	10	%FSR
	Output resistance			300		kΩ
	Output capacitance			5		pF
<b>Reference Output</b>						
$V_{(EXTIO)}$	Reference voltage		1.17	1.23	1.29	V
	Reference output current <sup>(2)</sup>			100		nA
<b>Reference Input</b>						
$V_{(EXTIO)}$	Input reference voltage		0.6	1.2	1.25	V
	Input resistance			1		MΩ
	Small-signal bandwidth			1.4		MHz
	Input capacitance			100		pF
<b>Temperature Coefficients</b>						
	Offset drift			12		ppm of FSR/°C
$\Delta V_{(EXTIO)}$	Reference voltage drift			±50		ppm/°C
<b>Power Supply</b>						
$AV_{DD}$	Analog supply voltage		3.15	3.3	3.6	V
$DV_{DD}$	Digital supply voltage		3.15	3.3	3.6	V
$I_{(AVDD)}$	Analog supply current <sup>(3)</sup>			115		mA
$I_{(DVDD)}$	Digital supply current <sup>(3)</sup>			85		mA
$P_D$	Power dissipation	Sleep mode		18		mW
$P_D$	Power dissipation	$AV_{DD} = 3.3V$ , $DV_{DD} = 3.3V$		660	900	mW
APSR	Analog and digital power-supply rejection ratio	$AV_{DD} = 3.15V$ to $3.45V$	-0.5	±0.1	0.5	%FSR/V
DPSRR			-0.5	±0.1	0.5	%FSR/V

(1) Measured differential at  $I_{OUT1}$  and  $I_{OUT2}$ ; 25Ω to  $AV_{DD}$ .

(2) Use an external buffer amplifier with high impedance input to drive any external load.

(3) Measured at  $f_{CLK} = 400MSPS$  and  $f_{OUT} = 70MHz$ .

## 7.6 AC Electrical Characteristics

Over operating free-air temperature range. Typical values at +25°C,  $AV_{DD} = 3.3V$ ,  $DV_{DD} = 3.3V$ ,  $I_{O(FS)} = 20mA$ , differential transformer-coupled output, 50Ω doubly-terminated load, unless otherwise noted.

PARAMETER		TEST CONDITIONS	MIN	TYP	MAX	UNIT
<b>Analog Output</b>						
$f_{CLK}$	Output update rate				400	MSPS
$t_{s(DAC)}$	Output setting time to 0.1%	Transition: code x2000 to x23FF		12		ns
$t_{PD}$	Output propagation delay			1		ns
$t_{r(IOUT)}$	Output rise time, 10% to 90%			300		ps
$t_{f(IOUT)}$	Output fall time, 90% to 10%			300		ps
	Output noise <sup>(1)</sup>	$I_{OUT_{FS}} = 20mA$		55		$\mu A/\sqrt{Hz}$
		$I_{OUT_{FS}} = 2mA$		30		$\mu A/\sqrt{Hz}$
<b>AC Linearity</b>						
THD	Total harmonic distortion	$f_{CLK} = 100MSPS, f_{OUT} = 19.9MHz$		73		dBc
		$f_{CLK} = 160MSPS, f_{OUT} = 41MHz$		72		dBc
		$f_{CLK} = 200MSPS, f_{OUT} = 70MHz$		68		dBc
		$f_{CLK} = 400MSPS, f_{OUT} = 20.1MHz$		72		dBc
		$f_{CLK} = 400MSPS, f_{OUT} = 70MHz$		71		dBc
		$f_{CLK} = 400MSPS, f_{OUT} = 140MHz$		58		dBc
SFDR	Spurious-free dynamic range to Nyquist	$f_{CLK} = 100MSPS, f_{OUT} = 19.9MHz$		73		dBc
		$f_{CLK} = 160MSPS, f_{OUT} = 41MHz$		73		dBc
		$f_{CLK} = 200MSPS, f_{OUT} = 70MHz$		70		dBc
		$f_{CLK} = 400MSPS, f_{OUT} = 20.1MHz$		73		dBc
		$f_{CLK} = 400MSPS, f_{OUT} = 70MHz$		74		dBc
		$f_{CLK} = 400MSPS, f_{OUT} = 140MHz$		60		dBc
SFDR	Spurious-free dynamic range within a window, 5MHz span	$f_{CLK} = 100MSPS, f_{OUT} = 19.9MHz$		88		dBc
		$f_{CLK} = 160MSPS, f_{OUT} = 41MHz$		87		dBc
		$f_{CLK} = 200MSPS, f_{OUT} = 70MHz$		82		dBc
		$f_{CLK} = 400MSPS, f_{OUT} = 20.1MHz$		87		dBc
		$f_{CLK} = 400MSPS, f_{OUT} = 70MHz$		82		dBc
		$f_{CLK} = 400MSPS, f_{OUT} = 140MHz$		75		dBc
ACPR	Adjacent channel power ratio WCDMA with 3.84MHz BW, 5MHz channel spacing	$f_{CLK} = 122.88MSPS, IF = 30.72MHz^{(2)}$		73		dB
		$f_{CLK} = 245.76MSPS, IF = 61.44MHz^{(3)}$		71		dB
		$f_{CLK} = 399.32MSPS, IF = 153.36MHz^{(4)}$		65		dB
IMD	Two-tone intermodulation to Nyquist (each tone at -6dBfs)	$f_{CLK} = 400MSPS, f_{OUT1} = 70MHz, f_{OUT2} = 71MHz$		73		dBc
		$f_{CLK} = 400MSPS, f_{OUT1} = 140MHz, f_{OUT2} = 141MHz$		62		dBc
	Four-tone intermodulation, 15MHz span, missing center tone (each tone at -16dBfs)	$f_{CLK} = 156MSPS, f_{OUT} = 15.6, 15.8, 16.2, 16.4MHz$		82		dBc
		$f_{CLK} = 400MSPS, f_{OUT} = 68.1, 69.3, 71.2, 72MHz$		74		dBc

(1) Noise averaged up to 400MHz when operating at 400MSPS.

(2) See Figure 9.

(3) See Figure 10.

(4) See Figure 12

## 7.7 Digital Specifications

Over operating free-air temperature range. Typical values at +25°C,  $AV_{DD} = 3.3V$ ,  $DV_{DD} = 3.3V$ , unless otherwise noted.

PARAMETER		TEST CONDITIONS	MIN	TYP	MAX	UNIT
<b>LVDS Interface: nodes D[13:0]A, D[13:0]B</b>						
$V_{ITH+}$	Positive-going differential input voltage threshold	See LVDS min/max threshold voltages table		100		mV
$V_{ITH-}$	Negative-going differential input voltage threshold			-100		mV
$Z_T$	Internal termination impedance		90	110	132	$\Omega$
$C_I$	Input capacitance			2		pF
<b>CMOS Interface (SLEEP):</b>						
$V_{IH}$	High-level input voltage		2	3.3		V
$V_{IL}$	Low-level input voltage			0	0.8	V
$I_{IH}$	High-level input current		-100		100	$\mu A$
$I_{IL}$	Low-level input current		-10		10	$\mu A$
	Input capacitance			2		pF
<b>Clock Interface (CLK, CLKC):</b>						
$ \text{CLK-CLKC} $	Clock differential input voltage		0.4		0.8	$V_{PP}$
	Clock duty cycle		40%		60%	
$V_{CM}$	Common-mode voltage range			$2 \pm 20\%$		V
	Input resistance	Node CLK, CLKC		670		$\Omega$
	Input capacitance	Node CLK, CLKC		2		pF
	Input resistance	Differential		1.3		k $\Omega$
	Input capacitance	Differential		1		pF
<b>Timing</b>						
$t_{SU}$	Input setup time		1.5			ns
$t_H$	Input hold time		0			ns
$t_{DD}$	Digital delay time (DAC latency)			3		clk

## 7.8 Operational Characteristics<sup>(1)</sup>

Over operating free-air temperature range,  $AV_{DD} = 3.3V$ ,  $DV_{DD} = 3.3V$ ,  $I_{O(FS)} = 20mA$ , unless otherwise noted.

APPLIED VOLTAGES		RESULTING DIFFERENTIAL INPUT VOLTAGE	RESULTING COMMON-MODE INPUT VOLTAGE	LOGICAL BIT BINARY EQUIVALENT	COMMENT
$V_A$ [V]	$V_B$ [V]	$V_{A,B}$ [mV]	$V_{COM}$ [V]		
1.25	1.15	100	1.2	1	Operation with minimum differential voltage ( $\pm 100mV$ ) applied to the complementary inputs versus common-mode range
1.15	1.25	-100	1.2	0	
2.4	2.3	100	2.35	1	
2.3	2.4	-100	2.35	0	
0.1	0	100	0.05	1	
0	0.1	-100	0.05	0	
1.5	0.9	600	1.2	1	Operation with maximum differential voltage ( $\pm 600mV$ ) applied to the complementary inputs versus common-mode range
0.9	1.5	-600	1.2	0	
2.4	1.8	600	2.1	1	
1.8	2.4	-600	2.1	0	
0.6	0	600	0.3	1	
0	0.6	-600	0.3	0	

(1) Specifications subject to change.



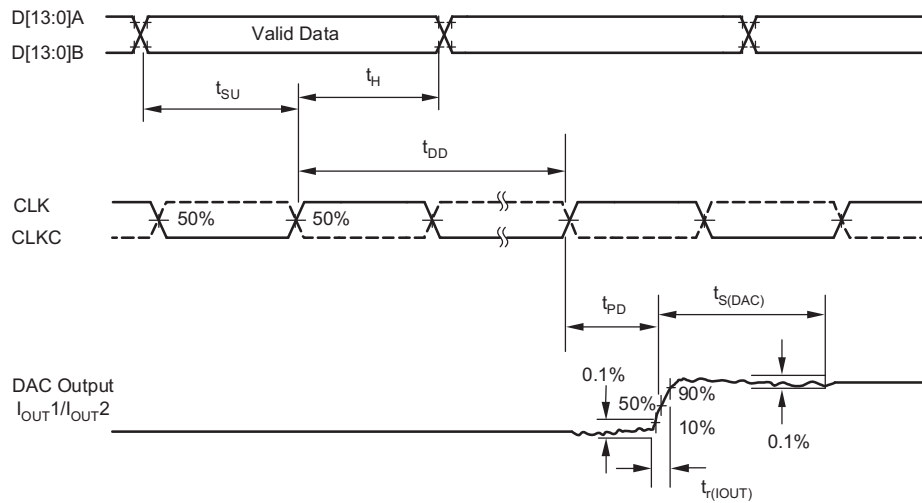

Figure 1. Timing Diagram

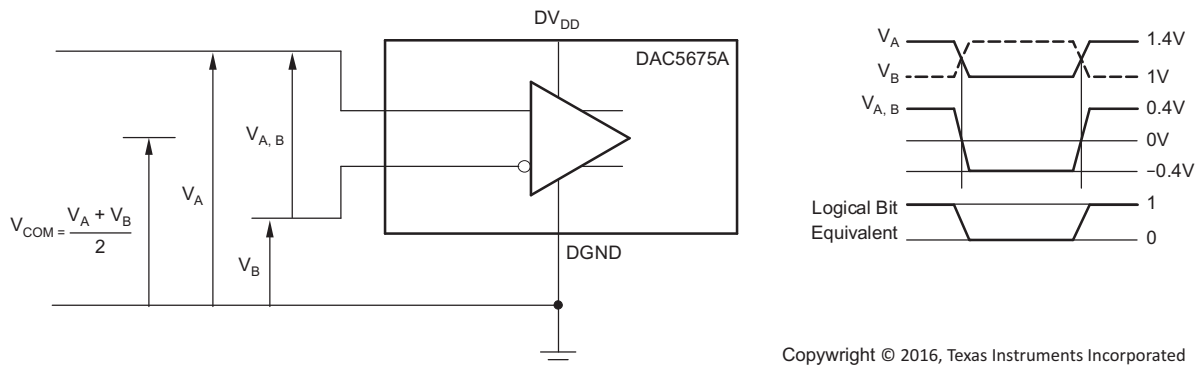

Figure 2. LVDS Timing Test Circuit and Input Test Levels

Copyright © 2016, Texas Instruments Incorporated

### 7.9 Typical Characteristics

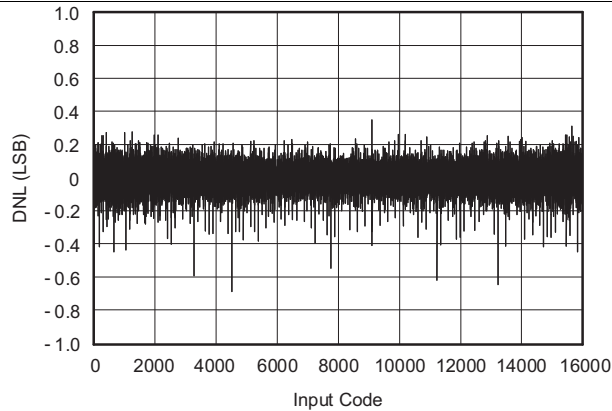

Figure 3. Differential Non-Linearity (DNL) vs Input Code

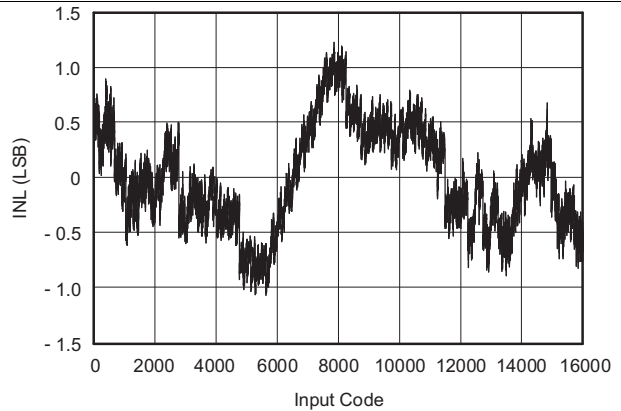

Figure 4. Integral Non-Linearity (INL) vs Input Code

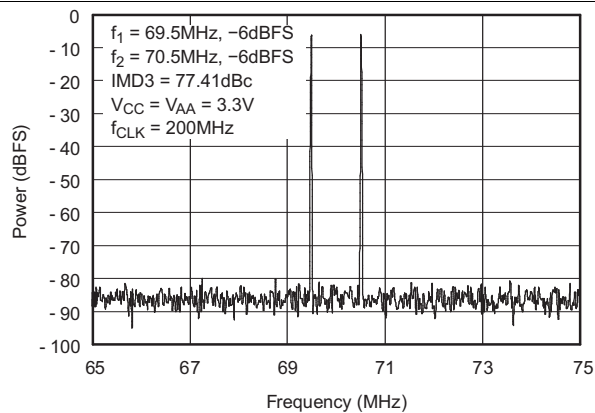

Figure 5. Two-Tone IMD (Power) vs Frequency

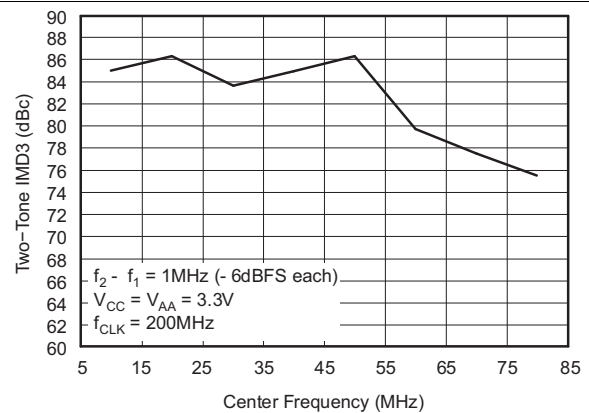

Figure 6. Two-Tone IMD3 vs Frequency

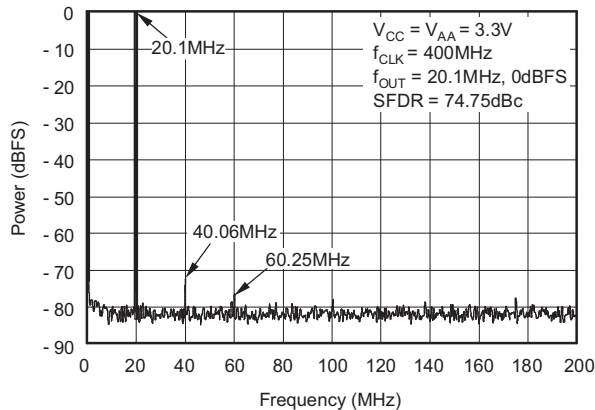

Figure 7. Single-Tone Spectrum Power vs Frequency

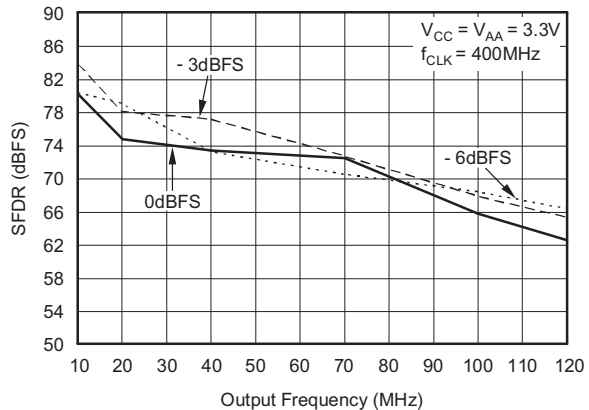

Figure 8. Spurious-Free Dynamic Range vs Frequency

Typical Characteristics (continued)

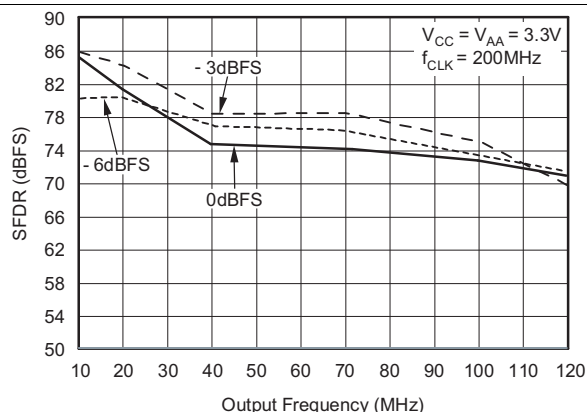

Figure 9. Spurious-Free Dynamic Range vs Frequency

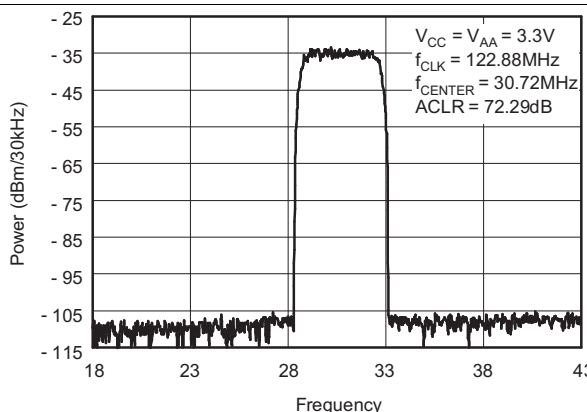

Figure 10. W-CDMA TM1 Single Carrier Power vs Frequency

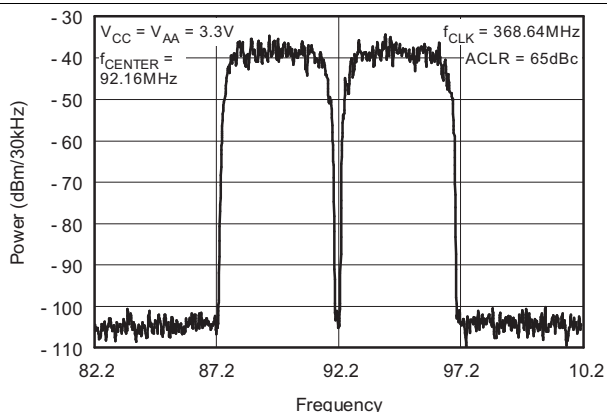

Figure 11. W-CDMA TM1 Dual Carrier Power vs Frequency

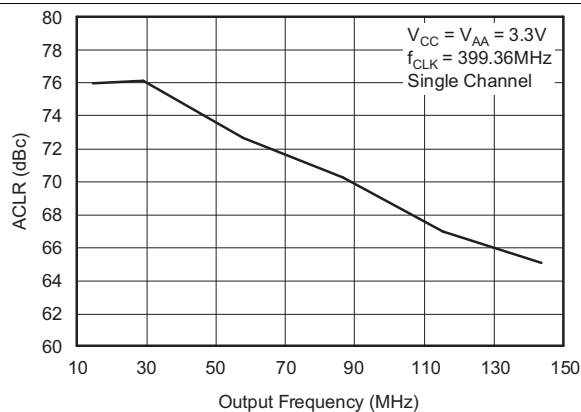

Figure 12. W-CDMA TM1 Single Carrier ACLR vs Output Frequency

## 8 Detailed Description

### 8.1 Overview

The DAC5675A is a 14-bit resolution high-speed digital-to-analog converter. The DAC5675A is designed for high-speed digital data transmission in wired and wireless communication systems, high frequency direct-digital synthesis (DDS), and waveform reconstruction in test and measurement applications. The DAC5675A has excellent spurious free dynamic range (SFDR) at high intermediate frequencies, which makes the DAC5675A well-suited for multicarrier transmission in TDMA- and CDMA based cellular base transceiver stations (BTSs).

### 8.2 Functional Block Diagram

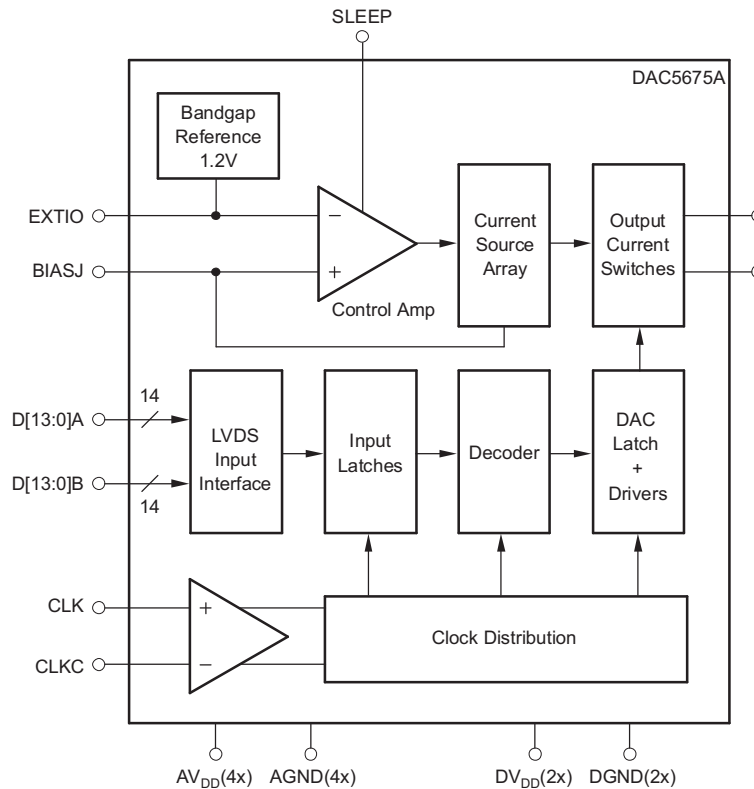

Copyright © 2016, Texas Instruments Incorporated

### 8.3 Feature Description

#### 8.3.1 Digital Inputs

The DAC5675A uses a low voltage differential signaling (LVDS) bus input interface. The LVDS features a low differential voltage swing with low constant power consumption ( $\approx 4\text{mA}$  per complementary data input) across frequency. The differential characteristic of LVDS allows for high-speed data transmission with low electromagnetic interference (EMI) levels. The LVDS input minimum and maximum input threshold table lists the LVDS input levels. [Figure 13](#) shows the equivalent complementary digital input interface for the DAC5675A, valid for pins D[13:0]A and D[13:0]B. Note that the LVDS interface features internal  $110\Omega$  resistors for proper termination. [Figure 2](#) shows the LVDS input timing measurement circuit and waveforms. A common-mode level of  $1.2\text{V}$  and a differential input swing of  $0.8V_{PP}$  is applied to the inputs.

[Figure 14](#) shows a schematic of the equivalent CMOS/TTL-compatible digital inputs of the DAC5675A, valid for the SLEEP pin.

Feature Description (continued)

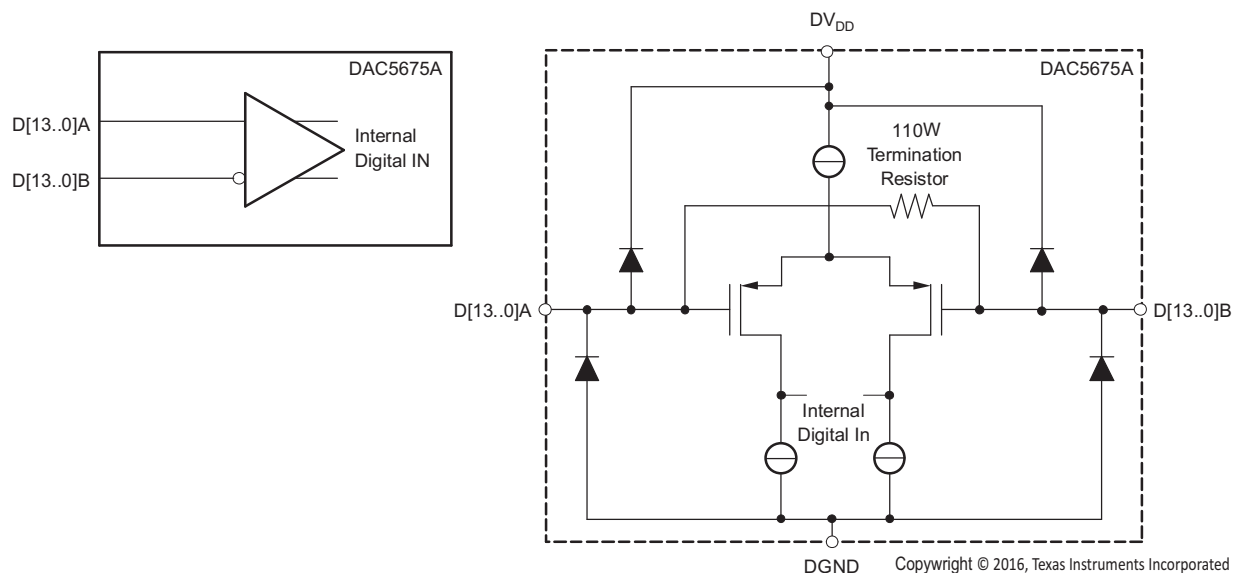

Figure 13. LVDS Digital Equivalent Input

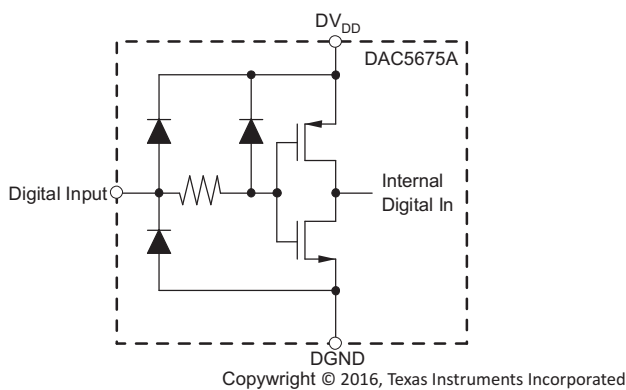

Figure 14. CMOS/TTL Digital Equivalent Input

## Feature Description (continued)

### 8.3.2 Clock Input

The DAC5675A features differential, LVPECL compatible clock inputs (CLK, CLKC). Figure 15 shows the equivalent schematic of the clock input buffer. The internal biasing resistors set the input common-mode voltage to approximately 2V, while the input resistance is typically 670Ω. A variety of clock sources can be ac-coupled to the device, including a sine wave source (see Figure 16).

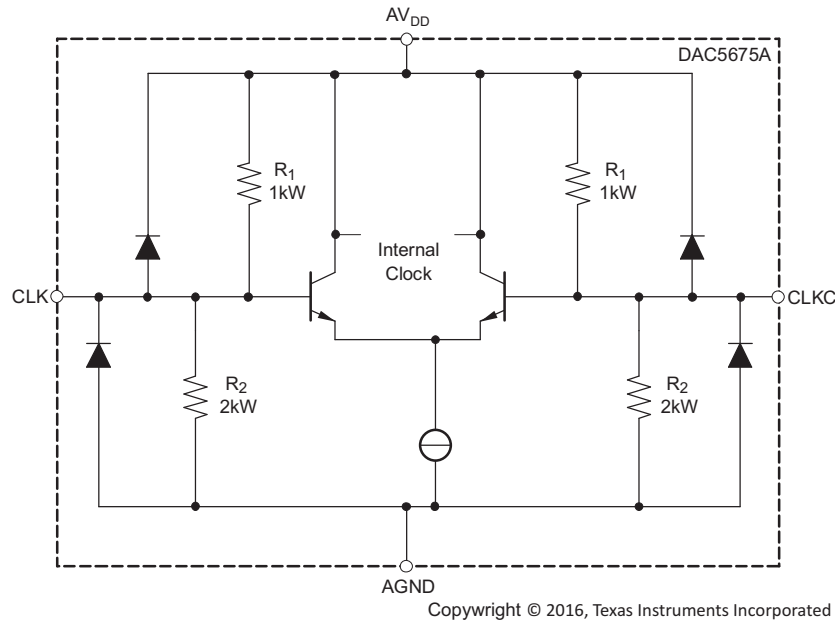

Figure 15. Clock Equivalent Input

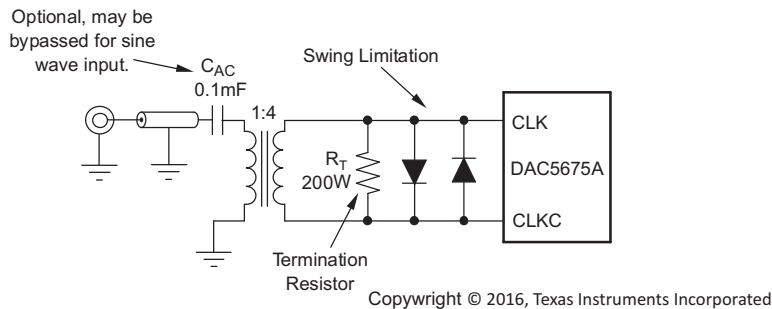
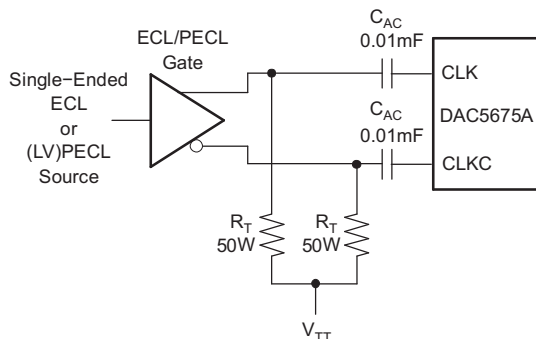

Figure 16. Driving the DAC5675A with a Single-Ended Clock Source Using a Transformer

To obtain best ac performance the DAC5675A clock input should be driven with a differential LVPECL or sine wave source as shown in Figure 17 and Figure 18. Here, the potential of  $V_{TT}$  should be set to the termination voltage required by the driver along with the proper termination resistors ( $R_T$ ). The DAC5675A clock input can also be driven single-ended; this is shown in Figure 19.

Feature Description (continued)



Copyright © 2016, Texas Instruments Incorporated

Figure 17. Driving the DAC5675A with a Single-Ended ECL/PECL Clock Source

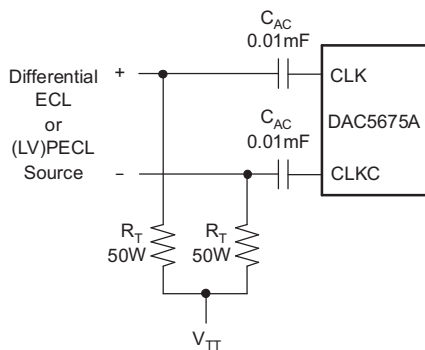

Copyright © 2016, Texas Instruments Incorporated

Figure 18. Driving the DAC5675A with a Differential ECL/PECL Clock Source

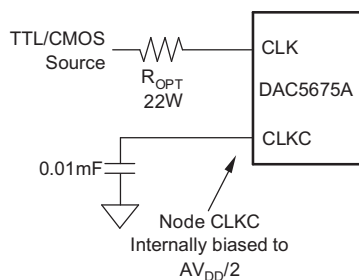

Copyright © 2016, Texas Instruments Incorporated

Figure 19. Driving the DAC5675A with a Single-Ended TTL/CMOS Clock Source

## Feature Description (continued)

### 8.3.3 Supply Inputs

The DAC5675A comprises separate analog and digital supplies, that is,  $AV_{DD}$  and  $DV_{DD}$ , respectively. These supply inputs can be set independently from 3.6V down to 3.15V.

### 8.3.4 DAC Transfer Function

The DAC5675A has a current sink output. The current flow through IOUT1 and IOUT2 is controlled by D[13:0]A and D[13:0]B. For ease of use, we denote D[13:0] as the logical bit equivalent of D[13:0]A and its complement D[13:0]B. The DAC5675A supports straight binary coding with D13 being the MSB and D0 the LSB. Full-scale current flows through IOUT2 when all D[13:0] inputs are set high and through IOUT1 when all D[13:0] inputs are set low. The relationship between IOUT1 and IOUT2 can be expressed as [Equation 1](#):

$$IOUT1 = IO_{(FS)} - IOUT2 \quad (1)$$

$IO_{(FS)}$  is the full-scale output current sink (2mA to 20mA). Since the output stage is a current sink, the current can only flow from  $AV_{DD}$  through the load resistors  $R_L$  into the IOUT1 and IOUT2 pins.

The output current flow in each pin driving a resistive load can be expressed as shown in [Figure 20](#), as well as in [Equation 2](#) and [Equation 3](#).

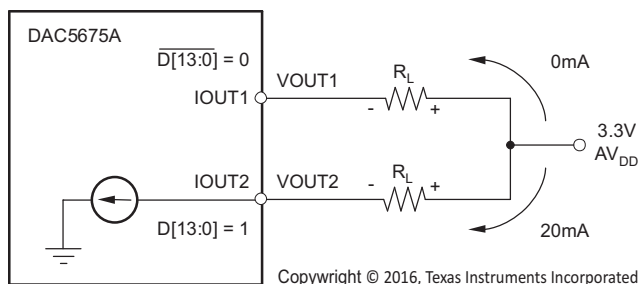

**Figure 20. Relationship Between D[13:0], IOUT1 and IOUT2**

$$IOUT1 = \frac{IO_{(FS)} \times (16383 - \text{CODE})}{16384} \quad (2)$$

$$IOUT2 = \frac{IO_{(FS)} \times \text{CODE}}{16384} \quad (3)$$

where CODE is the decimal representation of the DAC input word. This would translate into single-ended voltages at IOUT1 and IOUT2, as shown in [Equation 4](#) and [Equation 5](#):

$$VOUT1 = AVDD - IOUT1 \times R_L \quad (4)$$

$$VOUT2 = AVDD - IOUT2 \times R_L \quad (5)$$

Assuming that D[13:0] = 1 and the  $R_L$  is 50Ω, the differential voltage between pins IOUT1 and IOUT2 can be expressed as shown in [Equation 6](#) through [Equation 8](#):

$$VOUT1 = 3.3 \text{ V} - 0 \text{ mA} \times 50 = 3.3 \text{ V} \quad (6)$$

$$VOUT2 = AVDD - 20 \text{ mA} \times 50 = 2.3 \text{ V} \quad (7)$$

$$VDIFF = VOUT1 - VOUT2 = 1 \text{ V} \quad (8)$$

If D[13:0] = 0, then IOUT2 = 0mA and IOUT1 = 20mA and the differential voltage  $VDIFF = -1\text{V}$ .

The output currents and voltages in IOUT1 and IOUT2 are complementary. The voltage, when measured differentially, will be doubled compared to measuring each output individually. Care must be taken not to exceed the compliance voltages at the IOUT1 and IOUT2 pins in order to keep signal distortion low.

### 8.3.5 Reference Operation

The DAC5675A has a bandgap reference and control amplifier for biasing the full-scale output current. The full-scale output current is set by applying an external resistor  $R_{BIAS}$ . The bias current  $I_{BIAS}$  through resistor  $R_{BIAS}$  is defined by the on-chip bandgap reference voltage and control amplifier. The full-scale output current equals 16 times this bias current. The full-scale output current  $IO_{(FS)}$  is thus expressed as [Equation 9](#):



### Feature Description (continued)

$$I_{O(FS)} = 16 \times I_{BIAS} = \frac{16 \times V_{EXTIO}}{R_{BIAS}} \tag{9}$$

where  $V_{EXTIO}$  is the voltage at terminal EXTIO. The bandgap reference voltage delivers a stable voltage of 1.2 V. This reference can be overridden by applying an external voltage to terminal EXTIO. The bandgap reference can additionally be used for external reference operation. In such a case, an external buffer amplifier with high impedance input should be selected in order to limit the bandgap load current to less than 100 nA. The capacitor  $C_{EXT}$  may be omitted. Terminal EXTIO serves as either an input or output node. The full-scale output current is adjustable from 20mA down to 2mA by varying resistor  $R_{BIAS}$ .

#### 8.3.6 Analog Current Outputs

Figure 21 shows a simplified schematic of the current sink array output with corresponding switches. Differential NPN switches direct the current of each individual NPN current sink to either the positive output node IOUT1 or its complementary negative output node IOUT2. D[13:0] controls the S(N)C current switches and D[13:0] controls the S(N) current switches, as explained in the previous **DAC Transfer Function** section (see Figure 20). The output impedance is determined by the stack of the current sinks and differential switches, and is > 300kΩ in parallel with an output capacitance of 5pF.

The external output resistors are referred to the positive supply  $AV_{DD}$ .

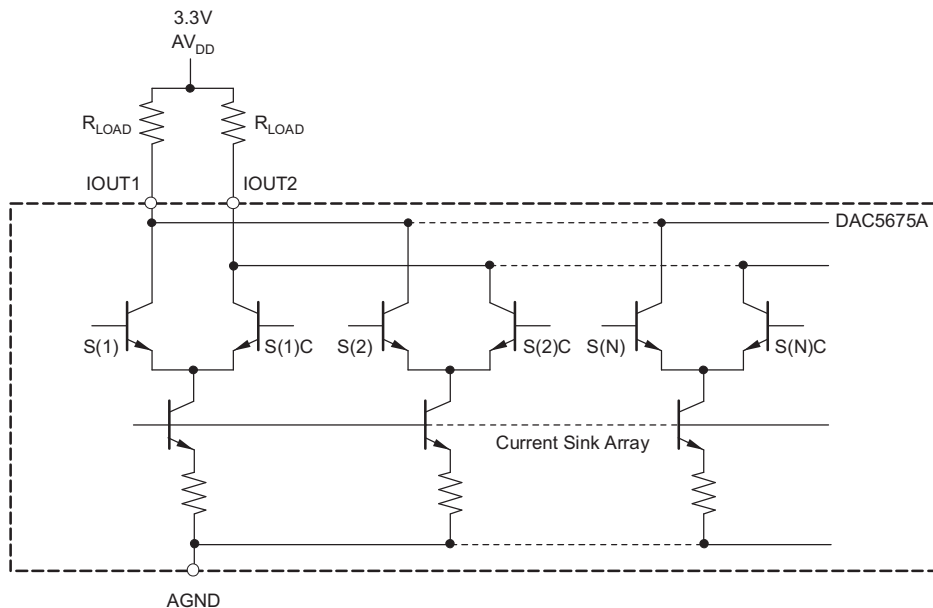

Copyright © 2016, Texas Instruments Incorporated

Figure 21. Equivalent Analog Current Output

The DAC5675A can easily be configured to drive a doubly-terminated 50Ω cable using a properly selected transformer. Figure 22 and Figure 23 show the 1:1 and 4:1 impedance ratio configuration, respectively. These configurations provide maximum rejection of common-mode noise sources and even-order distortion components, thereby doubling the power of the DAC to the output. The center tap on the primary side of the transformer is terminated to  $AV_{DD}$ , enabling a dc current flow for both IOUT1 and IOUT2. Note that the ac performance of the DAC5675A is optimum and specified using a 1:1 differential transformer-coupled output.

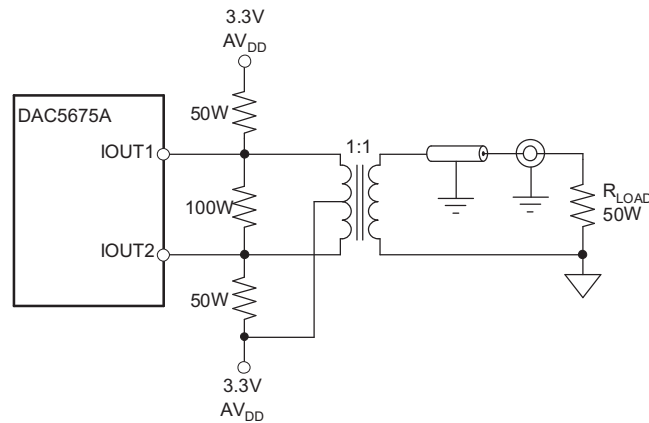
**Feature Description (continued)**

Copyright © 2016, Texas Instruments Incorporated

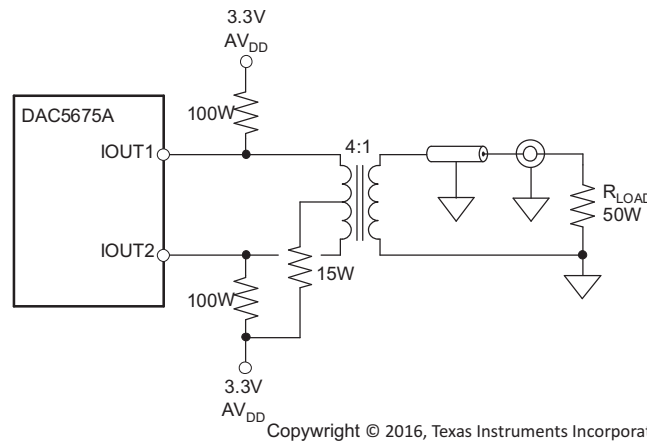
**Figure 22. Driving a Doubly-Terminated 50Ω Cable Using a 1:1 Impedance Ratio Transformer**

Copyright © 2016, Texas Instruments Incorporated

**Figure 23. Driving a Doubly-Terminated 50Ω Cable Using a 4:1 Impedance Ratio Transformer**

Figure 24(a) shows the typical differential output configuration with two external matched resistor loads. The nominal resistor load of 25 Ω gives a differential output swing of 1V<sub>PP</sub> (0.5–V<sub>PP</sub> single-ended) when applying a 20 mA full-scale output current. The output impedance of the DAC5675A slightly depends on the output voltage at nodes IOUT1 and IOUT2. Consequently, for optimum dc-integral nonlinearity, the configuration of Figure 24(b) should be chosen. In this current/voltage (I-V) configuration, terminal IOUT1 is kept at AV<sub>DD</sub> by the inverting operational amplifier. The complementary output should be connected to AV<sub>DD</sub> to provide a dc-current path for the current sources switched to IOUT1. The amplifier maximum output swing and the full-scale output current of the DAC determine the value of the feedback resistor (R<sub>FB</sub>). The capacitor (C<sub>FB</sub>) filters the steep edges of the DAC5675A current output, thereby reducing the operational amplifier slew-rate requirements. In this configuration, the op amp should operate at a supply voltage higher than the resistor output reference voltage AV<sub>DD</sub> as a result of its positive and negative output swing around AV<sub>DD</sub>. Node IOUT1 should be selected if a single-ended unipolar output is desired.

**Feature Description (continued)**

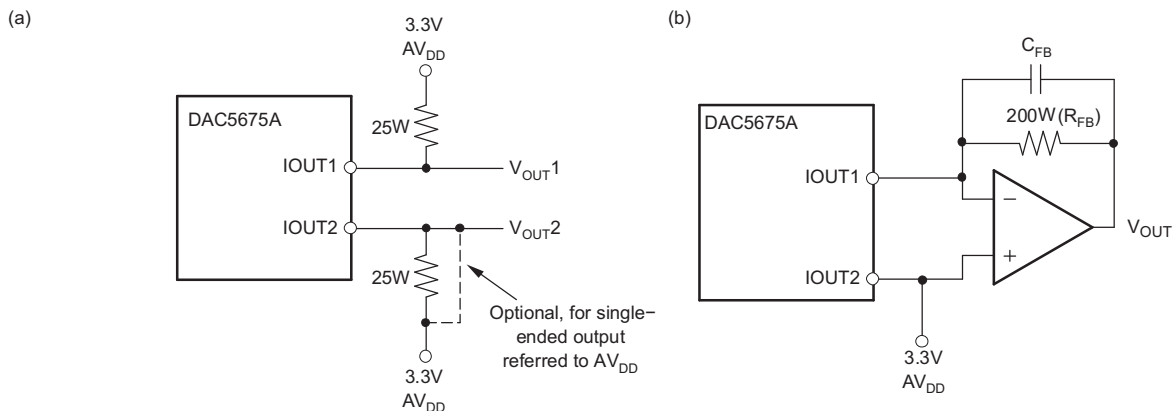

Copyright © 2016, Texas Instruments Incorporated

**Figure 24. Output Configurations**

**8.4 Device Functional Modes**

**8.4.1 Sleep Mode**

The DAC5675A features a power-down mode that turns off the output current and reduces the supply current to approximately 6mA. The power-down mode is activated by applying a logic level 1 to the SLEEP pin pulled down internally.

## 9 Application and Implementation

### NOTE

Information in the following applications sections is not part of the TI component specification, and TI does not warrant its accuracy or completeness. TI's customers are responsible for determining suitability of components for their purposes. Customers should validate and test their design implementation to confirm system functionality.

### 9.1 Application Information

Figure 25 shows a simplified block diagram of the current steering DAC5675A. The DAC5675A consists of a segmented array of NPN-transistor current sinks, capable of delivering a full-scale output current up to 20 mA. Differential current switches direct the current of each current sink to either one of the complementary output nodes IOUT1 or IOUT2. The complementary current output enables differential operation, canceling out common-mode noise sources (digital feed-through, on-chip and PCB noise), dc offsets, and even-order distortion components, and doubling signal output power.

The full-scale output current is set using an external resistor ( $R_{BIAS}$ ) in combination with an on-chip bandgap voltage reference source (1.2 V) and control amplifier. The current ( $I_{BIAS}$ ) through resistor  $R_{BIAS}$  is mirrored internally to provide a full-scale output current equal to 16 times  $I_{BIAS}$ . The full-scale current is adjustable from 20 mA down to 2 mA by using the appropriate bias resistor value.

### 9.2 Typical Application

A typical application for the DAC5675a is as dual or single carrier transmitter. The DAC is provided with some input digital baseband signal and it outputs an analog carrier.

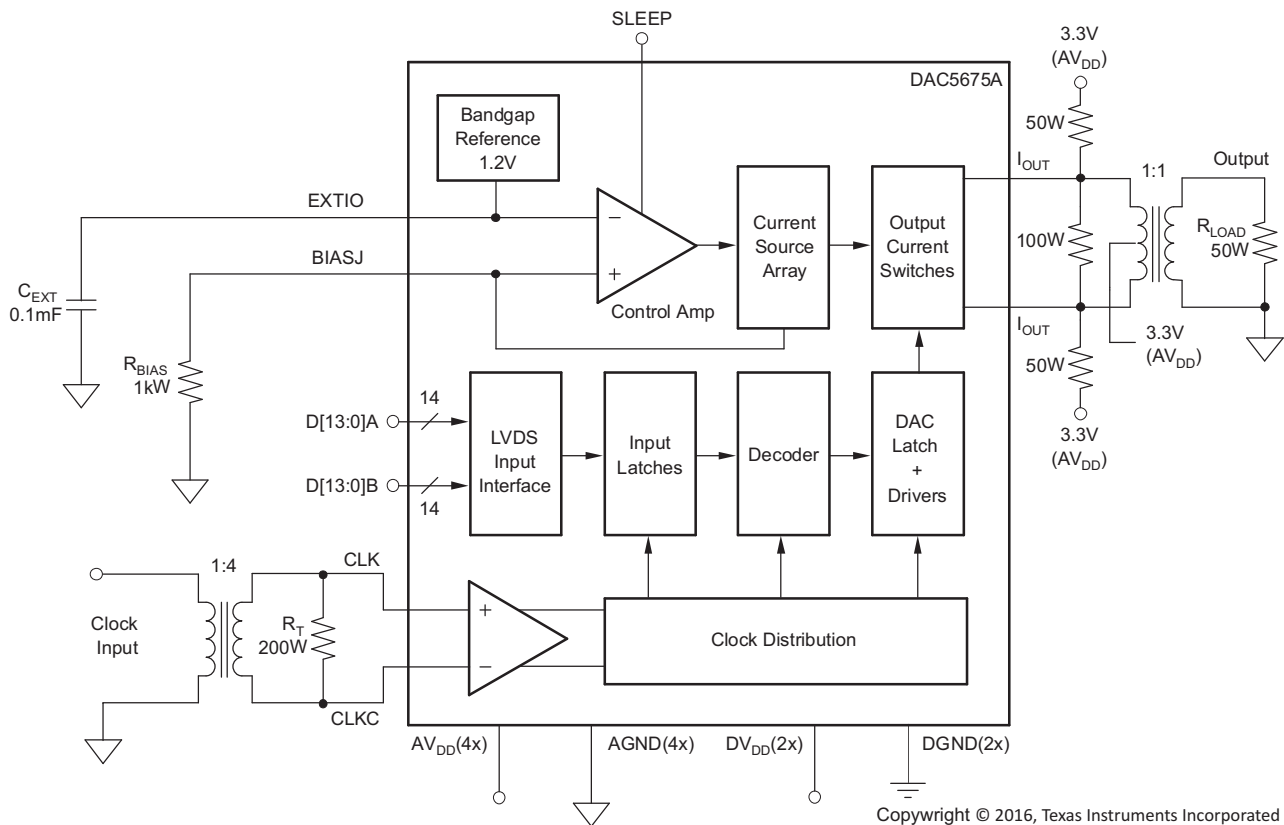

**Figure 25. Application Schematic**

## Typical Application (continued)

### 9.2.1 Design Requirements

The requirements for this design were to generate a 2-carrier WCDMA signal at an intermediate frequency of 92.16 MHz. The ACPR needs to be better than 65 dBc. For this design example use the parameters shown in [Table 1](#).

Table 1. Design Parameters

PARAMETER	VALUE
Clock rate	368.64 MHz
Input data	2C WCDMA with IF frequency at 92.16MHz
$V_{CC} / V_{AA}$	3.3 V

### 9.2.2 Detailed Design Procedure

The 2-carrier signal with an intermediate frequency of 92.16 MHz must be created in the digital processor at a sample rate of 368.64 Msp/s for DAC. These 14 bit samples are placed on the 14b LVDS input port of the DAC.

A differential DAC clock must be generated from a clock source at 368.64 MHz. This must be provided to the CLKIN pins of the DAC.

The IOUOTA and IOUOTB differential connections must be connected to a transformer to provide a single ended output. A typical 1:1 impedance transformer is used on the device EVM. The DAC5675AEVM ([SLAU080](#)) provides a good reference for this design example.

### 9.2.3 Application Curves

This spectrum analyzer plot shows the ACPR for the transformer output 2-carrier signal with intermediate frequency of 92.16 MHz. The results meet the system requirements for a minimum of 65 dBc ACPR.

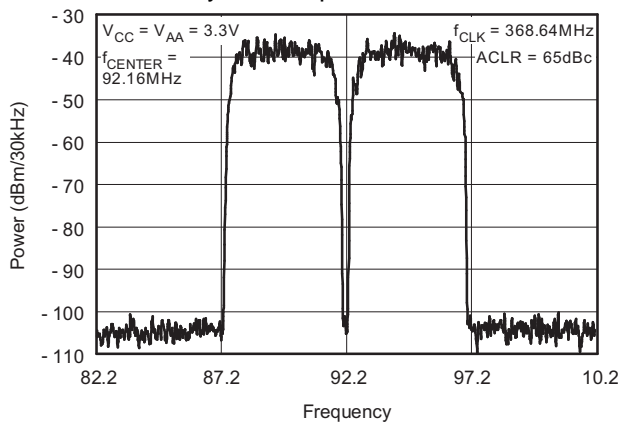

Figure 26. W-CDMA TM1 Dual Carrier Power vs Frequency

## 10 Power Supply Recommendations

It is recommended that the device be powered with the nominal supply voltages as indicated in the [Recommended Operating Conditions](#).

In most instances the best performance is achieved with LDO supplies. However the supplies may be driven with direct outputs from a DC-DC switcher as long as the noise performance of the switcher is acceptable.

## 11 Layout

### 11.1 Layout Guidelines

The DAC5675 EVM layout should be used as a reference for the layout to obtain the best performance. A sample layout is shown in Figure 27. Some important layout recommendations are:

- Use a single ground plane. Keep the digital and analog signals on distinct separate sections of the board. This may be virtually divided down the middle of the device package when doing placement and layout.
- Keep the analog outputs as far away from the switching clocks and digital signals as possible. This will keep coupling from the digital circuits to the analog outputs to a minimum.
- Decoupling caps should be kept close to the power pins of the device.

### 11.2 Layout Example

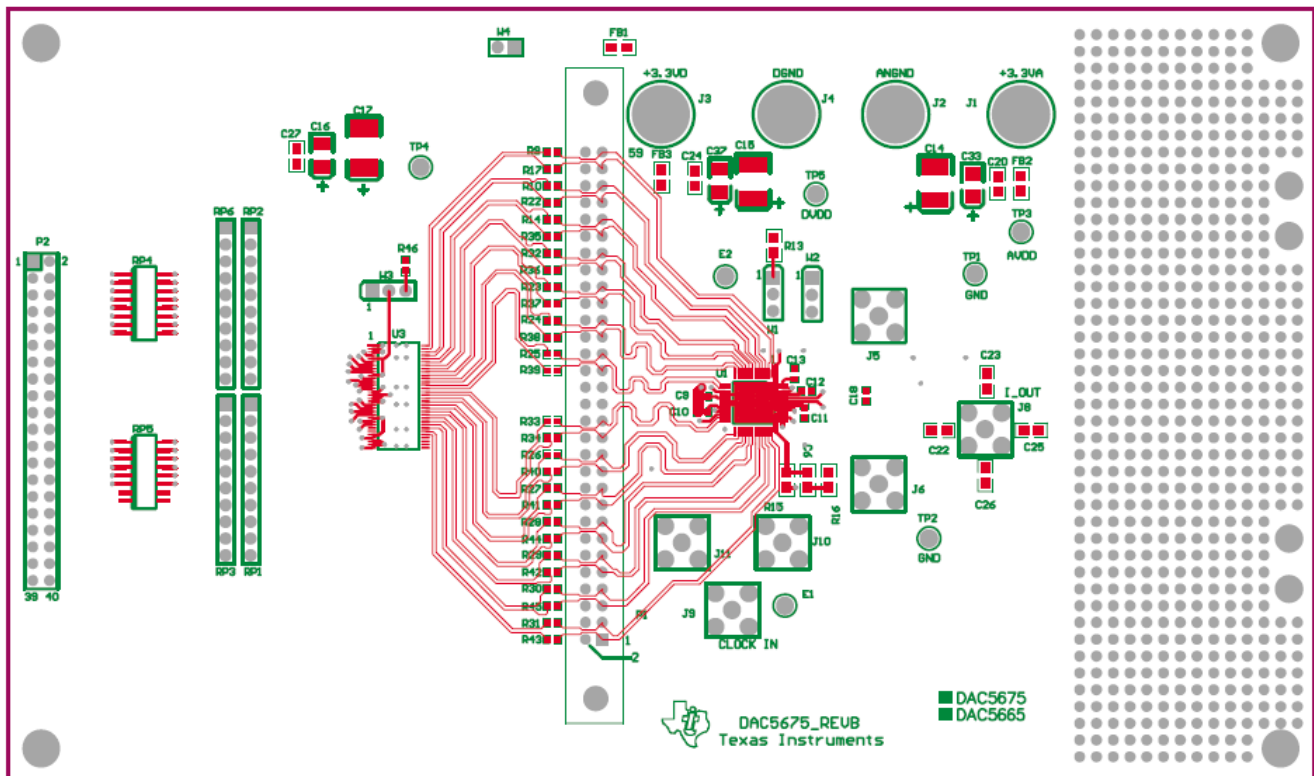
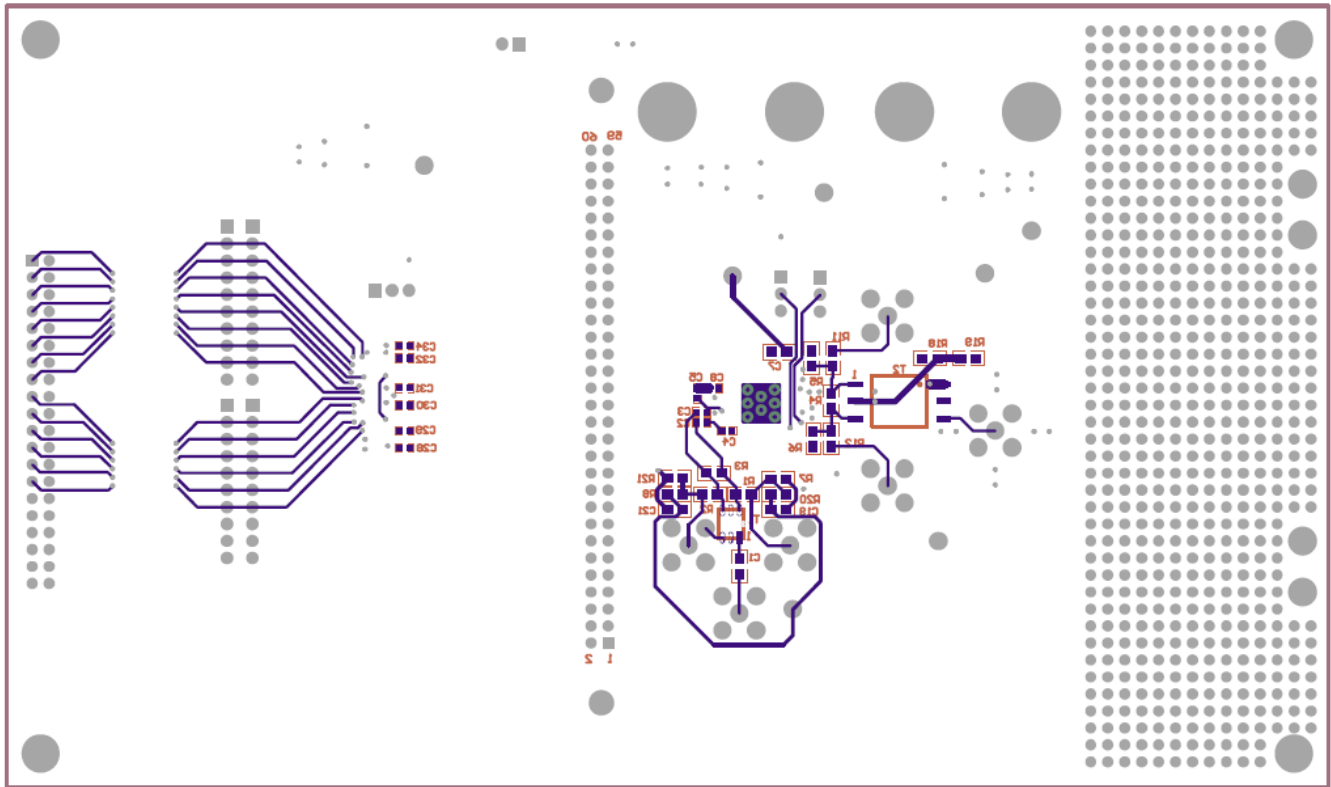

Figure 27. Top Layer of DAC5675A EVM Layout

**Layout Example (continued)**



**Figure 28. Bottom Layer of DAC5675A EVM Layout**

## 12 Device and Documentation Support

### 12.1 Receiving Notification of Documentation Updates

To receive notification of documentation updates — go to the product folder for your device on ti.com. In the upper right-hand corner, click the *Alert me* button to register and receive a weekly digest of product information that has changed (if any). For change details, check the revision history of any revised document.

### 12.2 Community Resources

The following links connect to TI community resources. Linked contents are provided "AS IS" by the respective contributors. They do not constitute TI specifications and do not necessarily reflect TI's views; see TI's [Terms of Use](#).

**TI E2E™ Online Community** *TI's Engineer-to-Engineer (E2E) Community*. Created to foster collaboration among engineers. At e2e.ti.com, you can ask questions, share knowledge, explore ideas and help solve problems with fellow engineers.

**Design Support** *TI's Design Support* Quickly find helpful E2E forums along with design support tools and contact information for technical support.

### 12.3 Trademarks

PowerPad, E2E are trademarks of Texas Instruments.  
All other trademarks are the property of their respective owners.

### 12.4 Electrostatic Discharge Caution



These devices have limited built-in ESD protection. The leads should be shorted together or the device placed in conductive foam during storage or handling to prevent electrostatic damage to the MOS gates.

### 12.5 Glossary

[SLYZ022](#) — *TI Glossary*.

This glossary lists and explains terms, acronyms, and definitions.

### 12.6 Device Nomenclature

#### 12.6.1 Definitions of Specifications and Terminology

**Gain error** is defined as the percentage error in the ratio between the measured full-scale output current and the value of  $16 \times V_{(EXTIO)}/R_{BIAS}$ . A  $V_{(EXTIO)}$  of 1.25V is used to measure the gain error with an external reference voltage applied. With an internal reference, this error includes the deviation of  $V_{(EXTIO)}$  (internal bandgap reference voltage) from the typical value of 1.25V.

**Offset error** is defined as the percentage error in the ratio of the differential output current (IOUT1–IOUT2) and the half of the full-scale output current for input code 8192.

**THD** is the ratio of the rms sum of the first six harmonic components to the rms value of the fundamental output signal.

**SNR** is the ratio of the rms value of the fundamental output signal to the rms sum of all other spectral components below the Nyquist frequency, including noise, but excluding the first six harmonics and dc.

**SINAD** is the ratio of the rms value of the fundamental output signal to the rms sum of all other spectral components below the Nyquist frequency, including noise and harmonics, but excluding dc.

**ACPR** or adjacent channel power ratio is defined for a 3.84Mcps 3GPP W-CDMA input signal measured in a 3.84MHz bandwidth at a 5MHz offset from the carrier with a 12dB peak-to-average ratio.

**APSSR** or analog power supply ratio is the percentage variation of full-scale output current versus a 5% variation of the analog power supply  $AV_{DD}$  from the nominal. This is a dc measurement.

**DPSSR** or digital power supply ratio is the percentage variation of full-scale output current versus a 5% variation of the digital power supply  $DV_{DD}$  from the nominal. This is a dc measurement.



### **13 Mechanical, Packaging, and Orderable Information**

The following pages include mechanical, packaging, and orderable information. This information is the most current data available for the designated devices. This data is subject to change without notice and revision of this document. For browser-based versions of this data sheet, refer to the left-hand navigation.

**PACKAGING INFORMATION**

Orderable Device	Status (1)	Package Type	Package Drawing	Pins	Package Qty	Eco Plan (2)	Lead/Ball Finish (6)	MSL Peak Temp (3)	Op Temp (°C)	Device Marking (4/5)	Samples
DAC5675AIPHP	ACTIVE	HTQFP	PHP	48	250	Green (RoHS & no Sb/Br)	CU NIPDAU	Level-3-260C-168 HR	-40 to 85	DAC5675AI	Samples

(1) The marketing status values are defined as follows:

**ACTIVE:** Product device recommended for new designs.

**LIFEBUY:** TI has announced that the device will be discontinued, and a lifetime-buy period is in effect.

**NRND:** Not recommended for new designs. Device is in production to support existing customers, but TI does not recommend using this part in a new design.

**PREVIEW:** Device has been announced but is not in production. Samples may or may not be available.

**OBSOLETE:** TI has discontinued the production of the device.

(2) **RoHS:** TI defines "RoHS" to mean semiconductor products that are compliant with the current EU RoHS requirements for all 10 RoHS substances, including the requirement that RoHS substance do not exceed 0.1% by weight in homogeneous materials. Where designed to be soldered at high temperatures, "RoHS" products are suitable for use in specified lead-free processes. TI may reference these types of products as "Pb-Free".

**RoHS Exempt:** TI defines "RoHS Exempt" to mean products that contain lead but are compliant with EU RoHS pursuant to a specific EU RoHS exemption.

**Green:** TI defines "Green" to mean the content of Chlorine (Cl) and Bromine (Br) based flame retardants meet JS709B low halogen requirements of <=1000ppm threshold. Antimony trioxide based flame retardants must also meet the <=1000ppm threshold requirement.

(3) MSL, Peak Temp. - The Moisture Sensitivity Level rating according to the JEDEC industry standard classifications, and peak solder temperature.

(4) There may be additional marking, which relates to the logo, the lot trace code information, or the environmental category on the device.

(5) Multiple Device Markings will be inside parentheses. Only one Device Marking contained in parentheses and separated by a "~" will appear on a device. If a line is indented then it is a continuation of the previous line and the two combined represent the entire Device Marking for that device.

(6) Lead/Ball Finish - Orderable Devices may have multiple material finish options. Finish options are separated by a vertical ruled line. Lead/Ball Finish values may wrap to two lines if the finish value exceeds the maximum column width.

**Important Information and Disclaimer:**The information provided on this page represents TI's knowledge and belief as of the date that it is provided. TI bases its knowledge and belief on information provided by third parties, and makes no representation or warranty as to the accuracy of such information. Efforts are underway to better integrate information from third parties. TI has taken and continues to take reasonable steps to provide representative and accurate information but may not have conducted destructive testing or chemical analysis on incoming materials and chemicals. TI and TI suppliers consider certain information to be proprietary, and thus CAS numbers and other limited information may not be available for release.

In no event shall TI's liability arising out of such information exceed the total purchase price of the TI part(s) at issue in this document sold by TI to Customer on an annual basis.

**OTHER QUALIFIED VERSIONS OF DAC5675A :**

- Space: [DAC5675A-SP](#)

NOTE: Qualified Version Definitions:

- Space - Radiation tolerant, ceramic packaging and qualified for use in Space-based application

PHP (S-PQFP-G48)

PowerPAD™ PLASTIC QUAD FLATPACK

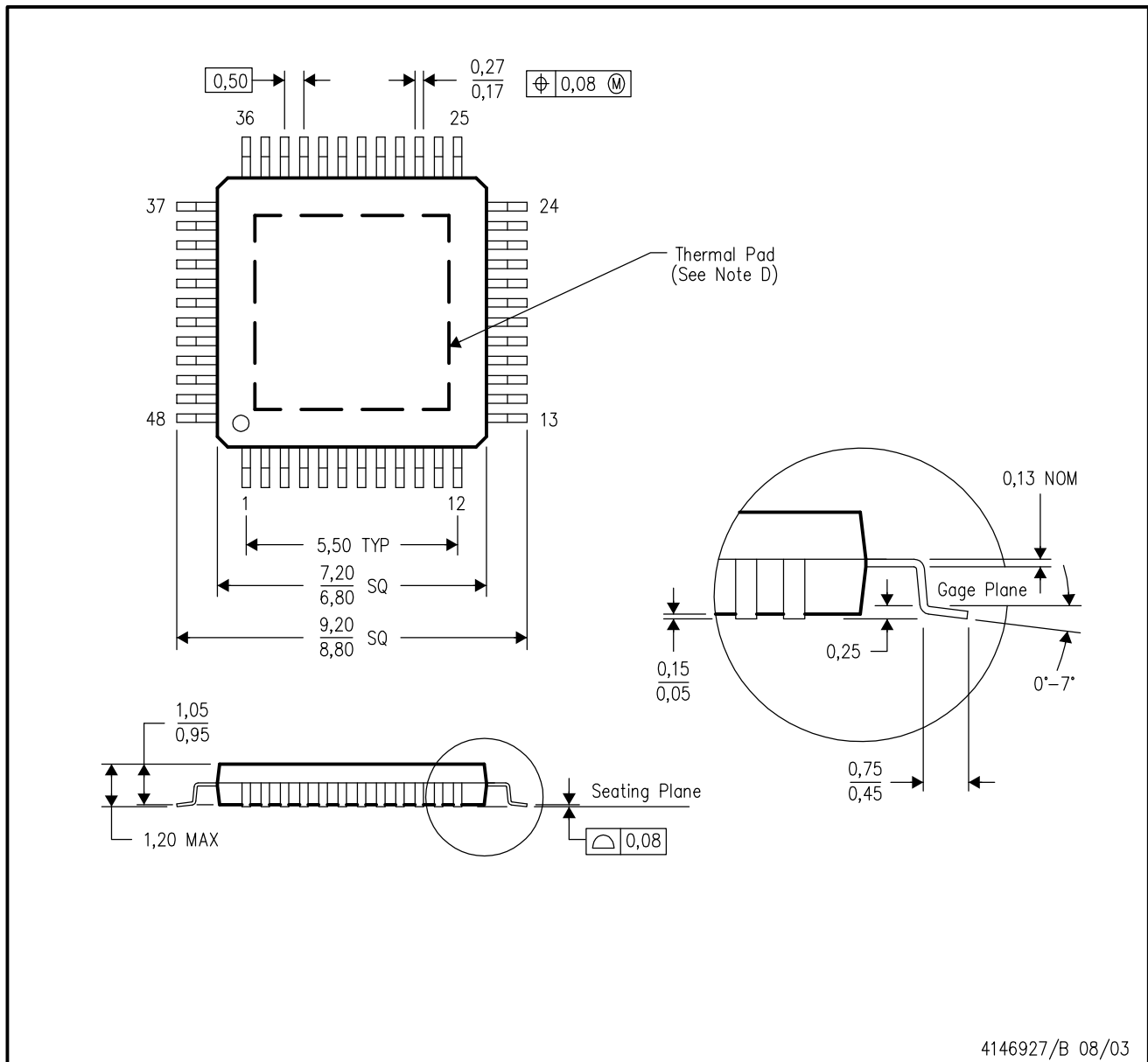

4146927/B 08/03

- NOTES:
- A. All linear dimensions are in millimeters.
  - B. This drawing is subject to change without notice.
  - C. Body dimensions do not include mold flash or protrusion
  - D. This package is designed to be soldered to a thermal pad on the board. Refer to Technical Brief, PowerPad Thermally Enhanced Package, Texas Instruments Literature No. SLMA002 for information regarding recommended board layout. This document is available at [www.ti.com](http://www.ti.com) <<http://www.ti.com>>.
  - E. Falls within JEDEC MS-026

PowerPAD is a trademark of Texas Instruments.

# THERMAL PAD MECHANICAL DATA

PHP (S-PQFP-G48)

PowerPAD™ PLASTIC QUAD FLATPACK

## THERMAL INFORMATION

This PowerPAD™ package incorporates an exposed thermal pad that is designed to be attached to a printed circuit board (PCB). The thermal pad must be soldered directly to the PCB. After soldering, the PCB can be used as a heatsink. In addition, through the use of thermal vias, the thermal pad can be attached directly to the appropriate copper plane shown in the electrical schematic for the device, or alternatively, can be attached to a special heatsink structure designed into the PCB. This design optimizes the heat transfer from the integrated circuit (IC).

For additional information on the PowerPAD package and how to take advantage of its heat dissipating abilities, refer to Technical Brief, PowerPAD Thermally Enhanced Package, Texas Instruments Literature No. SLMA002 and Application Brief, PowerPAD Made Easy, Texas Instruments Literature No. SLMA004. Both documents are available at [www.ti.com](http://www.ti.com).

The exposed thermal pad dimensions for this package are shown in the following illustration.

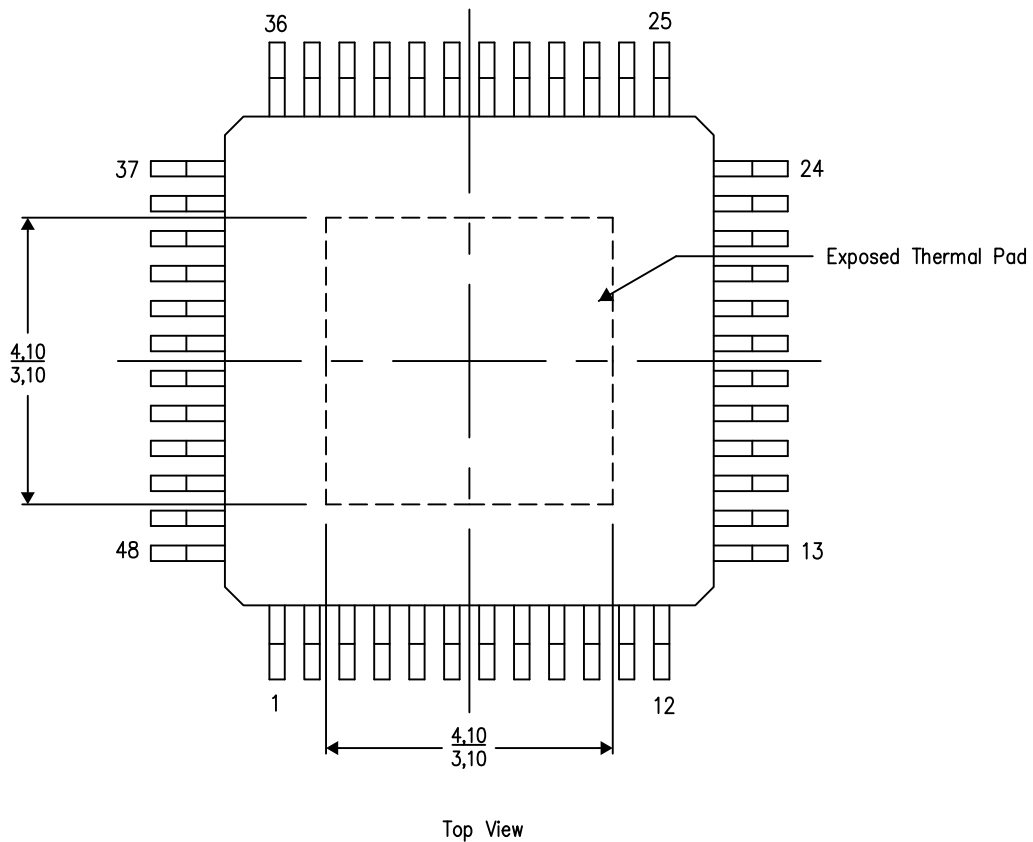

Exposed Thermal Pad Dimensions

4206329-3/P 03/15

NOTE: A. All linear dimensions are in millimeters

PowerPAD is a trademark of Texas Instruments

PHP (S-PQFP-G48)

PowerPAD™ PLASTIC QUAD FLATPACK

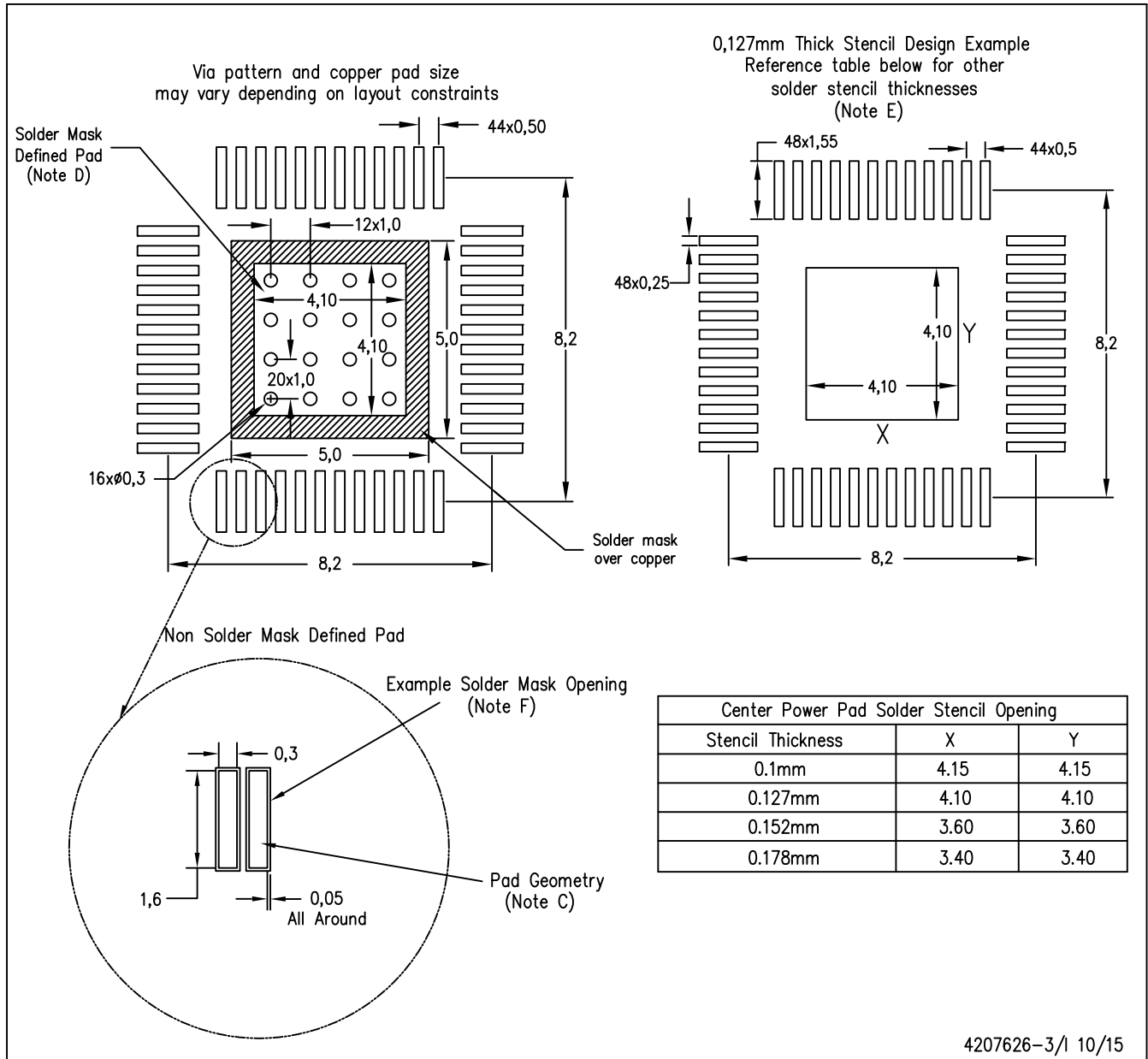

- NOTES:
- A. All linear dimensions are in millimeters.
  - B. This drawing is subject to change without notice.
  - C. Publication IPC-7351 is recommended for alternate designs.
  - D. This package is designed to be soldered to a thermal pad on the board. Refer to Technical Brief, PowerPAD Thermally Enhanced Package, Texas Instruments Literature No. SLMA002, SLMA004, and also the Product Data Sheets for specific thermal information, via requirements, and recommended board layout. These documents are available at [www.ti.com](http://www.ti.com) <<http://www.ti.com>>.
  - E. Laser cutting apertures with trapezoidal walls and also rounding corners will offer better paste release. Customers should contact their board assembly site for stencil design recommendations. Refer to IPC 7525 for stencil design considerations.
  - F. Customers should contact their board fabrication site for recommended solder mask tolerances and via tenting options for vias placed in the thermal pad.

PowerPAD is a trademark of Texas Instruments

## IMPORTANT NOTICE AND DISCLAIMER

TI PROVIDES TECHNICAL AND RELIABILITY DATA (INCLUDING DATASHEETS), DESIGN RESOURCES (INCLUDING REFERENCE DESIGNS), APPLICATION OR OTHER DESIGN ADVICE, WEB TOOLS, SAFETY INFORMATION, AND OTHER RESOURCES "AS IS" AND WITH ALL FAULTS, AND DISCLAIMS ALL WARRANTIES, EXPRESS AND IMPLIED, INCLUDING WITHOUT LIMITATION ANY IMPLIED WARRANTIES OF MERCHANTABILITY, FITNESS FOR A PARTICULAR PURPOSE OR NON-INFRINGEMENT OF THIRD PARTY INTELLECTUAL PROPERTY RIGHTS.

These resources are intended for skilled developers designing with TI products. You are solely responsible for (1) selecting the appropriate TI products for your application, (2) designing, validating and testing your application, and (3) ensuring your application meets applicable standards, and any other safety, security, or other requirements. These resources are subject to change without notice. TI grants you permission to use these resources only for development of an application that uses the TI products described in the resource. Other reproduction and display of these resources is prohibited. No license is granted to any other TI intellectual property right or to any third party intellectual property right. TI disclaims responsibility for, and you will fully indemnify TI and its representatives against, any claims, damages, costs, losses, and liabilities arising out of your use of these resources.

TI's products are provided subject to TI's Terms of Sale ([www.ti.com/legal/termsofsale.html](http://www.ti.com/legal/termsofsale.html)) or other applicable terms available either on [ti.com](http://ti.com) or provided in conjunction with such TI products. TI's provision of these resources does not expand or otherwise alter TI's applicable warranties or warranty disclaimers for TI products.

Mailing Address: Texas Instruments, Post Office Box 655303, Dallas, Texas 75265  
Copyright © 2019, Texas Instruments Incorporated