

SINGLE-ENDED, ANALOG-INPUT 24-BIT, 96-kHz STEREO A/D CONVERTER

Check for Samples: [PCM1808-Q1](#)

FEATURES

- Qualified for Automotive Applications
- 24-Bit Delta-Sigma Stereo A/D Converter
- Single-Ended Voltage Input: 3 Vp-p
- High Performance:
 - THD + N: –93 dB (Typical)
 - SNR: 99 dB (Typical)
 - Dynamic Range: 99 dB (Typical)
- Oversampling Decimation Filter:
 - Oversampling Frequency: $\times 64$
 - Pass-Band Ripple: ± 0.05 dB
 - Stop-Band Attenuation: –65 dB
 - On-Chip High-Pass Filter: 0.91 Hz (48 kHz)
- Flexible PCM Audio Interface
 - Master/Slave Mode Selectable
 - Data Formats: 24-Bit I²S, 24-Bit Left-Justified
- Power Down and Reset by Halting System Clock
- Analog Antialias LPF Included
- Sampling Rate: 8 kHz–96 kHz
- System Clock: 256 f_S, 384 f_S, 512 f_S
- Dual Power Supplies:
 - 5-V for Analog
 - 3.3-V for Digital

- Package: 14-Pin TSSOP

DESCRIPTION

The PCM1808-Q1 is high-performance, low-cost, single-chip, stereo analog-to-digital converter with single-ended analog voltage input. The PCM1808-Q1 uses a delta-sigma modulator with 64-times oversampling and includes a digital decimation filter and high-pass filter that removes the dc component of the input signal. For various applications, the PCM1808-Q1 supports master and slave mode and two data formats in serial audio interface.

The PCM1808-Q1 supports the power-down and reset function by means of halting the system clock.

The PCM1808-Q1 is suitable for wide variety of cost-sensitive consumer applications where good performance and operation with a 5-V analog supply and 3.3-V digital supply is required. The PCM1808-Q1 is fabricated using a highly advanced CMOS process and is available in a small, 14-pin TSSOP package.



Please be aware that an important notice concerning availability, standard warranty, and use in critical applications of Texas Instruments semiconductor products and disclaimers thereto appears at the end of this data sheet.

System Two, Audio Precision are trademarks of Audio Precision, Inc.
All other trademarks are the property of their respective owners.



This integrated circuit can be damaged by ESD. Texas Instruments recommends that all integrated circuits be handled with appropriate precautions. Failure to observe proper handling and installation procedures can cause damage.

ESD damage can range from subtle performance degradation to complete device failure. Precision integrated circuits may be more susceptible to damage because very small parametric changes could cause the device not to meet its published specifications.

ABSOLUTE MAXIMUM RATINGS

over operating free-air temperature range (unless otherwise noted) ⁽¹⁾

	PCM1808-Q1
Analog supply voltage, V_{CC}	–0.3 V to 6.5 V
Digital supply voltage, V_{DD}	–0.3 V to 4 V
Ground voltage differences, AGND, DGND	±0.1 V
Digital input voltage, LRCK, BCK, DOUT	–0.3 V to ($V_{DD} + 0.3$ V) < 4 V
Digital input voltage, SCKI, MD0, MD1, FMT	–0.3 V to 6.5 V
Analog input voltage, V_{INL} , V_{INR} , V_{REF}	–0.3 V to ($V_{CC} + 0.3$ V) < 6.5 V
Input current (any pins except supplies)	±10 mA
Ambient temperature under bias, T_A	–40°C to 125°C
Storage temperature, T_{stg}	–55°C to 150°C
Junction temperature, T_J	150°C
Lead temperature (soldering)	260°C, 5 s
Package temperature (reflow, peak)	260°C

(1) Stresses beyond those listed under *Absolute Maximum Ratings* may cause permanent damage to the device. These are stress ratings only, and functional operation of the device at these or any other conditions beyond those indicated under *Recommended Operating Conditions* is not implied. Exposure to absolute-maximum-rated conditions for extended periods may affect device reliability.

RECOMMENDED OPERATING CONDITIONS

over operating free-air temperature range (unless otherwise noted)

		MIN	NOM	MAX	UNIT
Analog supply voltage, V_{CC}		4.5	5	5.5	V
Digital supply voltage, V_{DD}		2.7	3.3	3.6	V
Analog input voltage, full scale (–0 dB)	$V_{CC} = 5$ V	2.93	3	3.23	Vp-p
Digital input logic family		TTL compatible			
Digital input clock frequency, system clock		2.048		49.152	MHz
Digital input clock frequency, sampling clock		8		96	kHz
Digital output load capacitance				20	pF
Operating free-air temperature, T_A		–40		125	°C

ELECTRICAL CHARACTERISTICS

All specifications at $T_A = 25^\circ\text{C}$, $V_{CC} = 5\text{ V}$, $V_{DD} = 3.3\text{ V}$, master mode, $f_S = 48\text{ kHz}$, system clock = $512 f_S$, 24-bit data, unless otherwise noted

PARAMETER		TEST CONDITIONS		MIN	TYP	MAX	UNIT	
Resolution				24			Bits	
DATA FORMAT								
Audio data interface format				I ² S, left-justified				
Audio data bit length				24			Bits	
Audio data format				MSB-first, 2s complement				
f_S	Sampling frequency			8	48	96	kHz	
System clock frequency, $-40^\circ\text{C} \leq T_A \leq 125^\circ\text{C}^{(1)}$		256 f_S		2.048	12.288	24.576	MHz	
		384 f_S		3.072	18.432	36.864		
		512 f_S		4.096	24.576	49.152		
INPUT LOGIC								
$V_{IH}^{(2)}$	Input logic level, $-40^\circ\text{C} \leq T_A \leq 125^\circ\text{C}^{(3)}$			2			VDC	
$V_{IL}^{(2)}$				0	V_{DD}			
$V_{IH}^{(4) (5)}$				2	5.5			
$V_{IL}^{(4) (5)}$				0	0.8			
$I_{IH}^{(4)}$	Input logic current	$V_{IN} = V_{DD}$				± 10	μA	
$I_{IL}^{(4)}$		$V_{IN} = 0\text{ V}$				± 10		
$I_{IH}^{(2) (5)}$		$V_{IN} = V_{DD}$		at 25°C		65		100
				$-40^\circ\text{C} \leq T_A \leq 125^\circ\text{C}$		65		150
$I_{IL}^{(2) (5)}$	$V_{IN} = 0\text{ V}$				± 10			
OUTPUT LOGIC								
$V_{OH}^{(6)}$	Output logic level ⁽³⁾	$I_{OUT} = -4\text{ mA}$		at 25°C		2.8	VDC	
				$-40^\circ\text{C} \leq T_A \leq 125^\circ\text{C}$		2.7		
$V_{OL}^{(6)}$		$I_{OUT} = 4\text{ mA}, -40^\circ\text{C} \leq T_A \leq 125^\circ\text{C}$				0.5		
DC ACCURACY, $-40^\circ\text{C} \leq T_A \leq 125^\circ\text{C}$								
Gain mismatch, channel-to-channel				± 1	± 3	% of FSR		
Gain error				± 3	± 6	% of FSR		
DYNAMIC PERFORMANCE ⁽⁷⁾								
THD + N	Total harmonic distortion + noise	$V_{IN} = -0.5\text{ dB}, f_S = 48\text{ kHz}$		at 25°C		-93	-87	dB
				$-40^\circ\text{C} \leq T_A \leq 125^\circ\text{C}$		-93	-85	
		$V_{IN} = -0.5\text{ dB}, f_S = 96\text{ kHz}^{(8)}$				-87		
		$V_{IN} = -60\text{ dB}, f_S = 48\text{ kHz}$				-37		
		$V_{IN} = -60\text{ dB}, f_S = 96\text{ kHz}^{(8)}$				-39		
Dynamic range		$f_S = 48\text{ kHz}, \text{A-weighted}$		at 25°C		95	99	dB
				$-40^\circ\text{C} \leq T_A \leq 125^\circ\text{C}$		93	99	
		$f_S = 96\text{ kHz}, \text{A-weighted}^{(8)}$				101		
S/N	Signal-to-noise ratio	$f_S = 48\text{ kHz}, \text{A-weighted}$		at 25°C		95	99	dB
				$-40^\circ\text{C} \leq T_A \leq 125^\circ\text{C}$		93	99	
		$f_S = 96\text{ kHz}, \text{A-weighted}^{(8)}$				101		

(1) 384 f_S where $f_S = 96\text{ kHz}$, and 512 where $f_S = 48\text{ kHz}$ and 96 kHz are functionally tested. Other options are specified by design.

(2) Pins 7, 8: LRCK, BCK (Schmitt-trigger input, with 50-k Ω typical pulldown resistor, in slave mode)

(3) Specified by design

(4) Pin 6: SCKI (Schmitt-trigger input, 5-V tolerant)

(5) Pins 10–12: MD0, MD1, FMT (Schmitt-trigger input, with 50-k Ω typical pulldown resistor, 5-V tolerant)

(6) Pins 7–9: LRCK, BCK (in master mode), DOUT

(7) Analog performance specifications are tested using a System Two™ audio measurement system by Audio Precision™ with 400-Hz HPF and 20-kHz LPF in RMS mode.

(8) $f_S = 96\text{ kHz}$, system clock = $256 f_S$.

ELECTRICAL CHARACTERISTICS (continued)

All specifications at $T_A = 25^\circ\text{C}$, $V_{CC} = 5\text{ V}$, $V_{DD} = 3.3\text{ V}$, master mode, $f_S = 48\text{ kHz}$, system clock = $512 f_S$, 24-bit data, unless otherwise noted

PARAMETER		TEST CONDITIONS	MIN	TYP	MAX	UNIT
Channel separation	$f_S = 48\text{ kHz}$	at 25°C	93	97		dB
		$-40^\circ\text{C} \leq T_A \leq 125^\circ\text{C}$	91	97		
	$f_S = 96\text{ kHz}^{(8)}$			91		
ANALOG INPUT						
Input voltage, $-40^\circ\text{C} \leq T_A \leq 125^\circ\text{C}$			$0.58 V_{CC}$	$0.6 V_{CC}$	$0.65 V_{CC}$	Vp-p
Center voltage input range, $-40^\circ\text{C} \leq T_A \leq 125^\circ\text{C}$			$0.2 V_{CC}$	$0.5 V_{CC}$	$0.8 V_{CC}$	V
Input impedance				60		k Ω
Antialiasing filter frequency response		-3 dB		1.3		MHz
DIGITAL FILTER PERFORMANCE, $-40^\circ\text{C} \leq T_A \leq 125^\circ\text{C}^{(3)}$						
Pass band					$0.454 f_S$	Hz
Stop band			$0.583 f_S$			Hz
Pass-band ripple					± 0.05	dB
Stop-band attenuation			-65			dB
Delay time				$17.4/f_S$		
HPF frequency response		-3 dB		$0.019 f_S/1000$		
POWER SUPPLY REQUIREMENTS						
V_{CC}	Voltage range, $-40^\circ\text{C} \leq T_A \leq 125^\circ\text{C}$		4.5	5	5.5	VDC
V_{DD}			2.7	3.3	3.6	
I_{CC}	Supply current ⁽⁹⁾	$f_S = 48\text{ kHz}, 96\text{ kHz}, -40^\circ\text{C} \leq T_A \leq 125^\circ\text{C}^{(10)}$		8.6	11	mA
		Powered down ⁽¹¹⁾		1		μA
I_{DD}	Supply current ⁽⁹⁾	$f_S = 48\text{ kHz}$	at 25°C	5.9	8	mA
			$-40^\circ\text{C} \leq T_A \leq 125^\circ\text{C}$	5.9	10	
		$f_S = 96\text{ kHz}^{(10)}$		10.2		mA
		Powered down ⁽¹¹⁾		150		μA
Power dissipation ⁽⁹⁾		$f_S = 48\text{ kHz}$		62	81	mW
		$f_S = 96\text{ kHz}^{(10)}$		77		
		Powered down ⁽¹¹⁾		500		μW
TEMPERATURE RANGE						
T_A	Operation temperature		-40		125	$^\circ\text{C}$
θ_{JA}	Thermal resistance			170		$^\circ\text{C/W}$

(9) Minimum load on LRCK (pin 7), BCK (pin 8), DOUT (pin 9)

(10) $f_S = 96\text{ kHz}$, system clock = $256 f_S$.

(11) Power-down and reset functions enabled by halting SCKI, BCK, LRCK.

PIN ASSIGNMENTS

PW PACKAGE
(TOP VIEW)

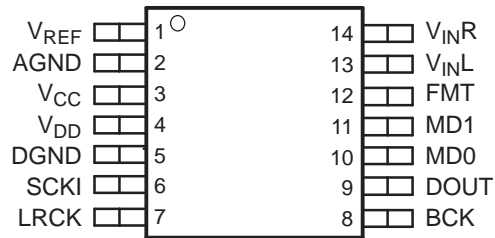

P0032-02

TERMINAL FUNCTIONS

TERMINAL NAME		PIN	I/O	DESCRIPTION
AGND	2	–	–	Analog GND
BCK	8	I/O	–	Audio data bit clock input/output ⁽¹⁾
DGND	5	–	–	Digital GND
DOUT	9	O	–	Audio data digital output
FMT	12	I	–	Audio interface format select ⁽²⁾
LRCK	7	I/O	–	Audio data latch enable input/output ⁽¹⁾
MD0	10	I	–	Audio interface mode select 0 ⁽²⁾
MD1	11	I	–	Audio interface mode select 1 ⁽²⁾
SCKI	6	I	–	System clock input; 256 f _S , 384 f _S or 512 f _S ⁽³⁾
V _{CC}	3	–	–	Analog power supply, 5-V
V _{DD}	4	–	–	Digital power supply, 3.3-V
V _{INL}	13	I	–	Analog input, L-channel
V _{INR}	14	I	–	Analog input, R-channel
V _{REF}	1	–	–	Reference voltage decoupling (= 0.5 V _{CC})

(1) Schmitt-trigger input with internal pulldown (50-kΩ, typical)

(2) Schmitt-trigger input with internal pulldown (50-kΩ, typical), 5-V tolerant

(3) Schmitt-trigger input, 5-V tolerant

Functional Block Diagram

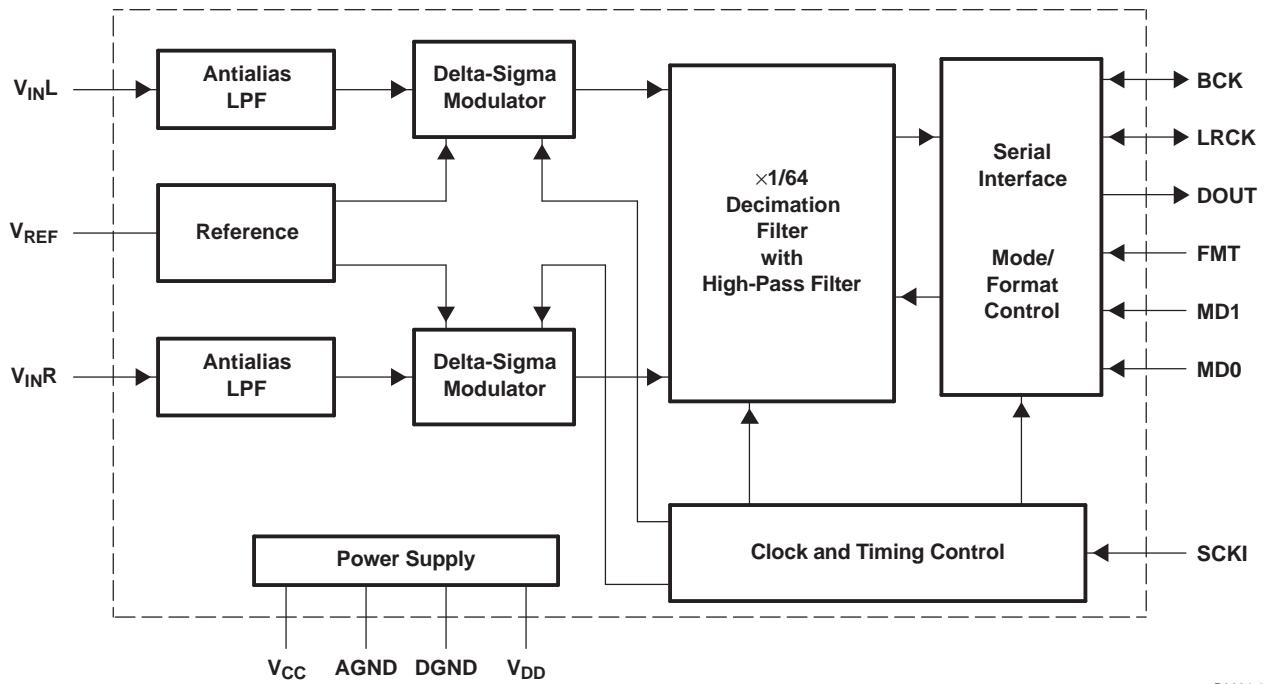

B0004-10

TYPICAL PERFORMANCE CURVES OF INTERNAL FILTERS

All specifications at $T_A = 25^\circ\text{C}$, $V_{CC} = 5\text{ V}$, $V_{DD} = 3.3\text{ V}$, master mode, $f_s = 48\text{ kHz}$, system clock = $512 f_s$, 24-bit data, unless otherwise noted.

DECIMATION FILTER FREQUENCY RESPONSE

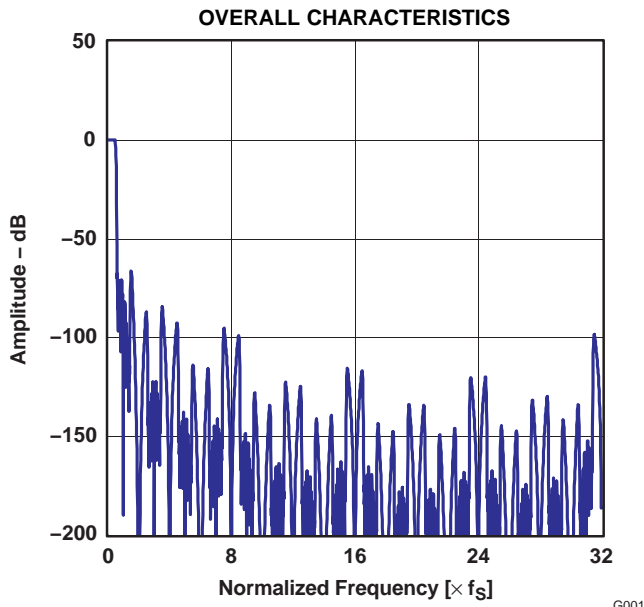

Figure 1.

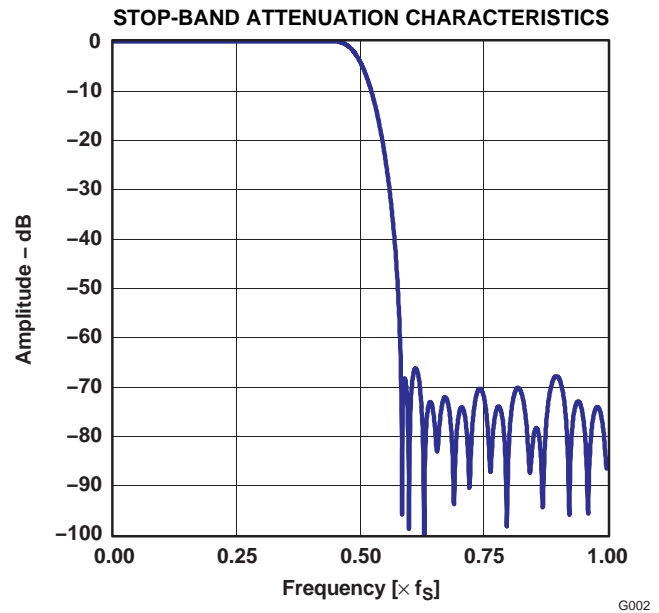

Figure 2.

TYPICAL PERFORMANCE CURVES OF INTERNAL FILTERS (Continued)

All specifications at $T_A = 25^\circ\text{C}$, $V_{CC} = 5\text{ V}$, $V_{DD} = 3.3\text{ V}$, master mode, $f_S = 48\text{ kHz}$, system clock = $512 f_S$, 24-bit data, unless otherwise noted.

DECIMATION FILTER FREQUENCY RESPONSE (Continued)

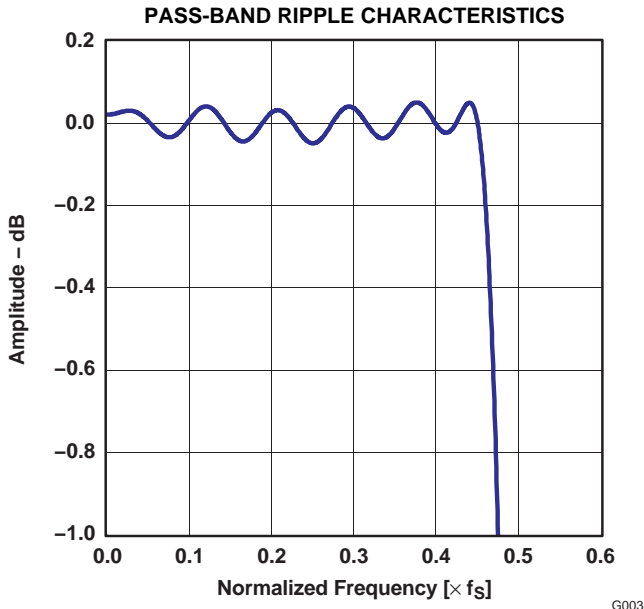

Figure 3.

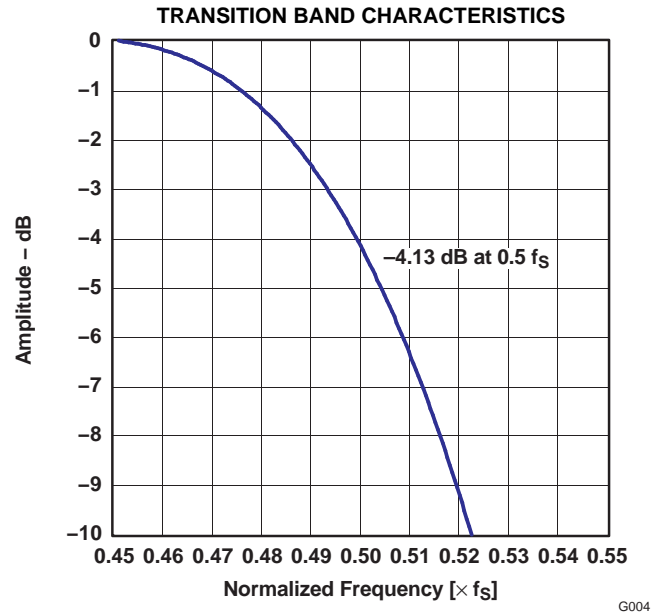

Figure 4.

HIGH-PASS FILTER FREQUENCY RESPONSE

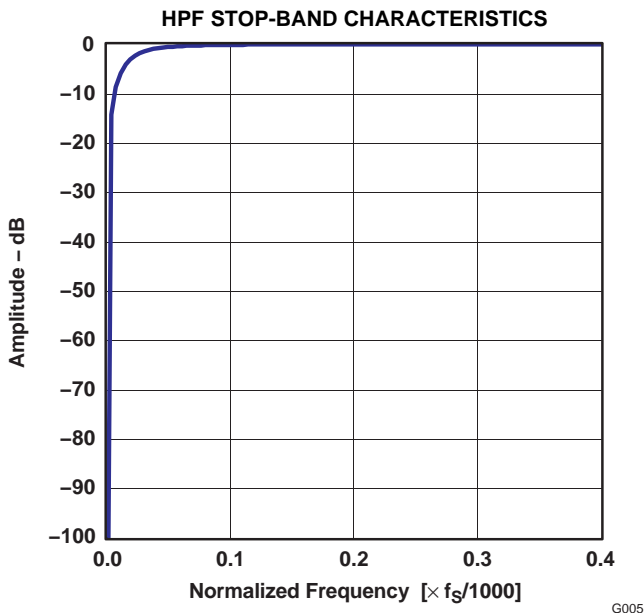

Figure 5.

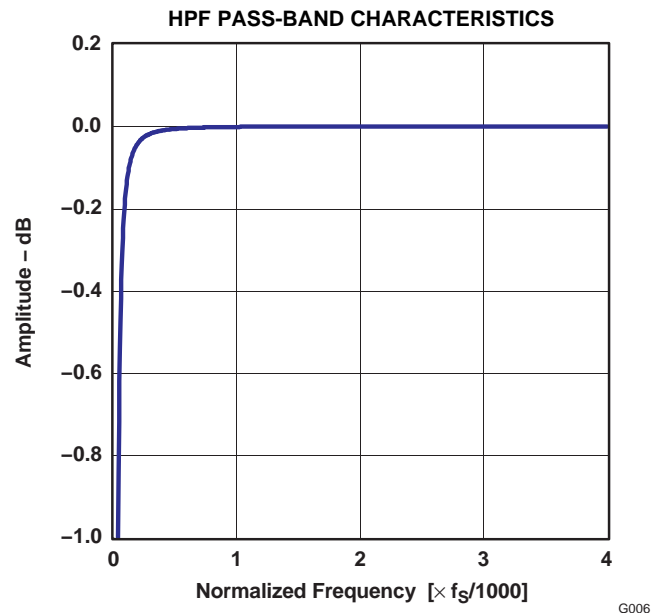

Figure 6.

TYPICAL PERFORMANCE CURVES

All specifications at $T_A = 25^\circ\text{C}$, $V_{CC} = 5\text{ V}$, $V_{DD} = 3.3\text{ V}$, master mode, $f_S = 48\text{ kHz}$, system clock = $512 f_S$, 24-bit data, unless otherwise noted.

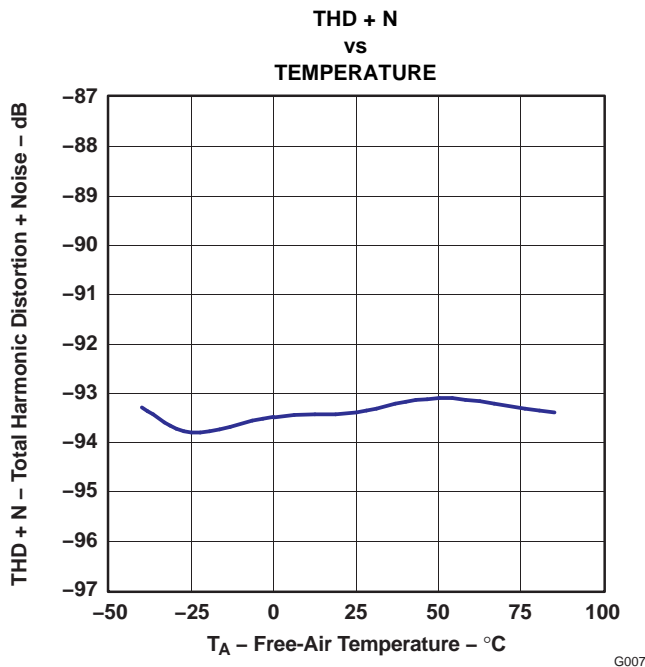

Figure 7.

G007

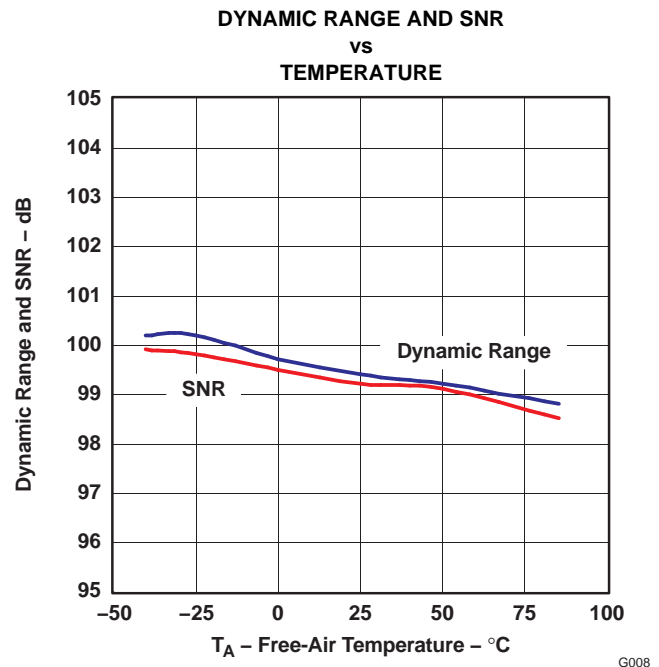

Figure 8.

G008

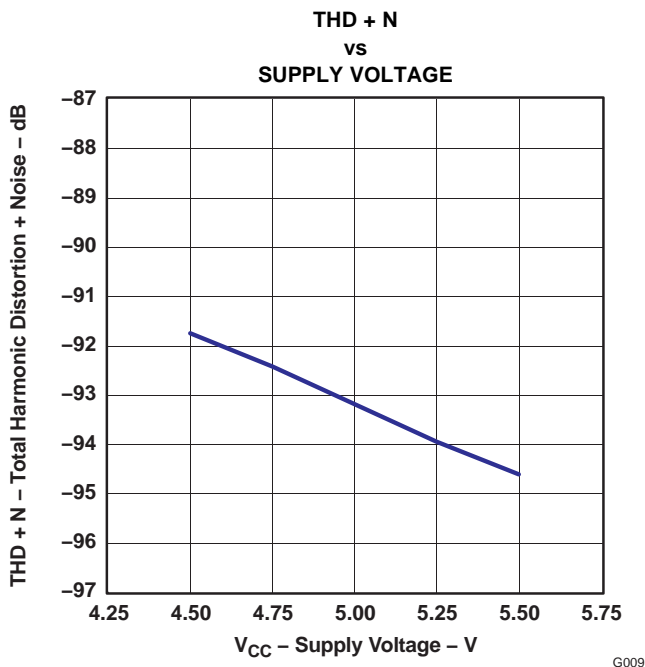

Figure 9.

G009

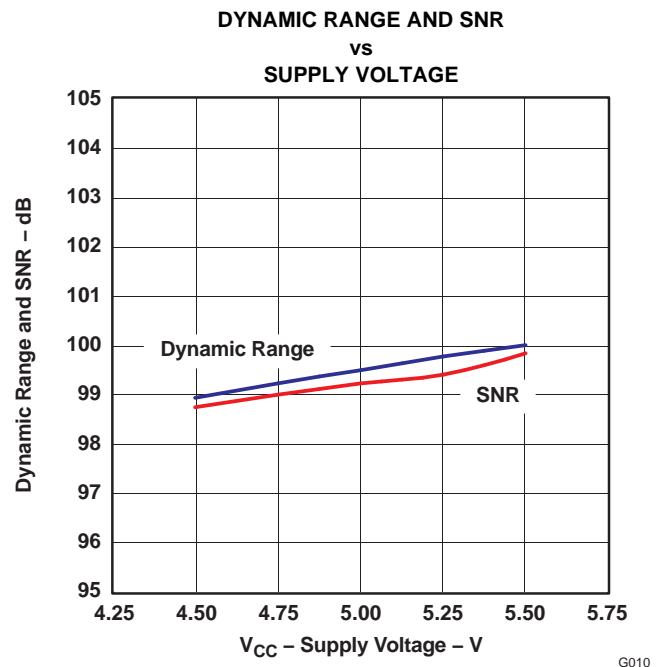

Figure 10.

G010

TYPICAL PERFORMANCE CURVES (Continued)

All specifications at $T_A = 25^\circ\text{C}$, $V_{CC} = 5\text{ V}$, $V_{DD} = 3.3\text{ V}$, master mode, $f_S = 48\text{ kHz}$, system clock = $512 f_S$, 24-bit data, unless otherwise noted.

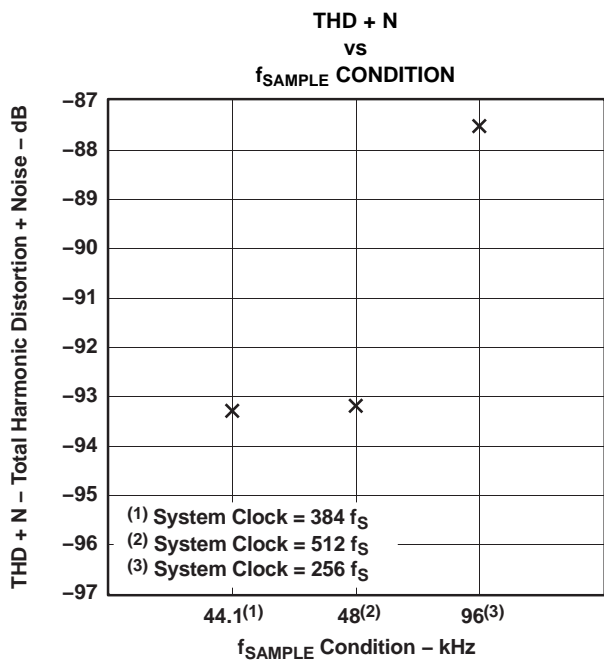

Figure 11.

G011

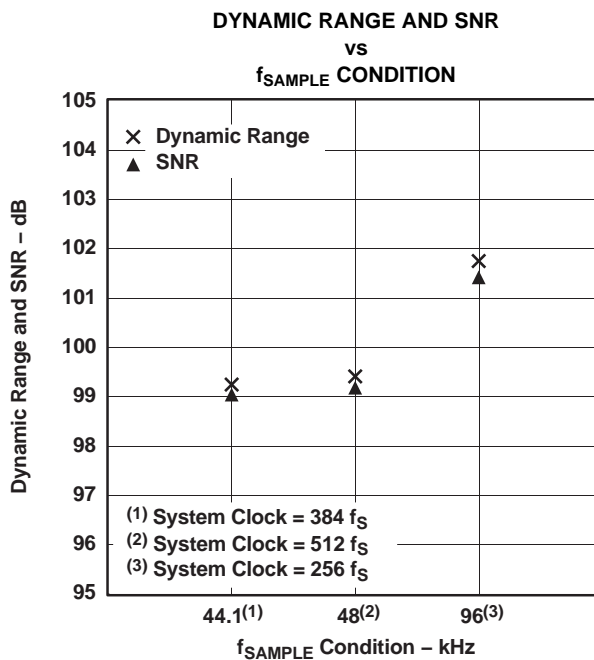

Figure 12.

G012

OUTPUT SPECTRUM

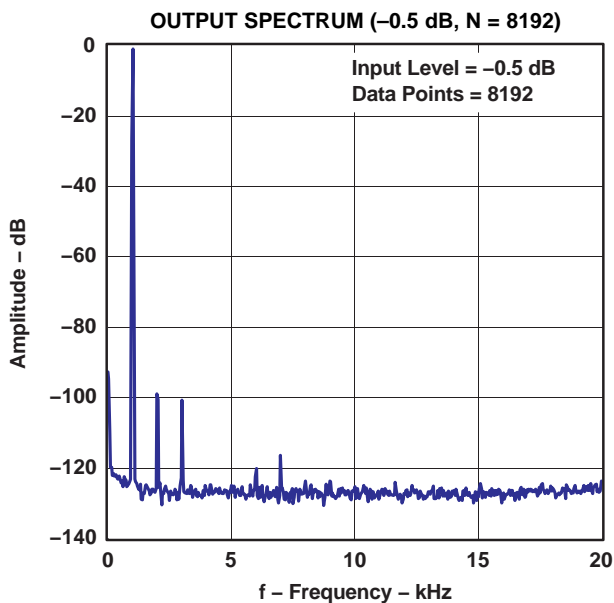

Figure 13.

G013

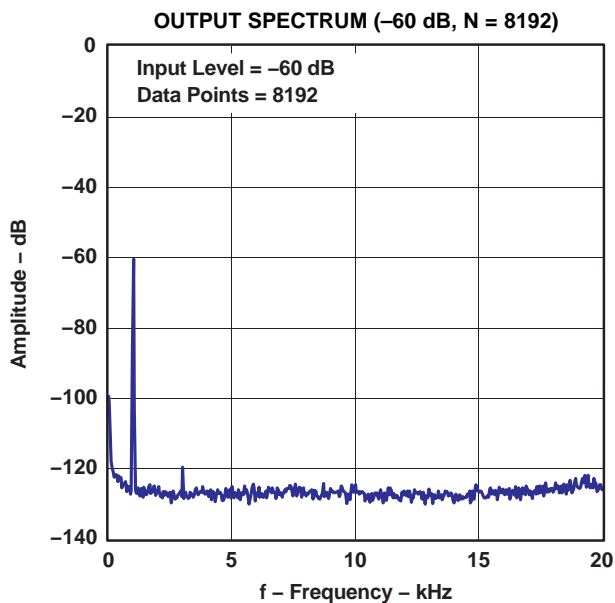

Figure 14.

G014

TYPICAL PERFORMANCE CURVES (Continued)

All specifications at $T_A = 25^\circ\text{C}$, $V_{CC} = 5\text{ V}$, $V_{DD} = 3.3\text{ V}$, master mode, $f_S = 48\text{ kHz}$, system clock = $512 f_S$, 24-bit data, unless otherwise noted.

OUTPUT SPECTRUM (Continued)

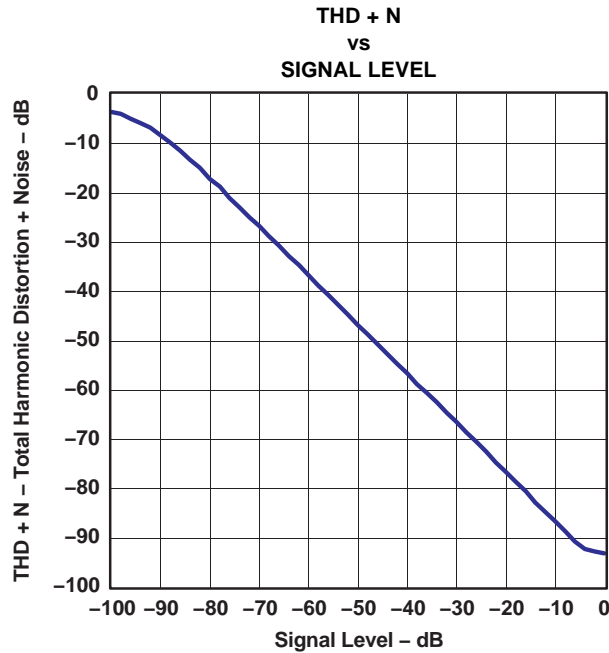

G015

Figure 15.

SUPPLY CURRENT

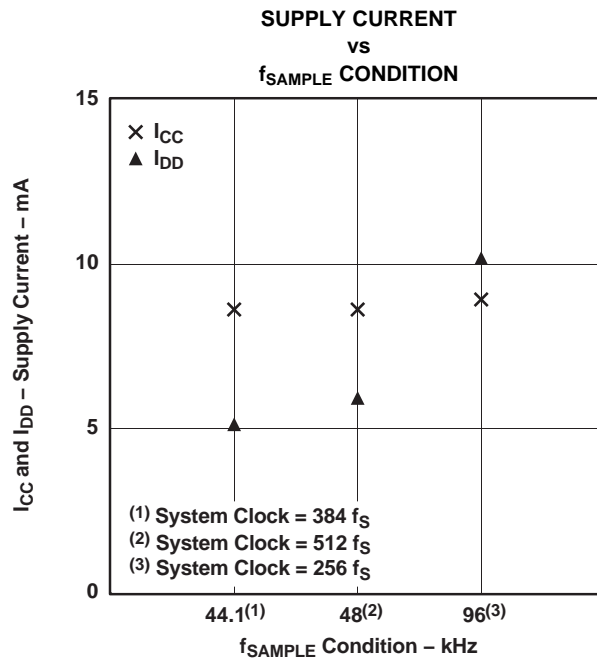

G016

Figure 16.

SYSTEM CLOCK

The PCM1808-Q1 supports $256 f_s$, $384 f_s$ and $512 f_s$ as system clock, where f_s is the audio sampling frequency. The system clock must be supplied on SCKI (pin 6).

The PCM1808-Q1 has a system clock detection circuit which automatically senses if the system clock is operating at $256 f_s$, $384 f_s$, or $512 f_s$ in slave mode. In master mode, the system clock frequency must be controlled through the serial control port, which uses MD1 (pin 111) and MD0 (pin 10). The system clock is divided down automatically to generate frequencies of $128 f_s$ and $64 f_s$, which are used to operate the digital filter and the delta-sigma modulator, respectively.

Table 1 shows some typical relationships between sampling frequency and system clock frequency, and Figure 17 shows system clock timing.

Table 1. Sampling Frequency and System Clock Frequency

SAMPLING FREQUENCY (kHz)	SYSTEM CLOCK FREQUENCY (f_{SCLK}) (MHz)		
	$256 f_s$	$384 f_s$	$512 f_s$
8	2.048	3.072	4.096
16	4.096	6.144	8.192
32	8.192	12.288	16.384
44.1	11.2896	16.9344	22.5792
48	12.288	18.432	24.576
64	16.384	24.576	32.768
88.2	22.5792	33.8688	45.1584
96	24.576	36.864	49.152

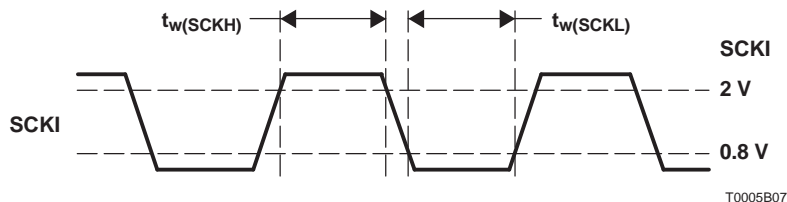

SYMBOL	PARAMETER	MIN	MAX	UNIT
$t_w(SCKH)$	System clock pulse duration, HIGH	8		ns
$t_w(SCKL)$	System clock pulse duration, LOW	8		ns
	System clock duty cycle	40%	60%	

Figure 17. System Clock Timing

FADE-IN AND FADE-OUT FUNCTIONS

The PCM1808-Q1 has fade-in and fade-out functions on DOUT (pin 9) to avoid pop noise, and the functions come into operation in some cases as described in several following sections. The level changes from 0 dB to mute or mute to 0 dB are performed using calculated pseudo S-shaped characteristics with zero-cross detection. Because of the zero-cross detection, the time needed for the fade in and fade out depends on the analog input frequency (f_{in}). It takes $48/f_{in}$ until processing is completed. If there is no zero cross during $8192/f_s$, DOUT is faded in or out by force during $48/f_s$ (TIME OUT). Figure 18 illustrates the fade-in and fade-out operation processing.

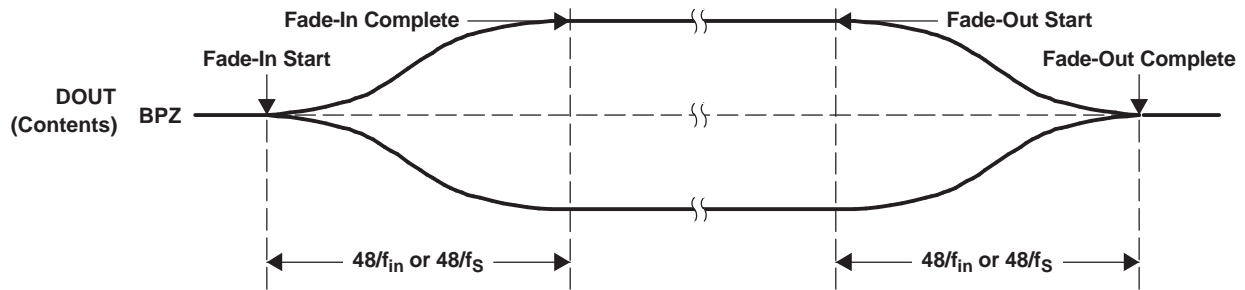

T0080-01

Figure 18. Fade-In and Fade-Out Operations

POWER ON

The PCM1808-Q1 has an internal power-on-reset circuit, and initialization (reset) is performed automatically when the power supply (V_{DD}) exceeds 2.2 V (typical). While $V_{DD} < 2.2$ V (typical), and for 1024 system-clock counts after $V_{DD} > 2.2$ V (typical), the PCM1808-Q1 stays in the reset state and the digital output is forced to zero. The digital output is valid after the reset state is released and the time of $8960/f_s$ has elapsed. Because the fade-in operation is performed, it takes additional time of $48/f_{in}$ or $48/f_s$ until the data corresponding to the analog input signal is obtained. Figure 19 illustrates the power-on timing and the digital output.

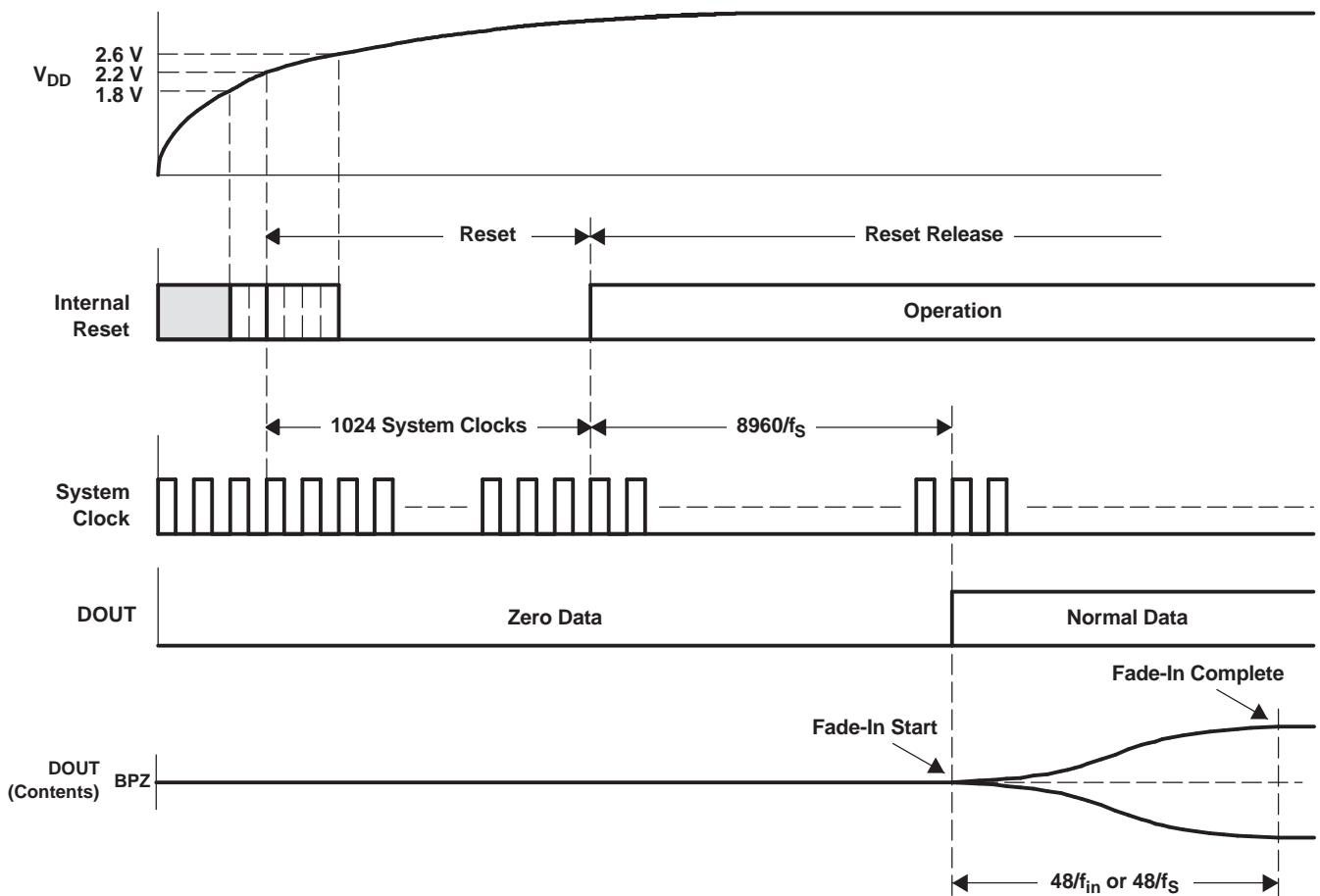

T0014-09

Figure 19. Power-On Timing

CLOCK-HALT POWER-DOWN AND RESET FUNCTION

The PCM1808-Q1 has a power-down and reset function, which is triggered by halting SCKI (pin 6) in both master and slave modes. The function is available anytime after power on. Reset and power down are performed automatically 4 μ s (minimum) after SCKI is halted. While the clock-halt reset is asserted, the PCM1808-Q1 stays in the reset and power-down mode, and DOUT (pin 9) is forced to zero. SCKI must be supplied to release the reset and power-down mode. The digital output is valid after the reset state is released and the time of 1024 SCKI + 8960/ f_s has elapsed. Because the fade-in operation is performed, it takes additional time of 48/ f_{in} or 48/ f_s until the level corresponding to the analog input signal is obtained. Figure 20 illustrates the clock-halt reset timing.

To avoid ADC performance degradation, BCK (pin 8) and LRCK (pin 7) are required to synchronize with SCKI within 4480/ f_s after SCKI is resumed. If it takes more than 4480/ f_s for BCK and LRCK to synchronize with SCKI, SCKI should be masked until the synchronization is achieved again, taking care of glitch and jitter. See the typical circuit connection diagram, Figure 26.

To avoid ADC performance degradation, the clock-halt reset also should be asserted when system clock SCKI or the audio interface clocks BCK and LRCK (sampling rate f_s) are changed on the fly.

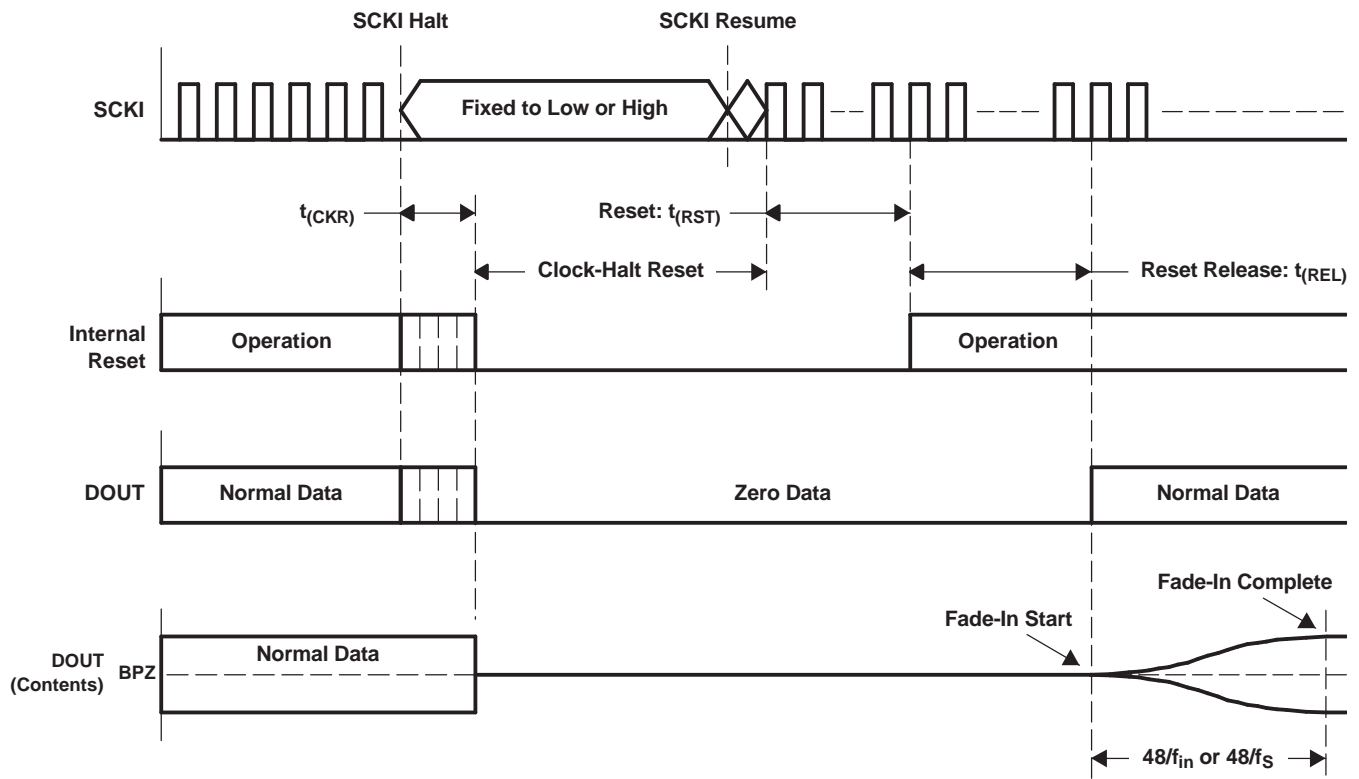

T0081-01

SYMBOL	PARAMETER	MIN	MAX	UNIT
$t_{(CKR)}$	Delay time from SCKI halt to internal reset	4		μ s
$t_{(RST)}$	Delay time from SCKI resume to reset release		1024 SCKI	μ s
$t_{(REL)}$	Delay time from reset release to DOUT output		8960/ f_s	μ s

Figure 20. Clock-Halt Power-Down and Reset Timing

SERIAL AUDIO DATA INTERFACE

The PCM1808-Q1 interfaces the audio system through LRCK (pin 7), BCK (pin 8), and DOUT (pin 9).

INTERFACE MODE

The PCM1808-Q1 supports master mode and slave mode as interface modes, which are selected by MD1 (pin 11) and MD0 (pin 10), as shown in [Table 2](#). MD1 and MD0 must be set prior to power on.

In master mode, the PCM1808-Q1 provides the timing of serial audio data communications between the PCM1808-Q1 and the digital audio processor or external circuit. While in slave mode, the PCM1808-Q1 receives the timing for data transfer from an external controller.

Table 2. Interface Modes

MD1 (Pin 11)	MD0 (Pin 10)	INTERFACE MODE
Low	Low	Slave mode (256 f _S , 384 f _S , 512 f _S autodetection)
Low	High	Master mode (512 f _S)
High	Low	Master mode (384 f _S)
High	High	Master mode (256 f _S)

Master mode

In master mode, BCK and LRCK work as output pins, and these pins are controlled by timing which is generated in the clock circuit of the PCM1808-Q1. The frequency of BCK is fixed at 64 BCK/frame.

Slave mode

In slave mode, BCK and LRCK work as input pins. The PCM1808-Q1 accepts 64-BCK/frame or 48-BCK/frame format (only for a 384-f_S system clock), not 32-BCK/frame format.

DATA FORMAT

The PCM1808-Q1 supports two audio data formats in both master and slave modes. The data formats are selected by FMT (pin 12), as shown in [Table 3](#). [Figure 21](#) illustrates the data formats in slave mode and master mode.

Table 3. Data Format

FORMAT NO.	FMT (Pin 12)	FORMAT
0	Low	I ² S, 24-bit
1	High	Left-justified, 24-bit

FORMAT 0: FMT = LOW

24-Bit, MSB-First, I²S

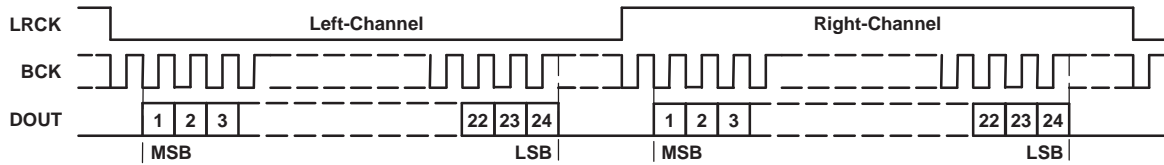

FORMAT 1: FMT = HIGH

24-Bit, MSB-First, Left-Justified

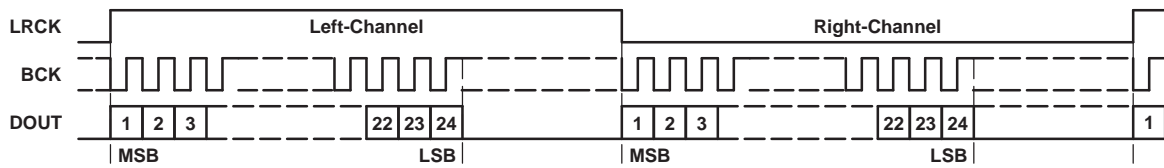

T0016-17

Figure 21. Audio Data Format (LRCK and BCK Work as Inputs in Slave Mode and as Outputs in Master Mode)

INTERFACE TIMING

Figure 22 and Figure 23 illustrate the interface timing in slave mode and master mode, respectively.

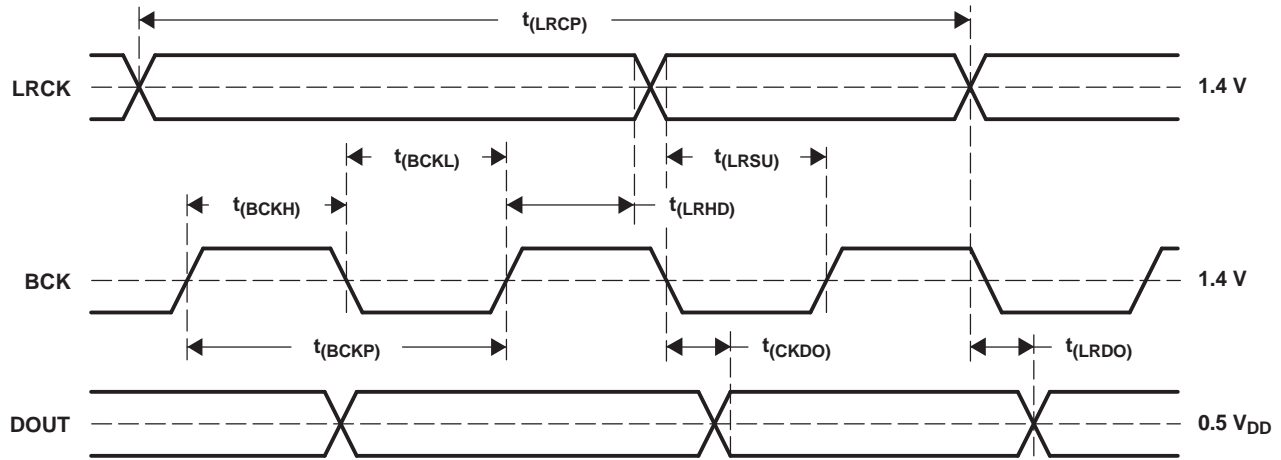

T0017-02

SYMBOL	PARAMETER	MIN	TYP	MAX	UNIT
t _(BCKP)	BCK period	1/(64 f _S)			ns
t _(BCKH)	BCK pulse duration, HIGH	1.5 × t _(SCKI)			ns
t _(BCKL)	BCK pulse duration, LOW	1.5 × t _(SCKI)			ns
t _(LRSU)	LRCK setup time to BCK rising edge	50			ns
t _(LRHD)	LRCK hold time to BCK rising edge	10			ns
t _(LRCP)	LRCK period	10			μs
t _(CKDO)	Delay time, BCK falling edge to DOUT valid	-10		40	ns
t _(LRDO)	Delay time, LRCK edge to DOUT valid	-10		40	ns
t _r	Rise time of all signals			20	ns
t _f	Fall time of all signals			20	ns

NOTE: Timing measurement reference level is 1.4 V for input and 0.5 V_{DD} for output. Rise and fall times are from 10% to 90% of the input/output signal swing. Load capacitance of DOUT is 20 pF. t_(SCKI) is the SCKI period.

Figure 22. Audio Data Interface Timing (Slave Mode: LRCK and BCK Work as Inputs)

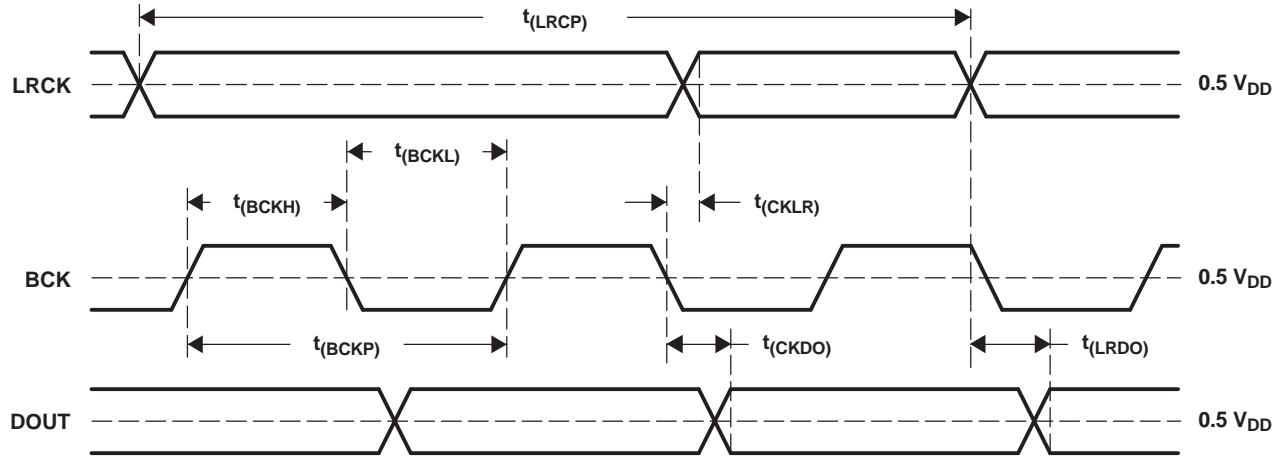

T0018-02

SYMBOL	PARAMETER	MIN	TYP	MAX	UNIT
$t_{(BCKP)}$	BCK period	150	$1/(64 f_s)$	2000	ns
$t_{(BCKH)}$	BCK pulse duration, HIGH	65		1200	ns
$t_{(BCKL)}$	BCK pulse duration, LOW	65		1200	ns
$t_{(CKLR)}$	Delay time, BCK falling edge to LRCK valid	-10		20	ns
$t_{(LRCP)}$	LRCK period	10	$1/f_s$	125	μs
$t_{(CKDO)}$	Delay time, BCK falling edge to DOUT valid	-10		20	ns
$t_{(LRDO)}$	Delay time, LRCK edge to DOUT valid	-10		20	ns
t_r	Rise time of all signals			20	ns
t_f	Fall time of all signals			20	ns

NOTE: Timing measurement reference level is $0.5 V_{DD}$. Rise and fall times are from 10% to 90% of the input/output signal swing. Load capacitance of all signals is 20 pF.

Figure 23. Audio Data Interface Timing (Master Mode: LRCK and BCK Work as Outputs)

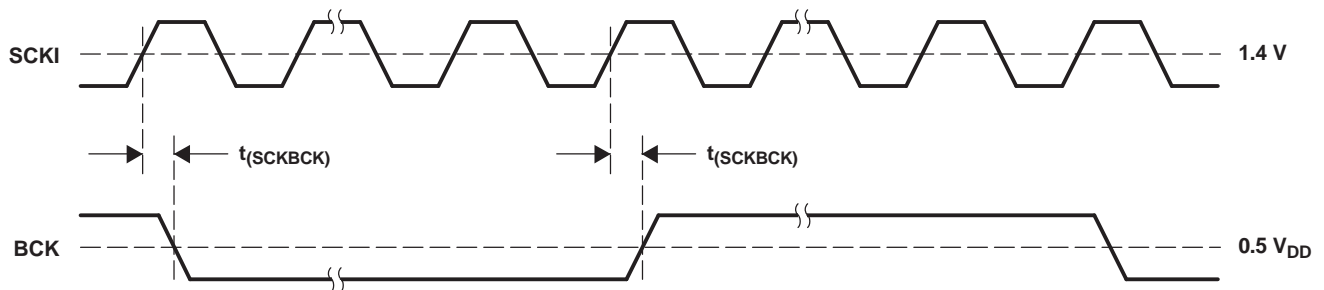

T0074-01

SYMBOL	PARAMETER	MIN	TYP	MAX	UNIT
$t_{(SCKBCK)}$	Delay time, SCKI rising edge to BCK edge	5		30	ns

NOTE: Timing measurement reference level is 1.4 V for input and $0.5 V_{DD}$ for output. Load capacitance of BCK is 20 pF. This timing is applied when SCKI frequency is less than 25 MHz.

Figure 24. Audio Clock Interface Timing (Master Mode: BCK Works as Output)

SYNCHRONIZATION WITH DIGITAL AUDIO SYSTEM

In slave mode, the PCM1808-Q1 operates under LRCK (pin 7), synchronized with system clock SCKI (pin 6). The PCM1808-Q1 does not require a specific phase relationship between LRCK and SCKI, but does require the synchronization of LRCK and SCKI.

If the relationship between LRCK and SCKI changes more than ± 6 BCKs for 64 BCK/frame (± 5 BCKs for 48 BCK/frame) during one sample period due to LRCK or SCKI jitter, internal operation of the ADC halts within $1/f_s$ and digital output is forced to zero data (BPZ code) until resynchronization between LRCK and SCKI is established.

In the case of changes less than ± 5 BCKs for 64 BCK/frame (± 4 BCKs for 48 BCK/frame), resynchronization does not occur and the previously described digital output control and discontinuity do not occur.

Figure 25 illustrates the digital output response for loss of synchronization and resynchronization. During undefined data, the PCM1808-Q1 can generate some noise in the audio signal. Also, the transition of normal data to undefined data creates a discontinuity in the digital output data, which can generate some noise in the audio signal. The digital output is valid after resynchronization completes and the time of $32/f_s$ has elapsed. Because the fade-in operation is performed, it takes additional time of $48/f_{in}$ or $48/f_s$ until the level corresponding to the analog input signal is obtained. If synchronization is lost during the fade-in or fade-out operation, the operation stops and DOUT (pin 9) is forced to zero data immediately. The fade-in operation resumes from mute after the time of $32/f_s$ following resynchronization.

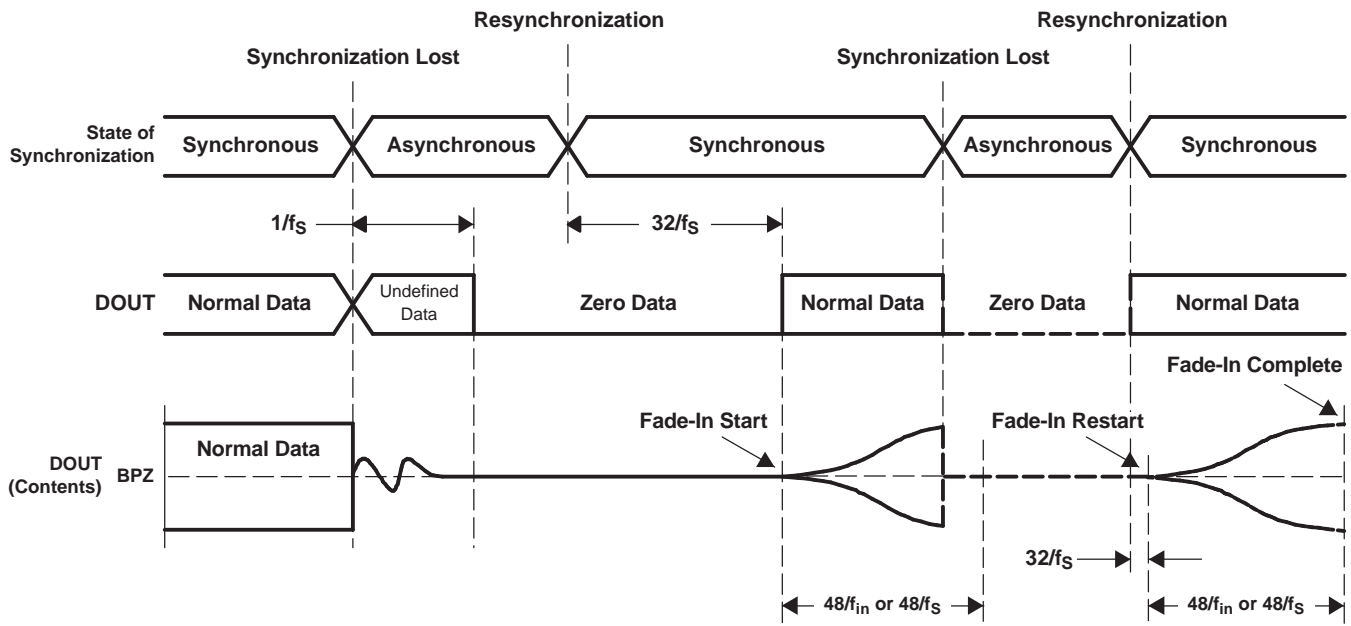

T0082-01

Figure 25. ADC Digital Output for Loss of Synchronization and Resynchronization

APPLICATION INFORMATION

TYPICAL CIRCUIT CONNECTION DIAGRAM

Figure 26 is a typical circuit connection diagram. The antialiasing low-pass filters are integrated on the analog inputs, V_{INL} and V_{INR} . If the performance of these filters is not adequate for an application, appropriate external antialiasing filters are needed. A passive RC filter (100 Ω and 0.01 μF to 1 k Ω and 1000 pF) generally is used.

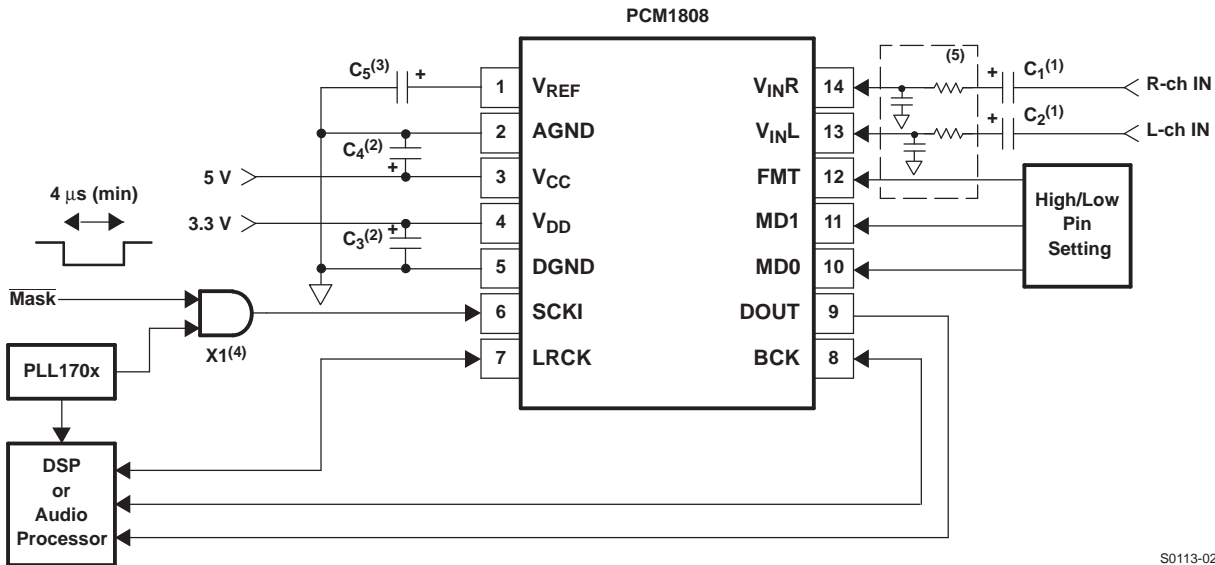

S0113-02

- (1) C1, C2: A 1- μF electrolytic capacitor gives 2.7 Hz ($\tau = 1 \mu\text{F} \times 60 \text{ k}\Omega$) cutoff frequency for the input HPF in normal operation and requires a power-on settling time with a 60-ms time constant in the power-on initialization period.
- (2) C3, C4: Bypass capacitors, 0.1- μF ceramic and 10- μF electrolytic, depending on layout and power supply
- (3) C5: 0.1- μF ceramic and 10- μF electrolytic capacitors are recommended.
- (4) X1: X1 masks the system clock input when using the clock-halt reset function with external control.
- (5) Optional external antialiasing filter could be required, depending on the application.

Figure 26. Typical Circuit Connection Diagram

BOARD DESIGN AND LAYOUT CONSIDERATIONS

V_{CC} , V_{DD} PINS

The digital and analog power supply lines to the PCM1808-Q1 should be bypassed to the corresponding ground pins with both 0.1- μF ceramic and 10- μF electrolytic capacitors as close to the pins as possible to maximize the dynamic performance of the ADC.

AGND, DGND PINS

To maximize the dynamic performance of the PCM1808-Q1, the analog and digital grounds are not internally connected. These grounds should have low impedance to avoid digital noise feedback into the analog ground. They should be connected directly to each other under the PCM1808-Q1 package to reduce potential noise problems.

V_{INL} , V_{INR} PINS

V_{INL} and V_{INR} are single-ended inputs. The antialias low-pass filters are integrated on these inputs to remove the high-frequency noise outside the audio band. If the performance of these filters is not adequate for an application, appropriate external antialiasing filters are required. A passive RC filter (100 Ω and 0.01 μF to 1 k Ω and 1000 pF) is generally used.

V_{REF} PIN

To ensure low source impedance of the ADC references, 0.1- μ F ceramic and 10- μ F electrolytic capacitors are recommended between V_{REF} and AGND. These capacitors should be located as close as possible to the V_{REF} pin to reduce dynamic errors on the ADC references.

DOUT PIN

The DOUT pin has a large load-drive capability, but if the DOUT line is long, locating a buffer near the PCM1808-Q1 and minimizing load capacitance is recommended to minimize the digital-analog crosstalk and maximize the dynamic performance of the ADC.

SYSTEM CLOCK

The quality of the system clock can influence dynamic performance, as the PCM1808-Q1 operates based on a system clock. Therefore, it may be necessary to consider the system clock duty, jitter, and the time difference between system clock transition and BCK or LRCK transition in slave mode.

REVISION HISTORY

Changes from Original (March, 2011) to Revision A	Page
• ROC CHANGES: Added 2.93 min and 3.23 max to analog input voltage row	2
• ELEC CHAR CHANGES: Added $-40^{\circ}\text{C} \leq T_A \leq 125^{\circ}\text{C}$ to the header for DC accuracy and the rows for system clock frequency, input logic level, and output logic level	3
• Added test condition row to $V_{IN} = V_{DD}$ (input logic current) at $-40^{\circ}\text{C} \leq T_A \leq 125^{\circ}\text{C}$ with typ value 65 and max value 150	3
• Added test condition row to $I_{OUT} = -4$ mA (output logic level) at $-40^{\circ}\text{C} \leq T_A \leq 125^{\circ}\text{C}$ with a min value of 2.7; added test condition of 25°C with min value of 2.8	3
• Added test condition of 25°C to $V_{IN} = -0.5$ dB, $f_S = 48$ kHz (THD + N) with max value of -87 , and added row with test condition of $-40^{\circ}\text{C} \leq T_A \leq 125^{\circ}\text{C}$ and max value -85	3
• Added test condition 25°C and min value of 95; added test condition row for $-40^{\circ}\text{C} \leq T_A \leq 125^{\circ}\text{C}$ with min value of 93 to $f_S = 48$ kHz, A-weighted row (dynamic range and signal-to-noise)	3
• Added test condition 25°C and min value of 93; added test condition row for $-40^{\circ}\text{C} \leq T_A \leq 125^{\circ}\text{C}$ with min value of 91 to $f_S = 48$ kHz (channel separation)	4
• Added min value $0.58 V_{CC}$ and max value $0.65 V_{CC}$ to input voltage; added $0.2 V_{CC}$ min and $0.8 V_{CC}$ max to center voltage; changed center voltage Vref to center voltage input range	4
• Added $-40^{\circ}\text{C} \leq T_A \leq 125^{\circ}\text{C}$ to input voltage, center voltage, digital filter performance header, supply current, and voltage range rows	4
• Added test condition row with $-40^{\circ}\text{C} \leq T_A \leq 125^{\circ}\text{C}$ to $f_S = 48$ kHz (supply current) with a typ value of 5.9 and a max value of 10	4

PACKAGING INFORMATION

Orderable Device	Status (1)	Package Type	Package Drawing	Pins	Package Qty	Eco Plan (2)	Lead/Ball Finish (6)	MSL Peak Temp (3)	Op Temp (°C)	Device Marking (4/5)	Samples
PCM1808QPWRQ1	ACTIVE	TSSOP	PW	14	2000	Green (RoHS & no Sb/Br)	NIPDAU	Level-3-260C-168 HR	-40 to 125	P1808Q	Samples

(1) The marketing status values are defined as follows:

ACTIVE: Product device recommended for new designs.

LIFEBUY: TI has announced that the device will be discontinued, and a lifetime-buy period is in effect.

NRND: Not recommended for new designs. Device is in production to support existing customers, but TI does not recommend using this part in a new design.

PREVIEW: Device has been announced but is not in production. Samples may or may not be available.

OBSOLETE: TI has discontinued the production of the device.

(2) **RoHS:** TI defines "RoHS" to mean semiconductor products that are compliant with the current EU RoHS requirements for all 10 RoHS substances, including the requirement that RoHS substance do not exceed 0.1% by weight in homogeneous materials. Where designed to be soldered at high temperatures, "RoHS" products are suitable for use in specified lead-free processes. TI may reference these types of products as "Pb-Free".

RoHS Exempt: TI defines "RoHS Exempt" to mean products that contain lead but are compliant with EU RoHS pursuant to a specific EU RoHS exemption.

Green: TI defines "Green" to mean the content of Chlorine (Cl) and Bromine (Br) based flame retardants meet JS709B low halogen requirements of <=1000ppm threshold. Antimony trioxide based flame retardants must also meet the <=1000ppm threshold requirement.

(3) MSL, Peak Temp. - The Moisture Sensitivity Level rating according to the JEDEC industry standard classifications, and peak solder temperature.

(4) There may be additional marking, which relates to the logo, the lot trace code information, or the environmental category on the device.

(5) Multiple Device Markings will be inside parentheses. Only one Device Marking contained in parentheses and separated by a "~" will appear on a device. If a line is indented then it is a continuation of the previous line and the two combined represent the entire Device Marking for that device.

(6) Lead/Ball Finish - Orderable Devices may have multiple material finish options. Finish options are separated by a vertical ruled line. Lead/Ball Finish values may wrap to two lines if the finish value exceeds the maximum column width.

Important Information and Disclaimer:The information provided on this page represents TI's knowledge and belief as of the date that it is provided. TI bases its knowledge and belief on information provided by third parties, and makes no representation or warranty as to the accuracy of such information. Efforts are underway to better integrate information from third parties. TI has taken and continues to take reasonable steps to provide representative and accurate information but may not have conducted destructive testing or chemical analysis on incoming materials and chemicals. TI and TI suppliers consider certain information to be proprietary, and thus CAS numbers and other limited information may not be available for release.

In no event shall TI's liability arising out of such information exceed the total purchase price of the TI part(s) at issue in this document sold by TI to Customer on an annual basis.

OTHER QUALIFIED VERSIONS OF PCM1808-Q1 :

- Catalog: [PCM1808](#)

NOTE: Qualified Version Definitions:

- Catalog - TI's standard catalog product

TAPE AND REEL INFORMATION
REEL DIMENSIONS

TAPE DIMENSIONS

A0	Dimension designed to accommodate the component width
B0	Dimension designed to accommodate the component length
K0	Dimension designed to accommodate the component thickness
W	Overall width of the carrier tape
P1	Pitch between successive cavity centers

TAPE AND REEL INFORMATION

*All dimensions are nominal

Device	Package Type	Package Drawing	Pins	SPQ	Reel Diameter (mm)	Reel Width W1 (mm)	A0 (mm)	B0 (mm)	K0 (mm)	P1 (mm)	W (mm)	Pin1 Quadrant
PCM1808QPWRQ1	TSSOP	PW	14	2000	330.0	12.4	6.9	5.6	1.6	8.0	12.0	Q1

TAPE AND REEL BOX DIMENSIONS



*All dimensions are nominal

Device	Package Type	Package Drawing	Pins	SPQ	Length (mm)	Width (mm)	Height (mm)
PCM1808QPWRQ1	TSSOP	PW	14	2000	367.0	367.0	35.0

PW (R-PDSO-G14)

PLASTIC SMALL OUTLINE

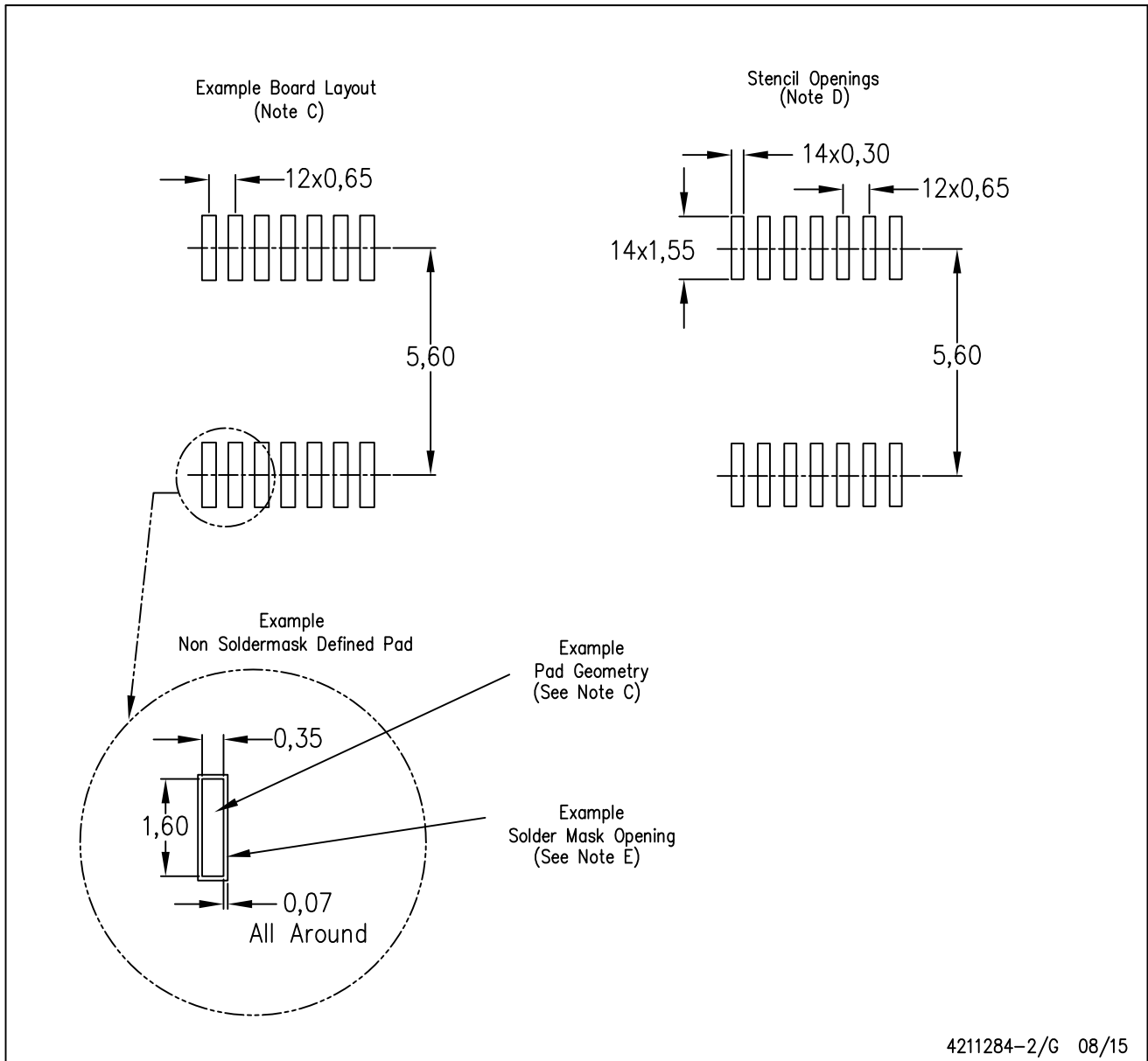

4211284-2/G 08/15

- NOTES:
- All linear dimensions are in millimeters.
 - This drawing is subject to change without notice.
 - Publication IPC-7351 is recommended for alternate designs.
 - Laser cutting apertures with trapezoidal walls and also rounding corners will offer better paste release. Customers should contact their board assembly site for stencil design recommendations. Refer to IPC-7525 for other stencil recommendations.
 - Customers should contact their board fabrication site for solder mask tolerances between and around signal pads.

IMPORTANT NOTICE AND DISCLAIMER

TI PROVIDES TECHNICAL AND RELIABILITY DATA (INCLUDING DATASHEETS), DESIGN RESOURCES (INCLUDING REFERENCE DESIGNS), APPLICATION OR OTHER DESIGN ADVICE, WEB TOOLS, SAFETY INFORMATION, AND OTHER RESOURCES "AS IS" AND WITH ALL FAULTS, AND DISCLAIMS ALL WARRANTIES, EXPRESS AND IMPLIED, INCLUDING WITHOUT LIMITATION ANY IMPLIED WARRANTIES OF MERCHANTABILITY, FITNESS FOR A PARTICULAR PURPOSE OR NON-INFRINGEMENT OF THIRD PARTY INTELLECTUAL PROPERTY RIGHTS.

These resources are intended for skilled developers designing with TI products. You are solely responsible for (1) selecting the appropriate TI products for your application, (2) designing, validating and testing your application, and (3) ensuring your application meets applicable standards, and any other safety, security, or other requirements. These resources are subject to change without notice. TI grants you permission to use these resources only for development of an application that uses the TI products described in the resource. Other reproduction and display of these resources is prohibited. No license is granted to any other TI intellectual property right or to any third party intellectual property right. TI disclaims responsibility for, and you will fully indemnify TI and its representatives against, any claims, damages, costs, losses, and liabilities arising out of your use of these resources.

TI's products are provided subject to TI's Terms of Sale (www.ti.com/legal/termsofsale.html) or other applicable terms available either on ti.com or provided in conjunction with such TI products. TI's provision of these resources does not expand or otherwise alter TI's applicable warranties or warranty disclaimers for TI products.

Mailing Address: Texas Instruments, Post Office Box 655303, Dallas, Texas 75265
Copyright © 2020, Texas Instruments Incorporated