

USB 2.0 High-Speed (480 Mbps) Signal Switch with Vbus Short Protection

Features

- USB 2.0 compliant (high speed and full speed)
- R_{ON} is 3.0Ω typical @ $V_{DD} = 3.0V$
- Low bit-to-bit skew
- Low Crosstalk: $-33dB$ @ 480 Mbps
- Off Isolation: $-30dB$ @ 480 Mbps
- Near-Zero propagation delay: 250ps
- Channel On Capacitance: 6.0pF (typ)
- V_{DD} Operating Range: 3.0V to 3.6V
- Data pin I/O ESD (pins 1, 2, 4, 5, 6, and 7): $\pm 4kV$ contact per IEC61000-4-2 spec
- $-3dB$ BW of 1400MHz
- I/O pins have over-voltage protection and can tolerate a short to Vbus
- Packaging (Pb-free & Green):
 - 10-contact TQFN, 1.3mm x 1.6mm x 0.75mm (ZL10)

Description

The PI3USB103 is a single differential channel 2:1 multiplexer/demultiplexer USB 2.0 Switch. Industry leading advantages include a propagation delay of less than 250ps, resulting from its low channel resistance and I/O capacitance. The device multiplexes differential outputs from a USB Host device to one of two corresponding outputs. The switch is bidirectional and offers little or no attenuation of the high-speed signals at the outputs. It is designed for low bit-to-bit skew, high channel-to-channel noise isolation and is compatible with various standards, such as High Speed USB 2.0 (480 Mb/s).

The PI3USB103 offers over voltage protection per the USB 2.0 specification. With the chip powered on or off, all I/O pins can withstand a short to Vbus. If $V_{DD} = 0V$, the I/Os can still have signals present, and the signal will NOT leak through to V_{DD} .

Application

- Routes signals for USB 2.0
- Hand-held devices

Block Diagram

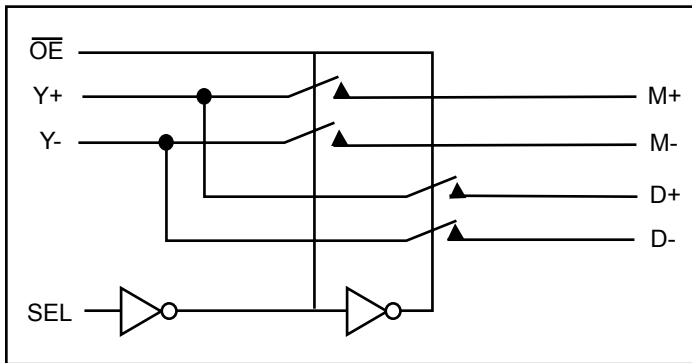

Truth Table

SEL	\overline{OE}	Y+	Y-
X	H	Hi-Z	Hi-Z
L	L	M+	M-
H	L	D+	D-

Pin Description

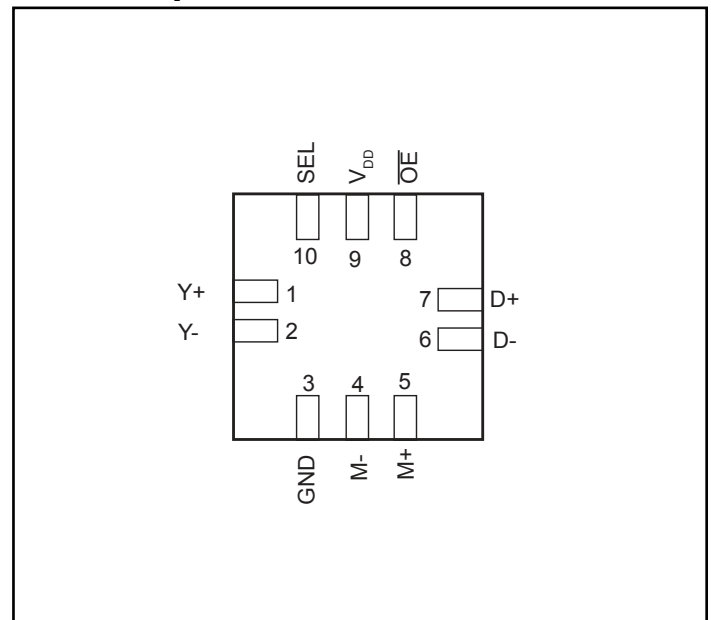

Maximum Ratings

(Above which useful life may be impaired. For user guidelines, not tested.)

Storage Temperature	-65°C to +150°C
Supply Voltage to Ground Potential	-0.5V to +4.0V
DC Input Voltage	-0.5V to +7V
DC Output Current	120mA
Power Dissipation	0.5W

Note: Stresses greater than those listed under MAXIMUM RATINGS may cause permanent damage to the device. This is a stress rating only and functional operation of the device at these or any other conditions above those indicated in the operational sections of this specification is not implied. Exposure to absolute maximum rating conditions for extended periods may affect reliability.

DC Electrical Characteristics for USB 2.0 Switching over Operating Range

($T_A = -40^\circ\text{C}$ to $+85^\circ\text{C}$, $V_{DD} = 3.0 - 3.6\text{V}$)

Parameter	Description	Test Conditions ⁽¹⁾		Min.	Typ. ⁽²⁾	Max.	Units
V_{IH}	Input HIGH Voltage	Guaranteed HIGH level	$V_{DD} = 3.3\text{V}$	1.3		V_{DD}	V
V_{IL}	Input LOW Voltage	Guaranteed HIGH level		GND		0.6	
V_{IK}	Clamp Diode Voltage	$V_{DD} = \text{Max.}, I_{IK} = -18\text{mA}$				-1.2	
I_{IH}	Input HIGH Current	$V_{DD} = \text{Max.}, V_{IH} = V_{DD}$				± 5	μA
I_{IL}	Input LOW Current	$V_{DD} = \text{Max.}, V_{IL} = \text{GND}$				± 5	
R_{ON}	Switch On-Resistance for USB 2.0 HS signal ⁽³⁾	$V_{DD} = \text{Min.}, -0.4\text{V} \leq V_{\text{input}} \leq 1.0\text{V}, I_{ON} = -40\text{mA}$			3.0	5.0	Ω
R_{ON}	Switch On-Resistance for USB FS signal	$V_{DD} = \text{min.}, 0\text{V} \leq V_{\text{input}} \leq 3.3\text{V}$				9	
R_{ON}	Switch On-Resistance for MHL signal	$V_{DD} = \text{min.}, 2\text{V} \leq V_{\text{input}} \leq 3.3\text{V}$				9	
$R_{ON(\text{flat})}$	On-resistance flatness	$V_{DD} = \text{min.}, -0.4\text{V} \leq V_{\text{input}} \leq 1.0\text{V}$			0.15	0.5	
ΔR_{ON}	On-Resistance match from center ports to any other port ⁽³⁾	$V_{DD} = \text{Min.}, -0.4\text{V} \leq V_{\text{input}} \leq 0.4\text{V}, I_{ON} = -40\text{mA}$			0.9	2.0	
I_{OZ}	I/O leakage current when port is off	$V_{DD} = 3.6\text{V}, V_{\text{input}} = 0 \text{ to } 3.6\text{V}, \text{switch} = \text{off}, \text{OE} = \text{HIGH}$				± 2	μA
I_{OFF}	Signal leakage when chip is off	$V_{DD} = 0\text{V}, V_{\text{input}} = 0 \text{ to } 7\text{V}$				± 10	μA

Notes:

- For max. or min. conditions, use appropriate value specified under Electrical Characteristics for the applicable device type.
- $V_{DD} = 3.0 - 3.6\text{V}$, $T_A = 25^\circ\text{C}$ ambient and maximum loading.
- Measured by the voltage drop between D and D_n pin at indicated current through the Switch On-Resistance is determined by the lower of the voltages on the two (D, D_n) pins.

Power Supply Characteristics ($V_{DD} = 3.0 - 3.6\text{V}$)

Parameters	Description	Test Conditions ⁽¹⁾	Min.	Typ.	Max.	Units
I_{CC}	Power Supply Current	$V_{DD} = \text{Max.}, V_{\text{SEL}} = \text{GND or } V_{DD}, \overline{\text{OE}} = \text{LOW}$			75	μA
		$V_{DD} = \text{Max.}, V_{\text{SEL}} = 1.5\text{V} - 2.1\text{V}$,			100	μA
I_{CCq}	Quiescent Power Supply Current	$V_{DD} = 3.3\text{V}, V_{\text{SEL}} = \text{GND or } V_{DD}$,			6	μA
		$V_{DD} = 3.3\text{V}, V_{\text{SEL}} = 1.5\text{V} - 2.1\text{V}$,			8	μA

Notes:

- For max. or min. conditions, use appropriate value specified under Electrical Characteristics for the applicable device type.

Capacitance ($T_A = 25^\circ\text{C}$, $f = 1\text{MHz}$)

Parameters ⁽³⁾	Description	Test Conditions ⁽¹⁾	Typ. ⁽²⁾	Max.	Units
C_{IN}	Input Capacitance	$V_{SEL} = 0\text{V}$	2.7	3.0	pF
C_{OFF}	Switch Capacitance, Switch OFF		2.8	3.0	
C_{ON}	Switch Capacitance, Switch ON		6.0	6.5	

Dynamic Electrical Characteristics Over the Operating Range

Parameters	Description	Test Conditions	Min.	Typ. ⁽²⁾	Max.	Units
X_{TALK}	Crosstalk	$R_L = 50\Omega$	$f = 240\text{ MHz}$ -35	-39		dB
O_{IRR}	OFF Isolation		$f = 825\text{ MHz}$ -25	-28		
			$f = 240\text{ MHz}$ -29	-32		
			$f = 825\text{ MHz}$ -20	-23		
BW	-3dB Bandwidth	$R_L = 50\Omega$	1100	1400		MHz
BW	-0.5dB Bandwidth	$R_L = 50\Omega$	150	400		MHz
IN	Insertion Loss	$f = 240\text{ MHz}$ $f = 825\text{ MHz}$ $f = 1.0\text{ GHz}$ $f = 1.125\text{ GHz}$		0.47 1.8 2.2 2.4	0.67 2.4 2.6 3.0	dB

Notes:

- For max. or min. conditions, use appropriate value specified under Electrical Characteristics for the applicable device type.
- Typical values are at $V_{DD} = 3.3\text{V}$, $T_A = 25^\circ\text{C}$ ambient and maximum loading.
- This parameter is determined by device characterization but is not production tested.

Switching Characteristics

Parameters	Description	Test Conditions ⁽¹⁾	Min.	Typ.	Max.	Units
t_{PD}	Propagation Delay ^(2,3)	See Test Circuit for Electrical Charac- teristics		0.25	0.35	ns
t_{PZH} , t_{PZL}	Line Enable Time - SEL, \overline{OE} to D(+/-), M(+/-)		0.5		60	
t_{PHZ} , t_{PLZ}	Line Disable Time - SEL, \overline{OE} to D(+/-), M(+/-)		0.5		60	
t_{SKC-C}	Output skew, channel-to-channel ⁽²⁾			3.5	14	ps

Notes:

- For max. or min. conditions, use appropriate value specified under Electrical Characteristics for the applicable device type.
- Guaranteed by design.
- The switch contributes no propagational delay other than the RC delay of the On-Resistance of the switch and the load capacitance. The time constant for the switch alone is of the order of 0.25ns for 10pF load. Since this time constant is much smaller than the rise/fall times of typical driving signals, it adds very little propagational delay to the system. Propagational delay of the switch when used in a system is determined by the driving circuit on the driving side of the switch and its interactions with the load on the driven side.

Test Circuit for Dynamic Electrical Characteristics

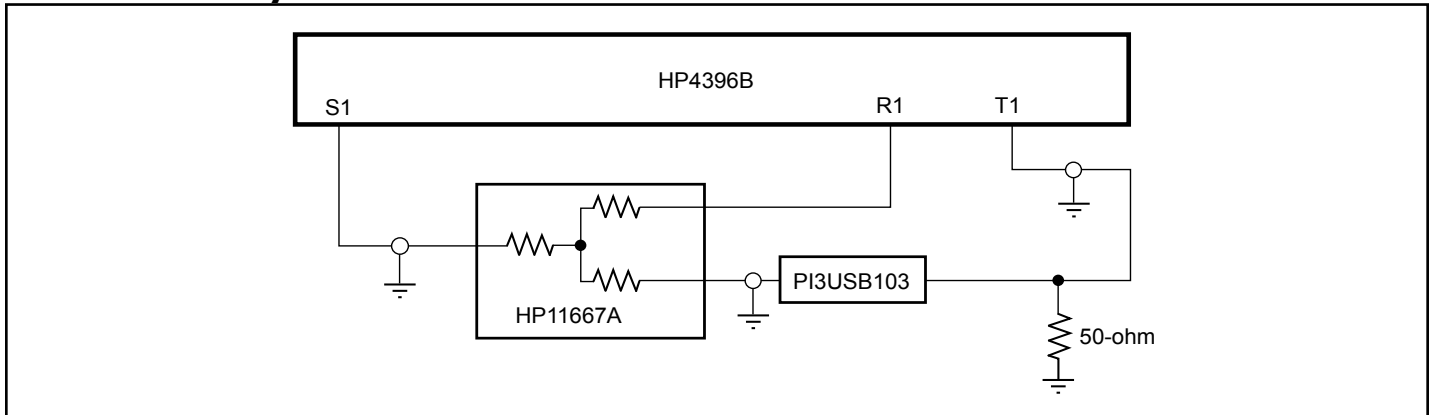

Test Circuit for Electrical Characteristics

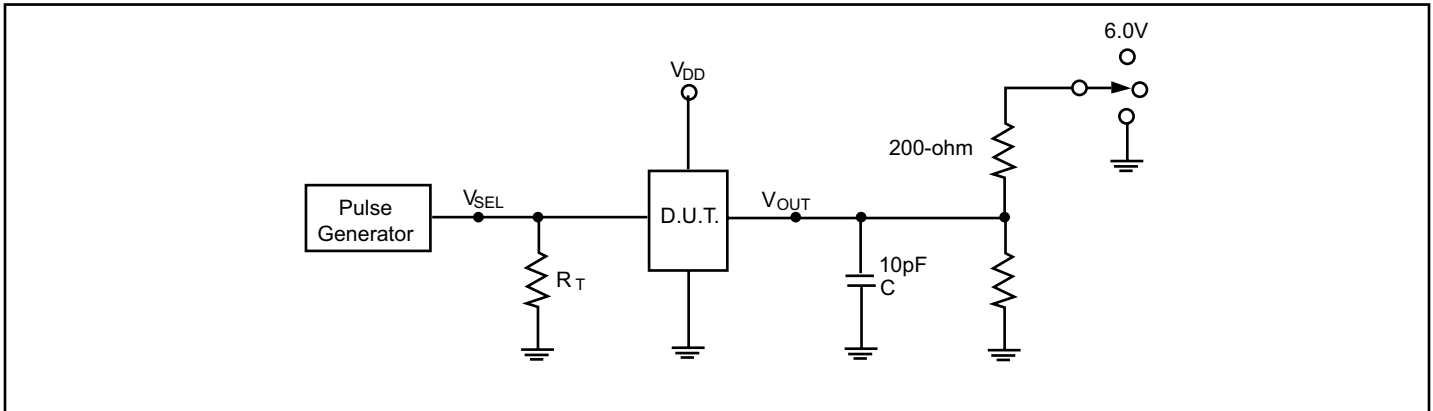

Notes:

C_L = Load capacitance: includes jig and probe capacitance.

R_T = Termination resistance: should be equal to Z_{OUT} of the Pulse Generator

All input impulses are supplied by generators having the following characteristics: $PRR \leq \text{MHz}$, $Z_O = 50\Omega$, $t_r \leq 2.5\text{ns}$, $t_f \leq 2.5\text{ns}$.

The outputs are measured one at a time with on transition per measurement.

Switch Positions

Test	Switch
t_{PLZ} , t_{PZL}	6.0V
t_{PHZ} , t_{PZH}	GND
Prop Delay	Open

Switching Waveforms

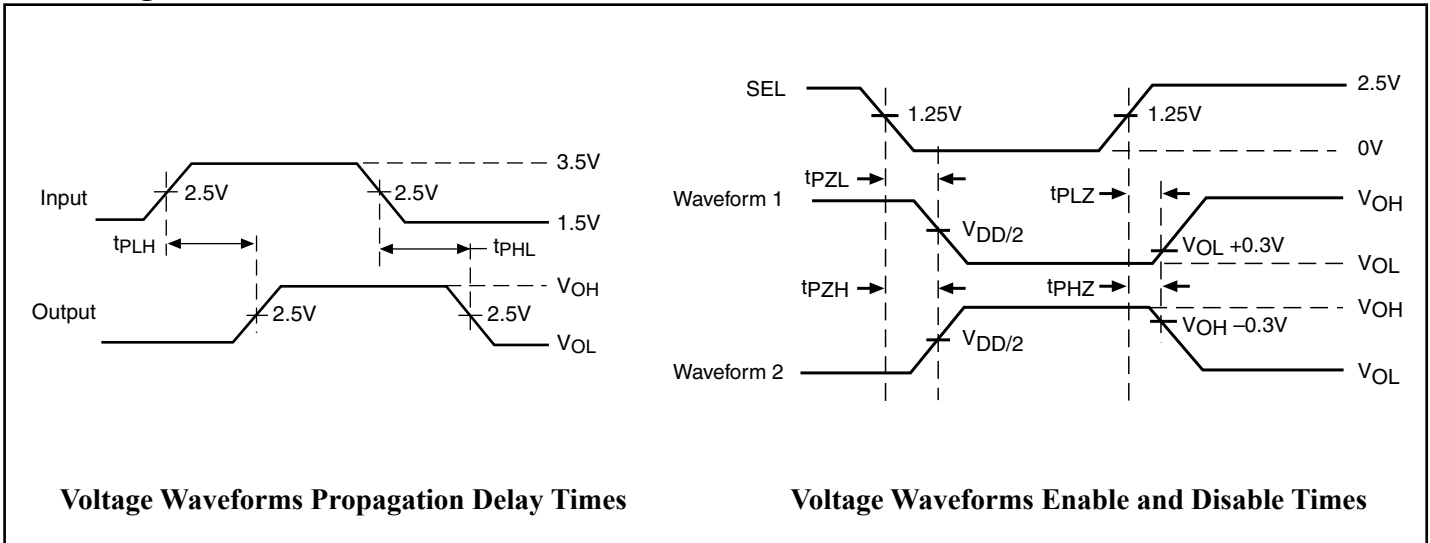

Applications Information

Logic Inputs

The logic control inputs can be driven up to +3.6V regardless of the supply voltage. For example, given a +3.3V supply, the output enables or select pins may be driven low to 0V and high to 3.6V. Driving IN Rail-to-Rail[®] minimizes power consumption.

Power Supply Sequencing

Since this product does not contain any PMOS parasitic at the I/O pins, proper supply sequencing is not required.

Rail-to-Rail is a registered trademark of Nippon Motorola, Ltd.

PI3USB103

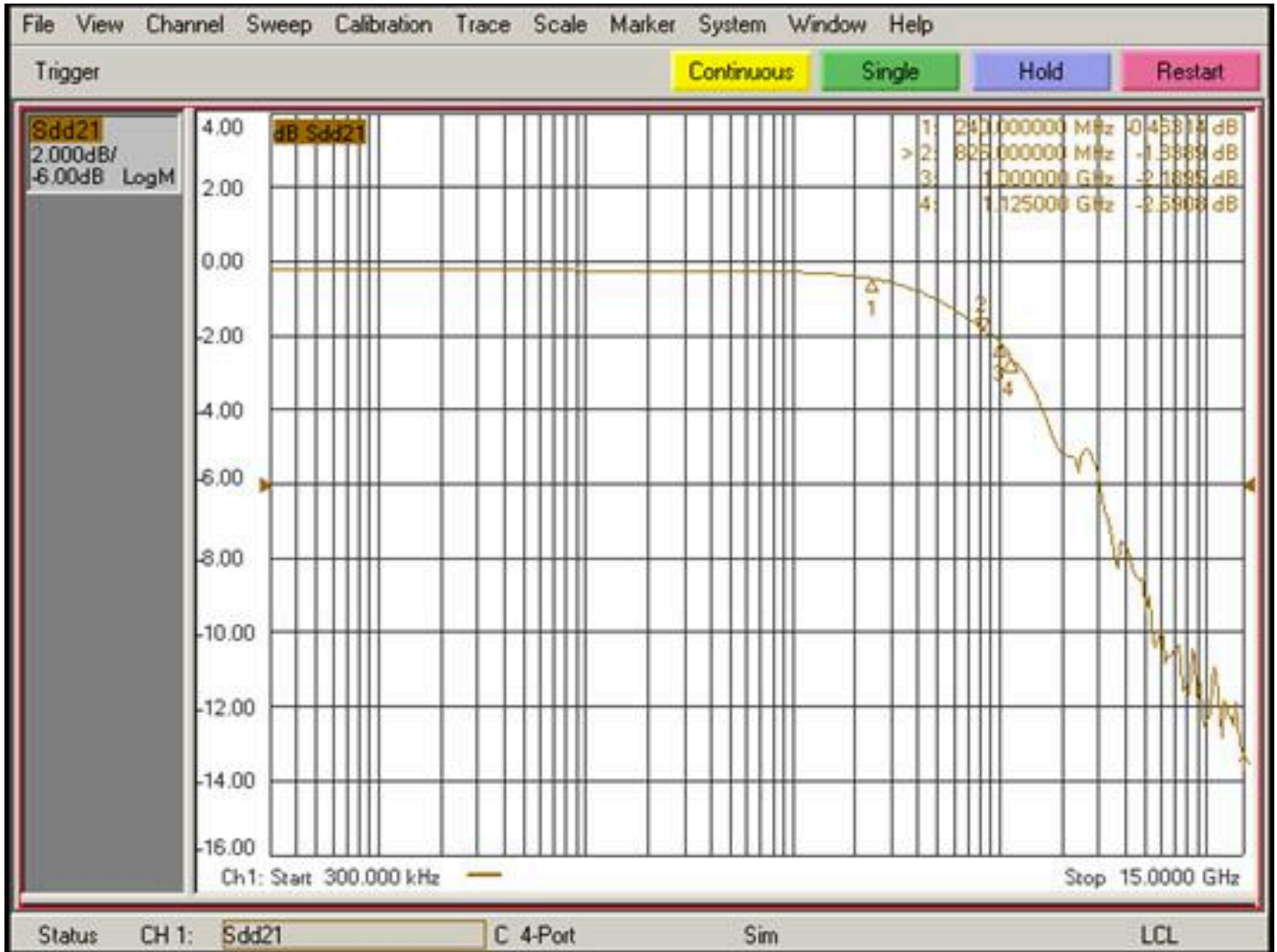

Differential Insertion loss, $V_{DD} = 3.3V$

Packaging Mechanicals: 10-Contact TQFN (ZL10)

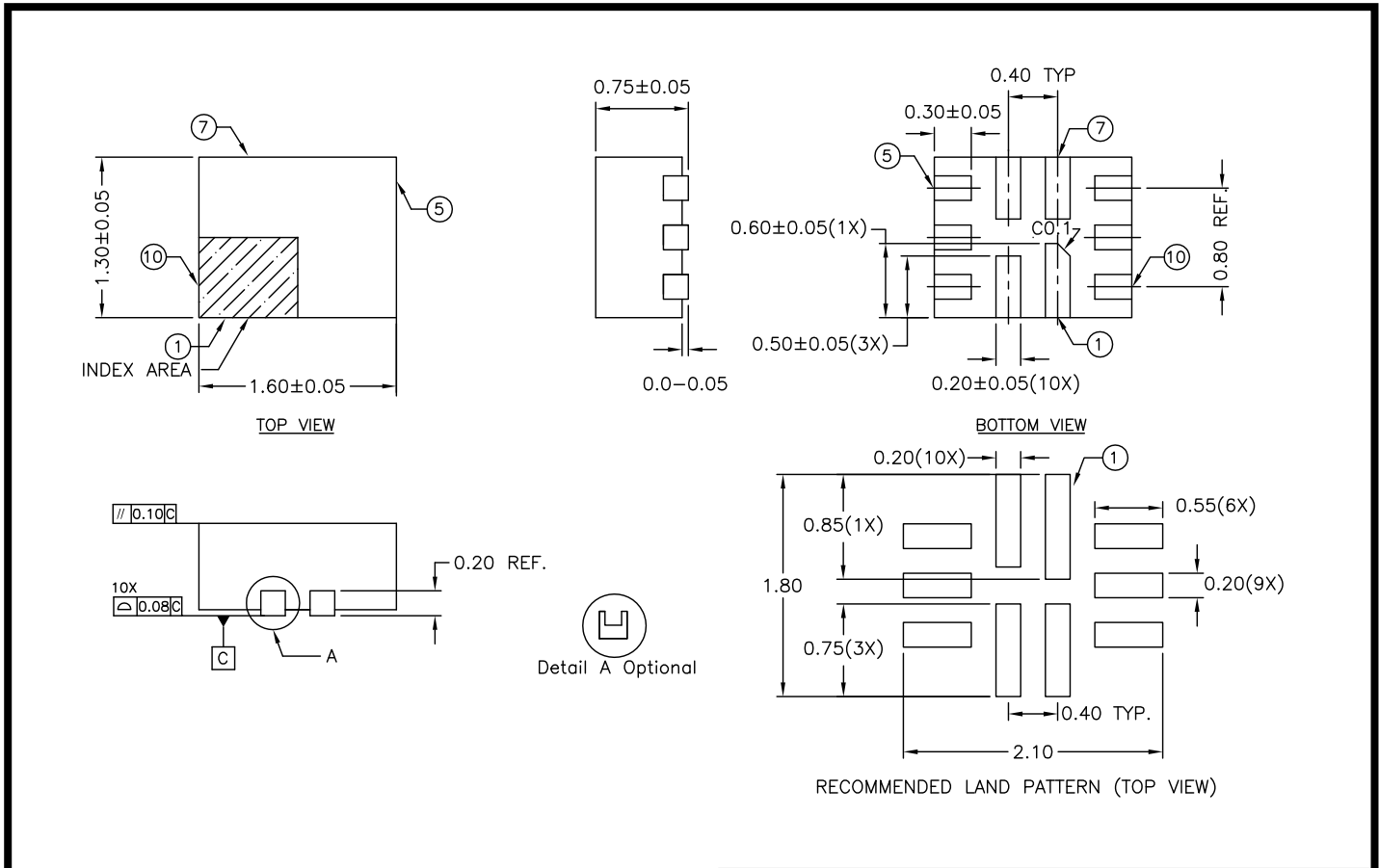

NOTE :

1. ALL DIMENSIONS ARE IN MILLIMETERS.
2. REFER MO-220.
3. RECOMMENDED LAND PATTERN IS FOR REFERENCE ONLY.

	DATE: 08/30/13
DESCRIPTION: 10-Contact, Thin Fine Pitch Quad Flat No-Lead (TQFN)	
PACKAGE CODE: ZL (ZL10)	
DOCUMENT CONTROL #: PD-2052	REVISION: E

13-0175

Note: For latest package info, please check: <http://www.pericom.com/support/packaging/packaging-mechanicals-and-thermal-characteristics/>

Ordering Information

Ordering Code	Package Code	Package Description	Top Mark
PI3USB103ZLEX	ZL	10-contact, Thin Fine Pitch Quad Flat No-Lead (TQFN), Tape & Reel	CW

Notes:

- Thermal characteristics can be found on the company web site at www.pericom.com/packaging/
- E = Pb-free and Green
- Adding X suffix = Tape/Reel

IMPORTANT NOTICE

DIODES INCORPORATED MAKES NO WARRANTY OF ANY KIND, EXPRESS OR IMPLIED, WITH REGARDS TO THIS DOCUMENT, INCLUDING, BUT NOT LIMITED TO, THE IMPLIED WARRANTIES OF MERCHANTABILITY AND FITNESS FOR A PARTICULAR PURPOSE (AND THEIR EQUIVALENTS UNDER THE LAWS OF ANY JURISDICTION).

Diodes Incorporated and its subsidiaries reserve the right to make modifications, enhancements, improvements, corrections or other changes without further notice to this document and any product described herein. Diodes Incorporated does not assume any liability arising out of the application or use of this document or any product described herein; neither does Diodes Incorporated convey any license under its patent or trademark rights, nor the rights of others. Any Customer or user of this document or products described herein in such applications shall assume all risks of such use and will agree to hold Diodes Incorporated and all the companies whose products are represented on Diodes Incorporated website, harmless against all damages.

Diodes Incorporated does not warrant or accept any liability whatsoever in respect of any products purchased through unauthorized sales channel.

Should Customers purchase or use Diodes Incorporated products for any unintended or unauthorized application, Customers shall indemnify and hold Diodes Incorporated and its representatives harmless against all claims, damages, expenses, and attorney fees arising out of, directly or indirectly, any claim of personal injury or death associated with such unintended or unauthorized application.

Products described herein may be covered by one or more United States, international or foreign patents pending. Product names and markings noted herein may also be covered by one or more United States, international or foreign trademarks.

This document is written in English but may be translated into multiple languages for reference. Only the English version of this document is the final and definitive format released by Diodes Incorporated.

LIFE SUPPORT

Diodes Incorporated products are specifically not authorized for use as critical components in life support devices or systems without the express written approval of the Chief Executive Officer of Diodes Incorporated. As used herein:

A. Life support devices or systems are devices or systems which:

1. are intended to implant into the body, or

2. support or sustain life and whose failure to perform when properly used in accordance with instructions for use provided in the labeling can be reasonably expected to result in significant injury to the user.

B. A critical component is any component in a life support device or system whose failure to perform can be reasonably expected to cause the failure of the life support device or to affect its safety or effectiveness.

Customers represent that they have all necessary expertise in the safety and regulatory ramifications of their life support devices or systems, and acknowledge and agree that they are solely responsible for all legal, regulatory and safety-related requirements concerning their products and any use of Diodes Incorporated products in such safety-critical, life support devices or systems, notwithstanding any devices- or systems-related information or support that may be provided by Diodes Incorporated. Further, Customers must fully indemnify Diodes Incorporated and its representatives against any damages arising out of the use of Diodes Incorporated products in such safety-critical, life support devices or systems.

Copyright © 2016, Diodes Incorporated

www.diodes.com

Mouser Electronics

Authorized Distributor

Click to View Pricing, Inventory, Delivery & Lifecycle Information:

[Diodes Incorporated:](#)

[PI3USB103ZLEX](#)