

Ultra Low Voltage Detectors

Features

- Low/High Threshold voltage with 90mV/100mV for PT7M6101 and 190mV/200mV for PT7M6102
- Internal Reference (10mV hysteresis)
- $\pm 10\text{mV}$ Threshold Voltage Accuracy Over Temperature
- Low Power Consumption: $8\mu\text{A}$ (typical)
- Three Output Configurations
 - Push-Pull Active Low-- $\overline{\text{OVRI}}$
 - Push-Pull Active High--- OVRI
 - Open-Drain Active Low--- $\overline{\text{OVRI}}$
- Guaranteed OVRI Valid to $V_{\text{CC}}=1.0\text{V}$
- Immune to Short Negative V_{CC} Transients
- SOT23-5L Package are available

Pin Configuration

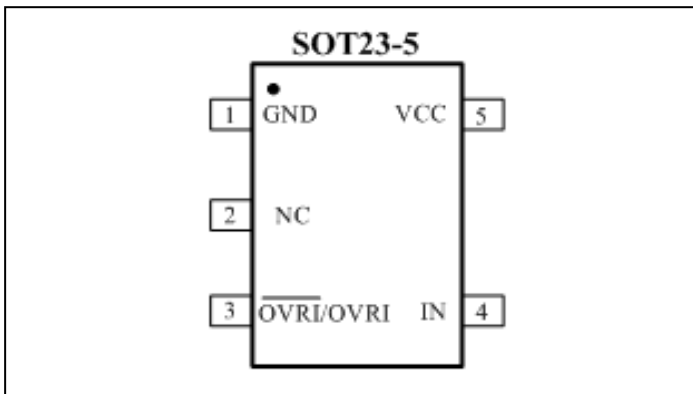

Description

PT7M6101/6102 series are designed for over current detector. They provide excellent circuit reliability and low cost by eliminating external components. These devices assert an OVRI signal when the voltage at IN pin rises above the high threshold. After IN pin declines below the low threshold, OVRI signal is de-asserted.

PT7M6101CL/6102CL have a push-pull active-low output. PT7M6101CH/6102CH have a push-pull active-high output. PT7M6101NL/6102NL have an open-drain active-low output. The open-drain active-low output requires a pull-up resistor that can be connected to a voltage higher than V_{DD} .

Low supply current of $8\mu\text{A}$ makes PT7M6101//6102 series ideal for using in battery power supply. These devices are available in SOT23-5 lead free packages.

Applications

- Over Current Protection in Battery Charger etc.
- Over Temperature Protection
- Power Supply
- Voltage Monitoring

Pin Description

Pin Name	I/O	Description
GND	GND	Ground
$\overline{\text{OVRI}}$	O	Over-current Output, Push-Pull or Open-Drain, Active-Low. OVRI changes from HIGH to LOW when IN rises above the typical high detection threshold (100mV). OVRI remains HIGH after IN drops below the low detection threshold (90mV).
OVRI	O	Over-current Output, Push-Pull, Active-High. OVRI changes from LOW to HIGH when IN rises above the typical high detection threshold (100mV). OVRI remains LOW after IN drops below the low detection threshold (90mV).
IN	I	Detection Voltage Input. High-impedance input for comparator. Connect this pin to over-current sampling network. OVRI is asserted when IN is above the high threshold voltage.
VCC	Power	Supply Voltage

Maximum Ratings

Storage Temperature.....	- 65°C to +150°C
Ambient Temperature with Power Applied.....	-40°C to +85°C
Supply Voltage to Ground Potential (V _{CC} to GND).....	- 0.3 to V _{CC} +6.0V
DC Input/Output Current20mA
Power Dissipation.....	.245mW

Note:

Stresses greater than those listed under MAXIMUM RATINGS may cause permanent damage to the device. This is a stress rating only and functional operation of the device at these or any other conditions above those indicated in the operational sections of this specification is not implied. Exposure to absolute maximum rating conditions for extended periods may affect reliability.

AC Electrical Characteristics

(V_{CC} = +0.9V to +5.5V, unless otherwise noted. Typical values are at T_A = +25 °C)

Description	Sym	Test Conditions	Min	Typ	Max	Unit
V _{CC} or RESET-IN to Reset Delay		IN rising, step signal from 0V to 1V	-	60	-	µs
Propagation Delay(D0 only)	t _p	IN falling, step signal from 1V to 0V	-	40	-	µs

DC Electrical Characteristics

(V_{CC} = +0.9V to +5.5V, unless otherwise noted. Typical values are at T_A = +25 °C)

Description	Sym	Test Conditions	Min	Typ	Max	Unit
Operating Voltage Range	V _{CC}	T _A = -40 °C ~+85 °C	0.9	-	5.5	V
Supply Current	I _{CC}	V _{CC} =1.2V, no load , reset not asserted	-	7.5	13	µA
		V _{CC} =1.8V, no load , reset not asserted	-	9	16	
		V _{CC} =3.6V, no load , reset not asserted	-	16	25	
IN Threshold	V _{RSTIN}	1.3V<=V _{CC} <=5.5V, -40 °C ~+85 °C (PT7M6101)	90	100	110	mV
		1.3V<=V _{CC} <=5.5V, -40 °C ~+85 °C (PT7M6102)	190	200	210	
Push-pull $\overline{\text{OVRI}}$ Output High Voltage	V _{OH}	V _{CC} >=1.1V, I _{source} =50 µA, reset not asserted	0.8×V _{CC}	-	-	-
		V _{CC} >=1.5V, I _{source} =150 µA, reset not asserted	0.8×V _{CC}	-	-	
		V _{CC} >=1.0V, I _{source} =50 µA, reset asserted	0.8×V _{CC}	-	-	
		V _{CC} >=1.5V, I _{source} =150 µA, reset asserted	0.8×V _{CC}	-	-	
Push-pull OVRI Output Low Voltage	V _{OL}	V _{CC} >=1.0V, I _{sink} =80 µA, reset asserted	-	-	0.2×V _{CC}	V
		V _{CC} >=1.5V, I _{sink} =200 µA, reset asserted	-	-	0.2×V _{CC}	
Push-pull $\overline{\text{OVRI}}$ Output Low Voltage		V _{CC} >=1.1V, I _{sink} =80 µA, reset not asserted	-	-	0.2×V _{CC}	
		V _{CC} >=1.5V, I _{sink} =200 µA, reset not asserted	-	-	0.2×V _{CC}	
Open-Drain $\overline{\text{OVRI}}$ Output Low Voltage		V _{CC} >=1.0V, I _{sink} =80 µA, reset asserted	-	-	0.15	V
		V _{CC} >=1.5V, I _{sink} =200 µA, reset asserted	-	-	0.2	
Open-Drain $\overline{\text{OVRI}}$ Output Leakage Current	I _{LKG}	V _{CC} > V _{TH} , reset not asserted	-	-	1.0	µA
IN Leakage Current	I _{RSTIN}	-	-25	-	+25	nA
Reset Threshold Hysteresis	V _{HYS}	-	-	10	-	mV

Block Diagram

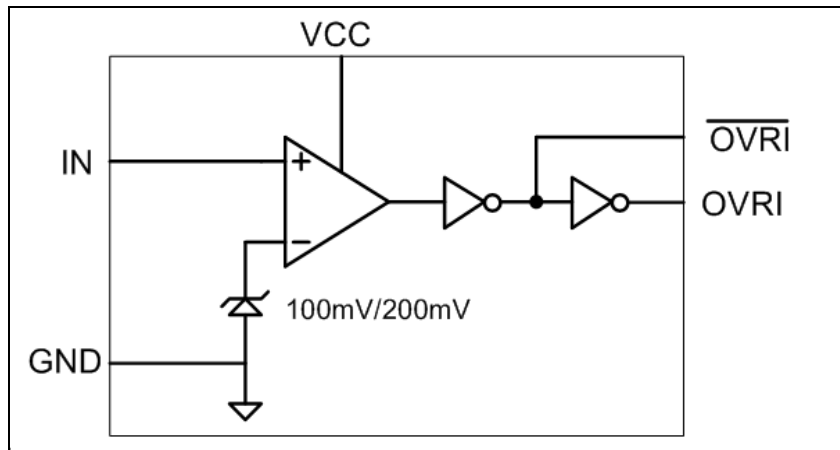

Functional Description

PT7M6101/6102 series are designed for over current detector. They provide excellent circuit reliability and low cost by eliminating external components. These devices assert an OVRI signal when the voltage at IN pin rises above the high threshold. After IN pin declines below the low threshold, OVRI signal is de-asserted.

Application Circuit

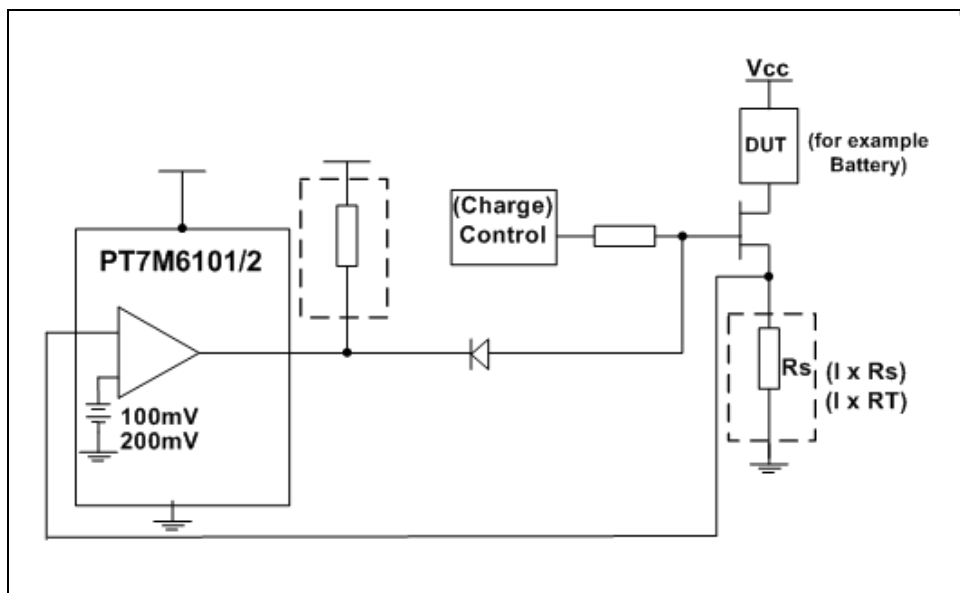
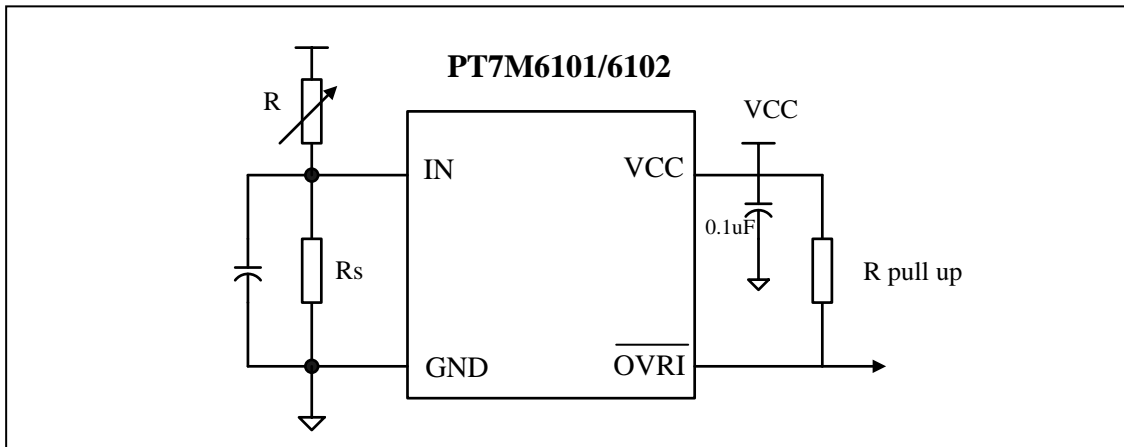

Mechanical Information

TA (SOT23-5L)

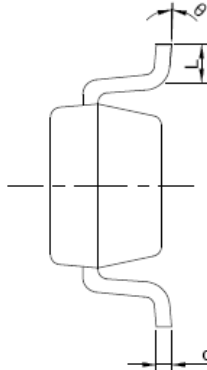
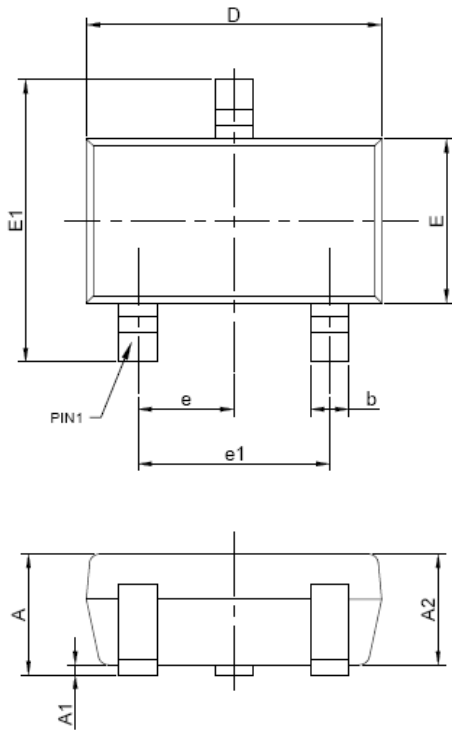

PKG. DIMENSIONS(MM)		
SYMBOL	Min	Max
A	1.05	1.25
A1	0.00	0.10
A2	1.06	1.15
b	0.30	0.50
c	0.10	0.20
D	2.82	3.02
E	1.50	1.70
E1	2.65	2.95
e	0.95 BSC	
e1	1.80	2.00
L	0.30	0.80
θ	0°	8°

Note:

1. Ref. JEDEC TO-236H



DATE: 06/19/13

DESCRIPTION: 3-Pin, Small Outline Transistor Plastic Package (SOT23)

PACKAGE CODE: TA (TA3)

DOCUMENT CONTROL #: PD-2143

REVISION: --

Ordering Information

Part Number	Package Code	Package
PT7M610xCLTAE	TA	Lead free and Green SOT23-5L
PT7M610xCHTAE	TA	Leas free and Green SOT23-5L
PT7M610xNLTAE	TA	Lead free and Green SOT23-5L

Note:

- Suffix “x” shows 1 or 2 with different function. See Table 1
- E = Pb-free and Green
- Adding X Suffix= Tape/Reel
- Contact Pericom for availability

Table 1 Part No code comparison table

No.	Part No.	Code
1	PT7M6101CL	jp
2	PT7M6101CH	jq
3	PT7M6101NL	jl
4	PT7M6102CL	rz
5	PT7M6102CH	sa
6	PT7M6102NL	sb

Function comparison of PT7M6101/6102

No	Part No.	Output Open-Drain		Output Push-Pull	
		Active high	Active low	Active high	Active low
1	PT7M6101CL/6102CL	-	-	-	√
2	PT7M6101CH/6102CH	-	-	√	-
3	PT7M6101NL/6102NL	-	√	-	-

Pericom Semiconductor Corporation • 1-800-435-2336 • www.pericom.com

Pericom reserves the right to make changes to its products or specifications at any time, without notice, in order to improve design or performance and to supply the best possible product. Pericom does not assume any responsibility for use of any circuitry described other than the circuitry embodied in Pericom product. The company makes no representations that circuitry described herein is free from patent infringement or other rights, of Pericom.

Mouser Electronics

Authorized Distributor

Click to View Pricing, Inventory, Delivery & Lifecycle Information:

Diodes Incorporated:

[PT7M7433TAEX](#) [PT7M7809RTEX](#) [PT7M7809STEX](#) [PT7M7809ZTEX](#) [PT7M7809TTEX](#) [PT7M7810STEX](#)
[PT7M7824RTAEX](#) [PT7M6709OUE](#) [PT7M6834ID3TA3EX](#) [PT7M7823STAEX](#) [PT7M7435TAEX](#) [PT7M6834WD1C3EX](#)
[PT7M7437TAEX](#) [PT7M7811TTAEX](#) [PT7M7824STAEX](#) [PT7M7825STAEX](#) [PT7M6714CUE](#) [PT7M7825LTAEX](#)
[PT7M6709OUEX](#) [PT7M7824TTAEX](#) [PT7M7810TTEX](#) [PT7M7803STEX](#) [PT7M7823RTAEX](#) [PT7M6832VD3TA3EX](#)
[PT7M6429CHTA5EX](#) [PT7M6428CHTA5EX](#) [PT7M6433CHTA5EX](#) [PT7M6431CHTA5EX](#) [PT7M6430CHTA5EX](#)
[PT7M6426CLTA5EX](#) [PT7M6427CHTA5EX](#) [PT7M6432CHTA5EX](#) [PT7M7810LTEX](#) [PT7M7809JTEX](#)
[PT7M7811TTBEX](#) [PT7M7811MTBEX](#) [PT7M7825RTAEX](#) [PT7M6832VD3C3EX](#) [PT7M6834WD3TA3EX](#)
[PT7M6433CHTA3EX](#) [PT7M6427CLTA3EX](#) [PT7M6431CHTA3EX](#) [PT7M6430CHTA3EX](#) [PT7M6427CHTA3EX](#)
[PT7M6529NLTA5EX](#) [PT7M6432CHTA3EX](#) [PT7M6428CHTA3EX](#) [PT7M6430CLTA3EX](#) [PT7M6429CHTA3EX](#)
[PT7M6530NLXVEX](#) [PT7M6530NLTA5EX](#) [PT7M6430NLTA3EX](#) [PT7M6426CLTA3EX](#) [PT7M6834ID3TAEX](#)