



eZ80L925148MODG

eZ80L92 Module

Product Specification

PS031802-0514

PRELIMINARY

The logo for eZ80 Acclaim!™ Flash Microcontrollers. The "eZ80" is in a large, bold, yellow font with a black outline. "Acclaim!" is in a bold, black font with a trademark symbol. Below it, "Flash Microcontrollers" is written in a smaller, italicized black font.



Warning: DO NOT USE THIS PRODUCT IN LIFE SUPPORT SYSTEMS.

LIFE SUPPORT POLICY

ZILOG'S PRODUCTS ARE NOT AUTHORIZED FOR USE AS CRITICAL COMPONENTS IN LIFE SUPPORT DEVICES OR SYSTEMS WITHOUT THE EXPRESS PRIOR WRITTEN APPROVAL OF THE PRESIDENT AND GENERAL COUNSEL OF ZILOG CORPORATION.

As used herein

Life support devices or systems are devices which (a) are intended for surgical implant into the body, or (b) support or sustain life and whose failure to perform when properly used in accordance with instructions for use provided in the labeling can be reasonably expected to result in a significant injury to the user. A critical component is any component in a life support device or system whose failure to perform can be reasonably expected to cause the failure of the life support device or system or to affect its safety or effectiveness.

Document Disclaimer

©2014 Zilog, Inc. All rights reserved. Information in this publication concerning the devices, applications, or technology described is intended to suggest possible uses and may be superseded. ZILOG, INC. DOES NOT ASSUME LIABILITY FOR OR PROVIDE A REPRESENTATION OF ACCURACY OF THE INFORMATION, DEVICES, OR TECHNOLOGY DESCRIBED IN THIS DOCUMENT. ZILOG ALSO DOES NOT ASSUME LIABILITY FOR INTELLECTUAL PROPERTY INFRINGEMENT RELATED IN ANY MANNER TO USE OF INFORMATION, DEVICES, OR TECHNOLOGY DESCRIBED HEREIN OR OTHERWISE. The information contained within this document has been verified according to the general principles of electrical and mechanical engineering.

eZ80, eZ80Acclaim!, and eZ80Acclaim*Plus!* are trademarks or registered trademarks of Zilog, Inc. All other product or service names are the property of their respective owners.

Revision History

Each instance in this document's revision history reflects a change from its previous edition. For more details, refer to the corresponding page(s) or appropriate links furnished in the following table.

Date	Revision Level	Description	Page
May 2014	02	Updated Figure 8 schematic diagram to correct PD4 resistor from pull-up to pull-down.	20
Oct 2013	01	Original Zilog issue.	All

Table of Contents

Revision History	iii
List of Figures	v
List of Tables	vi
The eZ80L92 Module	1
Module Features	1
eZ80L92 Processor Features	2
Block Diagram	2
Pin Description	4
Peripheral Bus Connector	4
I/O Connector	7
Onboard Component Description	11
Logic-Level I/Os	11
Onboard Battery Backup	11
Ethernet Media Access Controller	11
Ethernet LEDs	11
Ethernet Connectors	12
GPIO Pins for Enabling LAN Activity, Sleep, Interrupt	12
EMAC Ports	13
EMAC Wait States	13
Memory	13
Wait States	13
Static RAM	13
Flash Memory	14
Reset Generator	14
Serial Interface Ports	14
Physical Dimensions	15
Mounting the Module onto the eZ80 [®] Development Platform	16
ESD/EMI Protection	17
Absolute Maximum Ratings	18
Power Supply	18
Schematic Diagrams	20
Customer Support	24

List of Figures

Figure 1.	eZ80L92 Module Functional Block Diagram	3
Figure 2.	eZ80L92 Module Peripheral Bus Connector Pin Configuration	4
Figure 3.	eZ80L92 Module I/O Connector Pin Configuration	7
Figure 4.	Dimension Drawing	15
Figure 5.	Top View	16
Figure 6.	Mounting Examples	17
Figure 7.	Power Supply Examples	19
Figure 8.	eZ80L92 Module Schematic Diagram, #1 of 4: EMAC and Ethernet Connections	20
Figure 9.	eZ80L92 Module Schematic Diagram, #2 of 4: Memory	21
Figure 10.	eZ80L92 Module Schematic Diagram, #3 of 4: eZ80L92 Device	22
Figure 11.	eZ80L92 Module Schematic Diagram, #4 of 4: Interfaces	23

List of Tables

Table 1.	eZ80L92 Module Peripheral Bus Connector Pin Identification	5
Table 2.	eZ80L92 Module I/O Connector Pin Identification	8
Table 3.	Ethernet Connector Pin Assignments	12
Table 4.	Chip Frequency to Wait State Cycle Time Calculation	13
Table 5.	Absolute Maximum Ratings	18

The eZ80L92 Module

The eZ80L92 Module is a compact, high-performance Ethernet module specially designed for the rapid development and deployment of embedded systems requiring control and Internet/Intranet connectivity.

This low-cost, expandable module is powered by Zilog's power-efficient, high-speed, optimized pipeline architecture eZ80L92 device (eZ80L925048MOD), a member of Zilog's eZ80[®] microprocessor family.

The eZ80L92 microprocessor is a high-speed single-cycle instruction-fetch microprocessor, which can operate with a clock speed of 48MHz. It can operate in Z80-compatible addressing mode (64KB) or full 24-bit addressing mode (16MB).

The rich peripheral set of the eZ80L92 Module makes it suitable for a variety of applications, including industrial control, IrDA connectivity, communication, security, automation, point-of-sale terminals, and embedded networking applications.

Module Features

- eZ80L92 MPU default factory operating clock frequency at 48MHz
- 10Base-T Ethernet Media Access Controller+ PHI with on-board RJ45 connector
- 512KB zero-wait-state on-board SRAM
- 8MB on-board NOR Flash ROM (90–100ns)
- GoldCap backup for Real-Time Clock
- I/O connector provides 24 general-purpose 5 V-tolerant I/O pinouts
- On-board connector provides I²C 2-wire SDA/SCL interface
- On-board connector provides I/O bus for external peripheral connections (IRQ, \overline{CS} , 24 address, 8 data)
- Low-cost connection to carrier board via two 2x25pin (2.54mm) headers
- Horizontal or vertical mounting onto the eZ80[®] Development Platform
- Small footprint 64x64mm; height is 24mm
- 3.3 V power supply
- Standard operating temperature range: 0°C to +70°C

eZ80L92 Processor Features

- Single-cycle instruction fetch, high-performance, pipelined eZ80[®] CPU core
- Low power features including Sleep Mode, Halt Mode, and selective peripheral power-down control
- Two UARTs with independent baud rate generators
- SPI with independent clock rate generator
- I²C with independent clock rate generator
- Infrared Data Association (IrDA)-compliant infrared encoder/decoder
- New DMA-like eZ80[®] instructions for efficient block data transfer
- Glueless external memory interface with 4 chip selects, individual wait state generators, and an external WAIT input pin: supports Intel- and Motorola-style buses
- Fixed-priority vectored interrupts (both internal and external) and interrupt controller
- Real-time clock with on-chip 32KHz oscillator, selectable 50/60Hz input, and separate V_{DD} pin for battery backup
- Six 16-bit Counter/Timers with prescalers and direct input/output drive
- Watch-Dog Timer
- 24 bits of general-purpose I/O
- JTAG and ZDI debug interfaces
- 100-pin LQFP package
- 3.0–3.6V supply voltage with 5V tolerant inputs
- Standard operating temperature range: 0°C to +70°C

► **Note:** All signals with an overline are active Low. For example, B/W, for which WORD is active Low, and B/W, for which BYTE is active Low.

Block Diagram

Figure 1 illustrates a block diagram of the eZ80L92 Module.

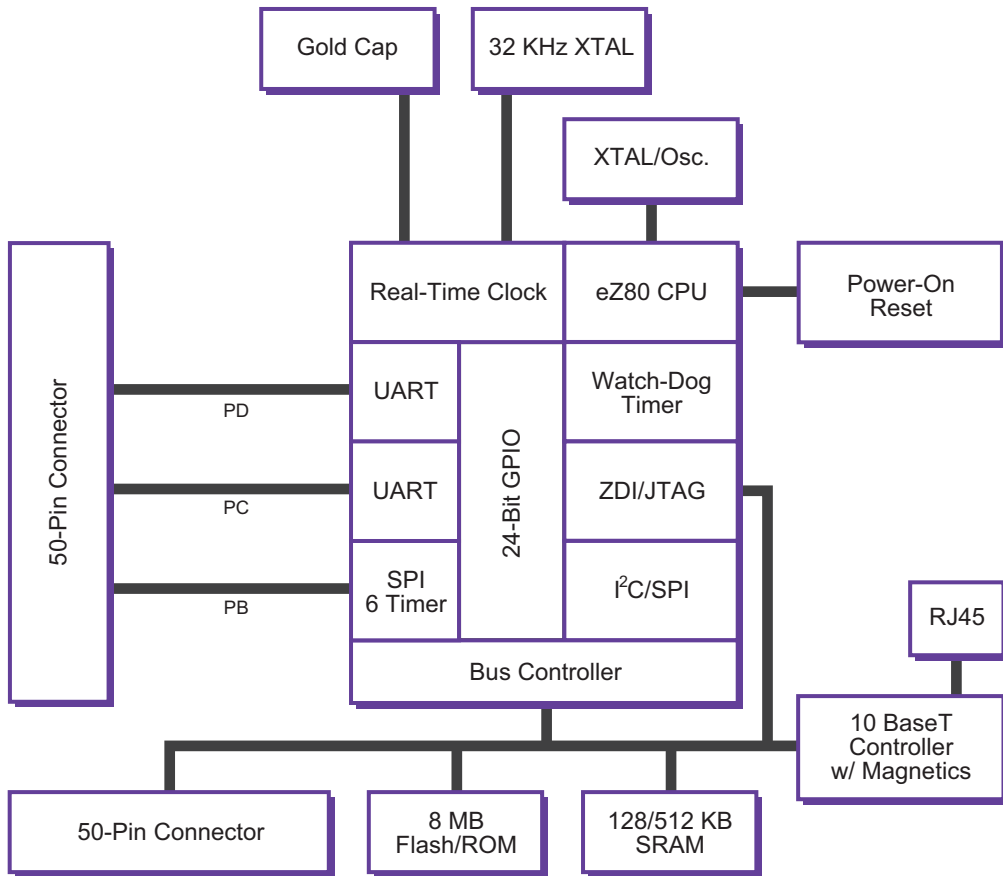

Figure 1. eZ80L92 Module Functional Block Diagram

Pin Description

Peripheral Bus Connector

Figure 2 illustrates the pin layout of the 50-pin I/O Connector, located at position JP1 on the eZ80L92 Module. Table 6 describes the pins and their functions.

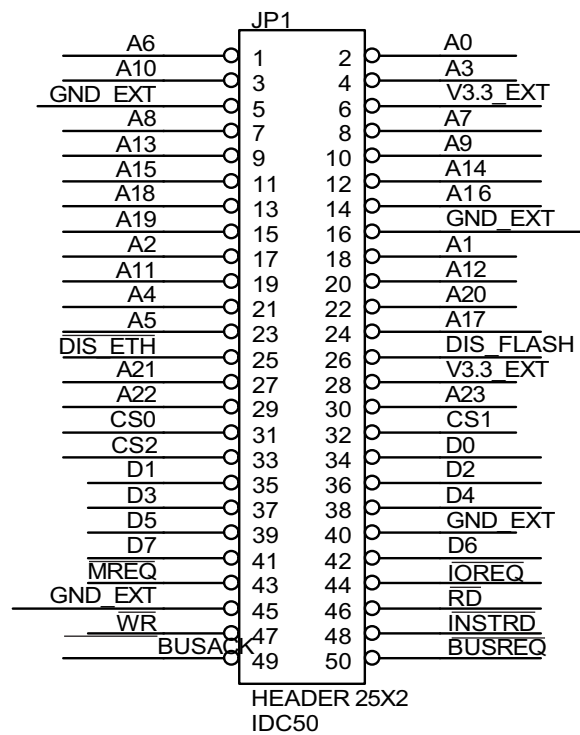

Figure 2. eZ80L92 Module Peripheral Bus Connector Pin Configuration

Table 6. eZ80L92 Module Peripheral Bus Connector Pin Identification*

Pin #	Symbol	Pull Up/Down*	Signal Direction	Comments
1	A6		Bidirectional	
2	A0		Bidirectional	
3	A10		Bidirectional	
4	A3		Bidirectional	
5	GND			V _{SS} /Ground (0V).
6	V _{DD}			3.3V Supply Input Pin.
7	A8		Bidirectional	
8	A7		Bidirectional	
9	A13		Bidirectional	
10	A9		Bidirectional	
11	A15		Bidirectional	
12	A14		Bidirectional	
13	A18		Bidirectional	
14	A16		Bidirectional	
15	A19		Bidirectional	
16	GND			V _{SS} /Ground (0V).
17	A2		Bidirectional	
18	A1		Bidirectional	
19	A11		Bidirectional	
20	A12		Bidirectional	
21	A4		Bidirectional	
22	A20		Bidirectional	
23	A5		Bidirectional	
24	A17		Bidirectional	
25	DIS_Eth	PU 10K ^{3/4}	Input	A Low disables on-module EMAC from responding to CS3 on a per-cycle basis. CS3 can be used on the eZ80 [®] Development Platform; CMOS Input 3.3V (5V tolerant)

Notes: *External capacitive loads on RD, WR, IORQ, MREQ, D0–D7 and A0–A23 should be below 10pF to satisfy timing requirements for the eZ80[®] CPU.
 All unused inputs should be pulled to either V_{DD} or GND, depending on their inactive levels to reduce power consumption and to reduce noise sensitivity.
 To prevent EMI, the EZ80CLK output can be deactivated via software in the eZ80L92 Peripheral Power-Down Register.
 All inputs are CMOS level 3.3V (5V tolerant), except where otherwise noted.

Table 6. eZ80L92 Module Peripheral Bus Connector Pin Identification* (Continued)

Pin #	Symbol	Pull Up/Down*	Signal Direction	Comments
26	DIS_Flash	PU 10K ^{3/4}	Input	A Low disables on-module Flash memory from responding to CS0 on a per-cycle basis. CS0 can be used on the eZ80 [®] Development Platform for external memory purposes; CMOS Input 3.3V (5V tolerant).
27	A21		Bidirectional	
28	V _{DD}			3.3V supply input pin.
29	A22		Bidirectional	
30	A23		Bidirectional	
31	CS0		Output	
32	CS1		Output	
33	CS2		Output	
34	D0	PU 4k7 ^{3/4}	Bidirectional	
35	D1	PU 4k7 ^{3/4}	Bidirectional	
36	D2	PU 4k7 ^{3/4}	Bidirectional	
37	D3	PU 4k7 ^{3/4}	Bidirectional	
38	D4	PU 4k7 ^{3/4}	Bidirectional	
39	D5	PU 4k7 ^{3/4}	Bidirectional	
40	GND			V _{SS} /Ground (0V).
41	D7	PU 4k7 ^{3/4}	Bidirectional	
42	D6		Bidirectional	
43	MREQ		Bidirectional	
44	IORQ		Bidirectional	
45	GND			V _{SS} /Ground (0V).
46	RD		Bidirectional	
47	WR		Bidirectional	
48	INSTRD		Output	
49	BUSACK	PU 10K ^{3/4}	Output	
50	BUSREQ	PU 10K ^{3/4}	Input	

Notes: *External capacitive loads on RD, WR, IORQ, MREQ, D0–D7 and A0–A23 should be below 10pF to satisfy timing requirements for the eZ80[®] CPU.

All unused inputs should be pulled to either V_{DD} or GND, depending on their inactive levels to reduce power consumption and to reduce noise sensitivity.

To prevent EMI, the EZ80CLK output can be deactivated via software in the eZ80L92 Peripheral Power-Down Register.

All inputs are CMOS level 3.3V (5V tolerant), except where otherwise noted.

I/O Connector

Figure 3 illustrates the pin layout of the 50-pin I/O Connector, located at position JP2 of the eZ80L92 Module. Table 7 describes the pins and their functions.

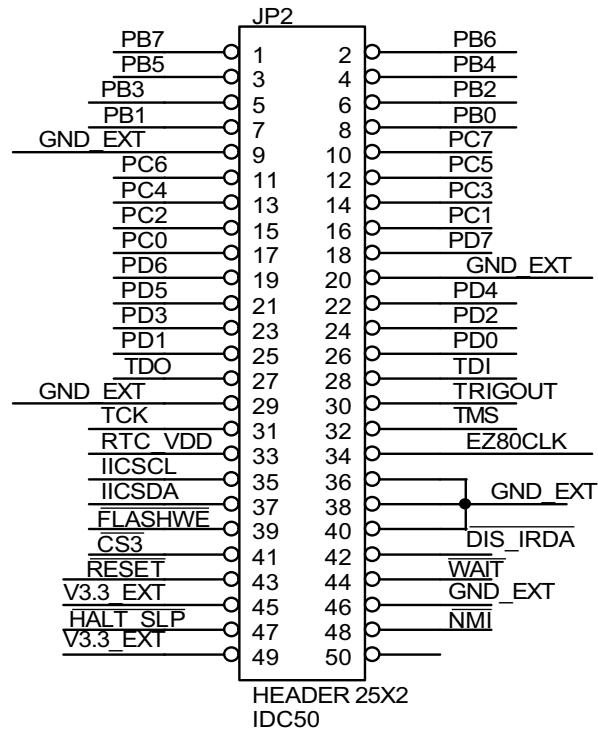

Figure 3. eZ80L92 Module I/O Connector Pin Configuration

Table 7. eZ80L92 Module I/O Connector Pin Identification*

Pin #	Symbol	Pull Up/Down	Signal Direction	Comments
1	PB7		Bidirectional	
2	PB6		Bidirectional	
3	PB5		Bidirectional	
4	PB4		Bidirectional	
5	PB3		Bidirectional	
6	PB2		Bidirectional	
7	PB1		Bidirectional	
8	PB0		Bidirectional	
9	GND			V _{SS} /Ground (0V).
10	PC7		Bidirectional	
11	PC6		Bidirectional	
12	PC5		Bidirectional	
13	PC4		Bidirectional	
14	PC3		Bidirectional	
15	PC2		Bidirectional	
16	PC1		Bidirectional	
17	PC0		Bidirectional	
18	PD7		Bidirectional	
19	PD6		Bidirectional	
20	GND			V _{SS} /Ground (0V).
21	PD5		Bidirectional	
22	PD4	PD 4k7	Bidirectional	
23	PD3		Bidirectional	
24	PD2		Bidirectional	
25	PD1		Bidirectional	
26	PD0		Bidirectional	
27	TDO		Output	JTAG data output pin.
28	TDI/ZDA	PU 10K ^{3/4}	Input	JTAG data input pin.
29	GND			V _{SS} /Ground (0V).

Notes: *External capacitive loads on \overline{RD} , \overline{WR} , \overline{IORQ} , \overline{MREQ} , D0–D7 and A0–A23 should be below 10pF to satisfy timing requirements for the CPU. All unused inputs should be pulled to either V_{DD} or GND, depending on their inactive levels, to reduce power consumption and to reduce noise sensitivity. To prevent EMI, the EZ80CLK output can be deactivated via software in the eZ80F91 Peripheral Power-Down Register. All inputs are CMOS level 3.3V (5V tolerant), except where otherwise noted.

Table 7. eZ80L92 Module I/O Connector Pin Identification* (Continued)

Pin #	Symbol	Pull Up/Down	Signal Direction	Comments
30	TRIGOUT		Output	Active High trigger event indicator.
31	TCK/ZCL	PU 10K ^{3/4}	Input	JTAG clock. High on reset enables ZDI mode; Low on reset enables OCI debug.
32	TMS	PU 10K ^{3/4}	Input	JTAG Test Mode Select.
33	RTC_V _{DD}			RTC supply from GoldCap (or external battery).
34	EZ80CLK		Output	48MHz synchronous CPU clock.
35	SCL	PU 4k7	Bidirectional	I ² C Bus Clock.
36	GND			V _{SS} /Ground (0V).
37	SDA	PU 4k7	Bidirectional	I ² C Bus Data.
38	GND			V _{SS} /Ground (0V).
39	FlashWE	PU 10K ^{3/4}	Input	Low enables Write to on-board Flash memory. If this pin is unconnected, the Flash memory is write-protected.
40	GND			V _{SS} /Ground (0V).
41	CS ₃		Output	Used on module for CS8900 EMAC.
42	DIS_IRDA	PU 10K ^{3/4}	Input	Low disables on-board IRDA transceiver to use PD0/PD1 UART pins externally.
43	RESET	PU 2k2	Bidirectional	Reset output from Module or push-button reset.
44	WAIT	PU 2k2	Input	Driving the WAIT pin Low forces the eZ80 [®] CPU to provide additional clock cycles for an external peripheral or external memory to complete its Read or Write operation.
45	V _{DD}			3.3V supply input pin.

Notes: *External capacitive loads on \overline{RD} , \overline{WR} , \overline{IORQ} , \overline{MREQ} , D0–D7 and A0–A23 should be below 10pF to satisfy timing requirements for the CPU. All unused inputs should be pulled to either V_{DD} or GND, depending on their inactive levels, to reduce power consumption and to reduce noise sensitivity. To prevent EMI, the EZ80CLK output can be deactivated via software in the eZ80F91 Peripheral Power-Down Register. All inputs are CMOS level 3.3V (5V tolerant), except where otherwise noted.

Table 7. eZ80L92 Module I/O Connector Pin Identification* (Continued)

Pin #	Symbol	Pull Up/Down	Signal Direction	Comments
46	GND			V_{SS} /Ground (0V).
47	HALT_SLP		Output, Active Low	A Low on this pin indicates that the eZ80 [®] CPU enters either Halt or Sleep modes because of execution of either a HALT or SLP instruction.
48	NMI	PU 10K ^{3/4}	Schmitt Trigger Input, Active Low	The $\overline{\text{NMI}}$ input is a higher priority input than the maskable interrupts. It is always recognized at the end of an instruction, regardless of the state of the interrupt enable control bits. This input includes a Schmitt trigger to allow RC rise times. This external $\overline{\text{NMI}}$ signal is combined with an internal $\overline{\text{NMI}}$ signal generated from the WDT block before being connected to the $\overline{\text{NMI}}$ input of the eZ80 [®] CPU.
49	V_{DD}			3.3V supply input pin.
50	Reserved		NC	Reserved; No Connection.

Notes: *External capacitive loads on $\overline{\text{RD}}$, $\overline{\text{WR}}$, $\overline{\text{IORQ}}$, $\overline{\text{MREQ}}$, D0–D7 and A0–A23 should be below 10pF to satisfy timing requirements for the CPU. All unused inputs should be pulled to either V_{DD} or GND, depending on their inactive levels, to reduce power consumption and to reduce noise sensitivity. To prevent EMI, the EZ80CLK output can be deactivated via software in the eZ80F91 Peripheral Power-Down Register. All inputs are CMOS level 3.3V (5V tolerant), except where otherwise noted.

On-Board Component Description

Logic-Level I/Os

The I/O connector features 24 general-purpose 3.3V CMOS I/O pins that can be used as outputs or inputs interfacing to external logic. All I/Os are 5V tolerant. Some of the General-Purpose I/O pins support dual mode functions (SPI, Timer I/O, UARTs and bit I/O with edge- or level-triggered interrupt functions on each pin). For more information on eZ80L92 dual modes, please refer to the [eZ80L92 Product Specification \(PS0130\)](#).

On-Board Battery Backup

An on-board 0.1F capacitor (GoldCap) is used to bridge power outages of 2–4 hours if the power supply to the module is disconnected. The capacitor is charged to 3.1V during normal operation and is discharged through the on-chip Real Time Clock. The V_{RTC} pin is available on the I/O connector of the module to connect external components to a power supply or to a larger GoldCap.



Caution: Do not connect a Lithium Battery to the GoldCap capacitor, because on-board charging circuitry for the capacitor can destroy the lithium battery.

Ethernet Media Access Controller

The eZ80L92 Module contains a CS8900A EMAC (MAC, PHI, and RAM) which is attached to the data/address bus of the processor. This chip is connected to the processor's CS3 Chip Select, A0–A3, D0–D7, \overline{RD} , \overline{WR} , and PD4 pins for interrupt purposes. The connection of the PD6 and PD7 pins for LANACT (i.e., wake-up from sleep) and Sleep is optional and resistor-selectable onboard; see the Ethernet Connectors section that follows to learn more.

Ethernet LEDs

Two LEDs are embedded in the RJ45 connector. When facing the connector, the GREEN LED is located on the left side, and the YELLOW LED is located on the right. The GREEN LED is active when the module transmits or receives a frame, or when it detects a collision. The YELLOW LED is active when the module receives a valid 10 Base-T link pulse; it is, essentially an indicator of an established link.

Ethernet Connectors

The eZ80L92 Module is equipped with an RJ45 connector that features integrated magnetics (transformer, common mode chokes, and LEDs). The remaining pins on the on-board RJ45 connector are not connected.

Node assignments for the RJ45 Ethernet connector are shown in Table 8.

Table 8. Ethernet Connector Pin Assignments

Pin	Function
1	TX+
2	TX-
3	RX+
6	RX-

Node assignment, in contrast to hub assignment, means that a straight-through cable (equivalent pin numbers on both sides of the cable are connected to each other) is used to attach the board to an Ethernet hub or switch. To connect the eZ80L92 Module directly to another node (e.g., a personal computer), a crossover cable must be used.

The EMAC can be additionally protected by placing a U2 ESD protection array on the module. This array can be either of the LCDA15C-6 (Semtech) or ESDA25B1 (ST Microelectronics) devices.

GPIO Pins for Enabling LAN Activity, Sleep, Interrupt

GPIO input bit PD4 serves as an active High interrupt input for the EMAC's INTRQ0 output.

GPIO output bit PD7 can be used to enter the EMAC into Sleep Mode. When pulling Sleep (PD7) Low after enabling HWStandbyE and HWSleepE modes, the chip draws lower current, because only the receiver is operating. A zero-Ohm resistor at position R6 on the eZ80L92 Module is required for this function. In this case, the PD6 pin is not available for GPIO on the I/O connector.

If LAN activity is detected, the LANACT signal is pulled Low. The LANACT is connected to GPIO input PD6 and can be used in interrupt edge-detection mode to wake up and reinitialize the Ethernet chip. A zero-Ohm resistor at position R3 on the module is required for this function. In this case, the PD6 pin is not available for GPIO on the I/O connector.

EMAC Ports

Chip Select CS3 is used for selecting the EMAC via I/O decoding. The I/O base address is user-selectable. The EMAC is connected as an 8- or 16-bit device with 8-word-wide I/O registers:

EMAC Wait States

The CS8900A EMAC should be operated in Intel bus mode so that the setup and hold times for the I/O access are met. For 48MHz operation, first set CS3_BMC (I/O address 0xF3h) to 84h (Intel bus mode with four system clock cycles per bus cycle) and then CS3_CTL (I/O Address 0xB3) to 18h (0 wait states for I/O). For a 20.8ns CPU Clock cycle time, the Read and Write access time is:

$$2 \times 4 \times 20.8\text{ns} - 16\text{ns (for capacitive and chip delays)} = 150\text{ns}$$

Memory

The eZ80L92 Module offers SRAM and Flash memories and the wait states that support memory operations, as described in this section.

Wait States

To ensure that valid data is read from or written to slower memories, a number of wait states must be inserted into the memory or I/O access operations by the processor. The number of wait states that are required should be added by programming the chip select control registers. To calculate the minimum number of wait states required, refer to Table 9.

Table 9. Chip Frequency to Wait State Cycle Time Calculation

MHz	Cycle Time
12	83.3ns
20	50.0ns
24	41.7ns
36	27.8ns
40	25.0ns
48	20.8ns

Static RAM

The eZ80L92 Module features 512KB of fast SRAM. Access speed is typically 12ns or faster, allowing zero-wait-state operation at 48MHz. With the CPU at 48MHz, on-board

SRAM can be accessed with zero wait states in eZ80 mode. CS1_CTL (chip select $\overline{\text{CS1}}$) can be set to 08h (no wait states).

Flash Memory

The Flash Boot Loader, application code, and user configuration data are held permanently in NOR Flash memory. A typical application requires eight times more ROM for code than RAM. As an example, for 128KB on-board SRAM, 1MB of ROM is required. The eZ80L92 Module allows NOR Flash memories between 4 megabits (512KB) and 64 megabits (8MB) to be used. The chips are housed in wide TSOP40 cases. Flash ROM access times are 55–150ns; typically 90ns.

NOR Flash should be operated in Intel bus mode to satisfy setup and hold times and to prevent bus contention with a Write cycle that could possibly follow. For proper CPU operation at 48MHz, first set the bus mode control register CS0_BMC (I/O address 0xF0h) to 82h, then set the Chip Select Control register CS0_CTL (I/O address 0xAAh) to 08h. These settings select Intel Bus Mode with two system clocks per bus cycle and zero wait states.

Reset Generator

The on-board Reset Generator Chip performs reliable Power-On Reset. The chip generates a reset pulse with a duration of 200ms if the power supply drops below 2.93V. This reset pulse ensures that the board always starts in a defined condition. The RESET pin on the I/O connector reflects the status of the RESET line. It is a bidirectional pin for resetting external peripheral components or for resetting the eZ80L92 Module with a low-impedance output (e.g. a 100-Ohm pushbutton).

Serial Interface Ports

The processor contains two 16550-style UARTs with programmable baud rate generators. UART0 is typically used for console I/O and initial boot code upload or to connect remote peripherals that can be controlled and monitored via Ethernet. UART0 is connected to GPIO PD[0:3] on the I/O connector. There are no RS232-level shifters on the eZ80L92 Module.

► **Note:** Do not connect an RS-232 interface without level shifters.

UART1 can be used for modem attachment or as a communications port to a host computer, where the embedded Ethernet module emulates an AT-style modem for internet access. UART1 does not offer on-board RS232-level shifters.

Physical Dimensions

The size of the eZ80L92 Module PCB is 64x64mm. With an RJ45 Ethernet connector, the overall height is 25 mm, as shown in Figure 4.

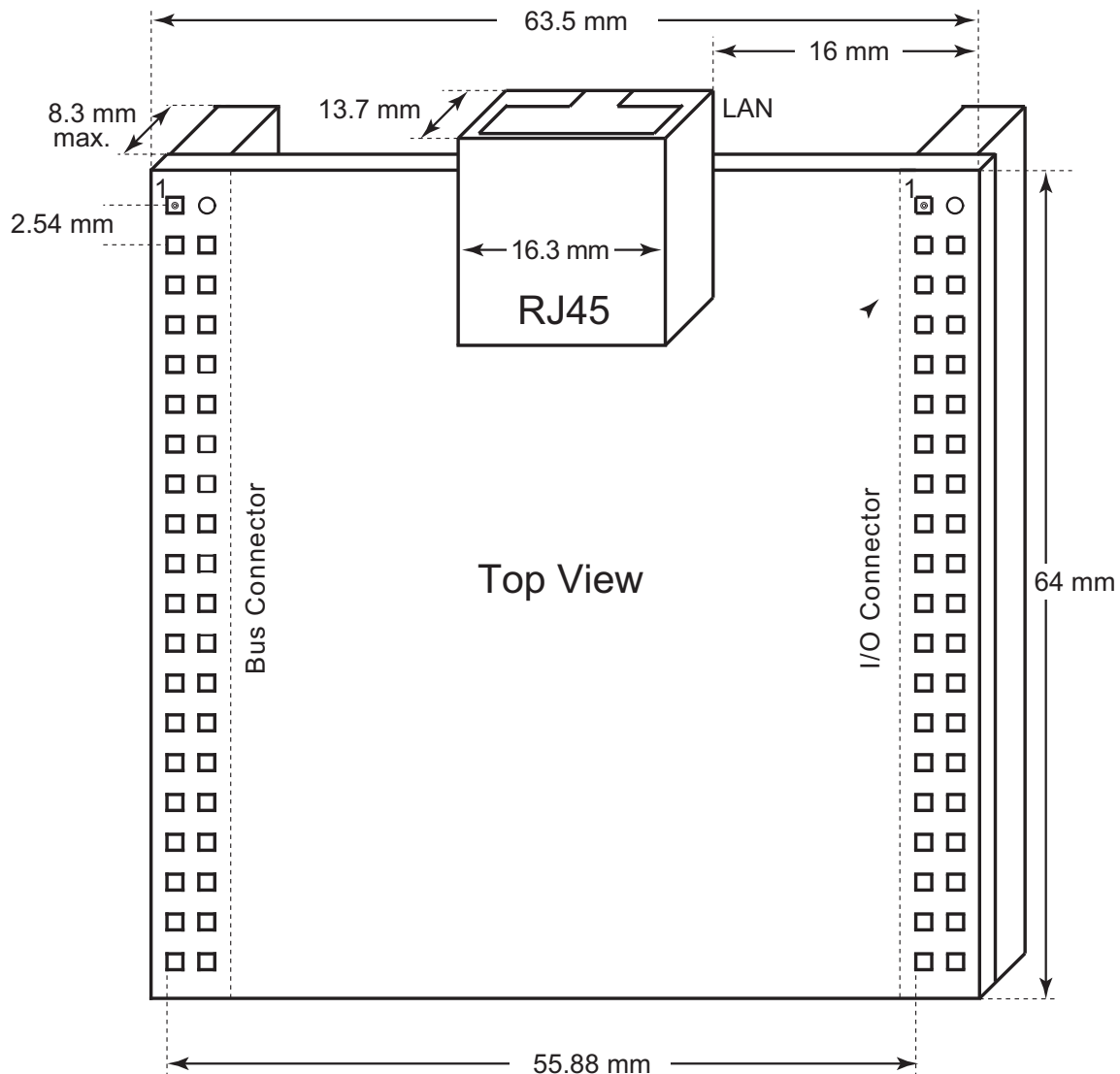

Figure 4. Dimension Drawing

Figure 5 illustrates a top view of the eZ80L92 Module.

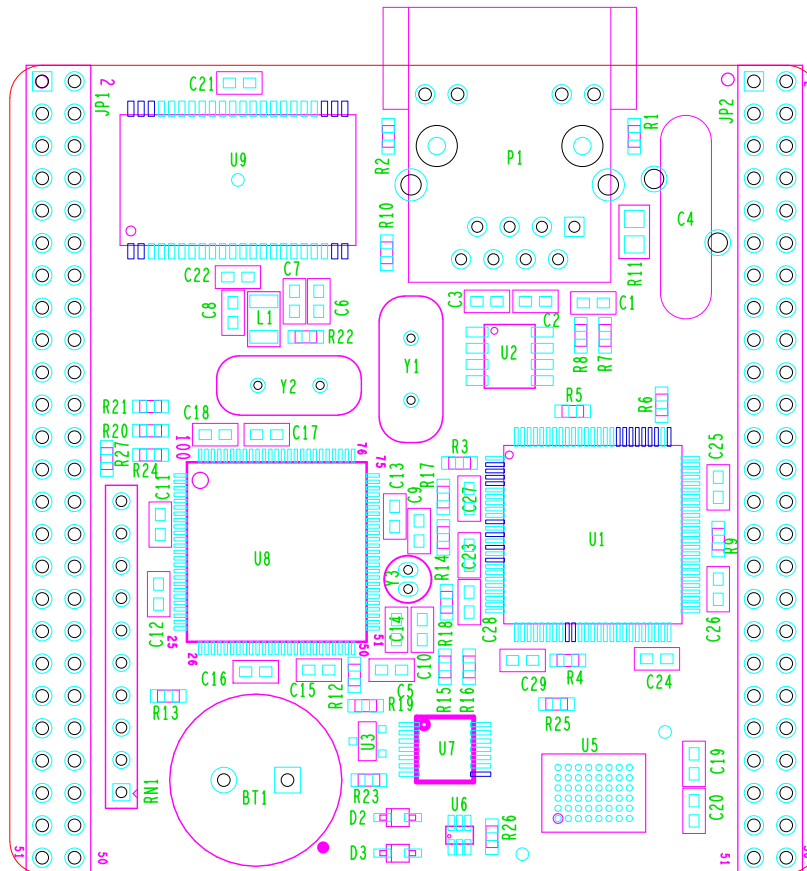

Figure 5. Top View

Mounting the Module onto the eZ80[®] Development Platform

The eZ80L92 Module can be mounted in several positions. Depending on volume and area restrictions, it can be mounted horizontally or vertically with or without components between the connectors on the eZ80[®] Development Platform. See Figure 6 for examples.

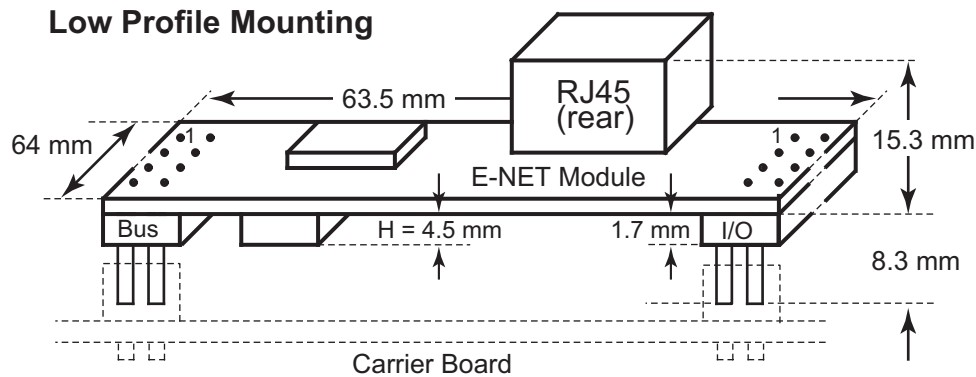

Figure 6. Mounting Examples

ESD/EMI Protection



Caution: The eZ80L92 Module is a component that is intended to be part of a system design for end-user devices. Therefore, the user must exercise caution to use ESD protection on the I/O pins.

The EMAC can be additionally protected by placing an ESD protection array on the eZ80L92 Module at position U9. Either use ESDA25B1 from ST Microelectronics or LCDA15C-6 from Semtech. A mounting hole on the board can be used for grounding the shield of the Ethernet RJ45 jack to prevent surge or ESD currents from flowing through the digital circuitry.

The RJ45 Ethernet Connector on the eZ80L92 Module contains a transformer and common mode chokes for EMI suppression.



Caution: CMOS I/Os are ESD-sensitive and must be handled with care. Handling of the module should be performed in ESD-safe environments (for example with a wrist-wrap attached). When developing applications, the user must provide for proper ESD protection on external, user-accessible I/Os (e.g. suppressor arrays for the I/Os).

The components are mounted on a multilayer PCB to provide a stable ground plane for on-board components. The module features several GND pins next to pins with higher switching frequency for short ground returns. If unused, the clock output can be separated

from the module header by removing a series resistor on the module. Removing the series resistor further reduces electromagnetic emissions.

Absolute Maximum Ratings

Stresses greater than those listed in Table 10 can cause permanent damage to the device. These ratings are stress ratings only. Operation of the device at any condition outside those indicated in the operational sections of these specifications is not implied. Exposure to absolute maximum rating conditions for extended periods may affect device reliability. For improved reliability, unused inputs should be tied to one of the supply voltages (V_{DD} or V_{SS}).

Table 10. Absolute Maximum Ratings

Parameter	Min	Max	Units
Standard operating temperature	0	+70	°C
Storage temperature	-45	+85	°C
Operating Humidity (RH @ 50°C)	25%	90%	
Operating Voltage ($\pm 5\%$)	-	3.3	V

Power Supply

The eZ80L92 Module requires a regulated external 3.3VDC/0.5A power supply. You may use a Low Dropout Regulator (LDO) to get 3.3V from 5V or use the following switcher circuit to generate 3.3V from unregulated 10-28V power supply.

Power connections follow these conventional descriptions:

Connection	Circuit	Device
Power	V_{CC}	V_{DD}
Ground	GND	V_{SS}

Figure 7 offers two typical power supply examples.

Switcher 10–28V → 3.3V

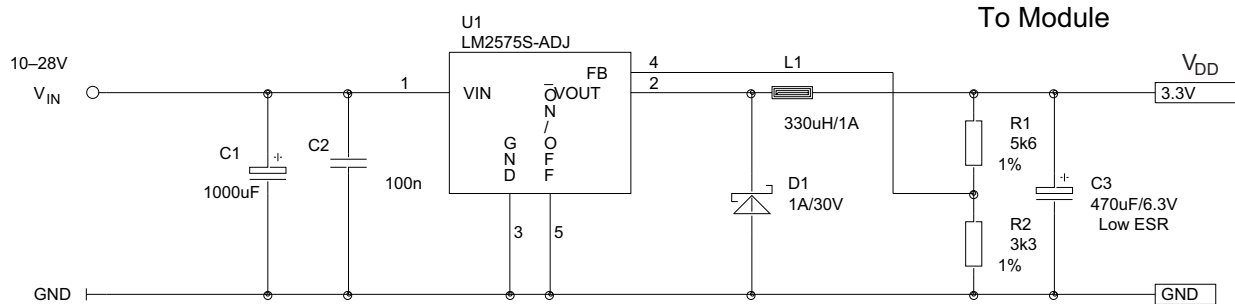

LDO 5V → 3.3V

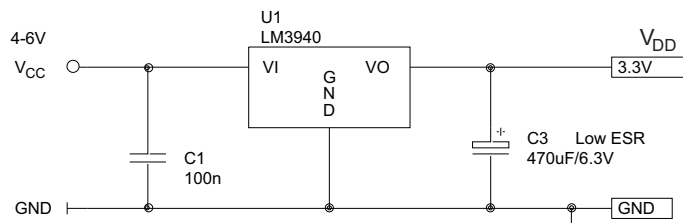

Figure 7. Power Supply Examples

Schematic Diagrams

Figures 8 through 11 diagram the layout of the eZ80L92 Module.

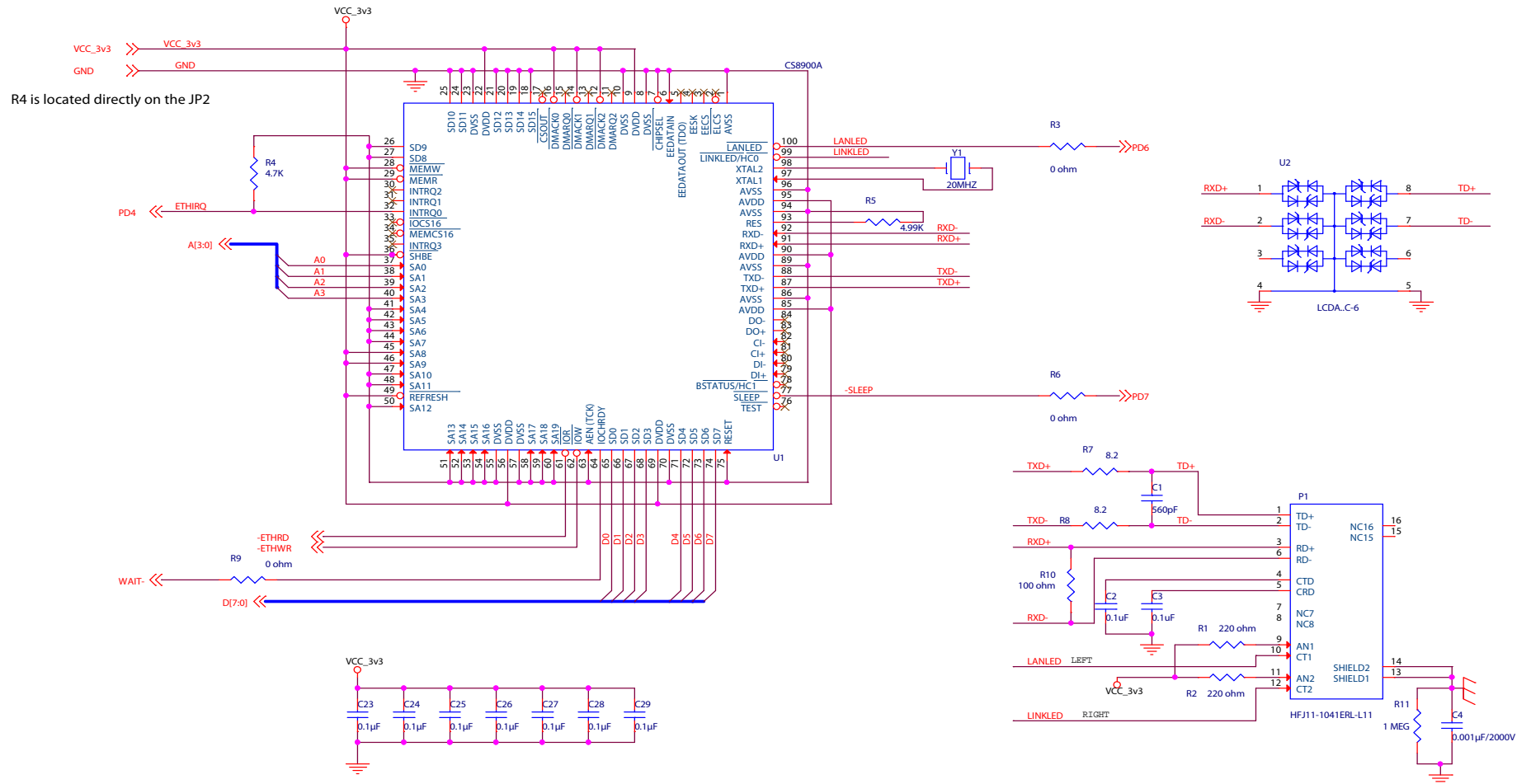

Figure 8. eZ80L92 Module Schematic Diagram, #1 of 4: EMAC and Ethernet Connections

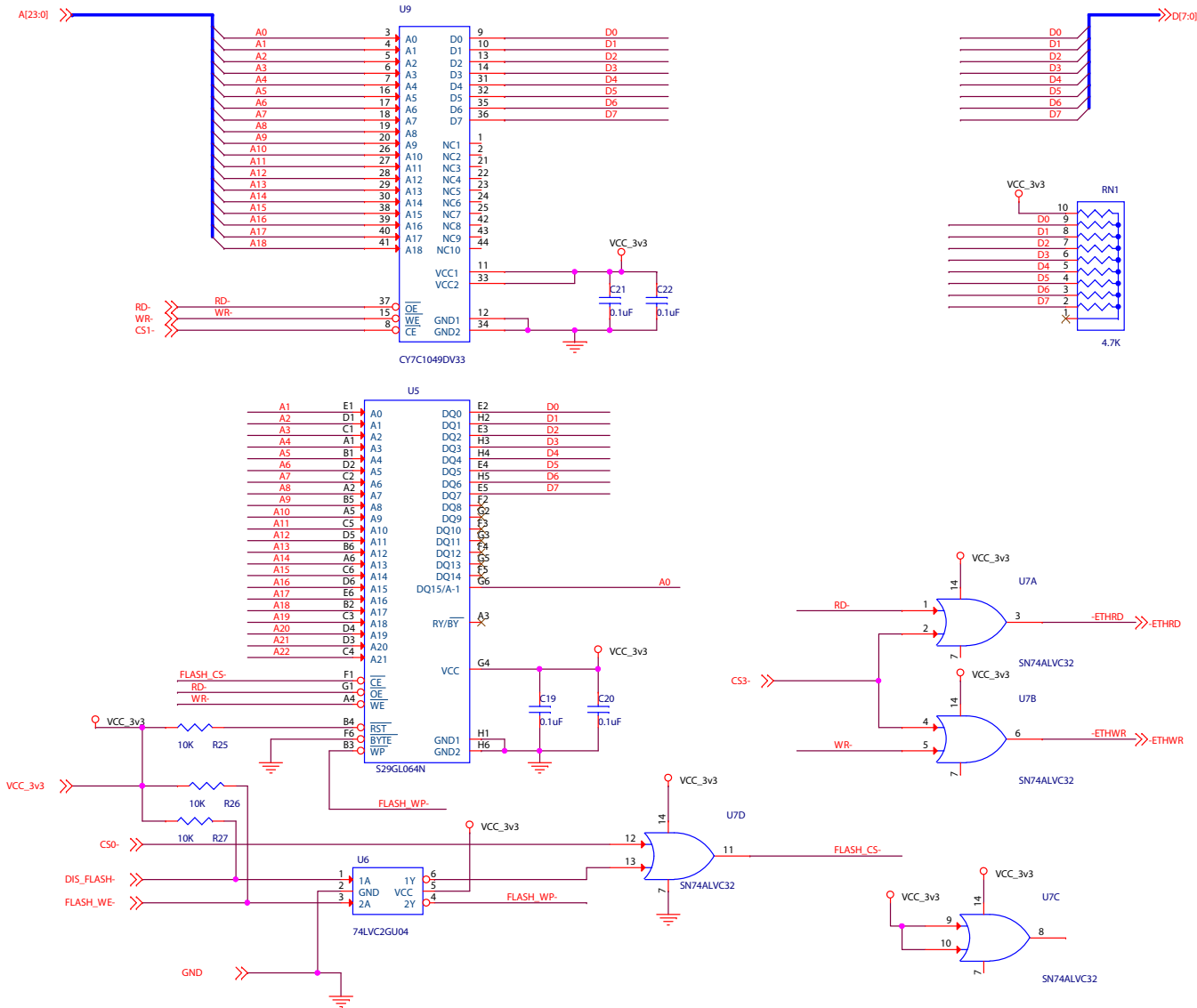

Figure 9. eZ80L92 Module Schematic Diagram, #2 of 4: Memory

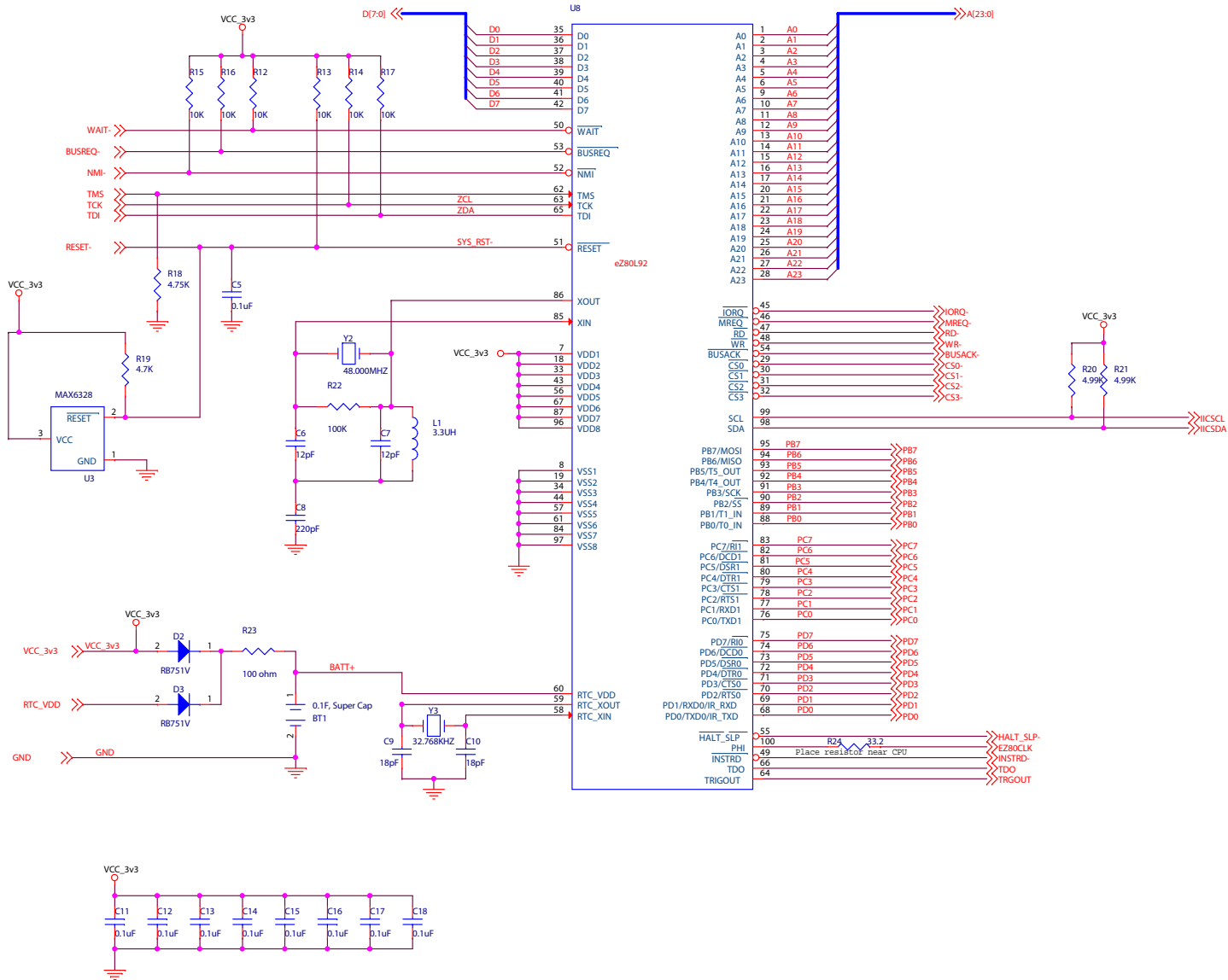

Figure 10. eZ80L92 Module Schematic Diagram, #3 of 4: eZ80L92 Device

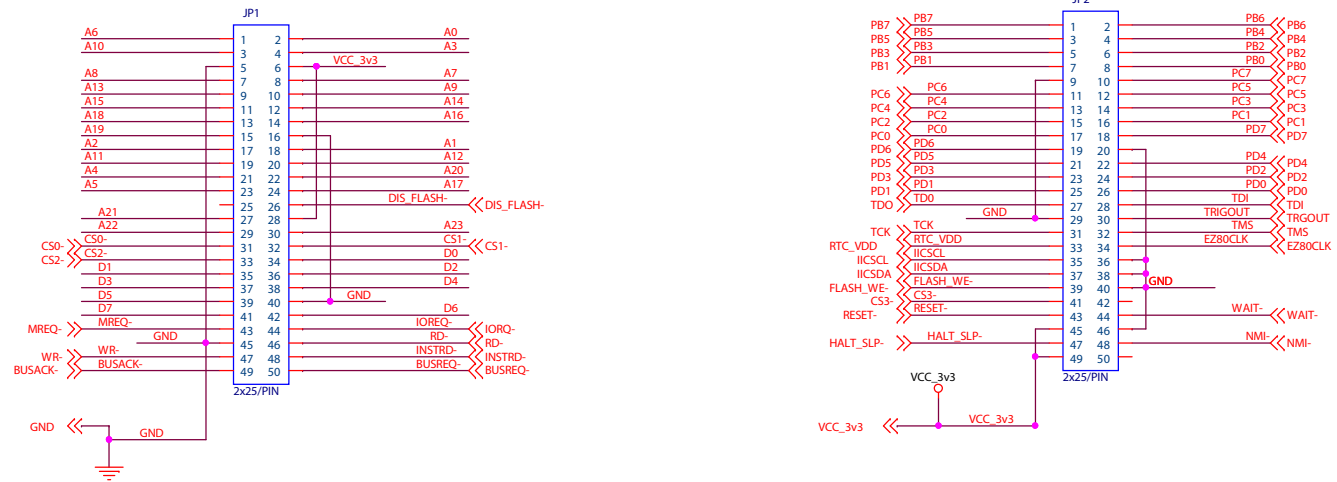
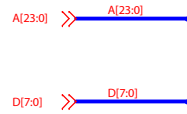

Figure 11. eZ80L92 Module Schematic Diagram, #4 of 4: Interfaces

Customer Support

To share comments, get your technical questions answered, or report issues you may be experiencing with our products, please visit Zilog's Technical Support page at <http://support.zilog.com>.

To learn more about this product, find additional documentation, or to discover other facets about Zilog product offerings, please visit the [Zilog Knowledge Base](#) or consider participating in the [Zilog Forum](#).

This publication is subject to replacement by a later edition. To determine whether a later edition exists, please visit the Zilog website at <http://www.zilog.com>.

Mouser Electronics

Authorized Distributor

Click to View Pricing, Inventory, Delivery & Lifecycle Information:

ZiLOG:

[EZ80L925148MODG](#)