

FRONT VIEW W/O CPA
(P/N 54550403N SHOWN)
SEE PART NUMBER CHART

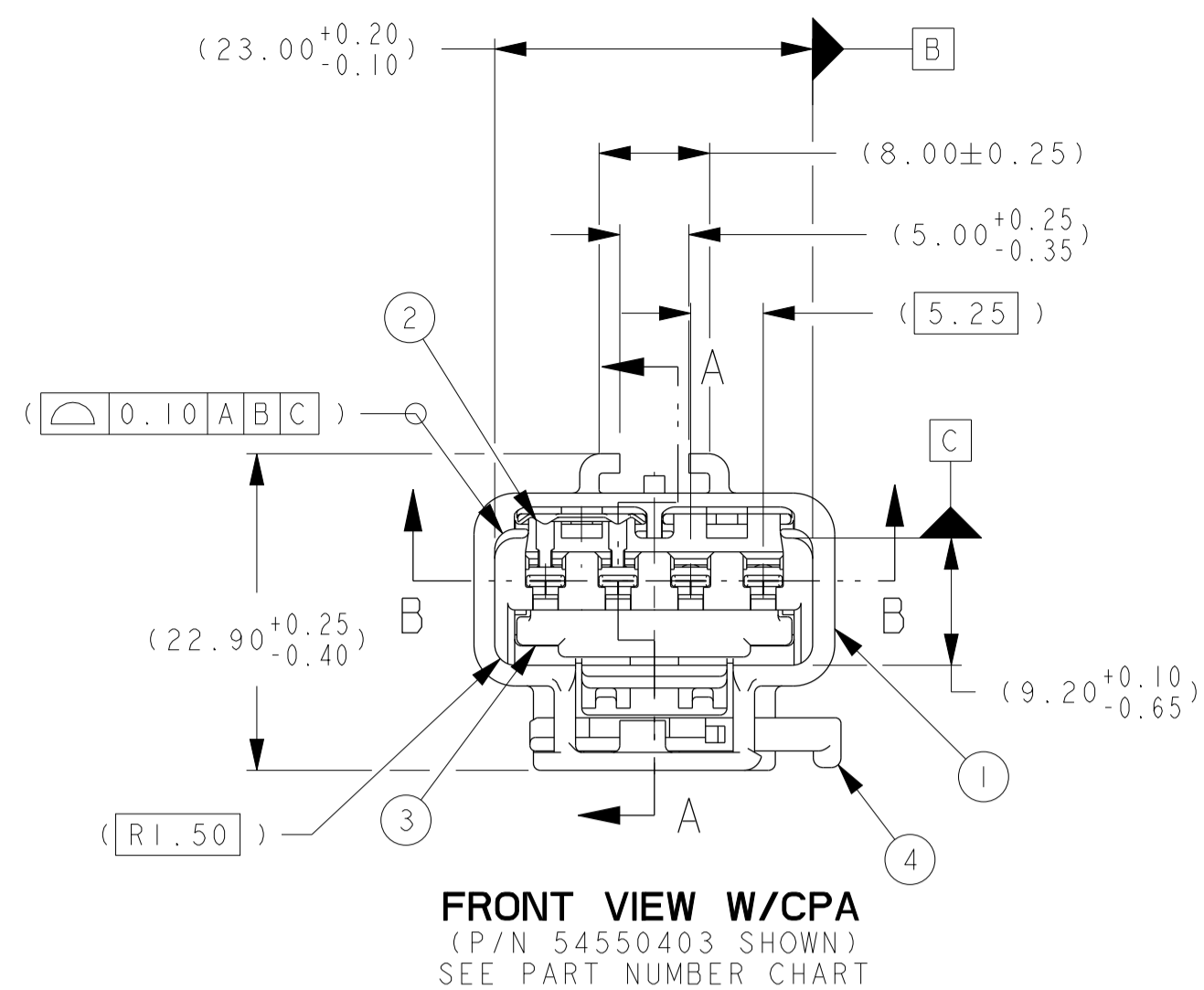

FRONT VIEW W/CPA
(P/N 54550403 SHOWN)
SEE PART NUMBER CHART

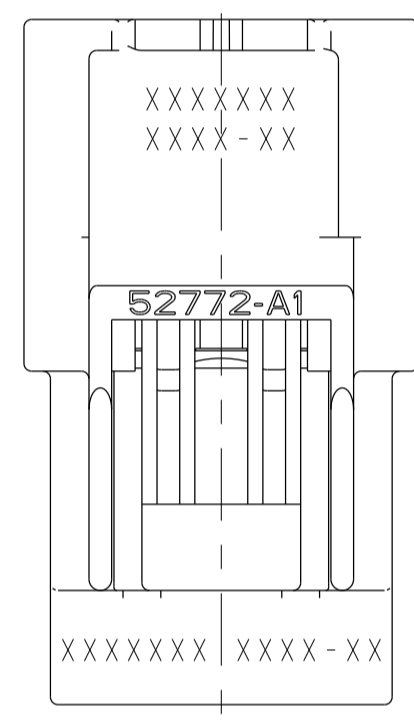

OPTIONAL LOCATION FOR
PART IDENTIFICATION

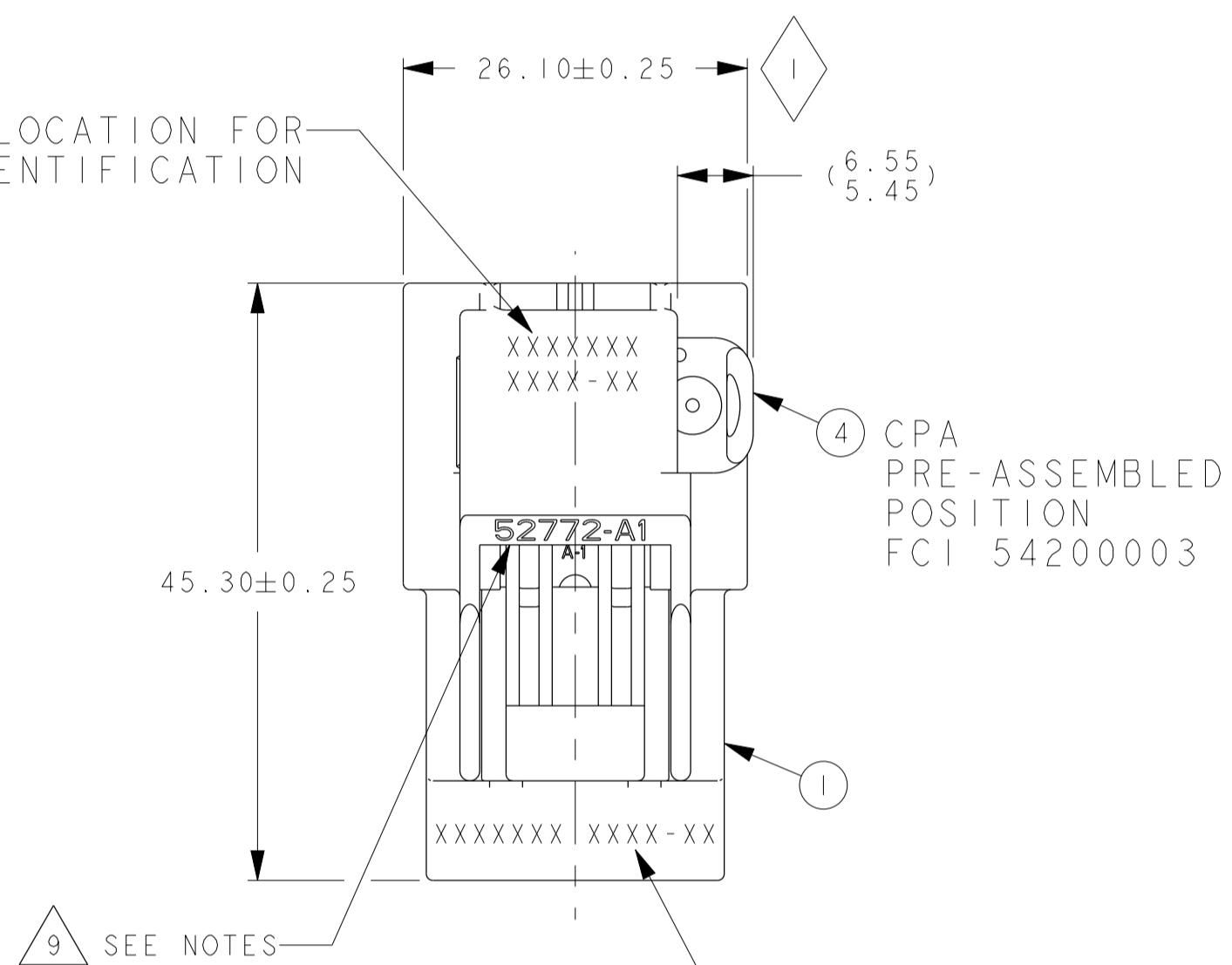

CPA
PRE-ASSEMBLED
POSITION
FCI 54200003

9 SEE NOTES

LAST 5 DIGITS OF 8 DIGIT P/N &
PART CHANGE LEVEL (PCL) OR

LAST 6 DIGITS OF 9 DIGIT P/N
OR 10 DIGIT P/N & PART CHANGE
LEVEL (PCL)

MFG. DAILY DATE CODE & ASSY
MACHINE NO. LETTERING MUST
BE LEGIBLE

OPTIONAL

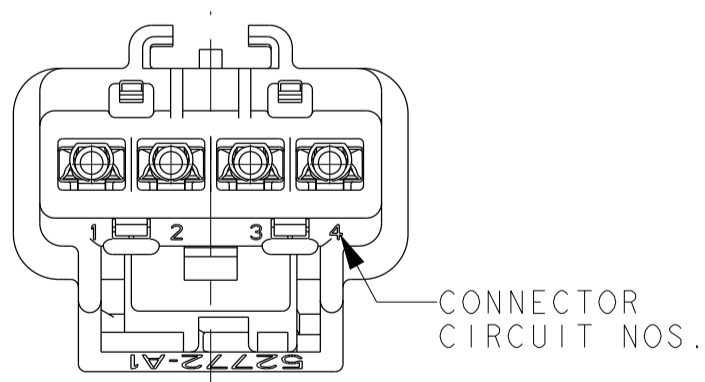

BACK VIEW
W/O CPA

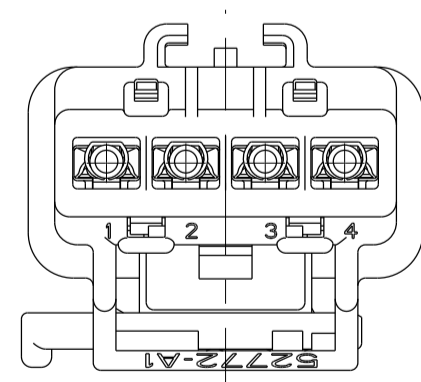

BACK VIEW
W/CPA

CONNECTOR
CIRCUIT NOS.

(TERMINAL-MALE
FCI C15005)

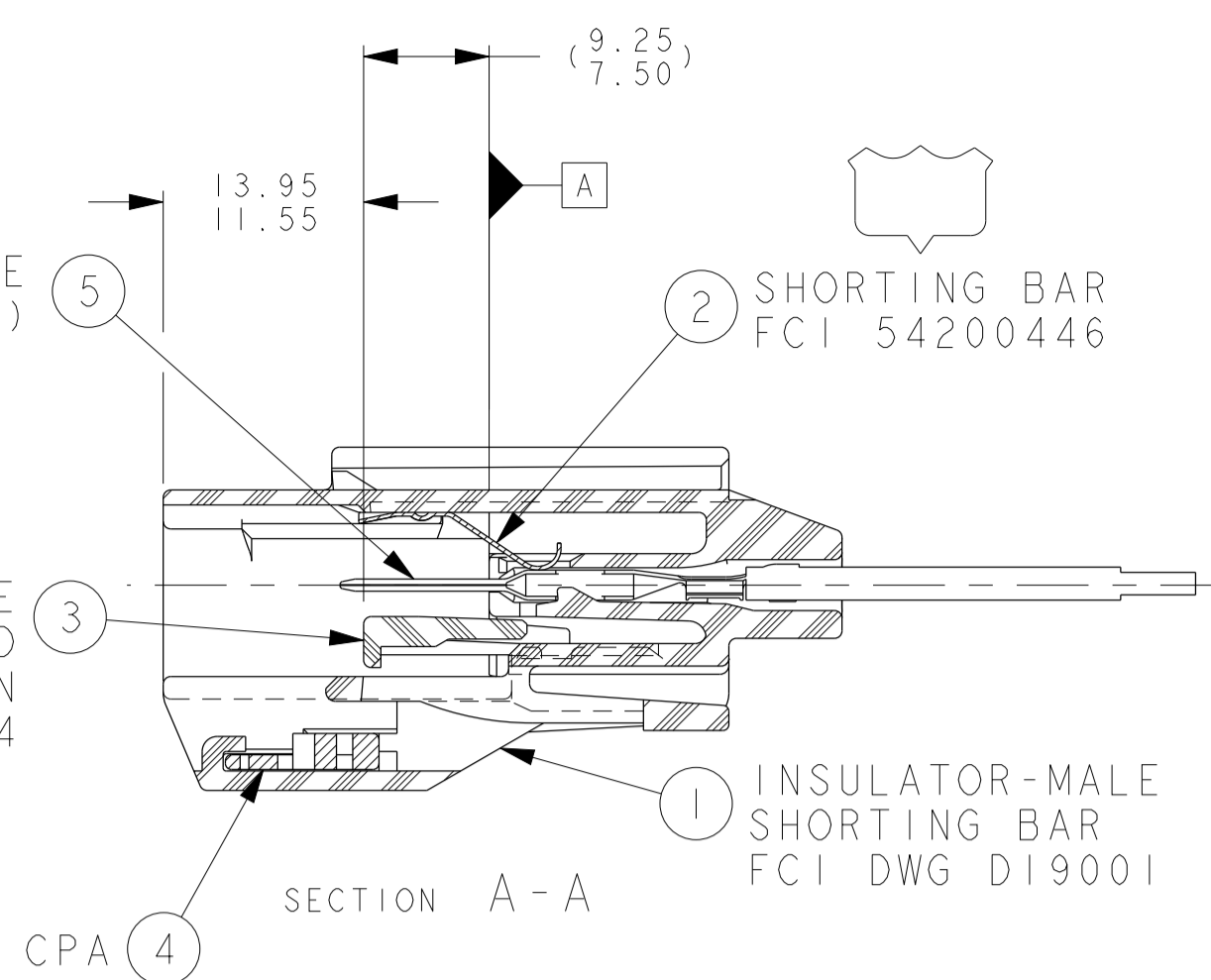

SECTION A-A

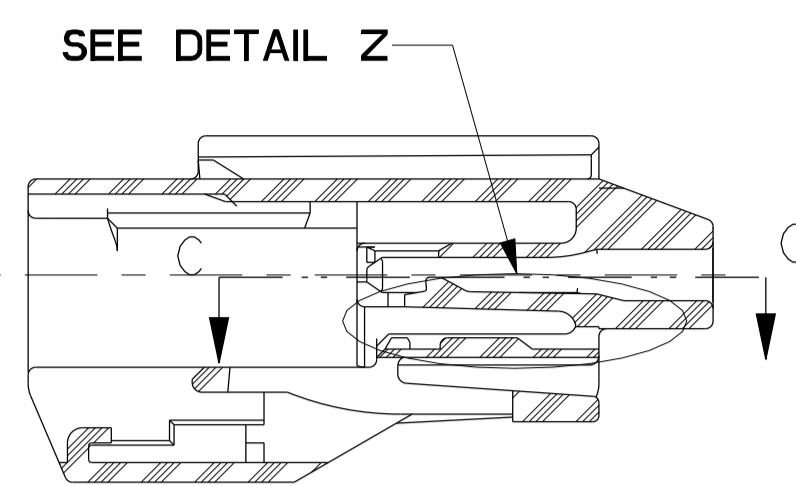

SUPPLEMENTAL SECTION A-A

INSULATOR VIEWS
FOR REFERENCE

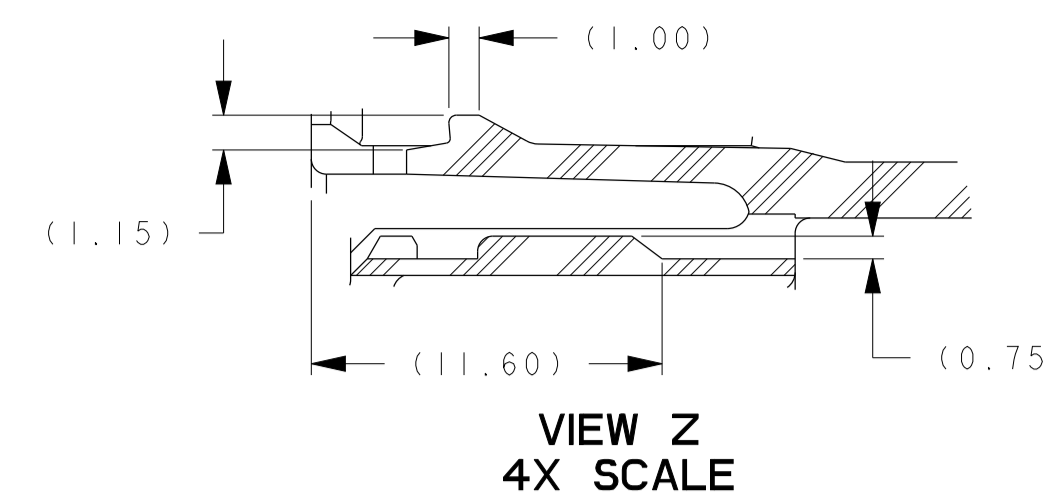

VIEW Z
4X SCALE

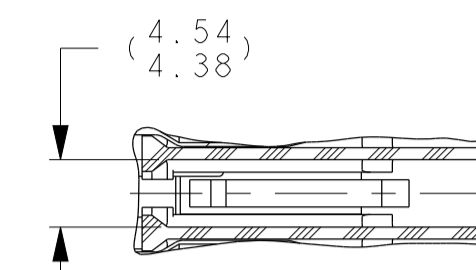

PARTIAL
SECTION C-C

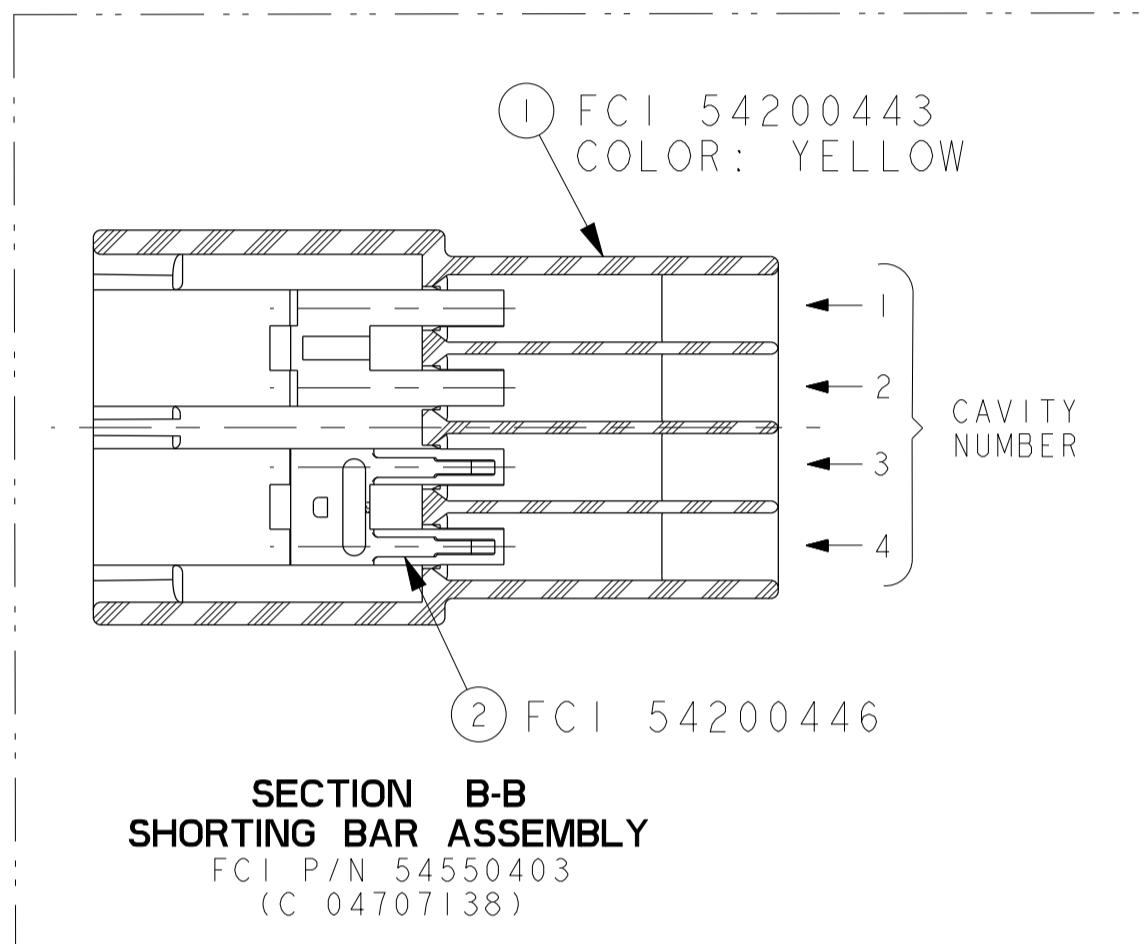

SECTION B-B
SHORTING BAR ASSEMBLY
FCI P/N 54550403
(C 04707138)

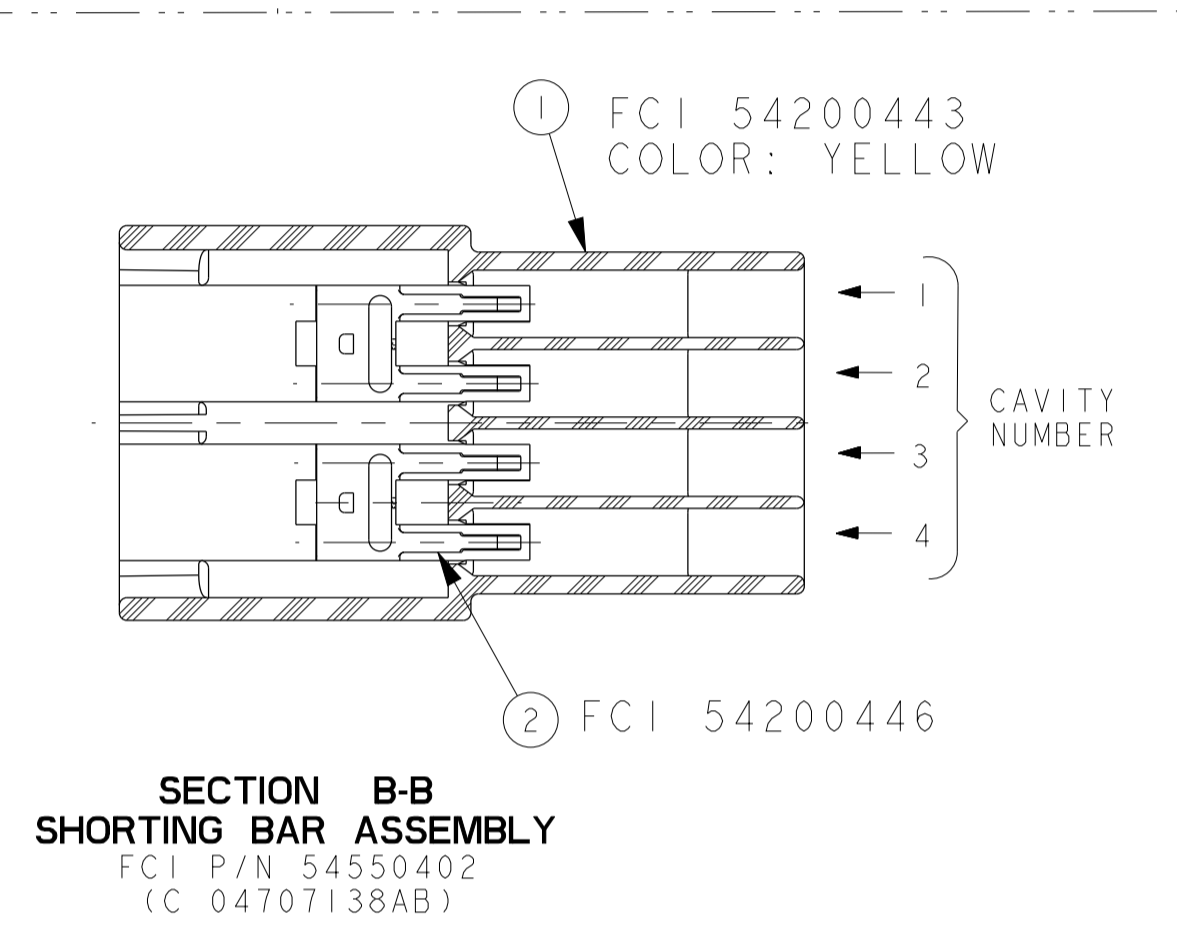

SECTION B-B
SHORTING BAR ASSEMBLY
FCI P/N 54550402
(C 04707138AB)

NOTES:

- 1 QUALITY ASSURANCE REQUIREMENTS PER CHRYSLER PS-7300:1 SPC DATA REQUIRED
 - 2 ENGINEERING APPROVAL OF SUPPLIER SAMPLES IS REQUIRED PRIOR TO AUTHORIZATION OF PART PRODUCTION.
 - 3 CHANGES IN DESIGN COMPOSITION OR PROCESSING FROM THE PART PREVIOUSLY APPROVED FOR PART PRODUCTION REQUIRES PRIOR ENGINEERING APPROVAL
 - 4 WIRE FABRICATORS MUST PURCHASE FROM SOURCES SHOWN
 - 5 RECOMMENDED TO BE USED WITH THINWALL INSULATION 22 GA. THRU 14 GA. PER MS-8288, MS-9502 OR MS-7889 (EXCEPT AS NOTED) PROVIDING THAT TERMINAL GRIP FOR THAT CORE/INSULATION COMBINATION IS SHOWN ON THE MALE TERMINAL DRAWING
MAX. CORE CRIMP WIDTH= 2.85
MAX. CORE CRIMP HEIGHT= 2.25
MAX. INSULATION CRIMP WIDTH= 3.60
MAX. INSULATION CRIMP HEIGHT= 3.23
 - 6 USE WITH DOUBLE X-MAS TREE CLIP P/N 04707091 WHEN REQUIRED
USE WITH SINGLE X-MAS TREE CLIP P/N 04625797 WHEN REQUIRED
USE WITH 2.80MM APEX MALE TERM PER C15005-CUST SYM ABOUT CENTERLINE 180° ORIENTATION PERMISSIBLE
 - 7 PART MATES WITH FCI P/N 54550400 (CHRYSLER P/N 04707139)
 - 8 TEST METHOD PER CHRYSLER PERFORMANCE SPEC# PF-9600. CONNECTOR ENGAGE & DISENGAGE WITH FEMALE LATCH DEPRESSED FORCE NOT TO EXCEED 90 N FOR THIS SYSTEM
 - 9 SUPPLIER, MOLD & CAVITY I.D. SIGNIFIES TOOL OWNERSHIP, FOR REFERENCE
 - 10 ANNUAL QUALITY REQUIREMENTS:
IT IS PERMISSIBLE TO PERFORM CONTINUOUS CONFORMANCE PER FCI SPECIFICATION #AQA-001 INSTEAD OF ANNUAL LAYOUT & ANNUAL PV REQUIREMENTS OF QS-9000 SECTION 2 & PF-9600
- ALL NON-REFERENCE DIMENSIONS ARE REQUIRED
- CURRENT PRODUCTION TOOLING
 - POINT OF LAST RUN
- SERVICE TOOLING GUIDE INFORMATION PER APEX TRAINING MANUAL

11 MUST CONFORM TO THE FOLLOWING CHRYSLER STANDARDS:

PF-9600 PERFORMANCE CHRYSLER EXCEPT AS NOTED ABOVE
PS-7300 QUALITY ASSURANCE CHRYSLER
PF-SAFETY
PS-4480-CEK-4 CHRYSLER PART I.D., (G-009-2 YNA)
PS-9065 REGRIND, CHRYSLER (G-009-7 YNA)
PS-9227 DATA EXCHANGE, CHRYSLER (G-009-7 YNA)
PS-10052 INFORMATION SECURITY CHRYSLER

12 THIS DRAWING (H59004) REPLACES CHRYSLER DRAWING NUMBER 04707464 LEVEL "G" CHRYSLER DRAWING IS FOR REFERENCE ONLY

13 FCI P/N'S WITH SUFFIX "N" DESIGNATES ASSEMBLIES WITHOUT CPA

LEGENDS:
CHRYSLER: C
TRW: TRW

FCI	52772 OR 52772 H
VENDOR	VENDOR CODE

F540210	L	54550402N	K	N/A	N/A	1 & 2 + 3 & 4
		54550403N	K	N/A	N/A	3 & 4
F640210	L	54550402	K	04707138AB	TRW 2003103D	1 & 2 + 3 & 4
		54550403	K	04707138	N/A	3 & 4
		W/O SHT. CLIP	PCL	W/ SHT. CLIP		
		FCI PART NO.	PCL	(CHRYSLER) PART NO.	CUSTOMER PART NO.	SHORTING BAR LOC.

12-00125	ALL	REVISED AND REDRAWN IN PDS SEE REV K1 FOR PREVIOUS CHANGES ADDED P/N'S F540210 AND F640210 WITHOUT SHORTING BARS AND MATING P/N CHART REVISED P/N'S 54200401 & 54200401N COLOR ORANGE REMOVED NOT AVAILABLE
ECN-NO.	ZONE	CHANGE DESCRIPTION
PROJECT SPEC.	PACKAGING SPEC.	APPLICATION SPEC.
THIS DRAWING AND ALL OTHER INFORMATION CONTAINED THEREIN IS PROPRIETARY AND THE PROPERTY OF FCI. THIS DRAWING MAY NOT BE COPIED, REPRODUCED OR DISCLOSED TO ANY THIRD PARTY WITHOUT THE EXPRESSED WRITTEN PERMISSION OF FCI. FCI April 10, 1999		
TOLERANCES	SEE DWG	MATERIAL: PA66GF SURFACE FINISH
CONFORM TO:	H59013	COLOR: YELLOW
DO NOT MEASURE DRAWING	TOOL NO. A-035	ECO Loc. C46 AN
DATE	NAME	TITLE
2008-09-31	RAJAJUMAR	CHART-ASSEMBLY
2010-09-09	Santhosh BIAN	4-WAY MALE
2010-09-09	Frank HOLZBL	PROJECT SHORTING BAR (UNSEALED)
2010-09-09	JIM CAMPBELL	28MM APEX CONNECTOR SYSTEM
FILE NAME	H59004	DOCUMENT UNDER PDS CONTROL. NO MODIFICATION ALLOWED OUTSIDE

H59004
SERIAL RELEASED
 See Table

Mouser Electronics

Authorized Distributor

Click to View Pricing, Inventory, Delivery & Lifecycle Information:

[Aptiv:](#)

[54550402](#) [54550403](#) [54550403-B](#) [54550402-B](#)