

REVISIONS					
P	LTR	DESCRIPTION	DATE	DWN	APVD
	NC	NEW RELEASE PER E.O. P17008	19DEC2000	DM	RDR
	A	REVISED PER PCN E-18-012207	31JUL2018	JA	DM

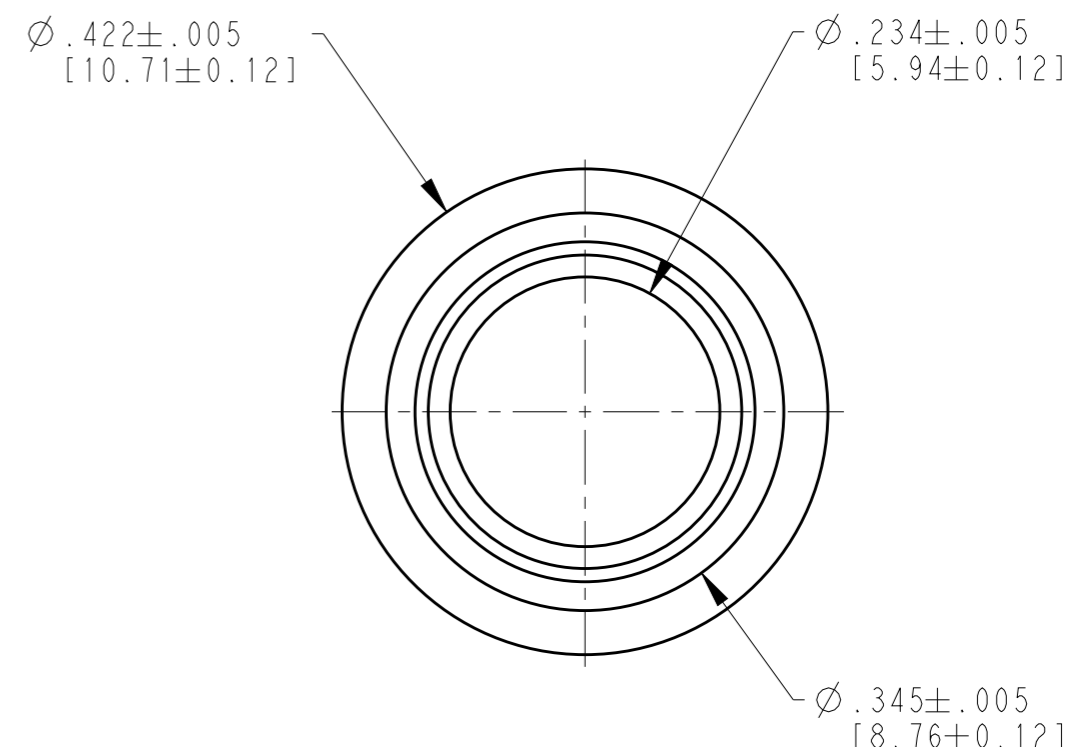
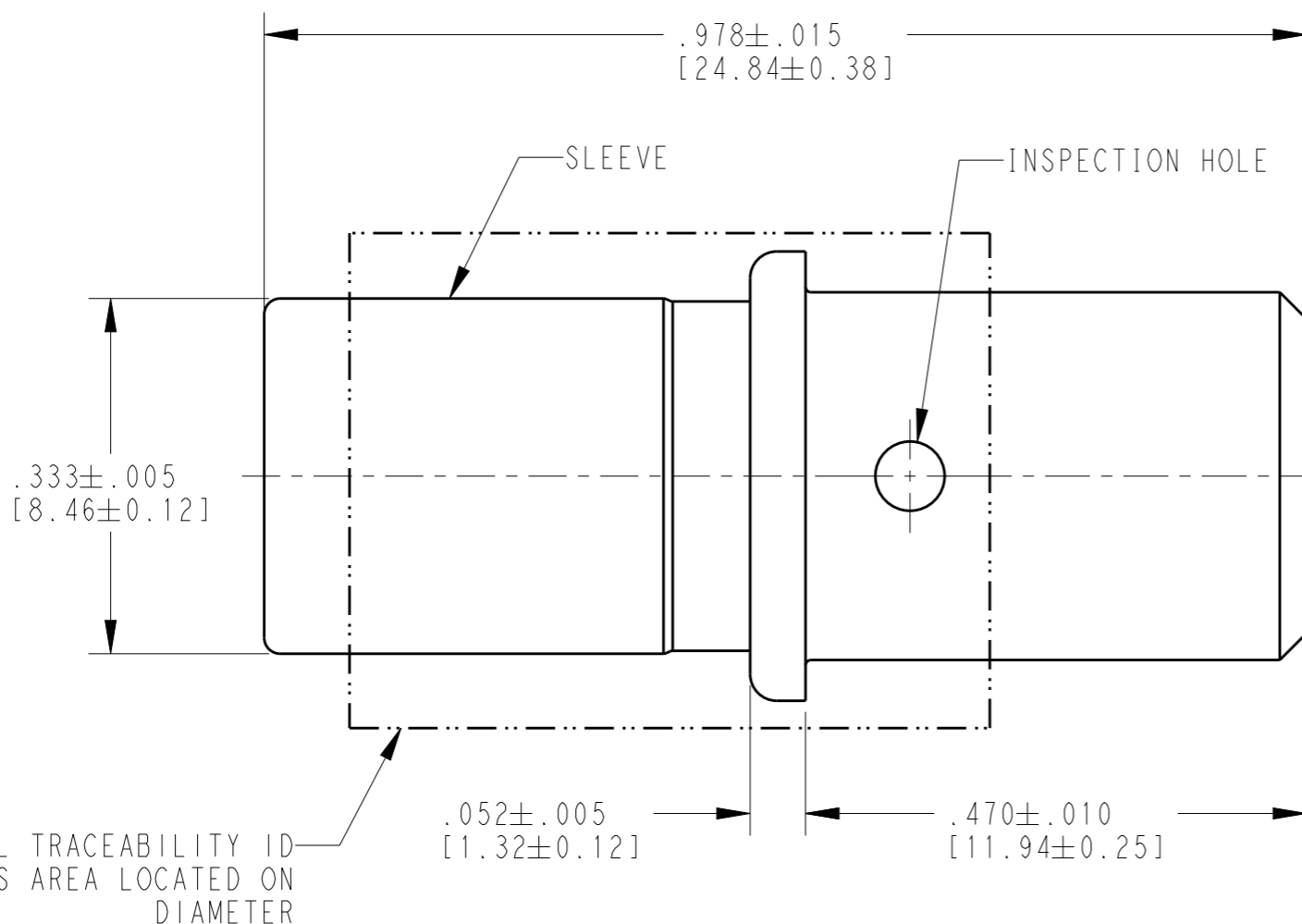

2. WIRE RANGE: 6 AWG [13.0 mm^2].

1. THIS CONTACT MAY BE CRIMPED WITH HDP-400 POWER CRIMPER OR HDT-04-08 HAND TOOL.

NOTES: UNLESS OTHERWISE SPECIFIED

TE INTERNAL PN	DEUTSCH PN	PLATING
0462-203-04141	0462-203-04141	NICKEL

THIS DRAWING IS A CONTROLLED DOCUMENT.		DWN D. MEYER 29NOV2000	 TE Connectivity													
DIMENSIONS: INCHES [mm]		CHK B. BYFORD 18DEC2000														
TOLERANCES UNLESS OTHERWISE SPECIFIED:		APVD D. MEYER 09JAN2001	NAME SOCKET, SOLID SIZE 4, 6 AWG													
<table border="0"> <tr><td>0 PLC</td><td>±</td></tr> <tr><td>1 PLC</td><td>±</td></tr> <tr><td>2 PLC</td><td>±</td></tr> <tr><td>3 PLC</td><td>±</td></tr> <tr><td>4 PLC</td><td>±</td></tr> <tr><td>ANGLES</td><td>±</td></tr> </table>		0 PLC	±	1 PLC	±	2 PLC	±	3 PLC	±	4 PLC	±	ANGLES	±	PRODUCT SPEC 0425-015-0000	SIZE A3	
0 PLC	±															
1 PLC	±															
2 PLC	±															
3 PLC	±															
4 PLC	±															
ANGLES	±															
MATERIAL		APPLICATION SPEC 0425-205-0000	CAGE CODE 4AFU8	DRAWING NO 0462-203-04XX												
FINISH		WEIGHT 7.48g	RESTRICTED TO -													
CUSTOMER DRAWING			SCALE 6:1	SHEET 1 OF 1												
			REV A													