

# AS3933

## 3D Low Frequency Wakeup Receiver

### 1 General Description

The AS3933 is a 3-channel low power ASK receiver that is able to generate a wakeup upon detection of a data signal which uses a LF carrier frequency between 15-150 kHz. The integrated correlator can be used for detection of a programmable 16-bit or 32-bit Manchester wakeup pattern. The device can operate using one, two, or three active channels.

The AS3933 provides a digital RSSI value for each active channel, it supports a programmable data rate and Manchester decoding with clock recovery. The AS3933 offers an internal Clock Generator, which is either derived from a crystal oscillator or the internal RC oscillator. The user can decide to use the external clock generator instead.

The programmable features of AS3933 enable to optimize its settings for achieving a longer distance while retaining a reliable wakeup generation. The sensitivity level of AS3933 can be adjusted in presence of a strong field or in noisy environments.

Antenna tuning is greatly simplified, as the automatic tuning feature ensures perfect matching to the desired carrier frequency.

The device is available in 16 pin TSSOP and QFN 4x4 16LD packages.

### 2 Key Features

- 3-channel ASK wakeup receiver
- Carrier frequency range 15 - 150 kHz
- One, two, or three channel operation
- Reliable 1-, 2- or 3-D wakeup pattern detection
- Programmable wakeup pattern (16-bit or 32-bit) Manchester
- Doubling of wakeup pattern supported (both for 16 and 32 bits)
- Wakeup without pattern detection supported

- Wakeup sensitivity 80  $\mu$ V<sub>RMS</sub> (typ)
- Adjustable sensitivity level
- Highly resistant to false wakeups
- Easy antenna tuning for perfect matching on the wanted carrier frequency
- Self calibration of the internal RC-oscillator
- False wakeup counter
- Periodical forced wakeup supported (1s – 2h)
- Low power listening modes
- Current consumption in 3-channel listening mode 1.7  $\mu$ A (typ)
- Data rate adjustable from 0.5- 4 kbps (Manchester)
- Manchester decoding with clock recovery
- Digital RSSI values available for each channel
- Dynamic range 64dB
- 5-bit RSSI step (2dB per step)
- Clock Generator based on 32kHz XTAL, RC-OSC, or External Clock
- Operating temperature range -40 to +85°C
- Operating supply voltage 2.4 - 3.6V (TA = 25°C)
- Bidirectional serial peripheral interface (SPI)
- Package option: 16 pin TSSOP, QFN 4x4 16LD

### 3 Applications

The AS3933 is ideal for Active RFID tags, Real-time location systems, Operator identification, Access control, and Wireless sensors.

Figure 1. AS3933 Typical Application Diagram with Crystal Oscillator

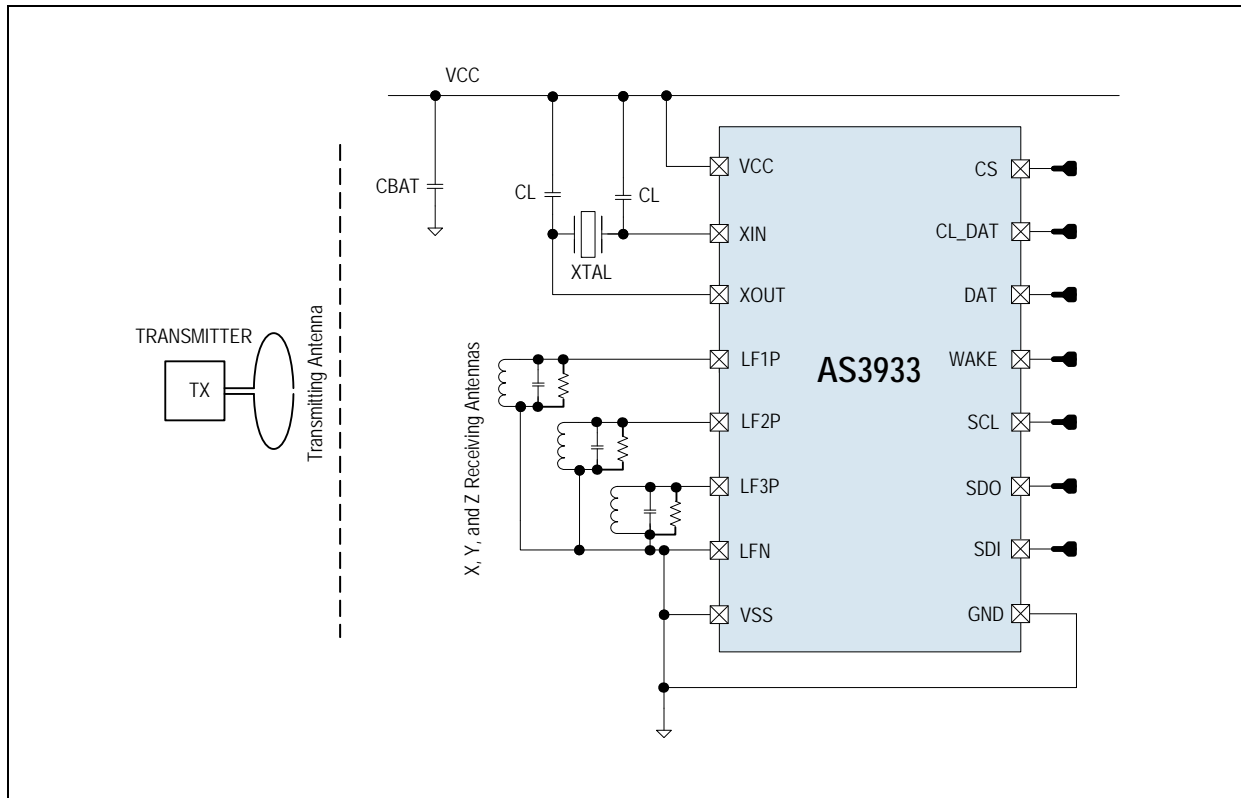

Figure 2. AS3933 Typical Application Diagram with RC Oscillator

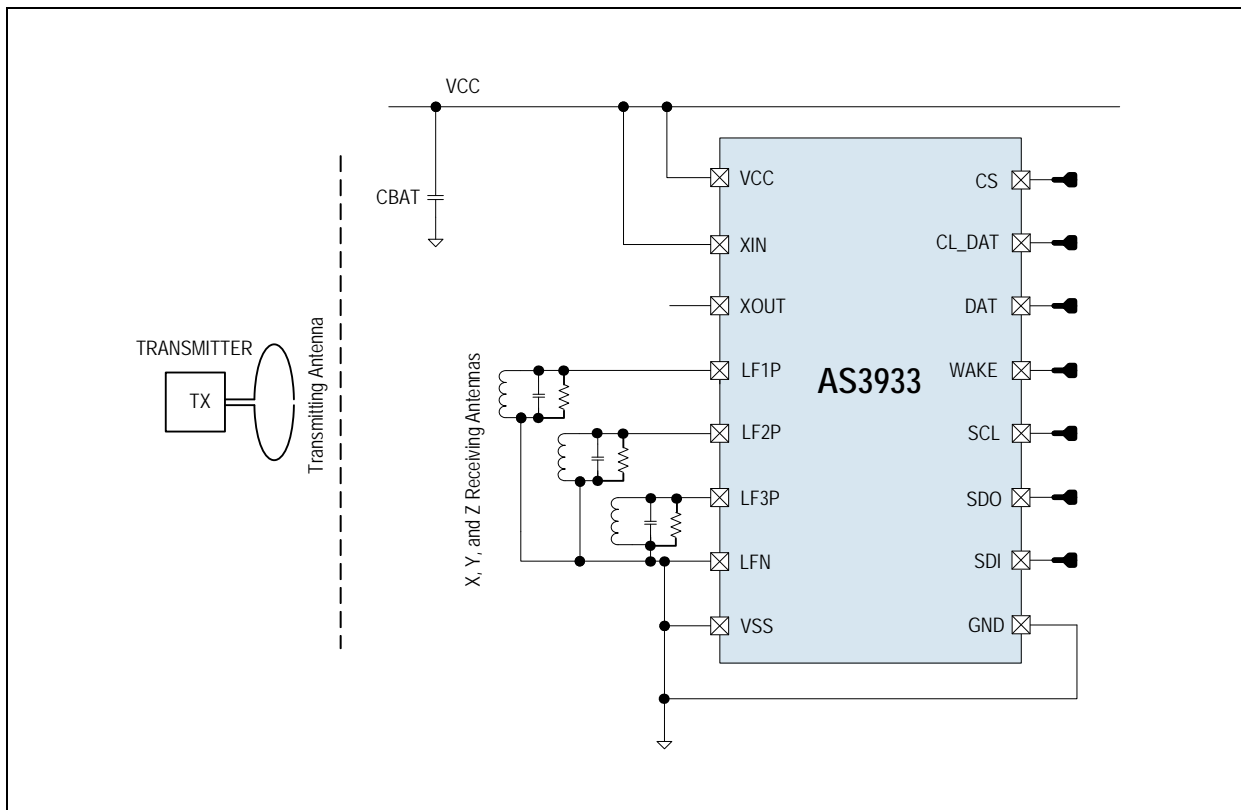
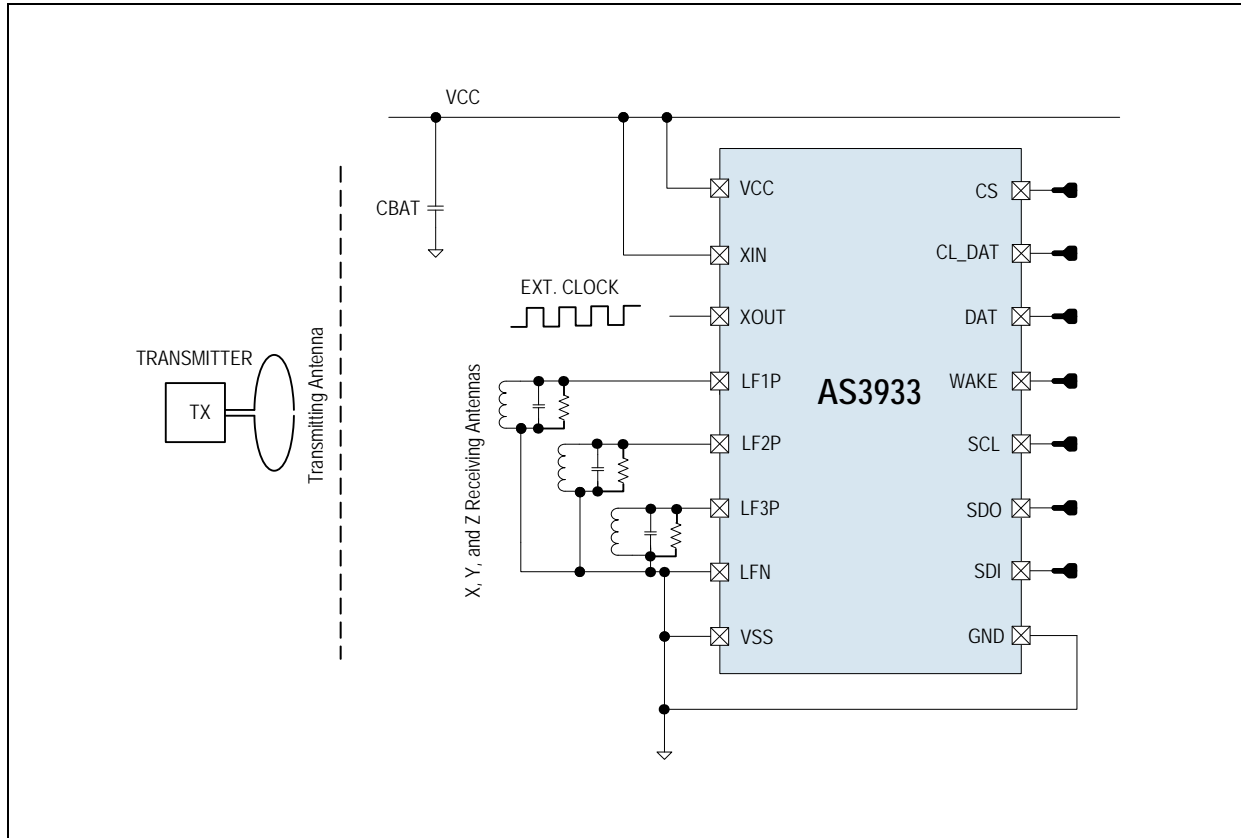

Figure 3. AS3933 Typical Application Diagram with Clock from External Source



## Contents

1	General Description .....	1
2	Key Features.....	1
3	Applications.....	1
4	Pin Assignments .....	5
4.1	TSSOP-16 Package .....	5
4.1.1	Pin Descriptions .....	5
4.2	QFN-16 Package.....	6
4.2.1	Pin Descriptions .....	6
5	Absolute Maximum Ratings .....	7
6	Electrical Characteristics.....	8
7	Typical Operating Characteristics .....	11
8	Detailed Description.....	12
8.1	Operating Modes .....	13
8.1.1	Listening Mode .....	14
8.1.2	Artificial Wakeup.....	15
8.1.3	Preamble Detection / Pattern Correlation .....	15
8.1.4	Data Receiving .....	15
8.2	System and Block Specification .....	16
8.2.1	Register Table .....	16
8.2.2	Register Table Description and Default Values .....	16
8.2.3	Serial Peripheral Interface (SPI) .....	18
8.2.4	SDI Timing.....	22
8.3	Channel Amplifier, Frequency Detector and RSSI .....	22
8.3.1	Frequency Detector / RSSI / Channel Selector .....	23
8.3.2	Antenna Damper.....	24
8.4	Demodulator / Data Slicer .....	25
8.5	Correlator.....	27
8.5.1	Pattern: Bit and Symbol Definition in Manchester Code.....	27
8.6	Wakeup Protocol .....	29
8.6.1	Wakeup Protocol: Frequency Detection Only.....	30
8.6.2	Wakeup Protocol: Pattern Detection Enabled .....	30
8.6.3	Manchester Decoder and Clock Recovery .....	32
8.7	False Wakeup Register .....	32
8.8	Clock Generator .....	34
8.8.1	Crystal Oscillator.....	34
8.8.2	RC-Oscillator .....	35
8.8.3	External Clock Source .....	36
8.9	Antenna Tuning .....	36
8.10	Channel Selection in Scanning Mode and ON/OFF Mode.....	37
9	Package Drawings and Markings .....	38
10	Ordering Information .....	41

## 4 Pin Assignments

### 4.1 TSSOP-16 Package

Figure 4. TSSOP Pin Assignments (Top View)

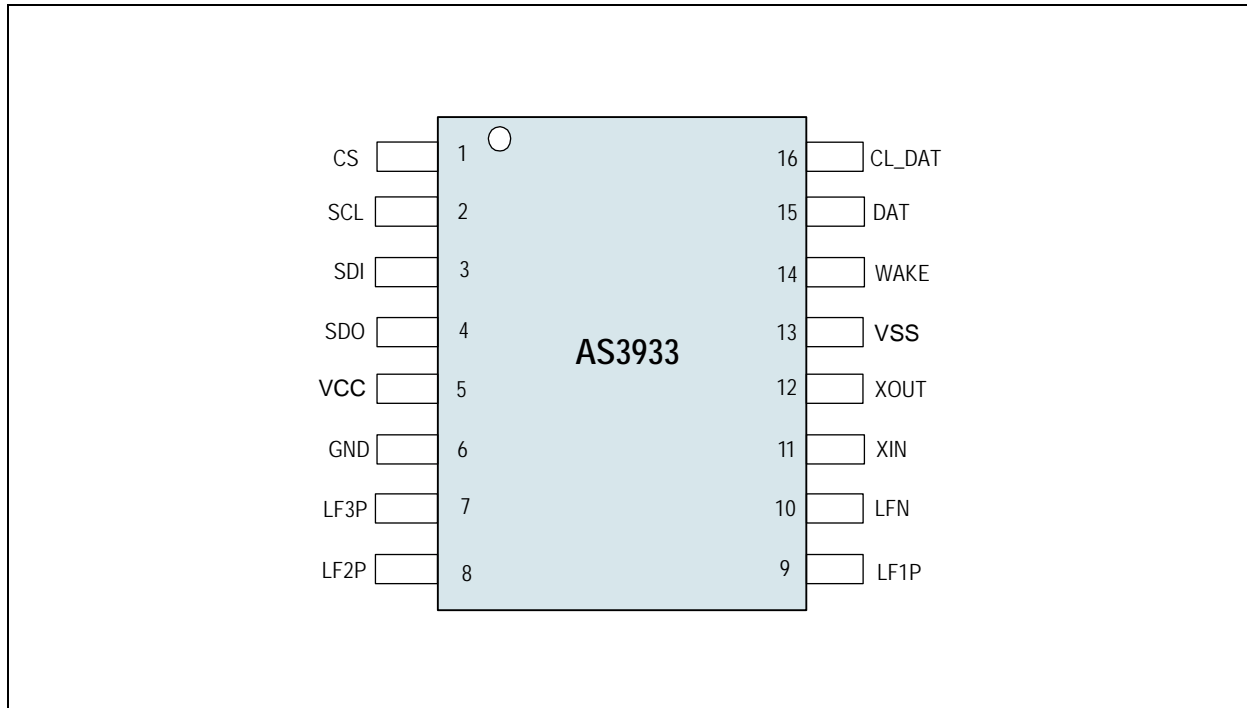

#### 4.1.1 Pin Descriptions

Table 1. TSSOP-16 Pin Descriptions

Pin Name	Pin Number	Pin Type	Description
CS	1	Digital input	Chip select
SCL	2		SDI interface clock
SDI	3		SDI data input
SDO	4	Digital output / tristate	SDI data output (tristate when CS is low)
Vcc	5	Supply pad	Positive supply voltage
GND	6		Negative supply voltage
LF3P	7	Analog I/O	Input antenna channel three
LF2P	8		Input antenna channel two
LF1P	9		Input antenna channel one
LFN	10		Common ground for antenna one, two and three
XIN	11		Crystal oscillator input
XOUT	12		Crystal oscillator output
Vss	13	Supply pad	Substrate
WAKE	14	Digital output	Wakeup output IRQ
DAT	15		Data output
CL_DAT	16		Manchester recovered clock

## 4.2 QFN-16 Package

Figure 5. QFN Pin Assignments (Top View)

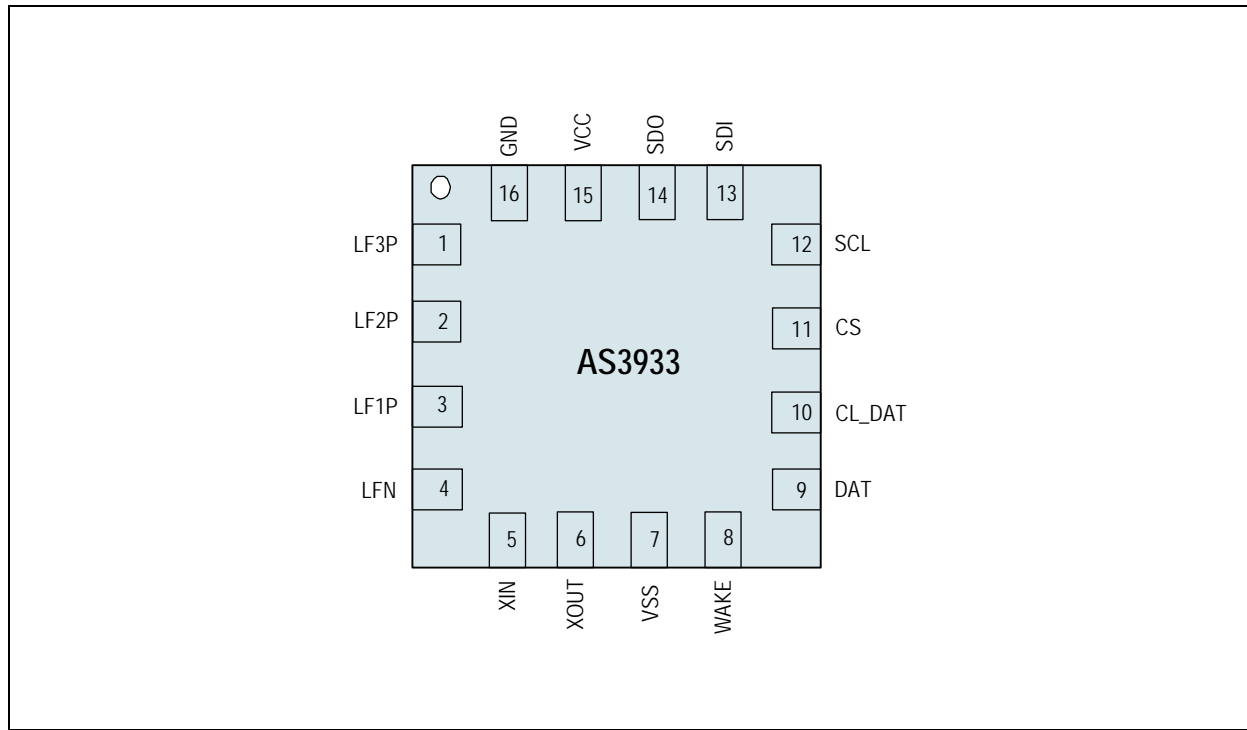

### 4.2.1 Pin Descriptions

Table 2. QFN-16 Pin Descriptions

Pin Name	Pin Number	Pin Type	Description
LF3P	1	Analog I/O	Input antenna channel three
LF2P	2		Input antenna channel two
LF1P	3		Input antenna channel one
LFN	4		Common ground for antenna one, two and three
XIN	5	Supply pad	Crystal oscillator input
XOUT	6		Crystal oscillator output
Vss	7	Digital output	Substrate
WAKE	8		Wakeup output IRQ
DAT	9		Data output
CL_DAT	10		Manchester recovered clock
CS	11	Digital input	Chip select
SCL	12		SDI interface clock
SDI	13		SDI data input
SDO	14	Digital output / tristate	SDI data output (tristate when CS is low)
Vcc	15	Supply pad	Positive supply voltage
GND	16		Negative supply voltage

## 5 Absolute Maximum Ratings

Stresses beyond those listed in [Table 3](#) may cause permanent damage to the device. These are stress ratings only, and functional operation of the device at these or any other conditions beyond those indicated in [Electrical Characteristics on page 8](#) is not implied. Exposure to absolute maximum rating conditions for extended periods may affect device reliability.

Table 3. Absolute Maximum Ratings

Parameter	Min	Max	Units	Comments
<b>Electrical Parameters</b>				
DC supply voltage (V <sub>DD</sub> )	-0.5	5	V	
Input pin voltage (V <sub>IN</sub> )	-0.5	5	V	
Input current (latch up immunity) (I <sub>SOURCE</sub> )	-100	100	mA	Norm: Jedec 78
<b>Electrostatic Discharge</b>				
Electrostatic discharge (ESD)	±2		kV	Norm: MIL 883 E method 3015 (HBM)
<b>Continuous Power Dissipation</b>				
Total power dissipation (all supplies and outputs) (P <sub>t</sub> )		0.07	mW	
<b>Temperature Ranges and Storage Conditions</b>				
Storage temperature (T <sub>strg</sub> )	-65	150	°C	
Package body temperature (T <sub>body</sub> )		260	°C	Norm: IPC/JEDEC J-STD-020 <i>The reflow peak soldering temperature (body temperature) is specified according IPC/JEDEC J-STD-020 "Moisture/Reflow Sensitivity Classification for Non-hermetic Solid State Surface Mount Devices".</i>
Humidity non-condensing	5	85	%	

## 6 Electrical Characteristics

Table 4. Operating Conditions

Symbol	Parameter	Conditions	Min	Typ	Max	Units
AVDD	Positive supply voltage		2.4	3	3.6	V
AVSS	Negative supply voltage		0		0	V
TAMB	Ambient temperature		-40		85	°C

Table 5. DC/AC Characteristics for Digital Inputs and Outputs

Symbol	Parameter	Conditions	Min	Typ	Max	Units
<b>CMOS Input</b>						
V <sub>IH</sub>	High level input voltage		0.6 * V <sub>DD</sub>	0.7 * V <sub>DD</sub>	0.8 * V <sub>DD</sub>	V
V <sub>IL</sub>	Low level input voltage		0.12 * V <sub>DD</sub>	0.2 * V <sub>DD</sub>	0.3 * DV <sub>DD</sub>	V
I <sub>LEAK</sub>	Input leakage current				100	nA
<b>CMOS Output</b>						
V <sub>OH</sub>	High level output voltage	With a load current of 1mA	V <sub>DD</sub> - 0.4			V
V <sub>OL</sub>	Low level output voltage	With a load current of 1mA			V <sub>SS</sub> + 0.4	V
CL	Capacitive load	For a clock frequency of 1 MHz			400	pF
<b>Tristate CMOS Output</b>						
V <sub>OH</sub>	High level output voltage	With a load current of 1mA	V <sub>DD</sub> - 0.4			V
V <sub>OL</sub>	Low level output voltage	With a load current of 1mA			V <sub>SS</sub> + 0.4	V
I <sub>OZ</sub>	Tristate leakage current	to DV <sub>DD</sub> and DV <sub>SS</sub>			100	nA

Table 6. Electrical System Specifications

Symbol	Parameter	Conditions	Min	Typ	Max	Units
<b>Input Characteristics</b>						
R <sub>IN</sub>	AC Input Impedance at 125kHz	In case no antenna damper is set (R1 < 4 >= 0)		2		MΩ
F1max	Maximum Input Frequency Band1			150		kHz
F1min	Minimum Input Frequency Band1			95		kHz
F2max	Maximum Input Frequency Band2			95		kHz
F2min	Minimum Input Frequency Band2			65		kHz
F3max	Maximum Input Frequency Band3			65		kHz
F3min	Minimum Input Frequency Band3			40		kHz
F4max	Maximum Input Frequency Band4			40		kHz
F4min	Minimum Input Frequency Band4			23		kHz
F5max	Maximum Input Frequency Band5			23		kHz
F5min	Minimum Input Frequency Band5			15		kHz



Table 6. Electrical System Specifications

Symbol	Parameter	Conditions	Min	Typ	Max	Units
<b>Current Consumption</b>						
I1CHRC	Current Consumption in standard listening mode with one active channel and RC-oscillator as Clock Generator			2.7		μA
I2CHRC	Current Consumption in standard listening mode with two active channels and RC-oscillator as Clock Generator			4.2		μA
I3CHRC	Current Consumption in standard listening mode with three active channels and RC-oscillator as Clock Generator			5.7		μA
I3CHSCRC	Current Consumption in scanning mode with three active channels and RC-oscillator as Clock Generator			2.7		μA
I3CHOORC	Current Consumption in ON/OFF mode with three active channels and RC-oscillator as Clock Generator	11% Duty Cycle		1.7		μA
		50% Duty Cycle		3.45		
I3CHXT	Current Consumption in standard listening mode with three active channels and crystal oscillator as Clock Generator			6.5	8.9	μA
IDATA	Current Consumption in Preamble detection / Pattern correlation / Data receiving mode (RC-oscillator)	With 125 kHz carrier frequency and 1 kbps data-rate. No load on the output pins.		8.3	12	μA
IBOOST	Additional current consumption per channel if gain boost enabled			150		nA
<b>Input Sensitivity</b>						
SENS1	Input Sensitivity on all channels in the Band1	With 125 kHz carrier frequency, chip in default mode, 4 half bits burst + 4 symbols preamble and single preamble detection		100		μVrms
SENS1B	Input Sensitivity on all channels in the Band1 with 3dB gain boost	With 125 kHz carrier frequency, chip in default mode, 4 half bits burst + 4 symbols preamble and single preamble detection		80		μVrms
SENS2	Input Sensitivity on all channels in the Band2	With 90 kHz carrier frequency, chip in default mode, 4 half bits burst + 4 symbols preamble and single preamble detection		100		μVrms
SENS2B	Input Sensitivity on all channels in the Band2 with 3dB gain boost	With 90 kHz carrier frequency, chip in default mode, 4 half bits burst + 4 symbols preamble and single preamble detection		80		μVrms
SENS3	Input Sensitivity on all channels in the Band3	With 60 kHz carrier frequency, chip in default mode, 4 half bits burst + 4 symbols preamble and single preamble detection		100		μVrms
SENS3B	Input Sensitivity on all channels in the Band3 with 3dB gain boost	With 60 kHz carrier frequency, chip in default mode, 4 half bits burst + 4 symbols preamble and single preamble detection		80		μVrms
SENS4B	Input Sensitivity on all channels in the Band4 with 3dB gain boost	With 30 kHz carrier frequency, chip in default mode, 4 half bits burst + 4 symbols preamble and single preamble detection		80		μVrms
SENS5B	Input Sensitivity on all channels in the Band5 with 3dB gain boost	With 18 kHz carrier frequency, chip in default mode, 4 half bits burst + 4 symbols preamble and single preamble detection		80		

Table 6. Electrical System Specifications

Symbol	Parameter	Conditions	Min	Typ	Max	Units
<b>Channel Settling Time</b>						
TSAMP	Amplifier settling time			250		$\mu$ s
<b>Crystal Oscillator</b>						
FXTAL	Frequency	Crystal dependent	25	32.768	45	kHz
TXTAL	Start-up Time				1	s
IXTAL	Current consumption			300		nA
<b>External Clock Source</b>						
IEXTCL	Current consumption			0.8		$\mu$ A
FEXTCL	Frequency		25		45	kHz
<b>RC Oscillator</b>						
FRCNCAL	Frequency	If no calibration is performed	25	32.768	45	kHz
FRCCAL32		If calibration with 32.768 kHz reference signal is performed	31	32.768	34.5	
FRCCALMAX		Maximum achievable frequency after calibration		25.8		
FRCCALMIN		Minimum achievable frequency after calibration		45		
TCALRC	Calibration time		65			Periods of reference clock
IRC	Current consumption			650		nA
<b>LC Oscillator</b>						
FLCO <sub>MIN</sub>	Minimum Frequency	L=47mH (Premo: SDTR1103-0108+), C=2.3nF		15		kHz
FLCO <sub>MAX</sub>	Maximum Frequency	L=7.2mH (Premo: SDTR1103-0720+), C=1nF		150		kHz
RPAR <sub>MIN</sub>	Minimum Eq. Parallel			10		k $\Omega$
<b>Tuning Caps</b>						
LF1Ptuning	Capacitance	Maximum internal capacitance (in step of 1pF) on LF1P		32		pF
LF2Ptuning		Maximum internal capacitance (in step of 1pF) on LF2P		32		pF
LF3Ptuning		Maximum internal capacitance (in step of 1pF) on LF3P		32		pF

## 7 Typical Operating Characteristics

Figure 6. Sensitivity over Voltage and Temperature

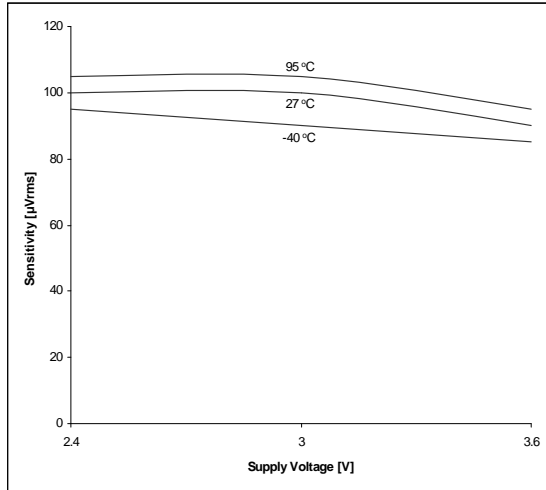

Figure 7. Sensitivity over RSSI

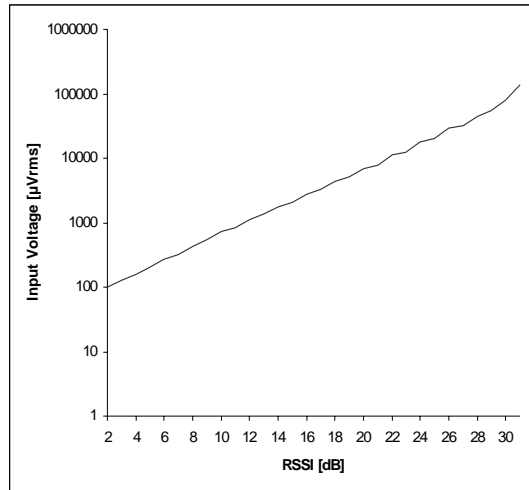

Figure 8. RC-Oscillator Frequency over Voltage (calibr.)

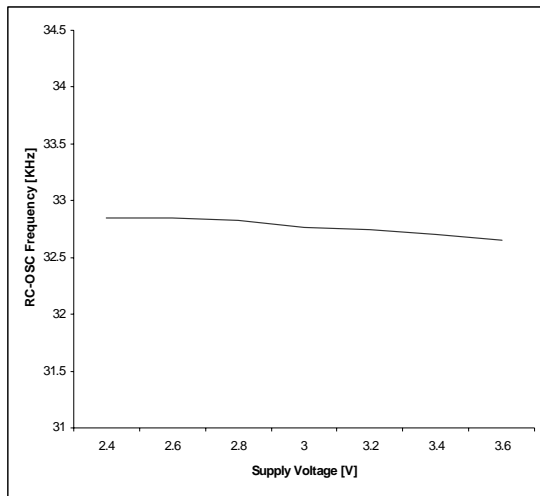
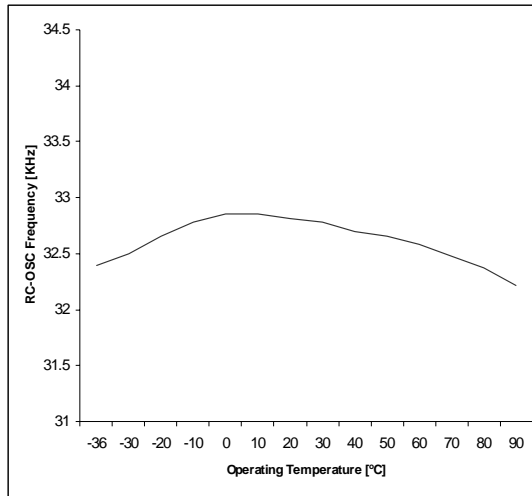

Figure 9. RC-Oscillator Frequency over Temperature (calibr.)



## 8 Detailed Description

The AS3933 is a three-dimensional low power low-frequency wakeup receiver. The AS3933 is capable of detecting the presence of an inductive coupled carrier and can extract the envelope of the On-Off-Keying (OOK) modulated carrier. In case the carrier is Manchester coded, the clock can be recovered from the received signal and the data can be correlated with a programmed pattern. If the detected pattern corresponds to the stored one, a wake-up signal (IRQ) is risen up. The pattern correlation can be disabled; in this case and the wake-up detection is based only on the frequency detection.

The AS3933 is made up of three independent receiving channels, one envelop detector, one data correlator, one Manchester decoder, 19 programmable registers with the main logic and a Clock Generator.

The digital logic can be accessed by an SPI. The Clock Generator can be based on a crystal oscillator, or an internal RC-oscillator or an external clock. In case the RC-oscillator is used to improve its accuracy, a calibration can be performed.

The internal LC-oscillator can deliver the antenna's oscillation frequency for each channel and the internal tuning capacitor bank can provide fine tuning.

The Internal RC-oscillator can be calibrated either over SPI or using the internal algorithm based on the antenna resonance frequency.

Figure 10. Block Diagram of the LF Wakeup Receiver AS3933

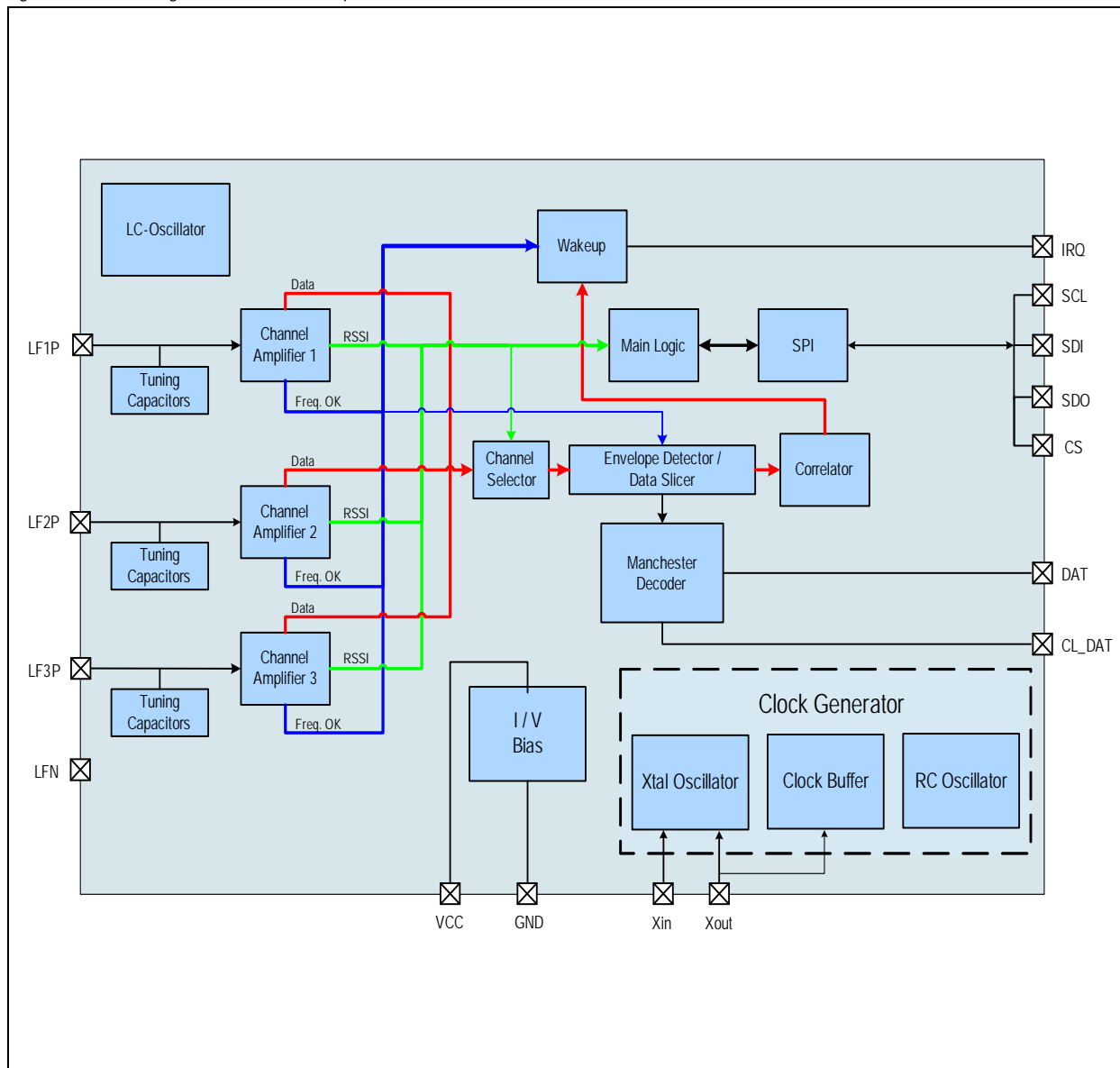

AS3933 needs the following external components:

- Power supply capacitor: CBAT – 100 nF
- 32.768 kHz crystal with its two pulling capacitors: XTAL and CL – (it is possible to omit these components if the internal RC oscillator is used instead of the crystal oscillator).
- One, two, or three LC resonators according to the number of used channels.

In case the internal RC-oscillator is used (no crystal oscillator is mounted), the pin XIN has to be connected to the supply, while pin XOUT should stay floating. Application diagrams with and without crystal are shown in [Figure 1](#), [Figure 2](#) and [Figure 3](#).

## 8.1 Operating Modes

The diagram in [Figure 11](#) shows how the AS3933 operates.

Figure 11. Operating Modes Flow Chart

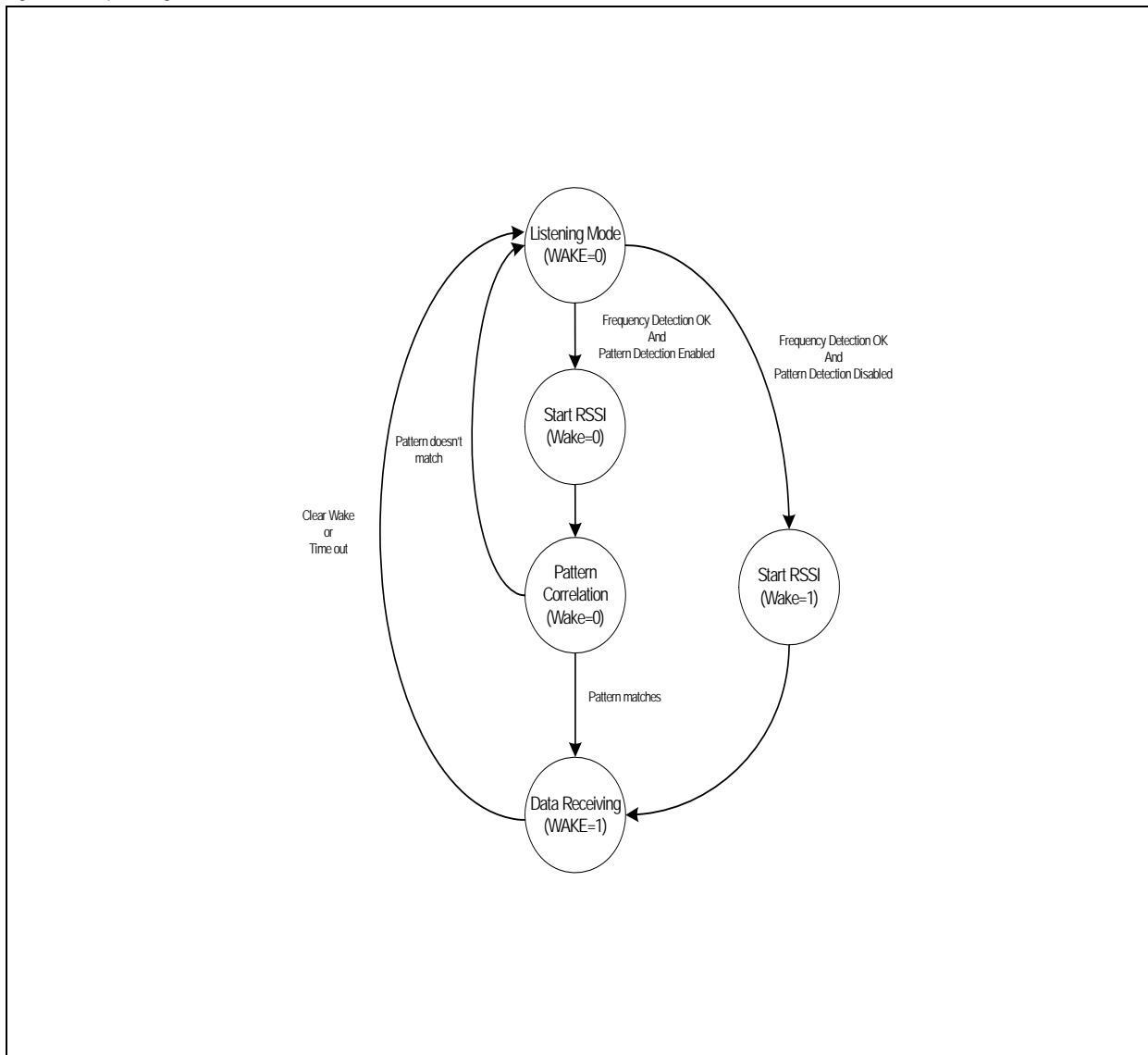

### 8.1.1 Listening Mode

In listening mode, the chip is active and looks continuously for the presence of the carrier on the input of all active channels. In this mode, only the active channel amplifiers and the Clock Generator are running. In case the carrier is detected, then the RSSI measurements get started on all three channels and the result is stored in the memory.

If the three dimensional detection is not required, then it is possible to deactivate one or more channels. In case only two channels are required, then the deactivated channel must be the number three; while in case only one channel is needed, then the active channel must be the number one.

Inside the listening mode, it is possible to distinguish the following three low power sub modes:

**Standard Listening Mode.** All channels are active at the same time.

**Scanning Mode (Low Power Mode 1).** In this sub-mode, a time slot  $T=1\text{ms}$  is defined and in each time slot only one channel can be active. As shown in Figure 12 when a certain time slot is over, the current active channel is switched off and the next channel becomes active and so on. If, for example all three channels are enabled, in the first time slot the only active channel is the number one. When the first time slot is over, the channel one is switched off and the channel two becomes active. During the third time slot, the channel three is active while the other two are off. This channel rotation starts back from the channel one and goes on until the presence of the carrier is detected by any channel. The Scanning mode (channel rotation) is managed internally by the AS3933 and doesn't need any activity from the host system (MCU). As soon as one channel detects the frequency, all three channels become immediately active at the same time. The AS3933 can perform a simultaneous multidirectional evaluation (on all three channels) of the field and evaluate which channel has the strongest RSSI. The channel with the highest RSSI will be put through to the demodulator. In this way it is possible to perform multidirectional monitoring of the field with a current consumption of a single channel, keeping the sensitivity as good as if all channels are active at the same time.

Figure 12. Scanning Mode

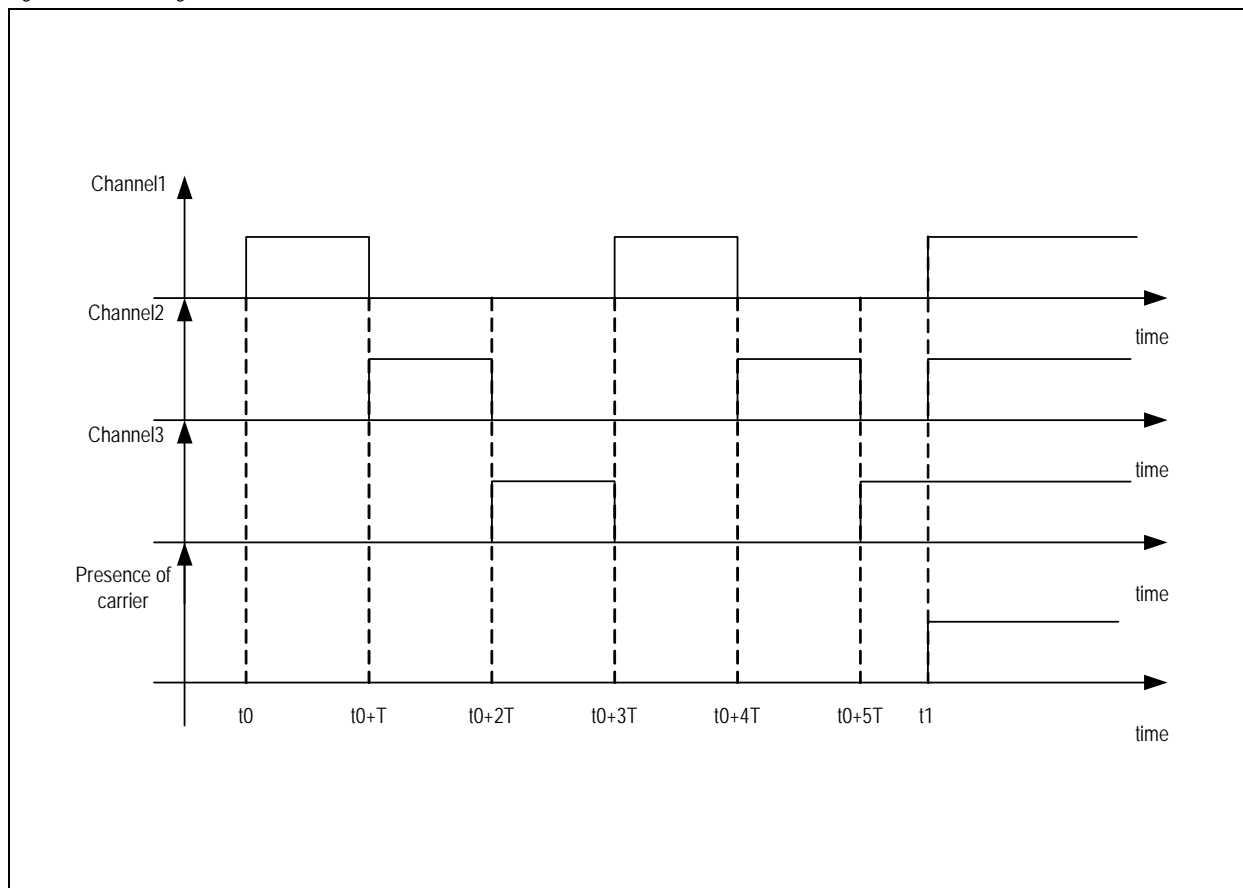

**ON/OFF Mode (Low Power Mode 2).** In this low power sub-mode the chip sets the receiving channels in polling mode; all active channels are on at the same time only for a certain time  $T$  (where  $T$  is 1 ms). The off-time can be defined with the bits  $R4\langle 7:6 \rangle$ . If, for example,  $R4\langle 7:6 \rangle = 11$  (see Table 9) the active channels will be 1ms ON and 8ms OFF.

Figure 13. ON/OFF Mode

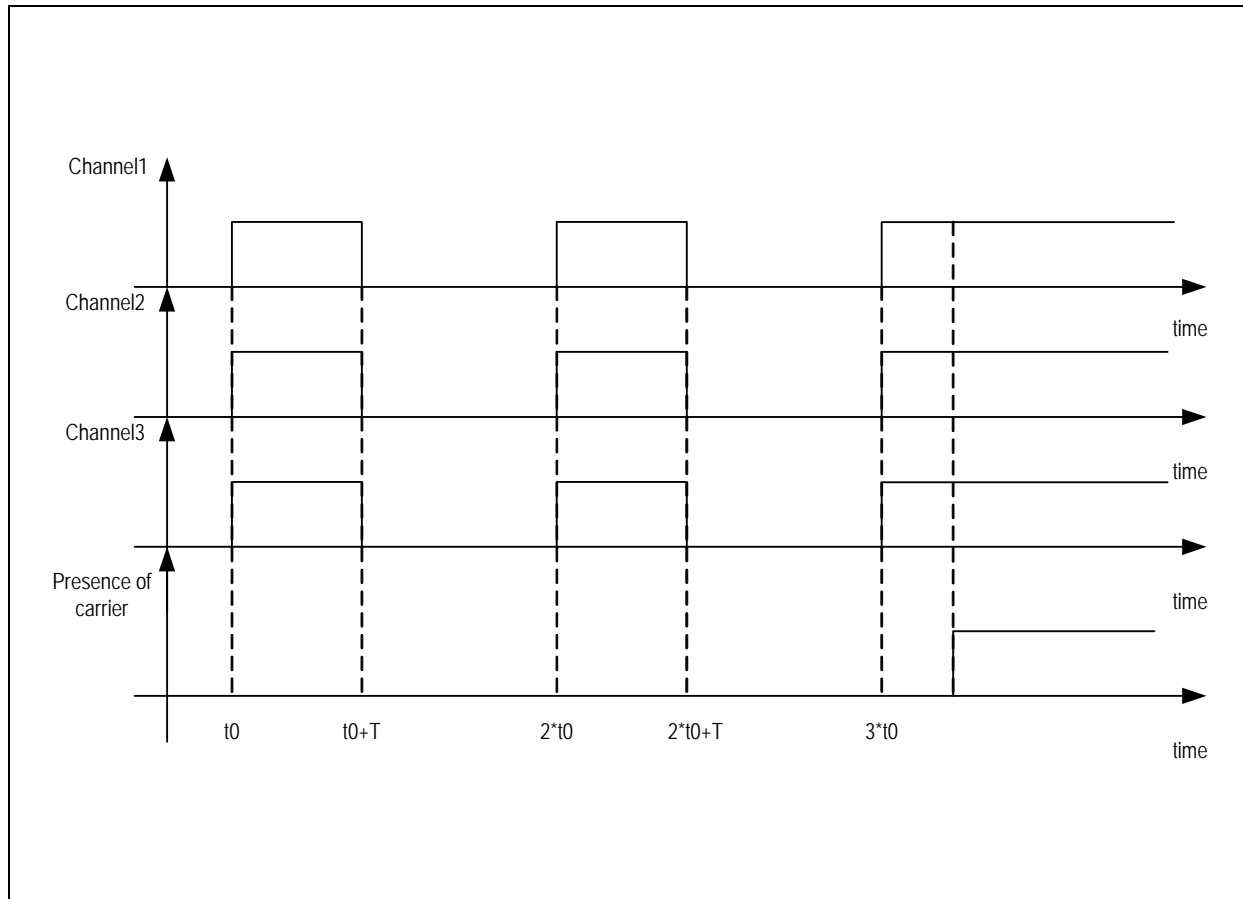

### 8.1.2 Artificial Wakeup

For each of these sub modes it is possible to enable a further feature called Artificial Wake-up. The Artificial Wake-up is a counter based on the used Clock Generator. Three bits define a time window (see **R8<2:0>**). If no activity is seen within this time window, the chip will produce an interrupt on the WAKE pin that lasts 128  $\mu$ s. With this interrupt the microcontroller ( $\mu$ C) can get feedback on the surrounding environment (e.g. read the false wakeup register, see [Correlator \(page 27\)](#) register **R13<7:0>**) and/or take actions in order to change the setup.

### 8.1.3 Preamble Detection / Pattern Correlation

The chip can go in to this mode after detecting a LF carrier only if the data correlation is enabled (**R1<1>=1**). The correlator searches first for preamble bits and then for data pattern. The paragraph 8.6.2 describes how the protocol can be implemented. Should the pattern correlation be disabled (**R1<1>=0**), the AS3933 goes directly in Data receiving mode (see paragraph 8.1.4).

If the received pattern matches, then the wake-up interrupt is displayed on the WAKE output (Wake goes high) and the chip goes in Data receiving mode. If the pattern fails, then the internal wake-up (on all active channels) is terminated and no interrupt is produced.

During the pattern correlation it is possible to display the data (received preamble + pattern) if the bit **R0<6>=1**, otherwise, this will be masked. In case the user decides to mask the data before the generation of the interrupt on the pin WAKE, then the data will be displayed only after the generation of the interrupt.

### 8.1.4 Data Receiving

The user can enable this mode allowing the pattern correlation or just on the base of the frequency detection. In this mode the chip can be retained a normal OOK receiver. The data is provided on the DAT pin and in case the Manchester decoder is enabled (see **R1<3>**), the recovered clock is present on the CL\_DAT. It is possible to set the chip back to listening mode either with a direct command CLEAR\_WAKE (see [Table 13](#)) or by using the timeout feature. This feature automatically sets the chip back to listening mode after a certain time defined by the bits **R7<7:5>**.

## 8.2 System and Block Specification

### 8.2.1 Register Table

Table 7. Register Table

	7	6	5	4	3	2	1	0
R0	PATT32	DAT_MASK	ON_OFF	MUX_123	EN_A2	EN_A3	EN_A1	
R1	ABS_HY	AGC_TLIM	AGC_UD	ATT_ON	EN_MANCH	EN_PAT2	EN_WPAT	EN_XTAL
R2	S_ABS	EN_EXT_CLK	G_BOOST	Reserved			S_WU1<1:0>	
R3	HY_20m	HY_POS	FS_SLC<2:0>			FS_ENV<2:0>		
R4	T_OFF<1:0>		R_VAL<1:0>		GR<3:0>			
R5	PATT2B<7:0>							
R6	PATT1B<7:0>							
R7	T_OUT<2:0>			T_HBIT<4:0>				
R8	BAND_SEL			T_AUTO<2:0>				
R9	BLOCK_AGC	Reserved						
R10	n.a.			RSSI1<4:0>				
R11	n.a.			RSSI3<4:0>				
R12	n.a.			RSSI2<4:0>				
R13	F_WAKE							
R14	RC_CAL_KO	RC_CAL_OK	RC_OSC_TAPS					
R15	n.a.			LC_OSC_KO	LC_OSC_OK	n.a.		
R16	CLOCK_GEN_DIS	n.a.	RC_OSC_MIN	RC_OSC_MAX	n.a.	LC_OSC_MUX		
R17	n.a.			CAP__CH1				
R18	n.a.			CAP__CH2				
R19	n.a.			CAP__CH3				

### 8.2.2 Register Table Description and Default Values

Table 8. Default Values of Registers

Register	Name	Type	Default Value	Description
R0<7>	PAT32	W	0	Pattern extended to 32 bits (PAT32=0 16 bits, PAT32=1 32bits)
R0<6>	DAT_MASK	W	0	Masks data on DAT pin before wakeup happens
R0<5>	ON_OFF	W	0	On/Off operation mode. (Duty-cycle defined in the register R4<7:6>)
R0<4>	MUX_123	W	0	Scan mode enable
R0<3>	EN_A2	W	1	Channel 2 enable
R0<2>	EN_A3	W	1	Channel 3 enable
R0<1>	EN_A1	W	1	Channel 1 enable
R0<0>		W	0	Reserved
R1<7>	ABS_HY	W	0	Enable Data slicer absolute reference
R1<6>	AGC_TLIM	W	0	AGC acting only on the first carrier burst
R1<5>	AGC_UD	W	1	AGC operating in both direction (up-down)



Table 8. Default Values of Registers

Register	Name	Type	Default Value	Description	
R1<4>	ATT_ON	W	0	Antenna damper enable	
R1<3>	EN_MANCH	W	0	Manchester decoder enable	
R1<2>	EN_PAT2	W	0	Double wakeup pattern correlation	
R1<1>	EN_WPAT	W	1	Correlator enable	
R1<0>	EN_XTAL	W	1	Crystal oscillator enable	
R2<7>	S_ABSH	W	0	Data slicer absolute threshold reduction	
R2<6>	EN_EXT_CLK	W	0	Enables external clock generator	
R2<5>	G_BOOST	W	0	+3dB Amplifier Gain Boost (G_BOOST=1)	
R2<4:2>			000	Reserved	
R2<1:0>	S_WU1	W	00	Tolerance setting for the stage wakeup (see Table 16)	
R3<7>	HY_20m	W	0	Data slicer hysteresis if HY_20m = 0 then comparator hysteresis = 40mV if HY_20m = 1 then comparator hysteresis = 20mV	
R3<6>	HY_POS	W	0	Data slicer hysteresis only on positive edges (HY_POS=0, hysteresis on both edges, HY_POS=1, hysteresis only on positive edges)	
R3<5:3>	FS_SCL	W	100	Data slices time constant (see Table 21)	
R3<2:0>	FS_ENV	W	000	Envelop detector time constant (see Table 20)	
R4<7:6>	T_OFF	W	00	Off time in ON/OFF operation mode	
				T_OFF=00	1ms
				T_OFF=01	2ms
				T_OFF=10	4ms
				T_OFF=11	8ms
R4<5:4>	D_RES	W	01	Antenna damping resistor (see Table 19)	
R4<3:0>	GR	W	0000	Gain reduction (see Table 18)	
R5<7:0>	TS2	W	01101001	2nd Byte of wakeup pattern	
R6<7:0>	TS1	W	10010110	1st Byte of wakeup pattern	
R7<7:5>	T_OUT	W	000	Automatic time-out (see Table 23)	
R7<4:0>	T_HBIT	W	01011	Bit rate definition (see Table 22)	
R8<7:5>	BAND_SEL	W	000	Band selection (see Table 15)	
R8<2:0>	T_AUTO	W	000	Artificial wake-up	
				T_AUTO=000	No artificial wake-up
				T_AUTO=001	1 sec
				T_AUTO=010	5 sec
				T_AUTO=011	20 sec
				T_AUTO=100	2 min
				T_AUTO=101	15min
				T_AUTO=110	1 hour
				T_AUTO=111	2 hour
R9<7>	BLOCK_AGC	W	0	Disables AGC	

Table 8. Default Values of Registers

Register	Name	Type	Default Value	Description
R9<6:0>			000000	Reserved
R10<4:0>	RSSI1	R		RSSI channel 1
R11<4:0>	RSSI3	R		RSSI channel 3
R12<4:0>	RSSI2	R		RSSI channel 2
R13<7:0>	F_WAK	WR		False wakeup register
R14<7>	RC_CAL_KO	R		Unsuccessful RC calibration
R14<6>	RC_CAL_OK	R		Successful RC calibration
R14<5:0>	RC_OSC_TAPS	R		RC-Oscillator taps setting
R15<4>	LC_OSC_OK	R		LC-Oscillator working
R15<3>	LC_OSC_KO	R		LC-Oscillator not working
R16<7>	CLOCK_GEN_DIS	W	0	The Clock Generator output signal displayed on CL_DAT pin
R16<6>	LC_OSC_DIS	W	0	The LC-oscillator output signal displayed on DAT pin
R16<5>	RC_OSC_MIN	W	0	Sets the RC-oscillator to minimum frequency
R16<4>	RC_OSC_MAX	W	0	Sets the RC-oscillator to maximum frequency
R16<2>	LC_OSC_MUX3	W	0	Connects LF3P to the LCO
R16<1>	LC_OSC_MUX2	W	0	Connects LF2P to the LCO
R16<0>	LC_OSC_MUX1	W	0	Connects LF1P to the LCO
R17<4:0>	CAPS_CH1	W	00000	Capacitor banks on the channel1
R18<4:0>	CAPS_CH1	W	00000	Capacitor banks on the channel2
R19<4:0>	CAPS_CH1	W	00000	Capacitor banks on the channel3

### 8.2.3 Serial Peripheral Interface (SPI)

This 4-wire interface is used by the Microcontroller ( $\mu\text{C}$ ) to program the AS3933. The maximum clock operation frequency of the SPI is 6MHz.

Table 9. Serial Peripheral Interface (SPI) Pins

Name	Signal	Signal Level	Description
CS	Digital Input	CMOS	Chip Select
SIN	Digital Input	CMOS	Serial Data input for writing registers, data to transmit and/or writing addresses to select readable register
SOUT	Digital Output	CMOS	Serial Data output for received data or read value of selected registers
SCLK	Digital Input	CMOS	Clock for serial data read and write

**Note:** SDO is set to tristate if CS is low. In this way more than one device can communicate on the same SDO bus.

**SPI Command Structure.** To program the SPI the CS signal has to go high. A SPI command is made up by a two bytes serial command and the data is sampled on the falling edge of SCLK. Table 10 shows how the command looks like, from the MSB (B15) to LSB (B0). The command stream has to be sent to the SPI from the MSB (B15) to the LSB (B0).

Table 10. SPI Command Structure

Mode		Register Address / Direct Command						Register Data							
B15	B14	B13	B12	B11	B10	B9	B8	B7	B6	B5	B4	B3	B2	B1	B0

The first two bits (B15 and B14) define the operating mode. There are three modes available (write, read, direct command) plus one spare (not used), as shown in [Table 11](#).

Table 11. SPI Command Structure

B15	B14	Mode
0	0	WRITE
0	1	READ
1	0	NOT ALLOWED
1	1	DIRECT COMMAND

In case a write or read command happens the next 5 bits (B13 to B9) define the register address which has to be written respectively read, as shown in [Table 12](#).

Table 12. SPI Command Structure

B13	B12	B11	B10	B9	B8	Read / Write Register
0	0	0	0	0	0	R0
0	0	0	0	0	1	R1
0	0	0	0	1	0	R2
0	0	0	0	1	1	R3
0	0	0	1	0	0	R4
0	0	0	1	0	1	R5
0	0	0	1	1	0	R6
0	0	0	1	1	1	R7
0	0	1	0	0	0	R8
0	0	1	0	0	1	R9
0	0	1	0	1	0	R10
0	0	1	0	1	1	R11
0	0	1	1	0	0	R12
0	0	1	1	0	1	R13
0	0	1	1	1	0	R14
0	0	1	1	1	1	R15
0	1	0	0	0	0	R16
0	1	0	0	0	1	R17
0	1	0	0	1	0	R18
0	1	0	0	1	1	R19

The last 8 bits are the data that has to be written respectively read. A CS toggle high-low-high terminates the command mode.

If a direct command is sent (B15-B14=11) the bits from B13 to B9 defines the direct command while the last 8 bits are omitted. [Table 13](#) shows all possible direct commands:

Table 13. List of Direct Commands

COMMAND_MODE	B13	B12	B11	B10	B9	B8
clear_wake	0	0	0	0	0	0
reset_RSSI	0	0	0	0	0	1
Calib_RCosc	0	0	0	0	1	0
clear_false	0	0	0	0	1	1
preset_default	0	0	0	1	0	0
Calib_RCO_LC	0	0	0	1	0	1

All direct commands are explained below:

- clear\_wake: clears the wake state of the chip. In case the chip has woken up (WAKE pin is high) the chip is set back to listening mode
- reset\_RSSI: resets the RSSI measurement.
- Calib\_RCosc: starts the trimming procedure of the internal RC oscillator (see page 21)
- clear\_false: resets the false wakeup register (R13=00)
- preset\_default: sets all register in the default mode, as shown in Table 8
- Calib\_RCO\_LC: calibration of the RC-oscillator with the external LC tank (see page 22)

**Writing of Data to Addressable Registers (WRITE Mode).** The SPI is sampled at the falling edge of CLK (as shown in the following diagrams).

A CS toggling high-low-high indicates the end of the WRITE command after register has been written. The following example shows a write command.

Figure 14. Writing of a Single Byte (falling edge sampling)

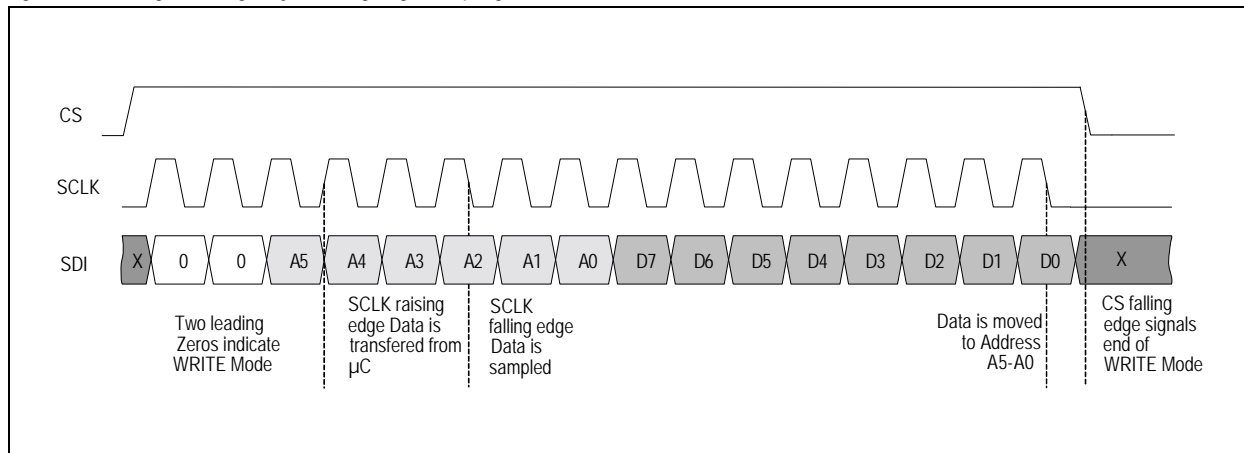
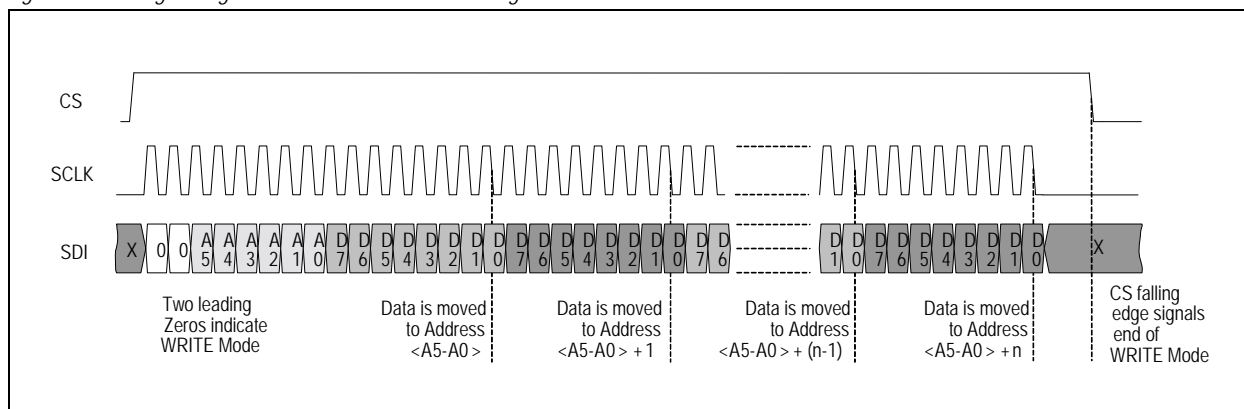

Figure 15. Writing of Register Data with Auto-Incrementing Address



**Reading of Data from Addressable Registers (READ Mode).** Once the address has been sent through SPI, the data can be fed through the SDO pin out to the microcontroller.

A CS LOW toggling high-low-high has to be performed after finishing the read mode session, in order to indicate the end of the READ command and prepare the Interface to the next command control Byte.

To transfer bytes from consecutive addresses, SPI master has to keep the CS signal high and the SCLK clock has to be active as long as data need to be read.

Figure 16. Reading of Single Register Byte

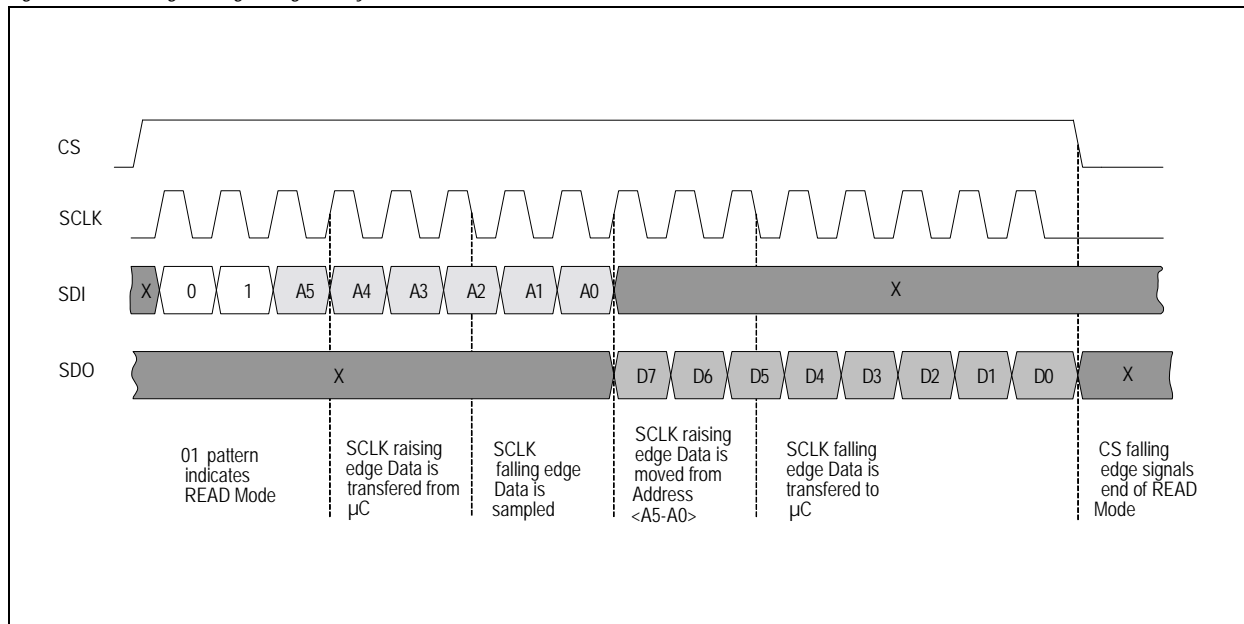
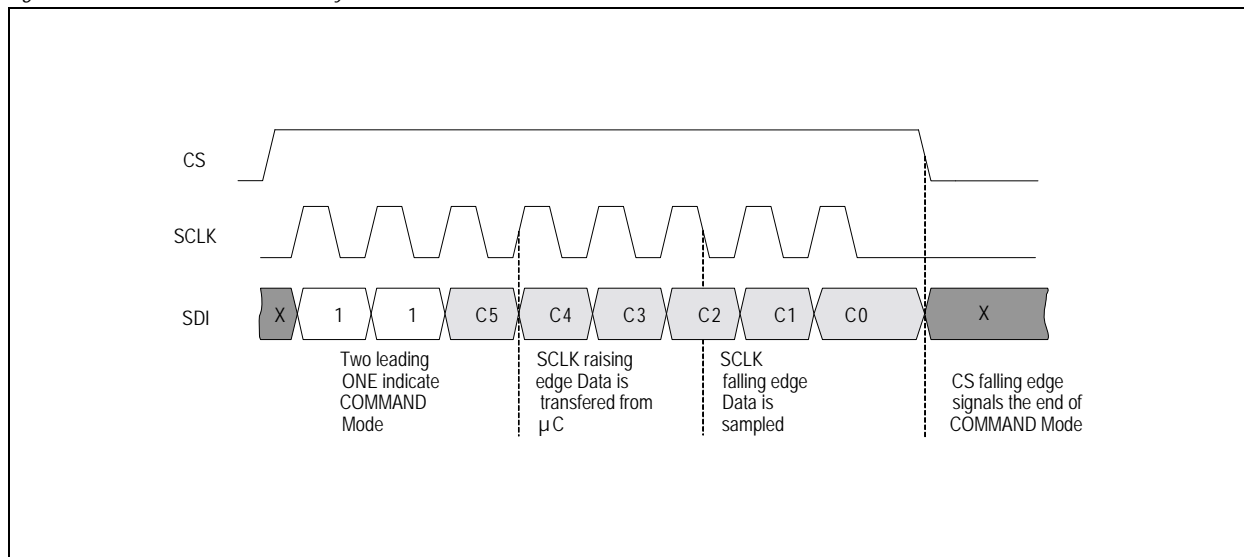

Figure 17. Send Direct COMMAND Byte



## 8.2.4 SDI Timing

Table 14. SDI Timing Parameters

Symbol	Parameter	Conditions	Min	Typ	Max	Units
TCSCl	Time CS to Sampling Data		150			ns
TDCLK	Time Data to Sampling Data		100			ns
THCL	SCL High Time		70			ns
TCL	SCL period		166			ns
TCLKCS	Time Sampling Data to CS down		150			ns
TCST	CS Toggling time		500			ns

Figure 18. SDI Timing Diagram

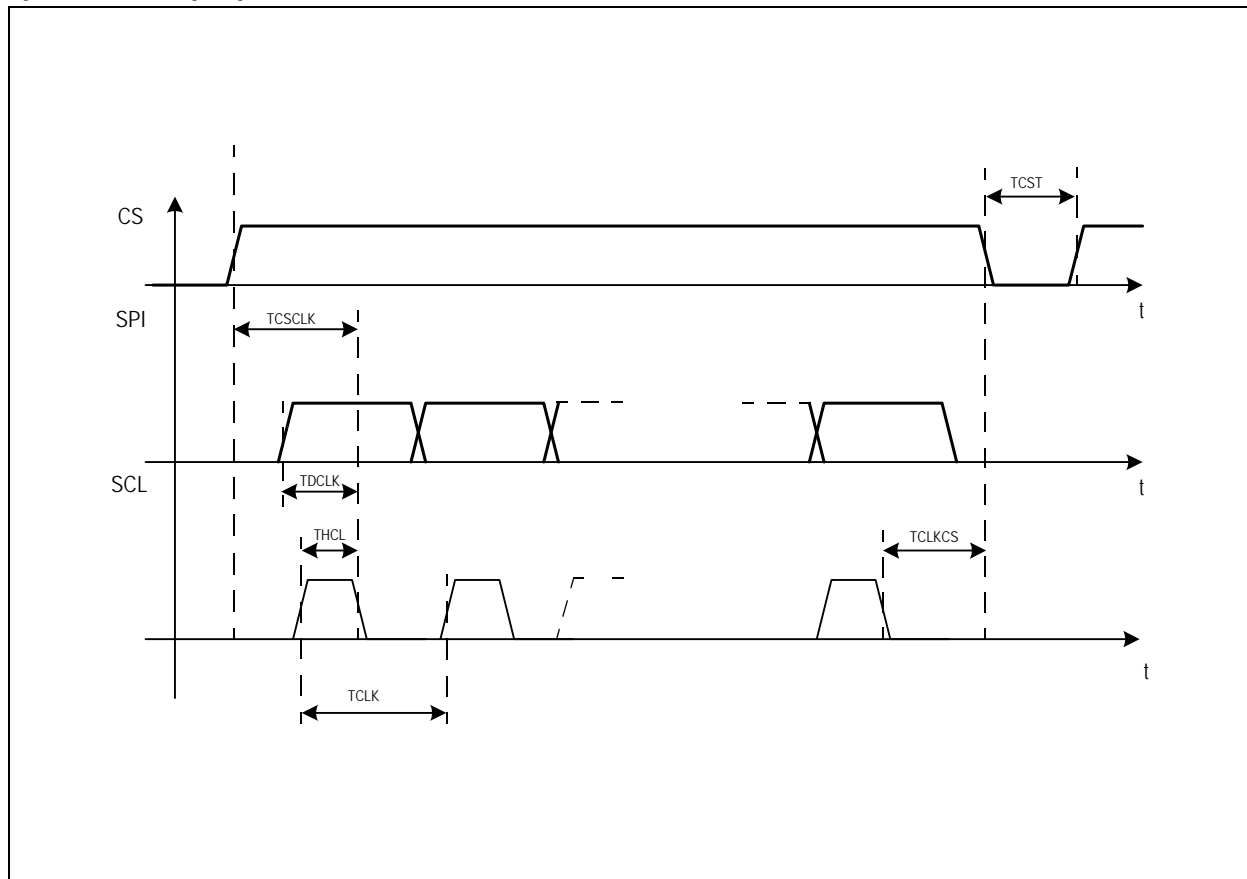

## 8.3 Channel Amplifier, Frequency Detector and RSSI

Each of the 3 channels consists of a variable gain amplifier (VGA) with automatic gain control (AGC) and a frequency detector. When the AS3933 is in listening mode (waiting for RF signal) the gain of all channel amplifiers is set to maximum. The frequency detector counts the zero crossing of the amplified RF signal to detect the presence of the wanted carrier. As soon as the carrier is detected the AGC is enabled, the gain of the VGA is reduced and set to the right value. The RSSI (Received Signal Strength Indicator) represents how strong the input signal is and it is the inverse representation of the gain of the VGA. In fact, if for example the input signal is very strong the AGC will reduce the gain of the VGA. The gain reduction will correspond to a big RSSI, as it is the inverse of the gain setting of the VGA (small gain corresponds to a big RSSI and vice versa).

The AS3933 is a pretty wide LF wakeup receiver and can work between 15 kHz and 150 kHz. Once the carrier frequency has been chosen the user must set the amplifier working in the appropriate frequency band using the bits R8<7:5>, as described in the [Table 15](#).

It is possible to boost the gain of the amplifiers for +3dB with an improvement of the sensitivity, as shown in the [Table 6](#) ( $R2<5>=1$ ). The gain boost will increase the current consumption of 100nA (typ) per channel. In case the lowest frequency band is used (15kHz – 20 kHz) the gain boost is automatically enabled from the logic.

It is possible to enable/disable individual channels, in case not all three channels are needed. This enables to reduce the current consumption by 1.5  $\mu$ A (typ) per channel.

### 8.3.1 Frequency Detector / RSSI / Channel Selector

The frequency detection is based on a zero crossing counter and uses the Clock Generator as time base. This counter counts the zero crossing of the input signal within a time window defined by the clock generator and if it matches to the expected value it enabled the AGC (the RSSI measurement can get started). The Clock Generator can be based either on the internal RC-oscillator or on the Crystal oscillator or on the external clock source. The details on the choice of the Clock Generator are discussed in the [Section 8.8](#). The Clock Generator generates time windows equal to N times its period, where N depends on the operating frequency band, as shown in the [Table 15](#).

*Table 15. Bit Setting for the Operating Frequency Range and Time Windows Generation for the Frequency Detection*

R8<7>	R8<6>	R8<5>	N	Operating Frequency Range [kHz]
0	0	0	4	95-150
0	0	1	6	65-95
0	1	0	10	40-65
0	1	1	18	23-40
1	1	1	14	15-23

The frequency detection is successful if in two consecutive time windows the zero threshold counter detects M zero crossing, where M depends also on the operating frequency range. The frequency detection criteria can be tighter or more relaxed according to the setup described in R2<1:0> (see [Table 15](#)).

*Table 16. Tolerance Settings for Frequency Detection in the Bands 20-150 kHz*

R2<1>	R2<0>	M
0	0	16 $\pm$ 6
0	1	16 $\pm$ 4
1	0	16 $\pm$ 2
1	1	n.a.

[Table 16](#) shows the value of M for the different tolerance settings for the operating frequency bands from 20 to 150kHz. [Table 17](#) shows M in case the operating frequency range is the lowest one (15 to 20 kHz).

*Table 17. Tolerance Settings for Frequency Detection in the Bands 15-20 kHz*

R2<1>	R2<0>	M
0	0	8 $\pm$ 3
0	1	8 $\pm$ 2
1	0	8 $\pm$ 1
1	1	n.a.

The AGC starts working after the frequency detection. At the beginning the gain in the VGA is set to maximum and the AGC reduce it according to the received signal input level. The AGC needs maximum 35 carrier periods to settle, getting a stable RSSI.

The AGC can operate in two modes:

- AGC down only ( $R1<5>=0$ )
- AGC up and down ( $R1<5>=1$ )

If the AGC down only mode is selected, the AGC can only decrease the gain for the whole duration of the data reception; in this mode the system holds the RSSI peak.

When the AGC up and down mode is selected, the RSSI can dynamically follow the input signal strength variation in both directions.

The RSSI is available for all 3 channels at the same time and it is stored in 3 registers (R10<4:0>, R11<4:0>, R12<4:0>). Once the RSSI gets stable (maximum after 35 carrier periods after frequency detection) the channel selector checks which channel receives the strongest signal. The channel selector compares the RSSI on the active channels and freezes the AGC on the channels which have the smaller RSSI. From this time on the AGC is active only on the selected channel. It is possible to set things back having the AGC active on all channels just sending a `clear_wake` (sets the chip back to listening mode) or `reset_RSSI` (resets the AGC) direct command.

Both AGC modes (only down or down and up) can also operate with time limitation. This option allows AGC operation only in time slot of 256µs after the frequency detection (during carrier burst), then the RSSI is frozen till the wake-up or RSSI reset occurs (`clear_wakeup` or `reset_RSSI`).

The RSSI is reset either with the direct command '`clear_wakeup`' or '`reset_RSSI`'. The '`reset_RSSI`' command resets only the VGA setting but does not terminate wake-up frequency detection condition. This means that if the signal is still present the new AGC setting (RSSI) will appear not later than 35 LF carrier periods after the command was received. The AGC setting is reset during data receiving if for duration of 3 Manchester half symbols no carrier is detected. If the wake-up IRQ is cleared the chip will go back to listening mode.

In case the maximum amplification at the beginning is a drawback (e.g. in noisy environment) it is possible to set a smaller starting gain on the amplifier, according to the [Table 18](#). In this way it is possible to reduce the false frequency detection.

Table 18. Bit Setting of Gain Reduction

R4<3>	R4<2>	R4<1>	R4<0>	Gain Reduction
0	0	0	0	no gain reduction
0	0	0	1	n.a.
0	0	1	0 or 1	n.a.
0	1	0	0 or 1	-4dB
0	1	1	0 or 1	-8dB
1	0	0	0 or 1	-12dB
1	0	1	0 or 1	-16dB
1	1	0	0 or 1	-20dB
1	1	1	0 or 1	-24dB

### 8.3.2 Antenna Damper

The antenna damper consists of internal resistor which can be connected in parallel to the external resonator, as shown in the [Figure 19](#) and allows the chip to deal with higher field strength. It is possible to enable the antenna damper with the bit R1<4> and the value of the resistor can be chosen with the bits R4<5:4>. The shunt resistors degrade the quality factor of the external resonator by reducing the signal at the input of the amplifier. In this way the resonator sees a smaller parallel resistance (in the band of interest) which degrades its quality factor in order to increase the linear range of the channel amplifier (the amplifier doesn't saturate in presence of bigger signals). [Table 19](#) shows the bit setup.

Table 19. Antenna Damper Bit Setup

R4<5>	R4<4>	Shunt Resistor (parallel to the resonator at 125 kHz)
0	0	1 kΩ
0	1	3 kΩ
1	0	9 kΩ
1	1	27 kΩ



Figure 19. Antenna Damper

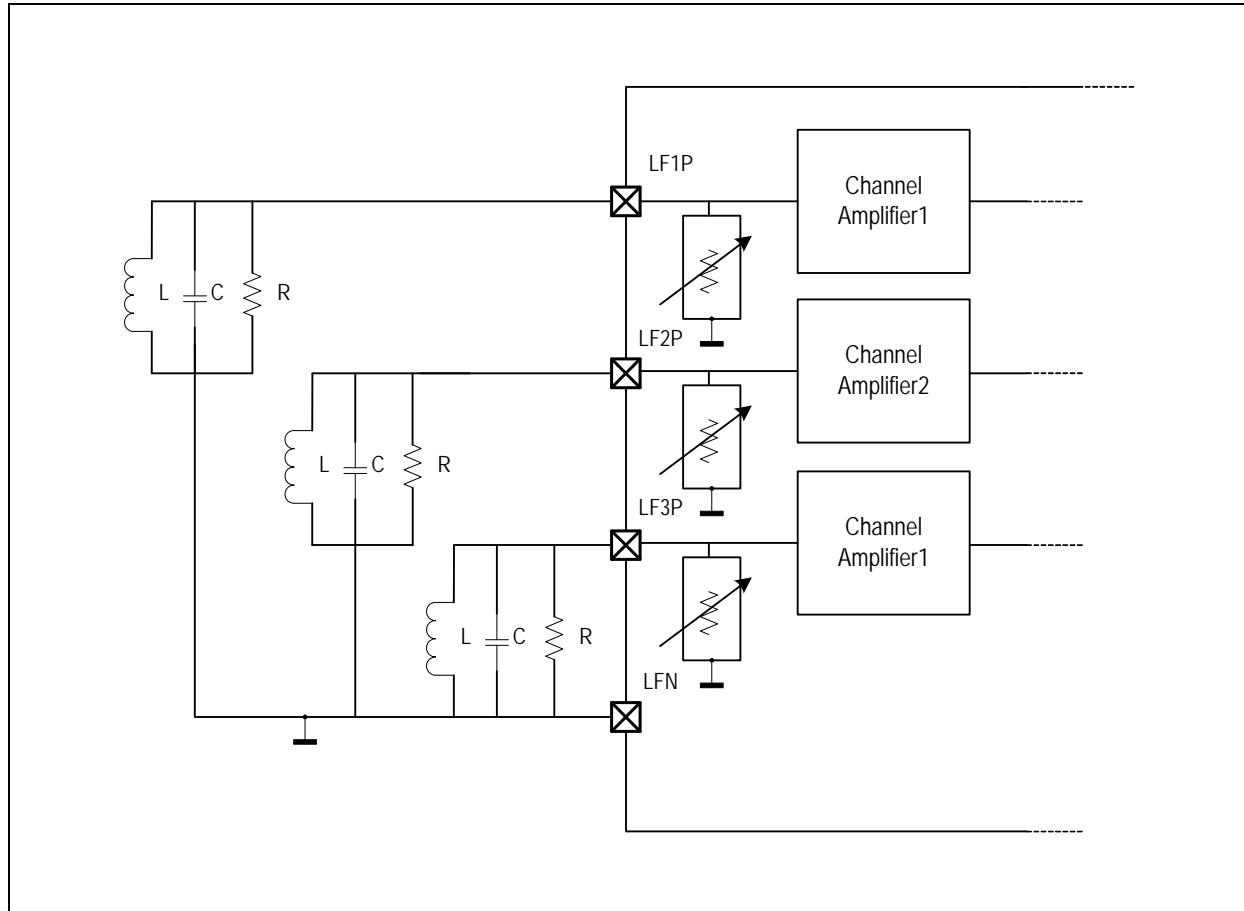

## 8.4 Demodulator / Data Slicer

As soon as the AS3933 detects successfully the frequency and the RSSI has got stable the channel selector compares the RSSI on all active channels and connects the channel amplifier which has the biggest RSSI to the demodulator. The channel selector needs 32 RF carrier periods to take this decision. The output signal (amplified LF carrier) of selected channel is connected to the input of the demodulator.

The demodulator takes the signal to base-band and recovers two signals from the amplified RF signal; a fast and a slow envelop. Those two signals are fed to the data slicer, which is a comparator with programmable hysteresis. At the output of the data slicer are streamed the digital received bits. A concept block diagram is shown in the [Figure 20](#).

Figure 20. Concept Block Diagram

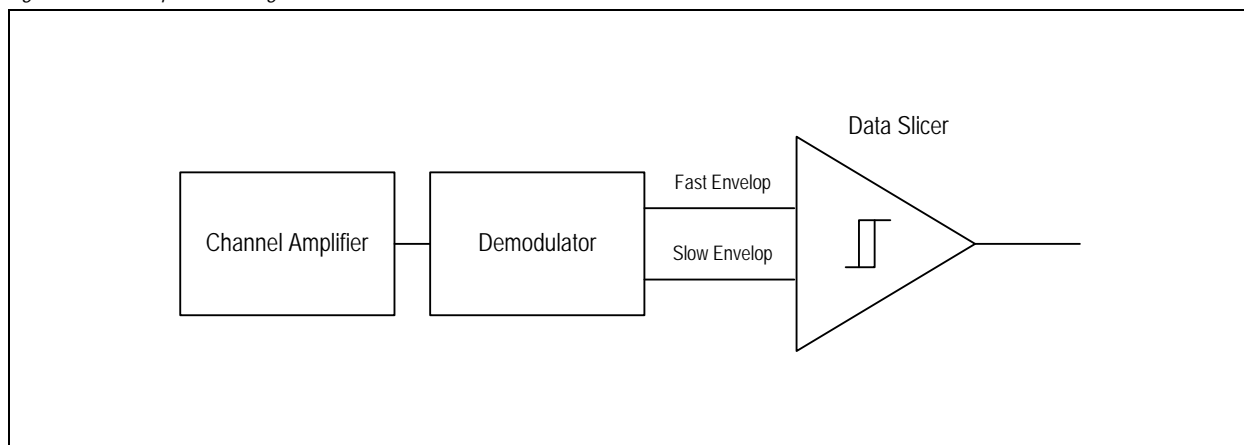
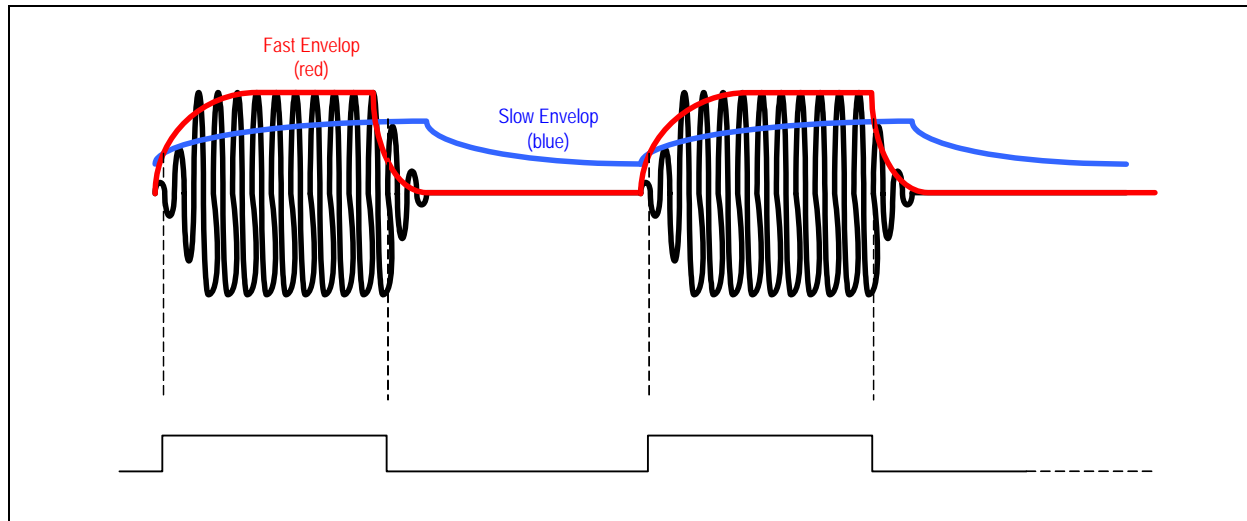

Figure 21. Envelop Detector Signals - Dynamic Threshold



The performance of the demodulator can be optimized according to bit rate and preamble length as described in [Table 20](#) and [Table 21](#).

Table 20. Bit Setup for the Envelop Detector for Different Symbol Rates

R3<2>	R3<1>	R3<0>	Symbol Rate [Manchester symbol/s]
0	0	0	4096
0	0	1	2184
0	1	0	1490
0	1	1	1130
1	0	0	910
1	0	1	762
1	1	0	655
1	1	1	512

If the bit rate gets higher the time constant in the fast envelop must be set to a smaller value (faster), this means that higher noise is injected because of the wider band. The [Table 20](#) is a rough indication of how the envelop detector looks like for different bit rates. By using proper slow envelop settings it is possible to improve the noise immunity paying the penalty of a longer preamble. In fact if the slow envelop signal acts as envelop average signal and the bigger its time constant the better the noise rejection, but the bigger this time constant the longer the preamble must be. [Table 21](#) gives a correlation between slow envelop time constant and minimum required preamble length.

Table 21. Bit Setup for the Data Slicer for Different Preamble Length

R3<5>	R3<4>	R3<3>	Minimum Preamble Length [ms]
0	0	0	0.8
0	0	1	1.15
0	1	0	1.55
0	1	1	1.9
1	0	0	2.3
1	0	1	2.65
1	1	0	3
1	1	1	3.5

**Note:** These times are minimum required, but it is recommended to prolong the preamble.

With the bits R3<6> and R3<7> it is possible to change the hysteresis on the data slicer comparator (only positive, positive negative, 20mV, 40mV).

The slow envelop signal (blue signal in Figure 21) represents the average of the demodulated signal, therefore acts as a reference signal for the data slicer. In case the chosen protocol has a duty cycle far away from 50% (for example in the NRZ protocol there can be several consecutive ones or zeros) the slow envelop signal would not be a stable reference signal for the data slicer. In this case the data slicer can also work with an absolute threshold (R1<7>), as shown in the Figure 22. Should the absolute threshold be enabled the bits R3<2:0> would not influence the performance. It is even possible to reduce the absolute threshold in case the environment is not particularly noisy (R2<7>).

Figure 22. Envelop Detector Signals - Absolute Threshold

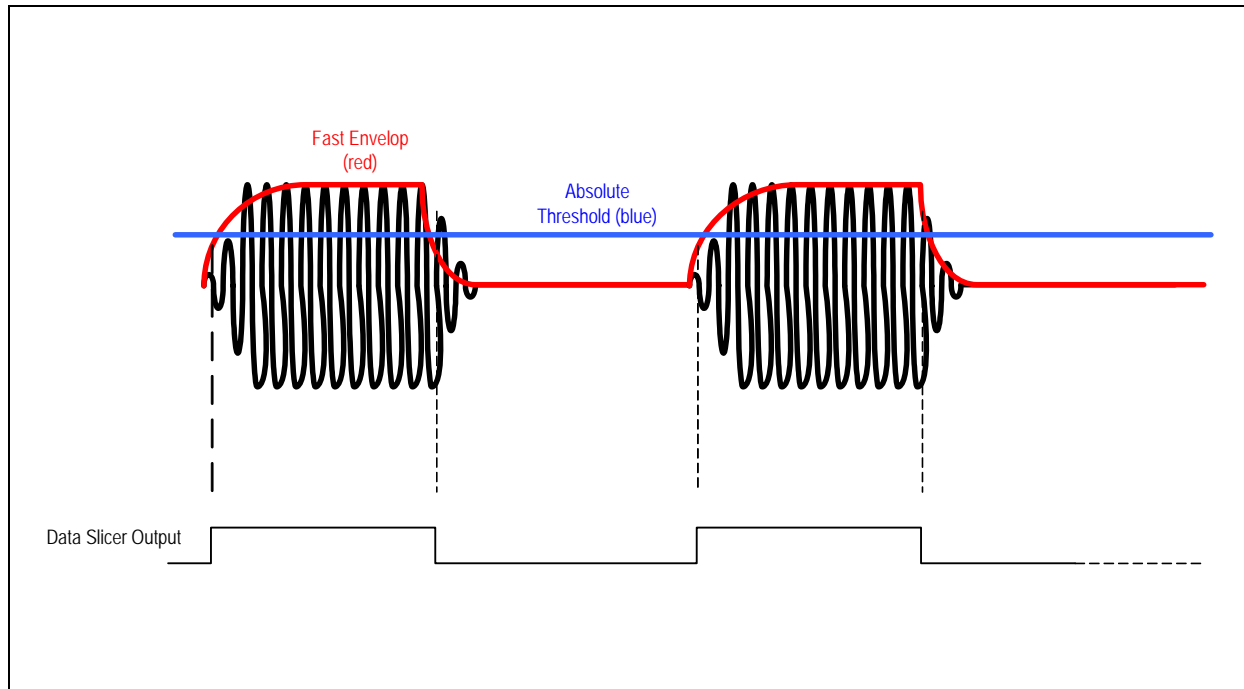

## 8.5 Correlator

In order to prevent that the AS3933 wakes up the host system (MCU) from noise or disturbers (LF transmitter within the field) the internal correlator checks that the bit sequence delivered from the data slicer corresponds to stored pattern. The wanted pattern can be stored in the registers R5<7:0> and R6<7:0>. The data correlation is performed only if the correlator is enabled (R1<1>=1) and can start only after frequency detection.

The pattern correlation is successful (Wake goes high) only if the bits sequence (pattern) and its timing (duration of the single bit) matches.

### 8.5.1 Pattern: Bit and Symbol Definition in Manchester Code

The AS3933 can correlate the incoming pattern without the help of an external unit (MCU). The chosen pattern must be Manchester encoded. In the Manchester code each "Symbol" is defined by a transition (high-to-low for 1 and low-to-high for 0), therefore consists of two "bits". In the Figure 23 it is shown, as an example, how the encoding technique works. In this sequence a simple message made up by 3 symbols (1 0 1) is Manchester encoded. In the Manchester encoded bit stream there can not be three consecutive zeros or ones (in each symbol there is always a transition). This helps the receiver to recover the clock.

Figure 23. Manchester Encoding

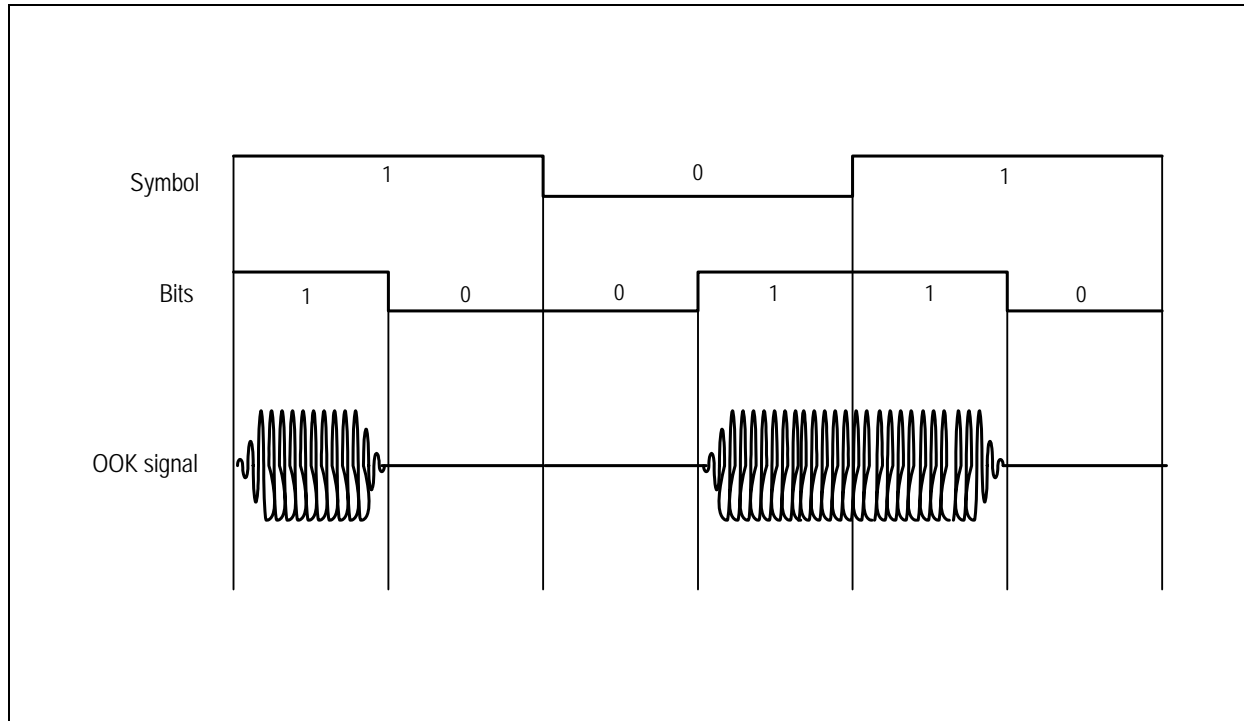

The bit duration is defined in the register R7<4:0> according to the [Table 22](#) as function of the Clock Generator periods.

Table 22. Bit Rate Setup

R7<4>	R7<3>	R7<2>	R7<1>	R7<0>	Bit Duration in Clock Generator Periods
0	0	0	1	1	4
0	0	1	0	0	5
0	0	1	0	1	6
0	0	1	1	0	7
0	0	1	1	1	8
0	1	0	0	0	9
0	1	0	0	1	10
0	1	0	1	0	11
0	1	0	1	1	12
0	1	1	0	0	13
0	1	1	0	1	14
0	1	1	1	0	15
0	1	1	1	1	16
1	0	0	0	0	17
1	0	0	0	1	18
1	0	0	1	0	19
1	0	0	1	1	20
1	0	1	0	0	21

Table 22. Bit Rate Setup

R7<4>	R7<3>	R7<2>	R7<1>	R7<0>	Bit Duration in Clock Generator Periods
1	0	1	0	1	22
1	0	1	1	0	23
1	0	1	1	1	24
1	1	0	0	0	25
1	1	0	0	1	26
1	1	0	1	0	27
1	1	0	1	1	28
1	1	1	0	0	29
1	1	1	0	1	30
1	1	1	1	0	31
1	1	1	1	1	32

The user can define the pattern to correlate in the register R5<7:0> and R6<7:0> and can decide whether the stored pattern is a bit representation (16 Manchester bits corresponds to 8 Symbols) if R0<7>=0 or the symbol representation (16 symbols corresponds to 32 bits) of the pattern if R0<7>=1. The number of different pattern is  $2^{\text{SYM}}$ , where SYM is the number of Manchester symbols. In case the R5<7:0> and R6<7:0> represent the bit sequence of the pattern there are 256 different possible combinations, while in case they are the symbol representation there are 65536 different patterns.

## 8.6 Wakeup Protocol

The AS3933 can support different protocols:

- Frequency detection only (no pattern correlation)
- Single pattern detection
  - 16-bit pattern
  - 32-bit pattern
- Double pattern detection
  - 16-bits pattern
  - 32-bits pattern

The wake-up state can be terminated either by the host system (MCU) with the direct command 'clear\_wake' sent over SPI (see direct command details in [Table 13](#)) or with a time-out option. In case the latter is used the host system (MCU) does not need to take any action to terminate the wake-up state and the chip is set back to listening mode automatically after a predefined time. It is possible to set the duration of the time-out with the register R7<7:5>, as shown in the [Table 23](#).

Table 23. Timeout Setup

R7<7>	R7<6>	R7<5>	Timeout
0	0	0	0 sec
0	0	1	50 msec
0	1	0	100 msec
0	1	1	150 msec
1	0	0	200 msec
1	0	1	250 msec
1	1	0	300 msec
1	1	1	350 msec

### 8.6.1 Wakeup Protocol: Frequency Detection Only

Figure 24. Wakeup Protocol Overview Without Pattern Detection

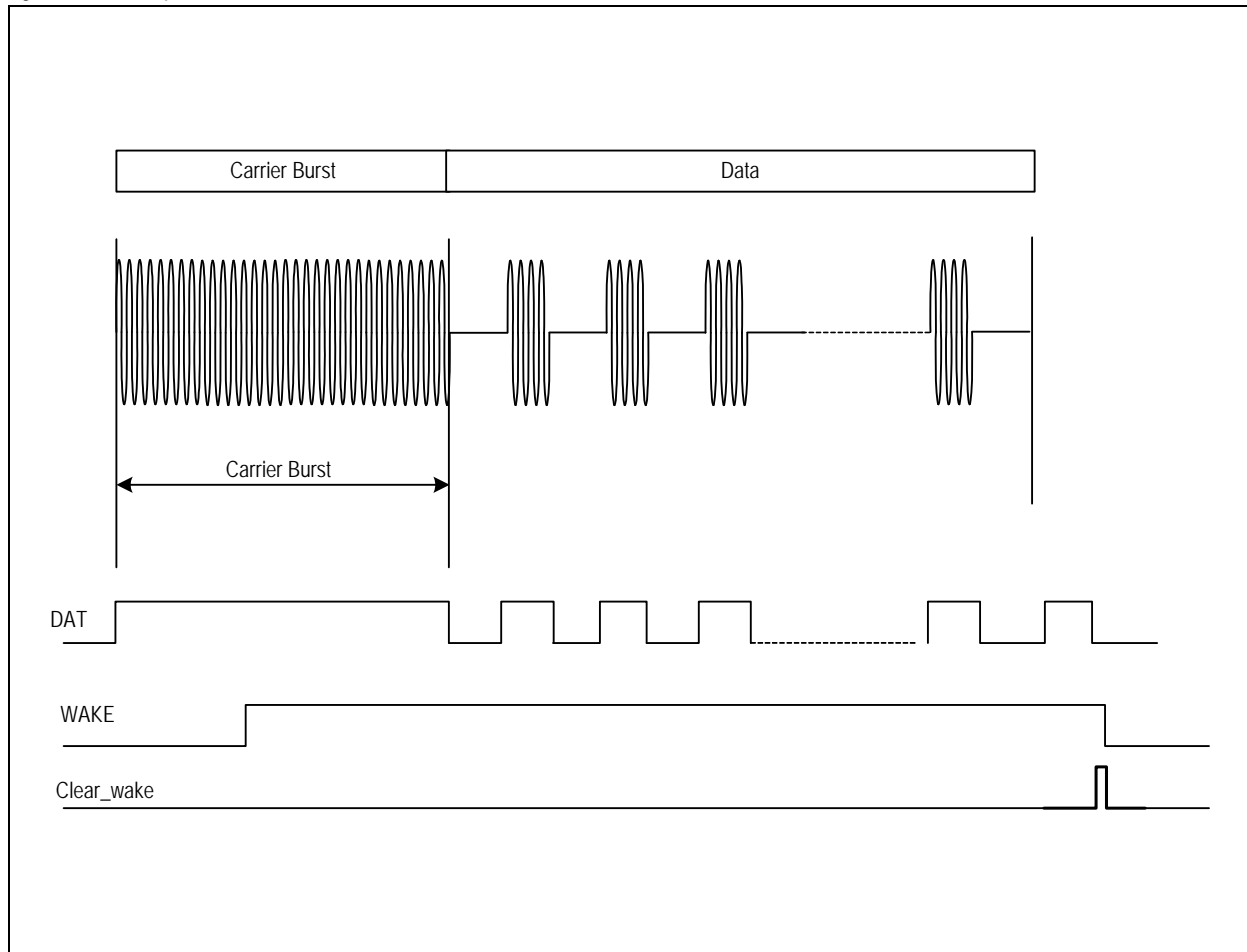

In case the pattern correlation is disabled ( $R1<1>=0$ ) the AS3933 wakes up upon detection of the carrier frequency only as shown in [Figure 24](#). The minimum duration of the carrier burst in order to ensure that AS3933 wakes up and the RSSI is settled is specified in the [Table 24](#). In addition the carrier burst does not have to be longer than 155 periods of the Clock Generator (Crystal oscillator or RCO or External Clock). As shown in the [Figure 11](#), the AS3933 after the detection of the carrier goes directly from the Listening mode to Data receiving mode after settling the RSSI.

### 8.6.2 Wakeup Protocol: Pattern Detection Enabled

In case the pattern correlation is enabled ( $R1<1>=1$ ) the AS3933 generates a wake-up interrupt if the wake-up protocol is fulfilled. The communication protocol consists of a carrier burst, a preamble (0101010... ON/OFF modulated carrier) and the 16-bit pattern. In case the double pattern option is enabled ( $R1<2>=1$ ) the 16-bit pattern has to be repeated 2 times consecutively (2 times the same pattern).

A graphic representation of the wakeup protocol is shown in the [Figure 25](#).

Figure 25. Wakeup Protocol Overview if Pattern Detection is Enabled

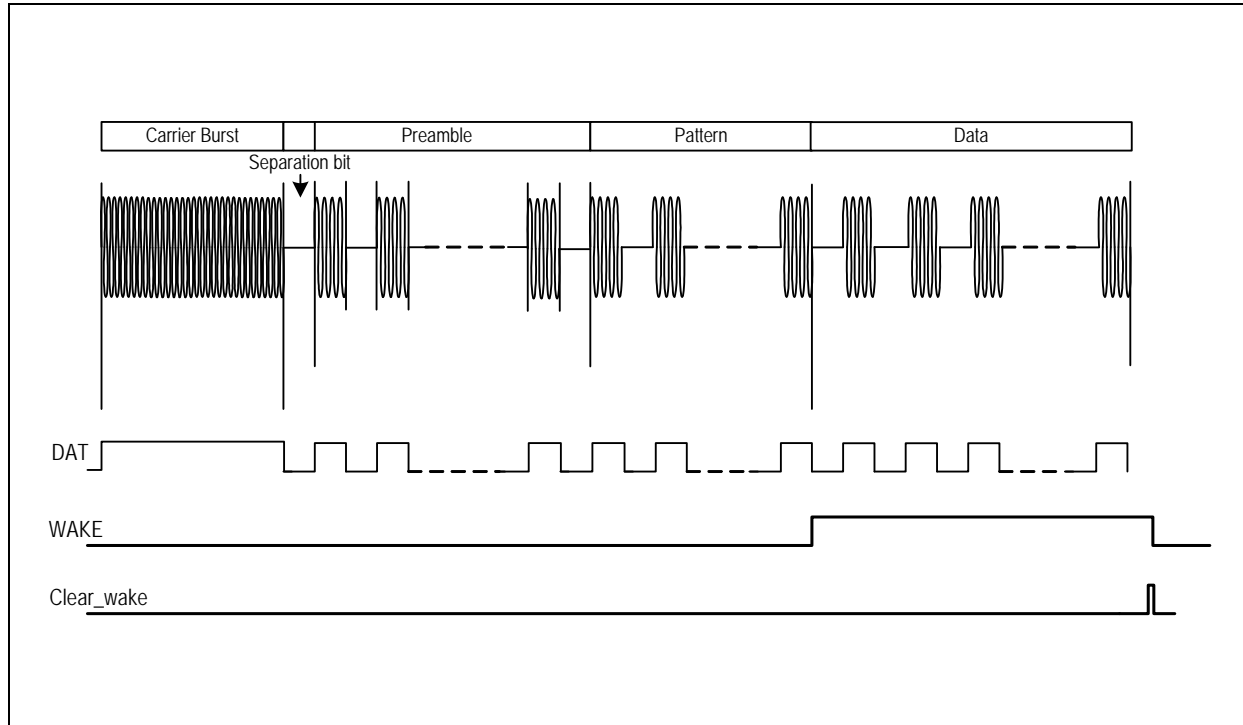

The minimum length for the carrier burst depends on the operating frequency range (see [Table 15](#) bits R8<7:5>) and is described in the [Table 24](#).

Table 24. Minimum Duration of the Carrier Burst

Operating Frequency Range [kHz]	Minimum Duration of the Carrier Burst
95-150	$16 \cdot T_{clk} + 16 T_{carr}$
65-95	$28 \cdot T_{clk} + 16 T_{carr}$
40-65	$52 \cdot T_{clk} + 16 T_{carr}$
23-40	$96 \cdot T_{clk} + 16 T_{carr}$
15-23	$92 \cdot T_{clk} + 8 T_{carr}$

**Notes:**

1.  $T_{clk}$  is the period of the clock generator
2.  $T_{carr}$  is the period of the carrier

If the carrier burst is shorter than what has been specified in the [Table 24](#), then the frequency detection is not guaranteed. In order to fulfill the protocol the carrier burst must be shorter than 155 periods of the clock generator (crystal oscillator or RCO or external clock). The carrier burst must be followed by a separation bit and at least 6 bits preamble (101010). The separation bit must last as half Manchester symbol (see paragraph [8.5.1](#)). The preamble and the pattern cannot be longer than 30 symbols in sum in case 16-bit pattern detection is enabled and 46 symbols if the 32-bit pattern detection is enabled.

In case the ON/OFF option is enabled (R0<5>=1) the minimum duration of the carrier burst must be prolonged by the off time defined in the R4<7:6>.

Should the carrier burst be longer than what is defined in the [Table 24](#) or the number of preamble bits longer than what has been specified above a false wakeup event might be recorded in the register R13<7:0>.

If the Scan Mode be enabled ( $R0<4>=1$ ) the minimum duration of the carrier burst is defined in the [Table 25](#).

Table 25. Minimum Duration of the Carrier Burst in case the Scanning Mode is Enabled

Operating Frequency Range [kHz]	Minimum Duration of the Carrier Burst
95-150	$80 \cdot T_{clk} + 16 T_{carr}$
65-95	$92 \cdot T_{clk} + 16 T_{carr}$
40-65	$180 \cdot T_{clk} + 16 T_{carr}$
23-40	$224 T_{clk} + 16 T_{carr}$
15-23	$220 \cdot T_{clk} + 8 T_{carr}$

### 8.6.3 Manchester Decoder and Clock Recovery

In case the Manchester decoder is enabled ( $R1<3>=1$ ) the AS3933 decodes the incoming Manchester bits automatically and the Manchester decoded data are displayed on the DAT pin and the Manchester recovered clock on the CL\_DAT. The data coming out from the DAT pin are stable (and therefore can be acquired) on the rising edge of the CL\_DAT clock, as shown in [Figure 26](#).

Figure 26. Synchronization of Data with the Manchester Recovered Clock

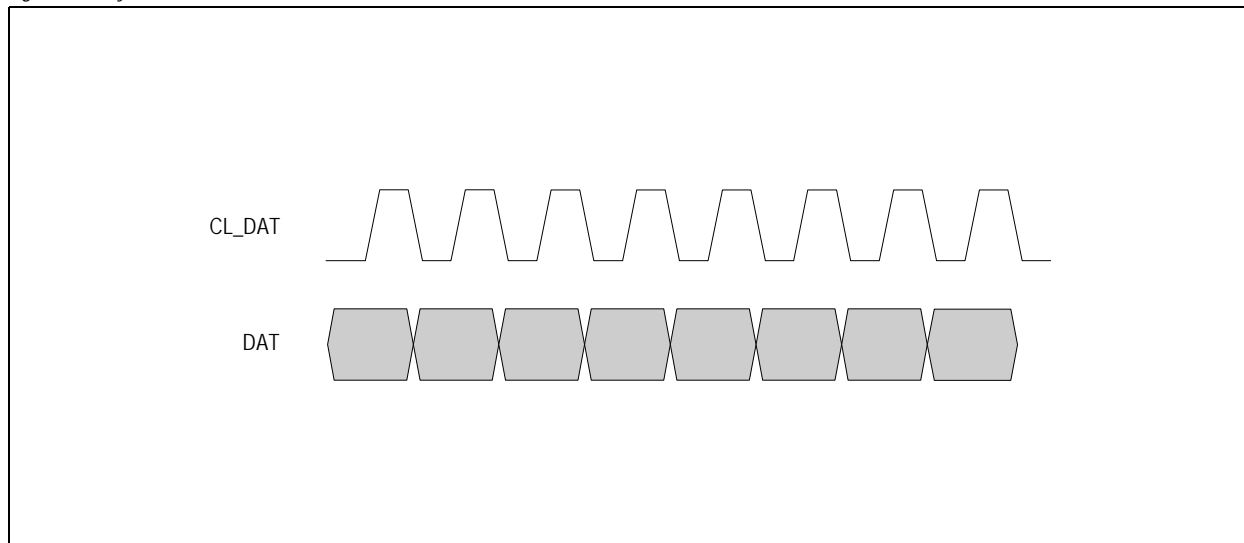

In case a Manchester timing violation happens, the signal on SPO goes high for a duration of 4 periods of internal clock (either crystal oscillator or RCO or external clock).

## 8.7 False Wakeup Register

The wakeup strategy in the AS3933 is based on 2 steps:

1. Frequency Detection: in this phase the frequency of the received signal is checked.
2. Pattern Correlation: here the pattern is demodulated and checked whether it corresponds to the valid one.

If there is a disturber or noise capable to overcome the first step (frequency detection) without producing a valid pattern, then a false wakeup call happens. Each time this event is recognized a counter is incremented by one and the respective counter value is stored in a memory cell (false wakeup register). Thus, the microcontroller can periodically look at the false wakeup register, to get a feeling how noisy the surrounding environment is and can then react accordingly (e.g. reducing the gain of the LNA during frequency detection, set the AS3933 temporarily to power down etc.), as shown in the [Figure 27](#). The false wakeup counter is a useful tool to quickly adapt the system to any changes in the noise environment and thus avoid false wakeup events.

Most wakeup receivers have to deal with environments that can rapidly change. By periodically monitoring the number of false wakeup events it is possible to adapt the system setup to the actual characteristics of the environment and enables a better use of the full flexibility of AS3933.



Figure 27. Concept of the False Wakeup Register Together with the System

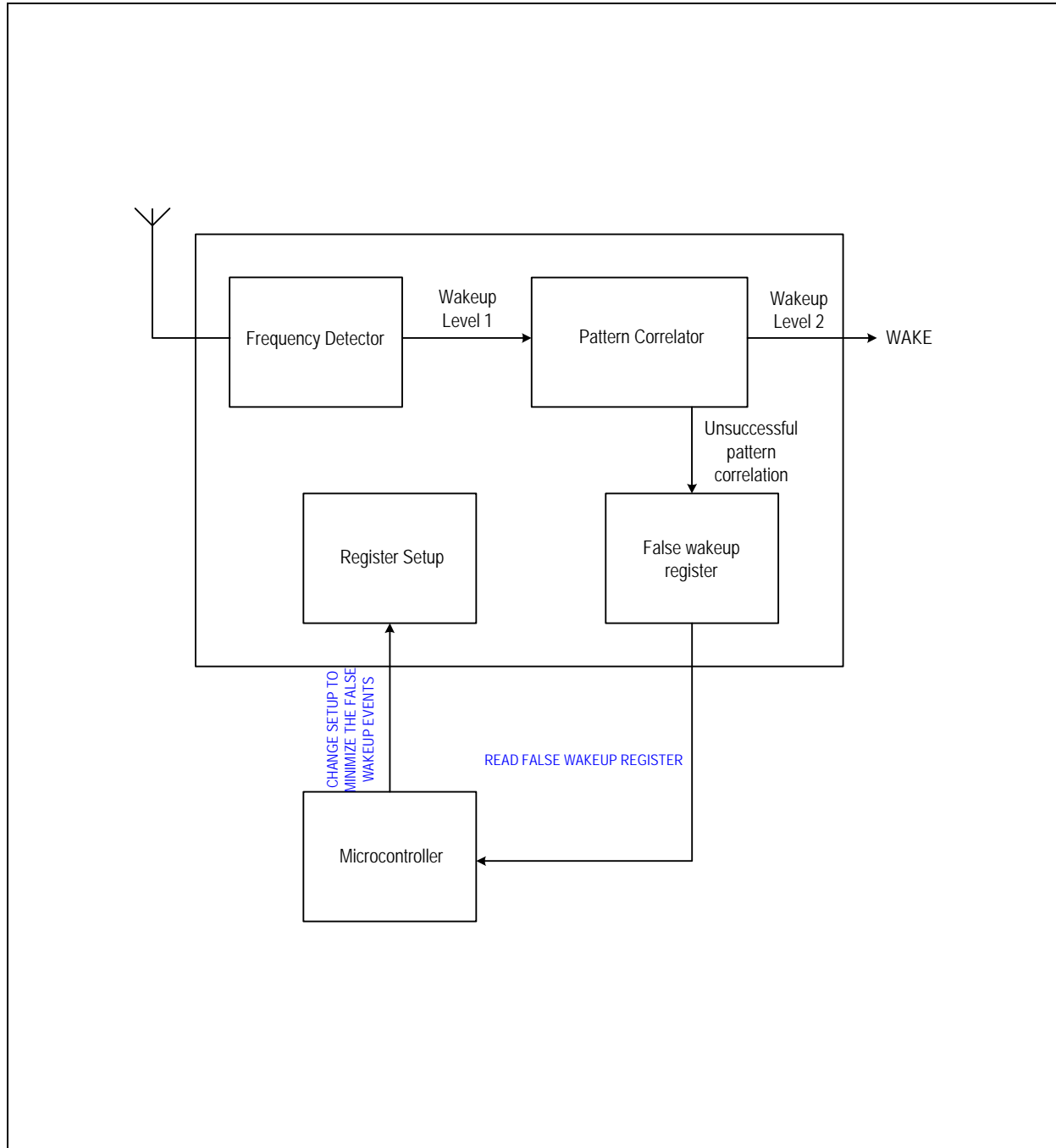

## 8.8 Clock Generator

The Clock Generator can be based on a crystal oscillator (R1<0>=1), the internal RC-oscillator (R1<0>=0), or an external clock source (R1<0>=1). The crystal oscillator has higher precision of the frequency with higher current consumption and needs three external components (crystal plus two capacitors). The RC-oscillator is completely integrated and can be calibrated to increase its precision. Should a digital clock already be available it can be applied directly to the XOUT pin (XIN to VDD).

Regardless which clock generator is chosen, the frequency of the Clock Generator must be set according to the carrier frequency. [Table 26](#) shows the dependency of the Clock Generator frequency from the carrier frequency and operating frequency band.

Table 26. Clock Generator Frequency vs Frequency Band

Carrier Frequency [kHz]	Clock Generator Frequency
15 – 20	$f_{RC} = f_{carr} \cdot \frac{14}{8}$
20 – 40	$f_{RC} = f_{carr} \cdot \frac{9}{8}$
40-65	$f_{RC} = f_{carr} \cdot \frac{5}{8}$
65 – 105	$f_{RC} = f_{carr} \cdot \frac{3}{8}$
105 - 150	$f_{RC} = \frac{f_{carr}}{4}$

It is possible to display the frequency of the clock generator on the CL\_DAT pin writing R2<3:2>=11 and R16<7>=1.

### 8.8.1 Crystal Oscillator

In case the user decides to use the Crystal Oscillator as reference clock a 32.768 kHz quartz can be used in case the tolerance setting for the frequency detection is relaxed (R2<1:0>=00). Should this not be the case, then [Table 26](#) shows how the frequency of the quartz has to be chosen.

If the AS3933 works in the bandwidth 23-40 kHz, then it is recommended not to use the XTAL oscillator to avoid any coupling between the input antennas and the quartz.

Table 27. Characteristics of XTAL

Symbol	Parameter	Conditions	Min	Typ	Max	Units
	Crystal accuracy (initial)	Overall accuracy			±120	p.p.m
	Crystal motional resistance				60	KΩ
	Minimum Frequency	For 32.768 kHz crystal		25		kHz
	Typical Frequency	For 32.768 kHz crystal		32.768		kHz
	Maximum Frequency	For 32.768 kHz crystal		45		kHz
	Contribution of the oscillator to the frequency error			±5		p.p.m
	Start-up Time	Crystal dependent		1		s
	Duty cycle		45	50	55	%
	Current consumption			300		nA

## 8.8.2 RC-Oscillator

Table 28. Characteristics of RCO

Symbol	Parameter	Conditions	Min	Typ	Max	Units
	Calibration time	Periods of reference clock			65	cycles
	Current consumption			650		nA

In case the pattern detection and the Manchester decoder are not enabled ( $R1<1>=0$  and  $R1<3>=1$ ) the calibration on the RC-oscillator is not needed. Should this not be the case, the RC-oscillator has to be calibrated. The calibration of the RC-oscillator can be done in two different ways:

- Over SPI, the host system (MCU) has to be able to provide 65 clock pulses of a reference clock. In this case the host has to have a precise reference clock (quartz, resonator etc.).
- Using the internal calibration procedure based on the antenna resonator. Using this calibration method the RC-oscillator is automatically trimmed to the proper frequency, according to the operating frequency band. The precision of the calibration depends on the tolerances of the resonator of the first channel (LC connected to LF1P).

**RC-Oscillator: Calibration Over SPI.** The calibration gets started with the Calib\_RCosc direct command. Since no non-volatile memory is available on the chip, the calibration must be done every time after battery replacement. Since the Clock Generator defines the time base of the frequency detection, the selected frequency depends on the carrier frequency. The choice of the reference clock frequency delivered by the host (MCU) is the same as the choice of the frequency in case the crystal oscillator is used and it is shown in the Table 26.

To trim the RC-Oscillator, set the chip select (CS) to high before sending the direct command Calib\_RCosc over SPI. Then 65 digital clock cycles of the reference clock (e.g. 32.768 kHz) have to be sent on the clock bus (SCL), as shown in Figure 28. After that the signal on the chip select (CS) has to be pulled down.

The calibration is effective after the 65th reference clock edge and it will be stored in a volatile memory. In case the RC-oscillator is switched off or a power-on-reset happens (e.g. battery change) the calibration has to be repeated.

Figure 28. RC-Oscillator Calibration via SPI

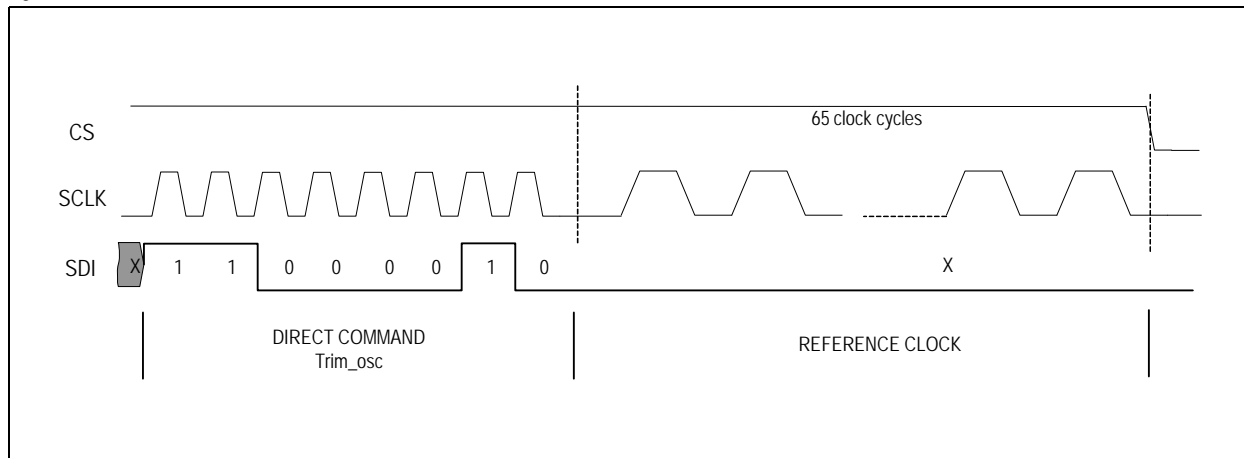

**RC-Oscillator: Self Calibration.** This procedure uses the LC-tank (antenna) connected to the channel 1 (LF1P) not as antenna but as resonator for an oscillator. The internal LC oscillator is therefore connected through a multiplexer to the external tank.

The LC-oscillator generates a clock which corresponds to the resonance frequency of the LC-tank. In a typical application the user designs the external resonators such to set the resonance frequency of the external LC-tank as close as possible to the carrier frequency. The mathematical relation between the oscillation frequency and the LC time constant is:

$$F_{LC} = \frac{1}{2 \cdot \pi \cdot \sqrt{L \cdot C}} \quad (EQ 1)$$

### Where:

L is the inductance and

C the capacitance of the external antenna

To start the calibration the direct command Calib\_RCO\_LC must be sent over the SPI and as soon as the bit  $R14<6>$  is high, the RC-oscillator will be calibrated. The calibrated frequency of the RC-oscillator depends on the carrier frequency and is automatically set to better perform the frequency detection, according to the Table 26.

### 8.8.3 External Clock Source

To clock the AS3933 with an external signal the crystal oscillator has to be enabled ( $R1 < 1 \Rightarrow 1$ ). As shown in the [Figure 3](#) the clock can be directly applied on the pin XOOUT while the pin XIN must be connected to VDD. In the [Table 29](#) the clock characteristics are summarized.

Table 29. Characteristics of External Clock

Symbol	Parameter	Conditions	Min	Typ	Max	Units
Vl	Low level		0		$0.1 * V_{DD}$	V
Vh	High level		$0.9 * V_{DD}$		$V_{DD}$	V
Tr	Rise-time				3	$\mu s$
Tf	Fall-time				3	$\mu s$

**Note:** In power down mode the external clock has to be set to a definite potential (VDD or ground).

The frequency of the external clock source must be set according to the [Table 26](#).

## 8.9 Antenna Tuning

The AS3933 offers the possibility to implement a fine antenna tuning. A block diagram shows how the tuning can be implemented with the help of the host system (MCU).

Figure 29. Tuning Implementation

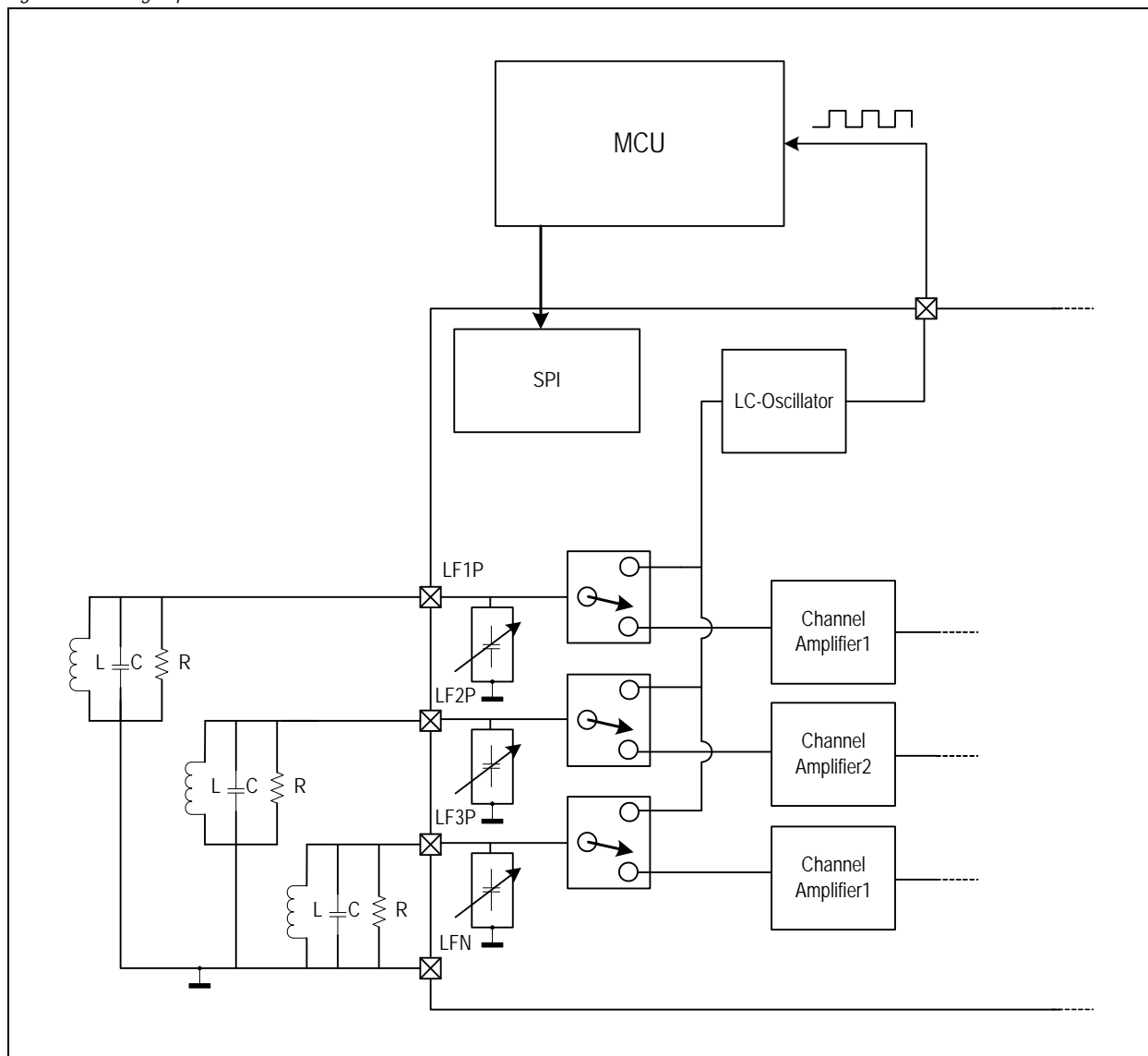

Each of the three antennas can be tuned with the internal capacitor banks. The capacitor can be connected or disconnected (adding or subtracting parallel capacitance to the external resonator) through registers R17<4:0>, R18<4:0> and R19<4:0>.

Table 30. Parallel Tuning Capacitance on the LF1P

R17	Capacitance on LF1P
R17<0>=1	Adds 1pF to LF1P
R17<1>=1	Adds 2pF to LF1P
R17<2>=1	Adds 4pF to LF1P
R17<3>=1	Adds 8pF to LF1P
R17<4>=1	Adds 16pF to LF1P

Table 31. Parallel Tuning Capacitance on the LF2P

R18	Capacitance on LF2P
R18<0>=1	Adds 1pF to LF2P
R18<1>=1	Adds 2pF to LF2P
R18<2>=1	Adds 4pF to LF2P
R18<3>=1	Adds 8pF to LF2P
R18<4>=1	Adds 16pF to LF2P

Table 32. Parallel Tuning Capacitance on the LF3P

R19	Capacitance on LF3P
R19<0>=1	Adds 1pF to LF3P
R19<1>=1	Adds 2pF to LF3P
R19<2>=1	Adds 4pF to LF3P
R19<3>=1	Adds 8pF to LF3P
R19<4>=1	Adds 16pF to LF3P

The Three channels can be tuned separately. The host system (MCU) has to connect the LC-oscillator to the antenna to measure the resonance frequency on the pin CL\_DAT. The host should measure the frequency on this pin and just changing register setting fine tune it to get it as close as possible to the nominal value of the carrier frequency. With the bits R16<2:0> it is possible to connect the LC-oscillator to the three different antennas.

## 8.10 Channel Selection in Scanning Mode and ON/OFF Mode

In case only 2 channels are active and one of the Low Power modes is enabled, then the channels 1 and 3 have to be active. If the chip works in On-Off mode and only one channel is active then the active channel has to be the channel 1.

Both Low Power modes are not allowed to be enabled at the same time.

## 9 Package Drawings and Markings

The devices are available in a 16-pin TSSOP and QFN 4x4 16LD package.

Figure 30. 16-pin TSSOP Package

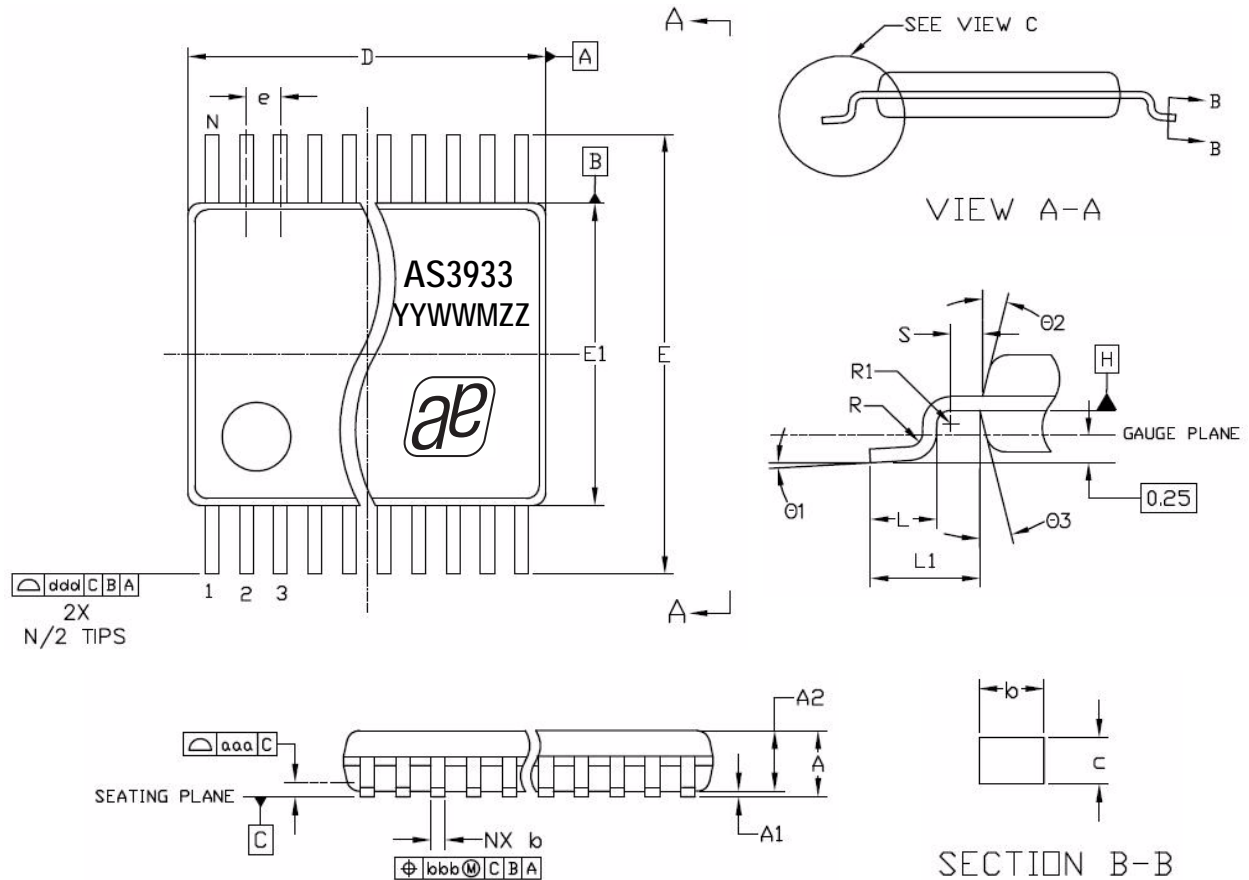

Symbol	Min	Nom	Max
A	-	-	1.20
A1	0.05	-	0.15
A2	0.80	1.00	1.05
b	0.19	-	0.30
c	0.09	-	0.20
D	4.90	5.00	5.10
E	-	6.40 BSC	-
E1	4.30	4.40	4.50
e	-	0.65 BSC	-
L	0.45	0.60	0.75
L1	-	1.00 REF	-

Symbol	Min	Nom	Max
R	0.09	-	-
R1	0.09	-	-
S	0.20	-	-
theta 1	0°		8°
theta 2	-	12 REF	-
theta 3	-	12 REF	-
aaa	-	0.10	-
bbb	-	0.10	-
ccc	-	0.05	-
ddd	-	0.20	-
N		16	



**Notes:**

1. Dimensioning & tolerancing conform to ASME Y14.5M-1994.
2. All dimensions are in millimeters. Angles are in degrees.

Marking: YYWWMMZZ.

YY	WW	M	ZZ
Year (i.e. 10 for 2010)	Manufacturing Week	Assembly plant identifier	Assembly traceability code



## Revision History

Revision	Date	Owner	Description
0.1	31 Mar, 2010	rlc	Initial revision
1.0	01 Jul, 2010		Updated <a href="#">Table 6</a> , <a href="#">Table 8</a> , <a href="#">Table 12</a> , <a href="#">Table 13</a> , <a href="#">Table 27</a> , <a href="#">Table 28</a> , <a href="#">Table 30</a> , <a href="#">Table 31</a> , <a href="#">Table 32</a>
1.1	12 Oct, 2010		Updated <a href="#">Table 6 (Input Sensitivity)</a> , <a href="#">Table 7</a> , <a href="#">Table 8</a>
	03 Nov, 2010		Updated JEDEC standard in Absolute Maximum Ratings.
1.2	12 Nov, 2010		Updated Package Drawings and Markings.
	16 Nov, 2010		Added Marking related information in Package Drawings and Markings and updated footnote in Ordering Information.

**Note:** Typos may not be explicitly mentioned under revision history.



## 10 Ordering Information

The devices are available as the standard products shown in [Table 33](#).

*Table 33. Ordering Information*

Ordering Code	Type	Marking	Delivery Form <sup>1</sup>	Delivery Quantity
AS3933-BTST	16-pin TSSOP	AS3933	7 inches Tape & Reel	1000 pcs
AS3933-BQFT	QFN 4x4 16LD	AS3933	7 inches Tape & Reel	1000 pcs

1. Dry Pack: Moisture Sensitivity Level (MSL) = 3, according to IPC/JEDEC J-STD-033A.

**Note:** All products are RoHS compliant and austriamicrosystems green.  
Buy our products or get free samples online at ICdirect: <http://www.austriamicrosystems.com/ICdirect>

Technical Support is available at <http://www.austriamicrosystems.com/Technical-Support>

For further information and requests, please contact us [mailto: sales@austriamicrosystems.com](mailto:sales@austriamicrosystems.com)  
or find your local distributor at <http://www.austriamicrosystems.com/distributor>

## Copyrights

Copyright © 1997-2010, austriamicrosystems AG, Tobelbaderstrasse 30, 8141 Unterpremstaetten, Austria-Europe. Trademarks Registered ®. All rights reserved. The material herein may not be reproduced, adapted, merged, translated, stored, or used without the prior written consent of the copyright owner.

All products and companies mentioned are trademarks or registered trademarks of their respective companies.

## Disclaimer

Devices sold by austriamicrosystems AG are covered by the warranty and patent indemnification provisions appearing in its Term of Sale. austriamicrosystems AG makes no warranty, express, statutory, implied, or by description regarding the information set forth herein or regarding the freedom of the described devices from patent infringement. austriamicrosystems AG reserves the right to change specifications and prices at any time and without notice. Therefore, prior to designing this product into a system, it is necessary to check with austriamicrosystems AG for current information. This product is intended for use in normal commercial applications. Applications requiring extended temperature range, unusual environmental requirements, or high reliability applications, such as military, medical life-support or life-sustaining equipment are specifically not recommended without additional processing by austriamicrosystems AG for each application. For shipments of less than 100 parts the manufacturing flow might show deviations from the standard production flow, such as test flow or test location.

The information furnished here by austriamicrosystems AG is believed to be correct and accurate. However, austriamicrosystems AG shall not be liable to recipient or any third party for any damages, including but not limited to personal injury, property damage, loss of profits, loss of use, interruption of business or indirect, special, incidental or consequential damages, of any kind, in connection with or arising out of the furnishing, performance or use of the technical data herein. No obligation or liability to recipient or any third party shall arise or flow out of austriamicrosystems AG rendering of technical or other services.



## Contact Information

### Headquarters

austriamicrosystems AG  
Tobelbaderstrasse 30  
A-8141 Unterpremstaetten, Austria

Tel: +43 (0) 3136 500 0  
Fax: +43 (0) 3136 525 01

For Sales Offices, Distributors and Representatives, please visit:

<http://www.austriamicrosystems.com/contact>

# Mouser Electronics

Authorized Distributor

Click to View Pricing, Inventory, Delivery & Lifecycle Information:

[ams:](#)

[AS3933-BTST](#)