

# 2.5mm Pitch Connector for Discrete Wire Connection

## HNC Series

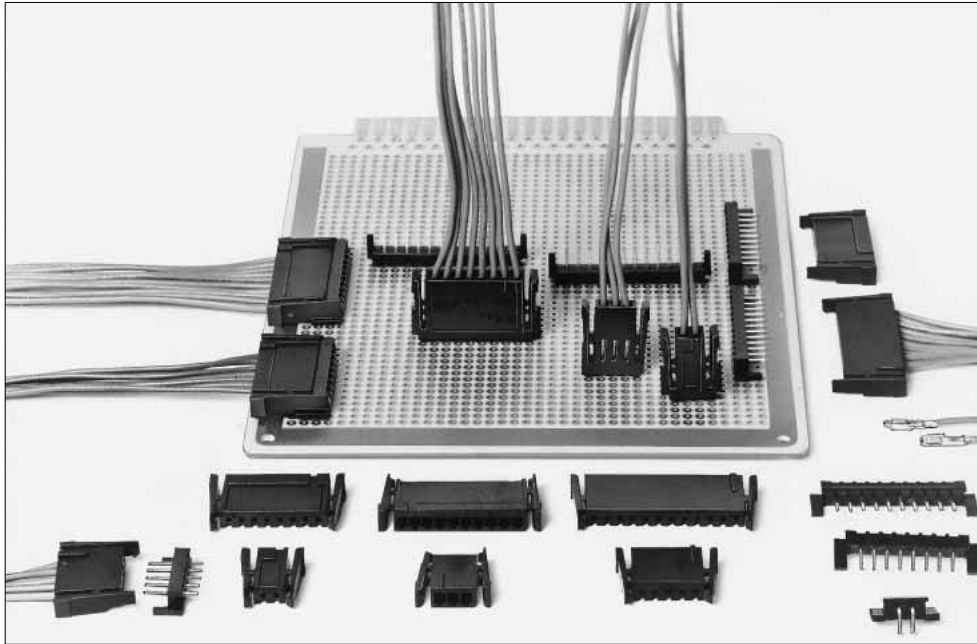

### ■ Features

#### 1. Full Lock Mechanism

The connector is equipped with the full lock mechanism so as not be removed, unless locks are reset on both sides. This mechanism is activated effectively to prevent extraction by cable hooking or other causes.

#### 2. Thin Type Connector

Mounting height when the connector is used at the right angle : **4.8mm**

#### 3. Mechanism to Prevent Mis-insertion

This thin type connector is equipped with the mechanism to prevent mis-insertion.

#### 4. Tin Plating and Gold Plating Variation

Two kinds of tin plating and gold plating types are available, and can be chosen according to application. The tin plating is also set to a light operating touch.

### ■ Applications

Various business equipment, financial terminals

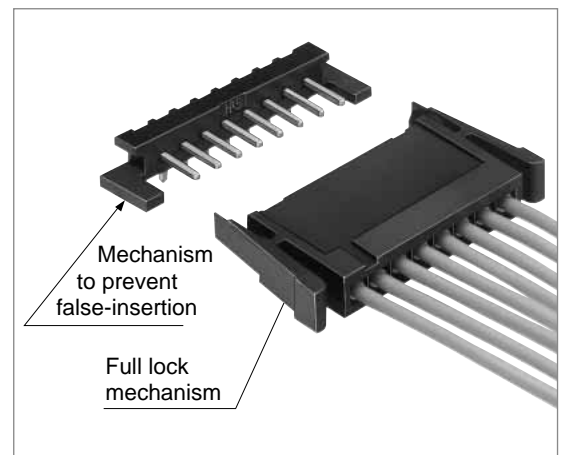

## ■ Product Specifications

Rating	Current rating (Note 1)	22 AWG : 3A 24 AWG : 3A 26 AWG : 2A 28 AWG : 1A 30 AWG : 0.5A	Operating Temperature Range Operating Humidity Range	-55 to +85°C (Note 2) 20 to 80%
	Voltage rating	250V AC	Storage Temperature Range Storage Humidity Range	-10 to +60°C (Note 3) 40 to 70% (Note 3)

Item	Specification	Condition
1. Insulation Resistance	1000MΩ min.	500V DC
2. Withstanding voltage	No flashover or insulation breakdown.	1000V AC/1 minute
3. Contact Resistance	10mΩ Max	Measured at a maximum of 20V, 1mA (DC or 1000Hz)
4. Insertion/Extraction Force	Insertion force : 4.4N max. Extraction force : 0.4N min.	Measure at the square steel pin of 0.635±0.002mm
5. Vibration	No electrical discontinuity of 10μs or more	10 cycles in each of three axis at frequency 10-55Hz, half amplitude 0.75mm
6. Humidity (Steady state)	Contact resistance : 10mΩ max. Insulation resistance : 1000MΩ min.	96 hours at temperature of 40±2°C and humidity of 90% to 95%
7. Temperature Cycle	Contact resistance : 10mΩ max. Insulation resistance : 1000MΩ min.	(-55°C : 30 minutes → 5 to 35°C : 2 to 3 minutes 85°C : 30 minutes → 5 to 35°C : 2 to 3 minutes) 5 cycles
8. Durability (Mating/un-mating)	Tin plating : Contact resistance : 30mΩ max. Gold plating : Contact resistance : 20mΩ max.	Tin plating : 30 cycles Gold plating : 50 cycles
9. Resistance to Soldering heat	No deformation of components affecting performance.	Flow : 250°C for 5 seconds
		Manual soldering : 300°C for 2 seconds

Note 1 : The rated current will be changed according to cable sizes for use. The header rating only it is 3A.

Note 2 : Includes temperature rise caused by current flow.

Note 3 : The term "storage" refers to products stored for long period of time prior to mounting and use. Operating Temperature Range and Humidity range covers non conducting condition of installed connectors in storage, shipment or during transportation.

Note 4 : Information contained in this catalog represents general requirements for this Series. Contact us for the drawings and specifications for a specific part number shown.

## ■ Materials / Finish

Product	Part	Material	Finish	Remarks
Crimping Socket	Insulator	Polyamide	Black	UL94V-2
Contact	Contact	Phosphor Bronze	Tin plated or gold plated	—
Pin Header	Insulator	Polyamide	Black	UL94V-2
	Contact	Brass	Tin plated or gold plated	—

## ■ Product Number Structure

Refer to the chart below when determining the product specifications from the product number.  
Please select from the product numbers listed in this catalog when placing orders.

### ● Crimping Plug

HNC   2   -   2.5   P   -   \*   DSL  
 ①   ②   ③   ④   ⑤   ⑥

① Series Name : HNC	⑤ Number of Contacts : 2 to 8,10,12,15
② Series No. : 2, 1	⑥ Contact Type None : Crimping socket DS : Straight DSL : Right angle
③ Contact Pitch : 2.5mm	
④ Connector Type S : Socket P : Pin Header	

### ● Contact

**HNC**   -   2.5S   -   C   -   A  
 ①   ②   ③

① Type: 2.5mm pitch socket	③ Applicable cable size A : 22 to 26 AWG B : 26 to 30 AWG
② Packaging Type C : Reel D : Bag	

■ Crimping Socket



[Fig.1]

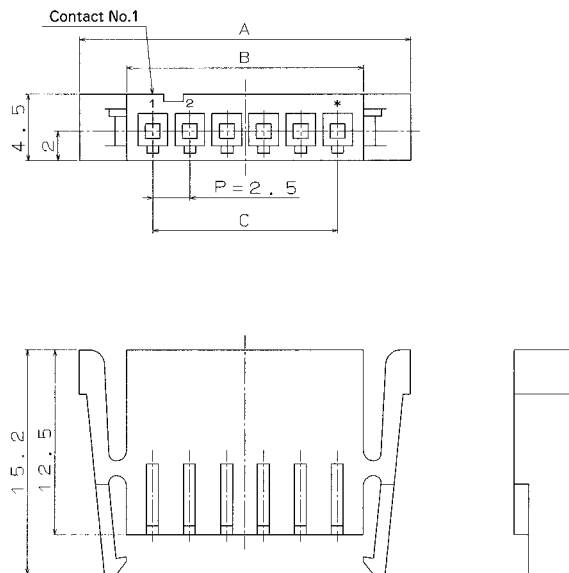

[Fig.2]

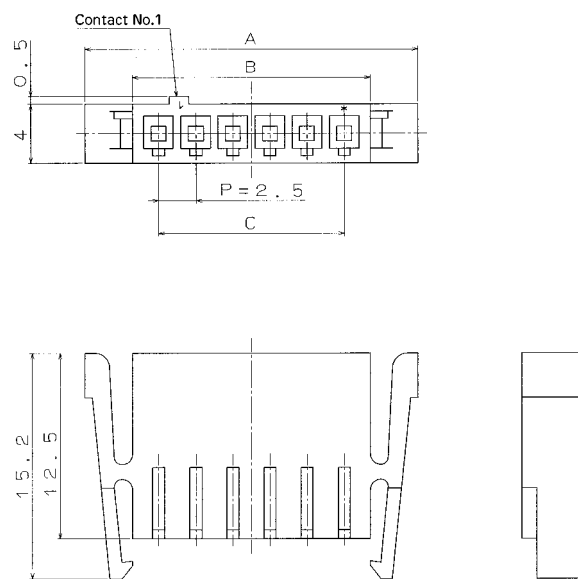

Unit : mm

Part No.	HRS No.	No. of Contacts	A	B	C	Dimensions	RoHS
HNC2-2.5S- 2	218-0011-1	2	12.4	6.0	2.5	Fig.1	Yes
HNC2-2.5S- 3	218-0022-8	3	14.9	8.5	5.0		
HNC2-2.5S- 4	218-0039-0	4	17.4	11.0	7.5		
HNC2-2.5S- 5	218-0027-1	5	19.9	13.5	10.0		
HNC2-2.5S- 6	218-0042-5	6	22.4	16.0	12.5		
HNC2-2.5S- 7	218-0030-6	7	24.9	18.5	15.0		
HNC2-2.5S- 8	218-0014-0	8	27.4	21.0	17.5		
HNC2-2.5S-10	218-0017-8	10	32.4	26.0	22.5		
HNC1-2.5S-12	218-0008-7	12	37.0	31.0	27.5	Fig.2	
HNC2-2.5S-15	218-0045-3	15	44.9	38.5	35.0	Fig.1	

Note1 : Please order a quantity multiplied by 100 pcs. (Not per bag, but per pcs.)

Note2 : The series name of 12 contacts connector is HNC1, and partially will be changed in the style.

## ■ Straight Pin Header

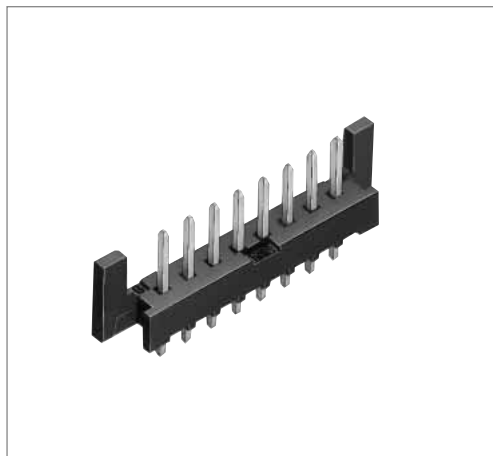

●Board Through-hole Diameter:  $\phi 1.1^{+0.1}$

[Fig.3]

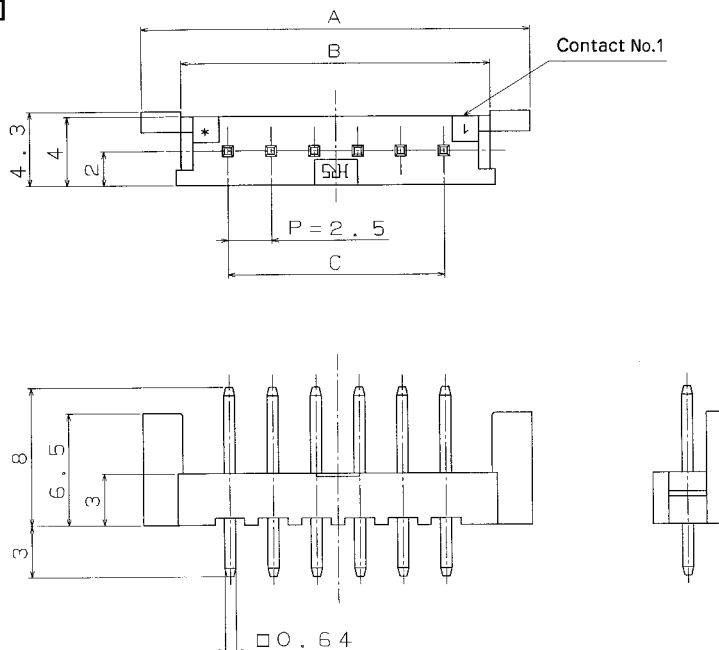

[Fig.4]

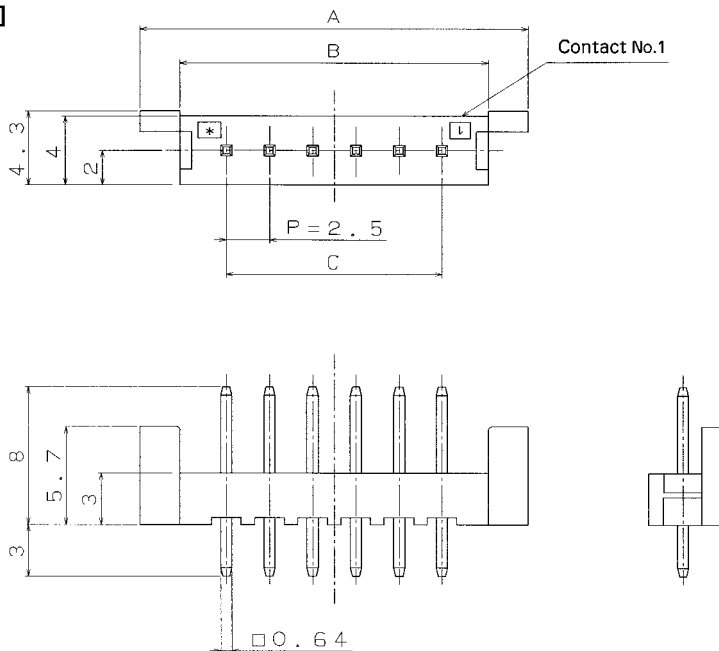

Unit : mm

Part No.	HRS No.	No. of Contacts	A	B	C	Specific No.		Dimensions	RoHS
						Tin plating	Gold plating		
HNC2-2.5P- 2DS(**)	218-0012-4-**	2	12.5	7.8	2.5	55	02	Fig.3	Yes
HNC2-2.5P- 3DS(**)	218-0023-0-**	3	15.0	10.4	5.0	55	02		
HNC2-2.5P- 4DS(**)	218-0040-0-**	4	17.5	12.9	7.5	55	01		
HNC2-2.5P- 5DS(**)	218-0028-4-**	5	20.0	15.4	10.0	55	02		
HNC2-2.5P- 6DS(**)	218-0043-8-**	6	22.5	17.9	12.5	55	01		
HNC2-2.5P- 7DS(**)	218-0031-9-**	7	25.0	20.4	15.0	55	02		
HNC2-2.5P- 8DS(**)	218-0015-2-**	8	27.5	22.8	17.5	55	02		
HNC2-2.5P-10DS(**)	218-0018-0-**	10	32.5	27.8	22.5	55	02	Fig.4	
HNC1-2.5P-12DS(**)	218-0009-0-**	12	35.5	32.8	27.5	55	02		
HNC2-2.5P-15DS(**)	218-0046-6-**	15	45.0	40.4	35.0	55	01	Fig.3	

Note1 : Please order a quantity multiplied by 100 pcs. (Not per bag, but per piece)

Note2 : The series name of the 12 contacts connector is HNC1 and the style will be partially changed.

■ Right Angle Pin Header [Fig.5]

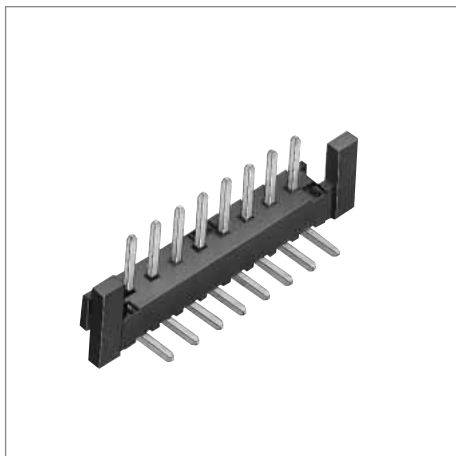

● Board Through-hole Diameter:  $\phi 1.1^{+0.1}$

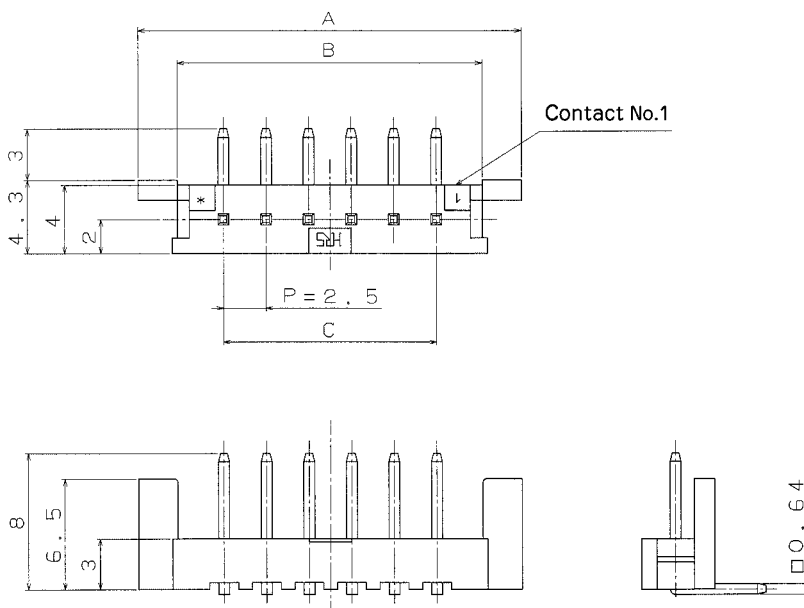

[Fig.6]

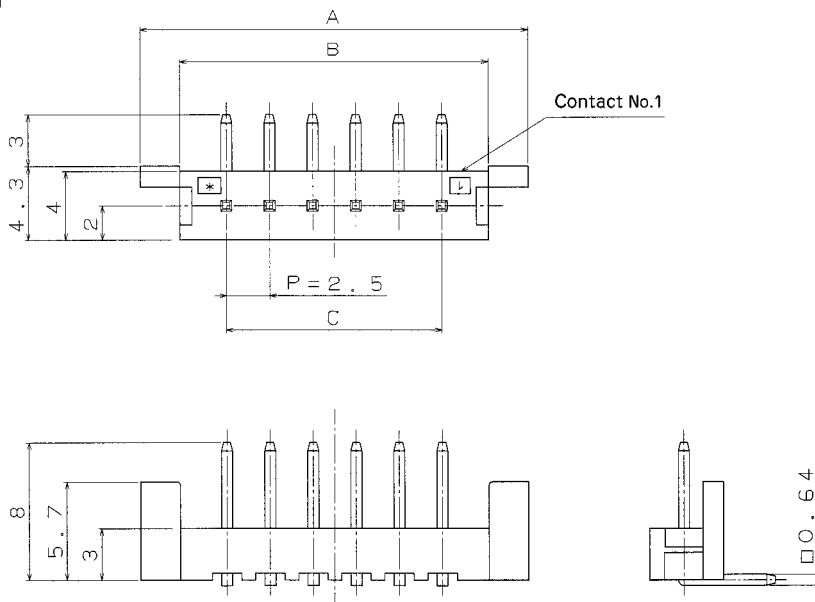

Unit : mm

Part No.	HRS No.	No. of Contacts	A	B	C	Specific No.		Dimensions	RoHS
						Tin plating	Gold plating		
HNC2-2.5P- 2DSL(**)	218-0013-7-**	2	12.5	7.8	2.5	55	02	Fig.5	Yes
HNC2-2.5P- 3DSL(**)	218-0024-3-**	3	15.0	10.4	5.0	55	02		
HNC2-2.5P- 4DSL(**)	218-0041-2-**	4	17.5	12.9	7.5	55	01		
HNC2-2.5P- 5DSL(**)	218-0029-7-**	5	20.0	15.4	10.0	55	02		
HNC2-2.5P- 6DSL(**)	218-0044-0-**	6	22.5	17.9	12.5	55	01		
HNC2-2.5P- 7DSL(**)	218-0032-1-**	7	25.0	20.4	15.0	55	02		
HNC2-2.5P- 8DSL(**)	218-0016-5-**	8	27.5	22.8	17.5	55	02		
HNC2-2.5P-10DSL(**)	218-0019-3-**	10	32.5	27.8	22.5	55	02	Fig.6	Yes
HNC1-2.5P-12DSL(**)	218-0010-9-**	12	35.5	32.8	27.5	55	02		
HNC2-2.5P-15DSL(**)	218-0047-9-**	15	45.0	40.4	35.0	55	01	Fig.5	

Note1 : Please order a quantity multiplied by 100 pcs. (Not per bag, but per piece)

Note2 : The series name of the 12 contacts connector is HNC1 and the style will be partially changed.

## ■ Crimping Contact for Socket

### ● Applicable Cable (Tin Plated Annealing Copper Wire)

### ● Recommended Cable

UL1061, UL1007

### ● Strip Length

2.8 to 3.3mm

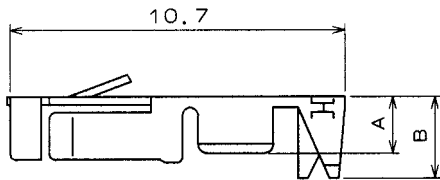

Conductor Size (Contact wire construction)	Jacket Diameter
22 AWG (17pieces/0.16mm)	φ1.35 to φ1.7mm
24 AWG (11pieces/0.16mm)	
26 AWG (7pieces/0.16mm)	
28 AWG (7pieces/0.127mm)	φ1.0 to φ1.35mm
30 AWG (7pieces/0.1mm)	

Note: If other cables are used instead of the applicable cable, please contact Hirose sales department.

Unit : mm

Part No.	HRS No.	Conductor Size	Jacket Diameter	A	B	Packaging Type	Quantity	Specific No.		RoHS
								Tin plating	Gold plating	
HNC-2.5S-D-A(**)	218-0037-5-**-	22 to 26 AWG	φ1.35 to 1.7mm	1.8	2.6	Bag	100	15	02	Yes
HNC-2.5S-C-A(**)	218-0021-5-**-			1.8	2.6	Reel	10,000			
HNC-2.5S-D-B(**)	218-0038-8-**-	26 to 30 AWG	φ1.0 to 1.35mm	1.5	1.7	Bag	100			
HNC-2.5S-C-B(**)	218-0020-2-**-			1.5	1.7	Reel	10,000			

## ◆ Applicable Crimping Tool

Type	Part No.	HRS No.	Applicable Contact
Applicator	AP105-HNC	901-4502-0	HNC-2.5S-C-A(**)/HNC-2.5S-C-B(**)
Press Main Unit	CM-105C	901-0001-0	
Manual Crimping Tool	TC-HNC-B	250-0005-7	HNC-2.5S-D-B(**)
	TC-HNC-A	250-0006-0	HNC-2.5S-D-A(**)
Extraction Tool	Flat-blade screwdriver (thickness < 0.75mm)		

Note 1 : If a trouble has occurred due to tools which are not designated by Hirose, Hirose won't guarantee any product.

Note 2 : Please do the crimping operations according to the "Crimp quality standard" and "Crimping condition table".

## ◆ Application Pattern

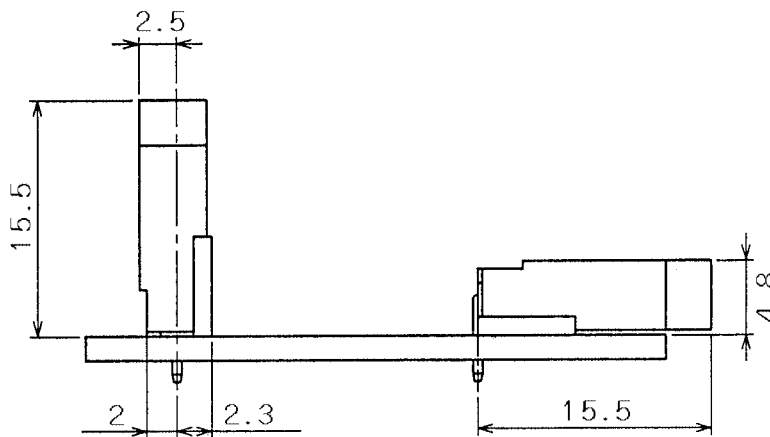

## ◆ Precautions

1. Recommended Soldering Condition	Flow : 250°C for 5 seconds Manual soldering : 300°C for 2 seconds
2. Cleaning Condition	Refer to Wire-to-Board Connector Use Handbook.
3. Connection Condition	Refer to Wire-to-Board Connector Use Handbook.