

SYMBOL DEFINITION		MISSING NUMBERS		DWO STATUS				REVISION HISTORY				AUTH		DR		APVD				
A DIMENSION WITHOUT AN INSPECTION REPORT SYMBOL DOES NOT REQUIRE INSPECTION. IT MAY BE CONTROLLED ON AN INDIVIDUAL COMPONENT DRAWING.		TOTAL NO. OF SYMBOLS ON DRAWING	17	57,				DATE	STG	REV	N/P	CHG	ZONE							
		LAST NO. USED	71					08DE00	R	001	-	-	15404336	-	RELEASED	000005	EOV	EOV	JR	JR
						08DE00	R	002	-	-	-	-	12034398 & 12193537	-	WERE SEPARATE DRAWINGS	204920	EOV	EOV	JR	JR
						14JN04	R	03	-	-	-	-	12193537 & 15404336	-	OBSOLETE AND ADDED NOTE 8	253207	ESH	JVM	SAN	SAN
						25MY04	R	04	-	-	-	-	15492542 & 12034398	-	RELEASED; RESTRICTED	255769	6PS	FRG	MGR	MGR
						26AP05	R	05	-	-	-	-	12034398 & 15492542	-	REMOVED LABEL FOR ASSEMBLY PART NUMBER CALLOUT	266520	JTV	FKV	MGR	MGR
						03NO05	R	06	-	-	-	-	12034398	-	OBSOLETE	273752	CCV	JVM	MGR	MGR

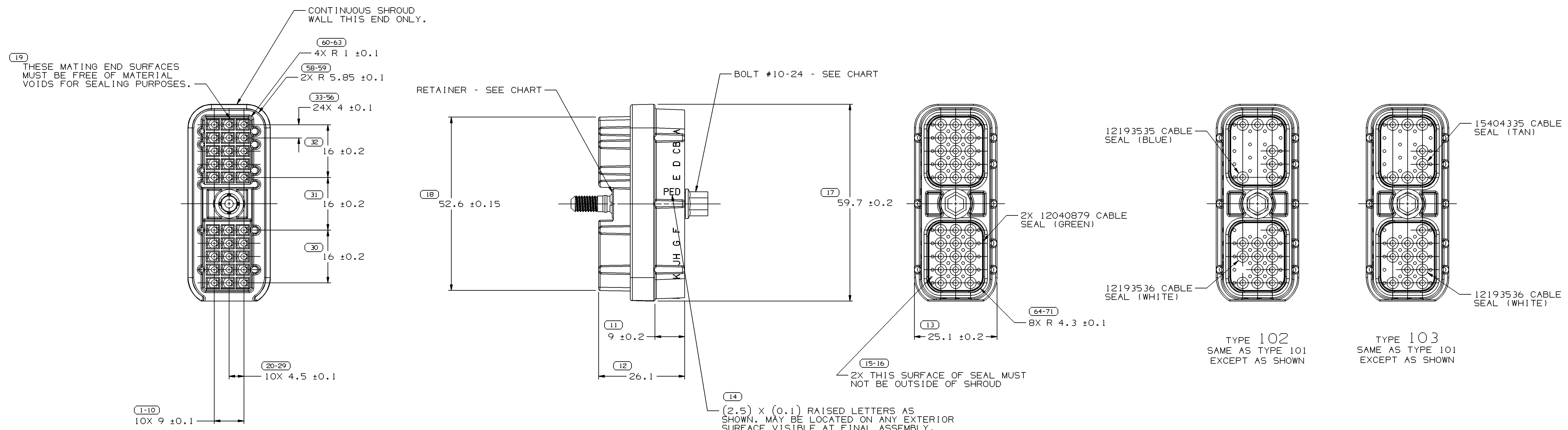

NOTES

- UNLESS OTHERWISE SPECIFIED AND/OR INDICATED: DIMENSIONS ARE TO FACE OF VIEW SHOWN AND AUTOMATICALLY ROUNDED BY COMPUTER FOR INSPECTION (SEE MATH MODEL FOR PRECISE DIMENSIONS). FOR ALL OTHER DIMENSIONS NOT SHOWN BUT REQUIRED FOR TOOL BUILD, SEE MATH MODEL FOR PRECISE TOOL PATH DATA.
- SEALING CODE 3 - DESIGN WILL PASS SALT FOG AND IMMERSION TEST AFTER CONDITIONING AS SPECIFIED IN ESA-644 (WEATHER-PACK), ESA-710 (METRI-PACK), ESA-650 (UNDERHOOD MICRO-PACK), C-4006 (WORLD CONNECTOR), ETC WHEN MATED TO MATING PART OR EQUIVALENT
- THIS PART IS NOT CONTROLLED FOR AUTOMATIC FEEDING.
- REFERENCE MATING COMPONENTS OR EQUIVALENT: CONNECTOR 12034395 TERMINAL 12047680
- BOLT TO BE RETAINED IN ASSEMBLY TO A MINIMUM 400 N.
- RECOMMENDED MATING TORQUE: 0.8 N-M TO 1.5 N-M.
- BOLT MUST ROTATE IN CONNECTOR AT A TORQUE OF LESS THAN 0.6 N-M (5.3 INCH-POUNDS) AFTER RETAINER IS ASSEMBLED.
- OBSOLETE PART(S) CONTAINS A HEXAVALENT CHROME COATING. DO NOT USE THIS PART ON NEW APPLICATIONS. HEXAVALENT CHROME IS A BANNED SUBSTANCE. IF THIS PART IS REQUIRED FOR CURRENT OR FUTURE BUSINESS OR FOR SERVICE REQUIREMENTS, CONTACT THE PRODUCT LINE ENGINEER OR MATERIALS ENGINEERING TO GET A NEW PART THAT IS FREE FROM HEXAVALENT CHROME. EXISTING INVENTORY OF THIS PART MAY BE USED UNTIL JULY 1, 2007 FOR SERVICE REQUIREMENTS.

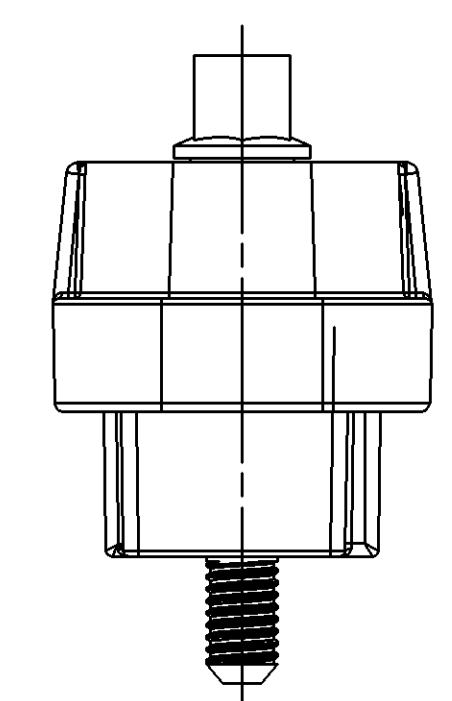
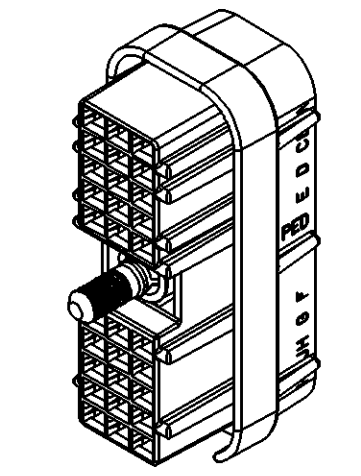

PART NO	REV	N/P	STATUS	TYPE	CONNECTOR BODY	BOLT	RETAINER	COLOR
15492542	01	AA	-	101	12034397	15492534	15492535	BLACK
15404336	01	AA	OBSOLETE	103	12034397	12034235	12034236	BLACK
12193537	A4	-	OBSOLETE	102	12034397	12034235	12034236	BLACK
12034398	C6	-	OBSOLETE	101	12034397	12034235	12034236	BLACK

DIMENSIONAL RANGE (MM)	CHART ET
FROM > 0	> 70
TO > 20	> 100
> 30	> 150
> 40	> 200
> 50	> 250
> 60	> 300
> 70	> 400

DWO TYPE: PART DRAWING

STYLE: D

VOLUME (CM³):

DISTR CODE: D

UNLESS OTHERWISE SPECIFIED THIS DOCUMENT IS IN ACCORDANCE WITH ASME Y14.5M-1994 AS AMENDED BY THE 2003 DIMENSIONING AND TOLERANCING ADDENDUM (2003). SEPARATE PATTERNING OF FEATURES MAY BE OBTAINED SEPARATELY REGARDLESS OF DATUM REFERENCES.

ALL DIMENSIONS ARE IN MILLIMETERS

REFERENCE:

(N/A) PROCESS SENSITIVE DIMENSION DIMENSIONS ENCLOSED IN () INDICATE REFERENCE DIMENSIONS AND NO TOLERANCE LIMITS ARE ESTABLISHED

THIRD ANGLE PROJECTION

DO NOT SCALE

USE MATH DATA

DELPHI

DELPHI PACKARD ELECTRIC SYSTEMS
WARREN, OH

DR	DATE
APVD1 E. VAZQUEZ	08DE00
APVD2 E. VAZQUEZ	08DE00
APVD3 J. REIDER	08DE00
APVD4	
APVD5	

SUBSTANCES OF CONCERN AND RECYCLED CONTENT PER DELPHI 10949001

MATERIAL SEC. DRG

DRAWING NAME: TAXI ASM CONN 30 F M/P 150 SLD

DRAWING NUMBER: 15404892

SIZE: A0 SCALE: 2:1 FRAME NO: 1 OF 1 SHEET NO: 1 OF 1 DATE: 06

Mouser Electronics

Authorized Distributor

Click to View Pricing, Inventory, Delivery & Lifecycle Information:

[Aptiv:](#)

[15492542-B](#) [15492542](#)