



Slide Locks F-GV-...

Gleitverriegelung F-GV-...

Dimensions

Abmessungen

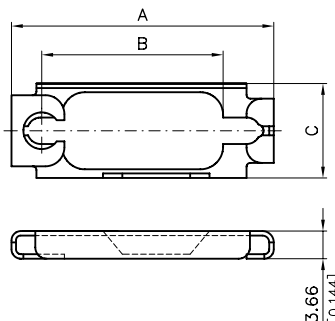

Order Number <i>Bestellnummer</i>		Shell Size <i>Gehäusegröße</i>	A	B	C
Appliance Assembly <i>Gerätemontage</i>	Hood Assembly <i>Haubenmontage</i>				
F-GV-1	F-GV-1H	1	34,7 (1.366)	25,0 (0.984)	12,5 (0.492)
F-GV-2	F-GV-2H	2	43,0 (1.693)	33,3 (1.311)	12,5 (0.492)
F-GV-3	F-GV-3H	3	56,8 (2.236)	47,04 (1.852)	12,5 (0.492)
F-GV-4	F-GV-4H	4	73,2 (2.882)	63,5 (2.500)	12,5 (0.492)
F-GV-5	F-GV-5H	5	71,8 (2.827)	61,1 (2.406)	14,7 (0.579)

Packing Unit <i>Verpackungseinheit</i>	
Appliance Assembly <i>Gerätemontage</i>	Hood assembly <i>Haubenmontage</i>
1 frame <i>1 St. Rahmen</i>	1 frame <i>1 St. Rahmen</i>
2 short screws <i>2 St. kurze Schrauben</i>	2 long screws <i>2 St. lange Schrauben</i>
2 nuts <i>2 St. Muttern</i>	—
2 spring washers <i>2 St. Federringe</i>	—

Ordering Example

Bestellbeispiel

Slide lock for hood mounting, shell size 2:

F-GV-2H

Slide lock for hood mounting, shell size 2 for lock post with M3:

F-GV-3HM3

Gleitverriegelung für Haubenmontage bei Gehäusegröße 2:

F-GV-2H

Gleitverriegelung für Haubenmontage bei Gehäusegröße 3 für Gegenschraube mit M3:

F-GV-3HM3

Lock Posts F-SGV1/5-... for Slide Locking

Gegenschraube F-SGV1/5-... für Gleitverriegelung

Outer Thread 4-40 UNC

Außengewinde 4-40 UNC

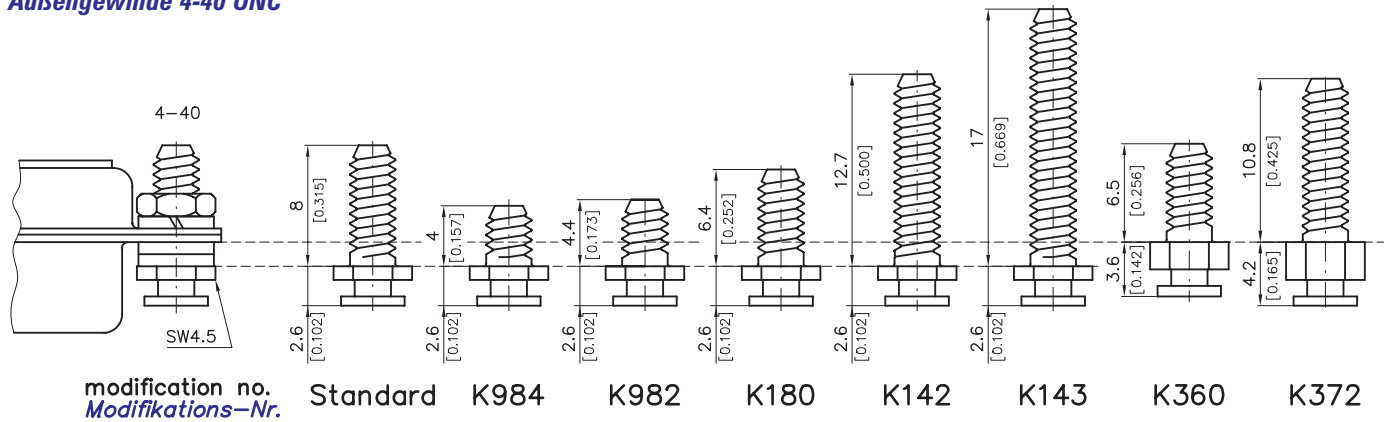

Outer Thread M3

Außengewinde M3

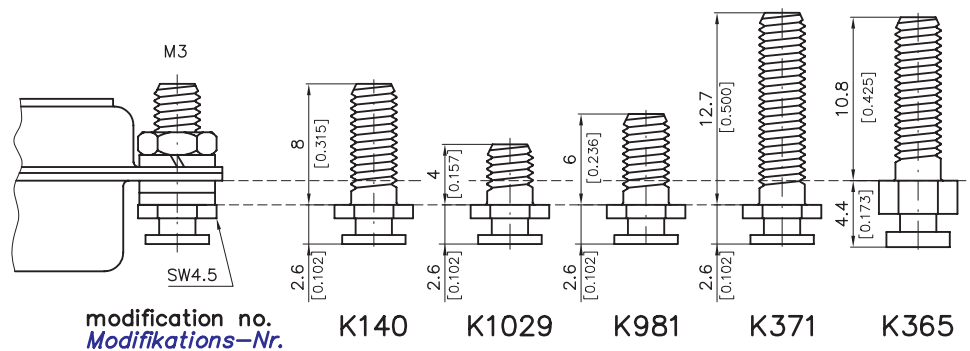

Specification

Technische Beschreibung

	Zinc Plated Version <i>Verzinkte Ausführung</i>	Tin Plated Version <i>Verzinnte Ausführung</i>
Order Number <i>Bestellnummer</i>	F-SGV1/5-...	F-SGV1/5-...SN
Material <i>Material</i>	steel, zinc plated, yellow chromate <i>Stahl verzinkt, gelb chromatiert</i>	steel, tin plated <i>Stahl verzinkt</i>

Packing Unit <i>Verpackungseinheit</i>	
Head Height 0.012" <i>Kopfhöhe 2,6 mm</i>	Head Height 0.165" <i>Kopfhöhe 4,2 mm</i>
2 bolts <i>2 St. Bolzen</i>	2 bolts <i>2 St. Bolzen</i>
4 washers <i>4 St. Unterlegscheiben</i>	—
2 spring washers <i>2 St. Federringe</i>	2 spring washers <i>2 St. Federringe</i>
2 nuts <i>2 St. Muttern</i>	2 nuts <i>2 St. Muttern</i>

Ordering Example

Bestellbeispiel

Lock post for slide lock, Hex. 4.5 mm (0.177"), head size 2.6 mm (0.102"), outer thread M3, length 8 mm (0.197"), tin plated:

Gegenschraube für Gleitverriegelung mit Schlüsselweite 4,5 mm, Kopfhöhe 2,6 mm, Außengewinde M3, Länge 8 mm, verzinkt:

F-SGV1/5-K140SN

F-SGV1/5-K140SN

Mouser Electronics

Authorized Distributor

Click to View Pricing, Inventory, Delivery & Lifecycle Information:

[Molex:](#)

[FSGK1/5](#) [F-SGV1/5](#) [F-SGV1/5-K372SN](#) [F-SGV1/5-K365](#) [F-SGV1/5-K373SN](#) [F-SGV-1/5-K140](#)