

22.5 mm RU2R4 Part number 88866300



- Relay output
- Multi-function or mono-function
- Multi-range
- Multi-voltage
- Screw terminals
- LED status indicator

Part numbers

	Type	Functions	Timing	Output	Nominal rating	Connections	Supply voltage
88 866 300	RU2R4	A - Ac - At - B - Bw - C - D - Di - H - Ht	0,1s →100h	2 changeover relay	2 x 8 A	Screw terminals	12 V AC/DC

Specifications

Timing

Timing ranges (7 ranges)	1 s - 10 s - 1 min - 10 min - 1 h - 10 h - 100 h
Repetition accuracy with constant parameters	± 0.5 % (IEC/EN 61812-1)
Drift Temperature	± 0,05 % / °C
Drift Voltage	± 0,2 % / V
Display accuracy according to IEC/EN 61812-1	± 10 % / 25 °C
Immunity from micro power cuts : typical	< 10 ms

Supply

Multi-voltage power supply	Depending on version
Frequency (Hz)	50 / 60
Operating factor	100 %

Output specification

Rated power	2000 VA/80 W
Maximum breaking current	8 AAC 250 VAC resistive 8 ADC 30 VDC resistive
Minimum breaking current	10 mA / 5 VDC
Voltage breaking capacity	250 VAC / 8 AAC resistive 250 VDC / 0,3 A resistive
Electrical life (operations)	10 ⁵ 8 A 250 VAC resistive
Mechanical life (operations)	10 x 10 ⁶
Breakdown voltage acc. to IEC/EN 61812-1	2,5 kV / 1 min / 1 mA / 50 Hz
Impulse voltage acc. to IEC/EN 60664-1, IEC/EN 61812-1	5 kV wave 1.2 / 50 µs

General characteristics

Conformity to standards	IEC/EN 61812-1 IEC/EN 61000-6-1 IEC/EN 61000-6-2 IEC/EN 61000-6-3 IEC/EN 61000-6-4
Certifications	CE, UL, cUL, CSA, GL
Temperature limits use (°C)	-20 →+60
Temperature limits stored (°C)	-30 →+60
Installation category (acc. to IEC/EN 60664-1)	Voltage surge category III
Creepage distance and clearance acc. to IEC/EN 60664-1	4 kV / 3 mm
Protection (IEC/EN 60529)	IP20 IP40
Degree of protection acc. to IEC/EN 60529 Front face	IP50
Vibration resistance acc. to IEC/EN 60068-2-6	20 m/s ² 10 Hz →150 Hz
Relative humidity no condensation acc. to IEC/EN 60068-2-30	93 % non-condensing
Electromagnetic compatibility - Immunity to electrostatic discharges acc to IEC/EN 61000-4-2	Level III (Air 8 kV / Contact 6 kV)
Immunity to radiated, radio-frequency, electromagnetic field acc. IEC/EN 61000-4-3	Level I (1 V/m : 2,0 G Hz →2,7 G Hz) Level II (3 V/m : 1,4 G Hz →2,0 G Hz) Level III

	(10 V/m : 80 M Hz → 1 G Hz)
Immunity to rapid transient bursts acc. to IEC/EN 61000-4-4	Level III (direct 2 kV / Capacitive coupling clamp 1 kV)
Immunity to shock waves on power supply acc. to IEC/EN 61000-4-5	Level III (2 kV / common mode 2 kV/residual current mode 1 kV)
Immunity to radio frequency in common mode acc. to IEC/EN 61000-4-6	Level III (10V rms : 0.15 M Hz to 80 M Hz)
Immunity to voltage dips and breaks acc. to IEC/EN 61000-4-11	0 % residual voltage, 1 cycle 70 % residual voltage, 25/30 cycles
Mains-borne and radiated emissions acc. to EN 55022 (CISPR22), EN55011 (CISPR11)	Class B
Fixing : Symmetrical DIN rail	35 mm
Terminal capacity Single-wire without ferrule	1 x 0,5 → 3,3 mm ² (AWG 20 → AWG 12) 2 x 0,5 → 2,5 mm ² (AWG 20 → AWG 14)
Terminal capacity Multi-wire with ferrule	1 x 0,5 → 2,5 mm ² (AWG 20 → AWG 14) 2 x 0,5 → 1,5 mm ² (AWG 20 → AWG 16)
Housing material	Self-extinguishing
Shock test IEC/EN 60068-2-27	15 g - 11 ms
Short interruption on power line acc to IEC/EN 61000-4-11	0 % residual voltage, 250/300 cycles

Timing

Minimum pulse duration typically	30 ms
Minimum pulse duration typically (under load)	100 ms
Maximum reset time by de-energisation typically	120 ms

Supply

Operating range	85 → 110 % Un
Max. absorbed power	15 VA (400 VAC) 50 VA (240 VAC) 0,7 W (24 VDC) 1,2 VA (12 VAC) 0,5 W (12 VDC)

Output specification

2 changeover relays, AgNi (cadmium-free)	2 C/O
--	-------

General characteristics

Weight : casing 22,5 mm	88 866 175 (RQR1) : 81 g 88 866 176 (RQR6) : 81 g 88 866 215 (RA2R1) : 87 g 88 866 300 (RU2R4) : 86 g 88 866 303 (RU2R3) : 90 g 88 866 305 (RU2R1) : 88 g 88 866 385 (RX2R1) : 88 g
Insulation resistance according to IEC/EN 60664-1	> 500 MΩ (500 VDC)

Dimensions (mm)

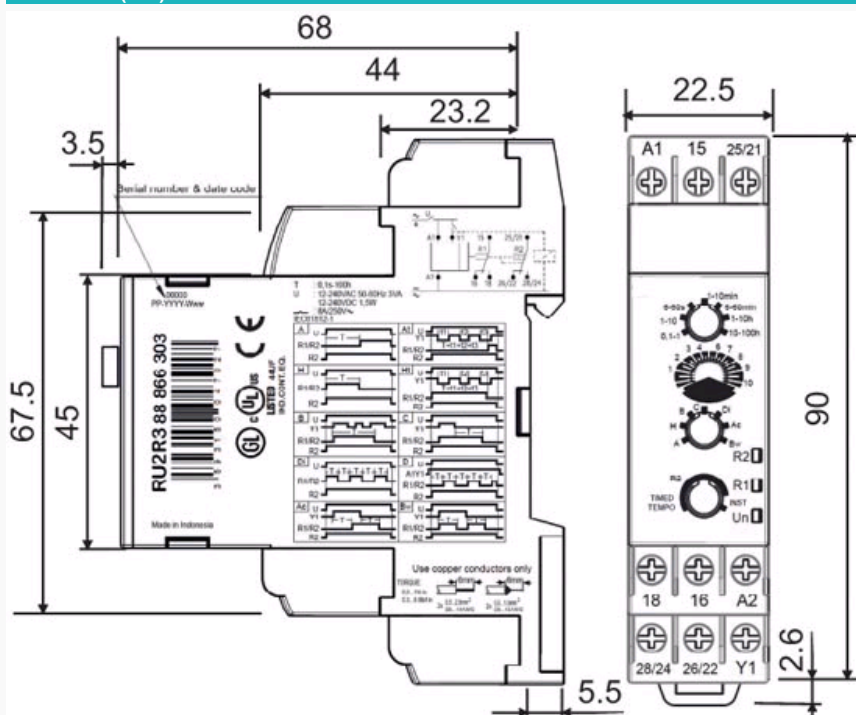

Curves

Function A

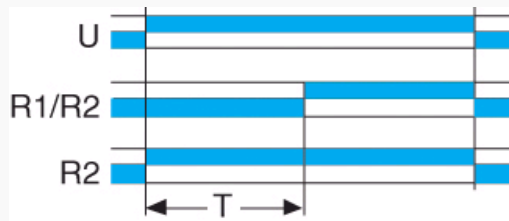

Function A
 Delay on energisation

Curves

Function Ac

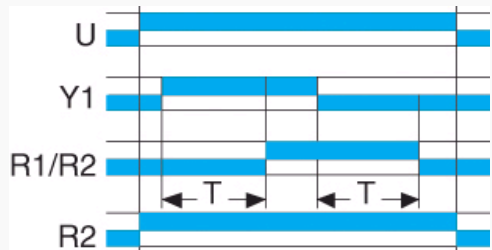

Function Ac
 Timing after closing and opening of control contact

Curves

Function At

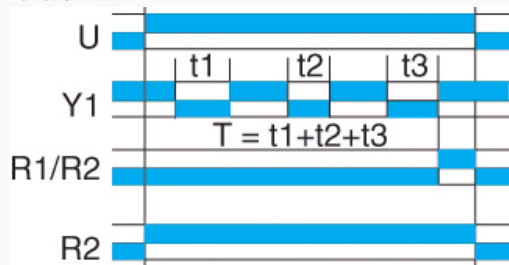

Function At
 Timing on energisation with memory

Curves

Function B

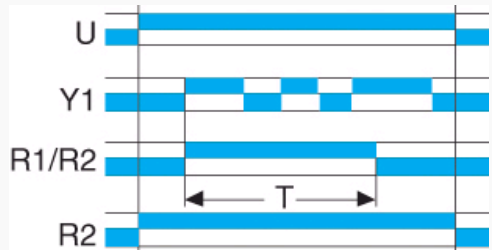

Function B
 Timing on impulse one shot

Curves

Function Bw

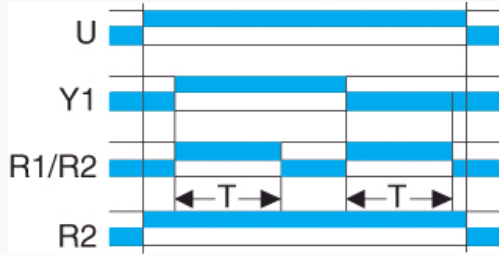

Function Bw

Pulse output (adjustable)

Curves

Function C

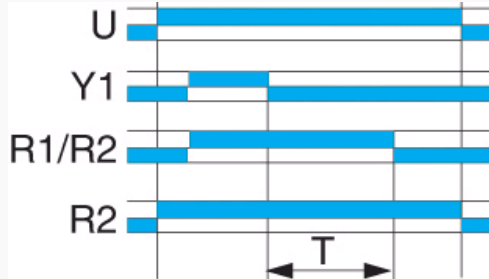

Function C

Timing after impulse delay OFF

Curves

Function D



Function D

Flip-flop Pause start

Curves

Function Di

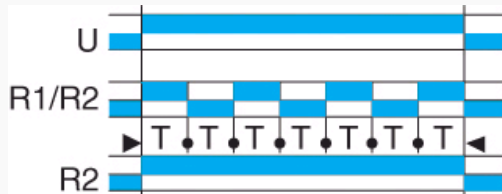

Function Di

Flip-flop Pulse start

Curves

Function H

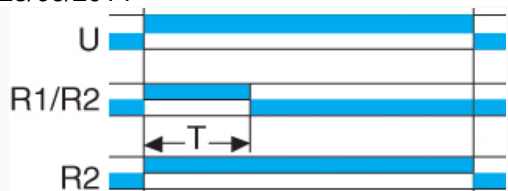

Function H
Timing on energisation

Curves

Function Ht

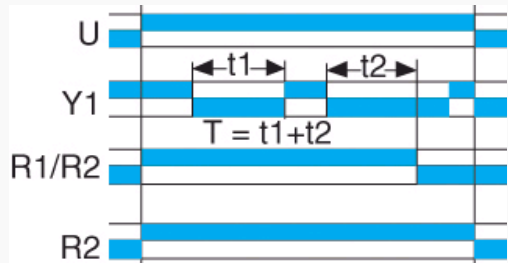

Function Ht
Delay on energisation with memory

Connections

2 changeover relay outputs

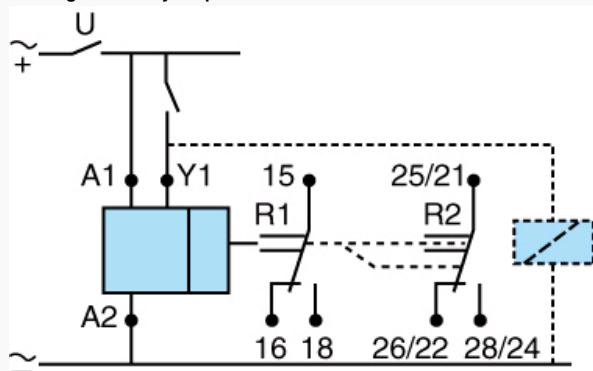

A - Ac - At - B - Bw - C - D - Di - H - Ht

Mouser Electronics

Authorized Distributor

Click to View Pricing, Inventory, Delivery & Lifecycle Information:

[Crouzet:](#)

[88866300](#)