

TOSHIBA BiCD Process Integrated Circuit Silicon Monolithic

## TB62D612FTG

### 24-Channel Constant-Current LED Driver of the 3.3-V or 5-V Power Supply Voltage Operation

The TB62D612FTG is a constant-current driver designed for LED and LED display lighting.

This product incorporates 7-bit PWM dimming controllers and 24 channels of constant-current drivers. 24 channels constant-current drivers are divided into three blocks, and each block can be independently adjusted by the relevant external resistor.

This product is controlled using the SDA and SCLK input signals, and capable of high-speed data transfers.

This product can be set address with ID setting pins. (Up to 64 addresses can be controlled independently.)

High-speed processing is capable by applying BiCD process.

This product operates with a supply voltage of 3.3 V or 5 V.

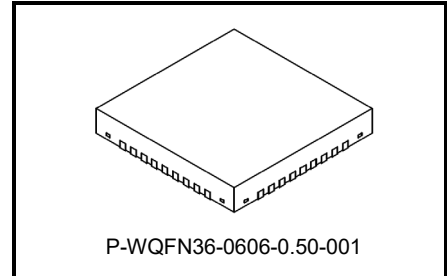

Weight: 0.083 g ( typ.)

### 1. Features

- Power supply voltages:  $V_{CC} = 3.3\text{ V}/5\text{ V}$
- Maximum output current capability: 80 mA (max) × 24 channels
- Constant-current output range: 5 to 40 mA
- Output voltage at constant-current drive: 0.4 V (min,  $I_{OUT} = 5$  to 40 mA)
- Designed for common-anode LEDs
- The input interface is controlled by the SDA and SCLK signal lines
- Thermal shutdown (TSD)
- Logical Input and output: 3.3-V or 5-V CMOS interfaces (Schmitt trigger input)
- Maximum output voltage: 28 V
- Incorporating PWM control circuitry: Provides 7-bit PWM control.
- Driver identification: Up to 64 driver ICs can be controlled individually.
- Operating temperature range:  $T_{opr} = -40$  to  $85^{\circ}\text{C}$
- Package: P-WQFN36-0606-0.50-001

- Constant-current accuracy

Condition	Constant-current accuracy between channels	Constant-current accuracy between ICs
Output voltage : 0.4 V Output current : 15 mA	± 3.0%	± 6.0%

## 2. Pin Assignment (top view)

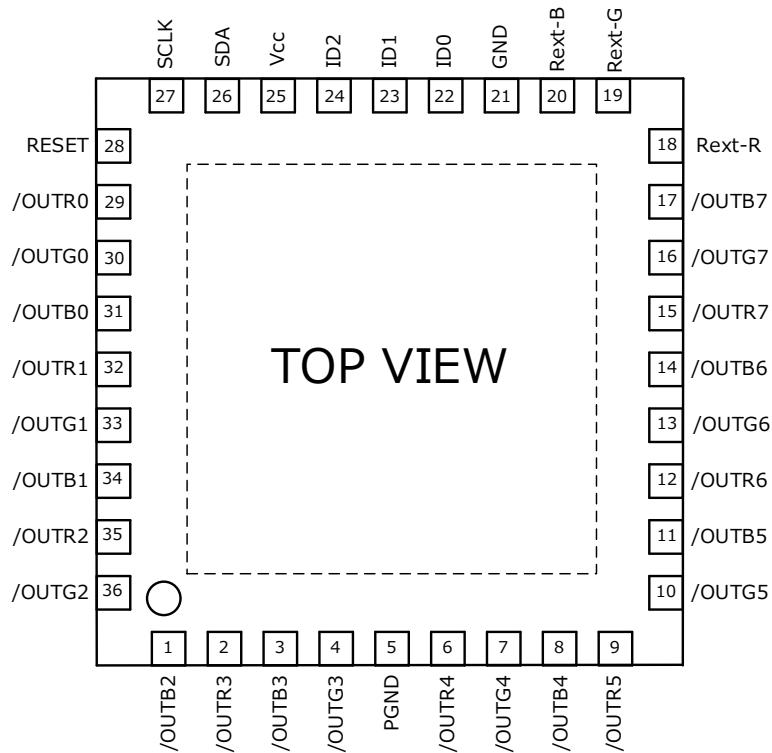

## 3. Block Diagram

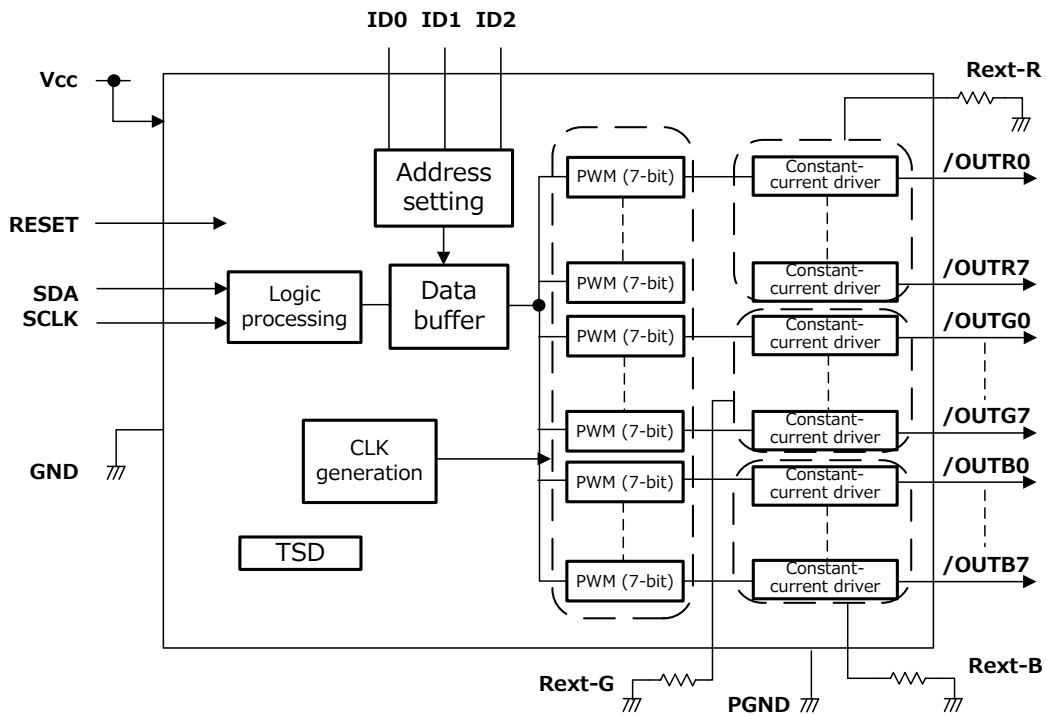

## 4. Terminal Description

Pin No	Symbol	Function
1	/OUTB2	Constant-current output pin (Open-drain type)
2	/OUTR3	Constant-current output pin (Open-drain type)
3	/OUTB3	Constant-current output pin (Open-drain type)
4	/OUTG3	Constant-current output pin (Open-drain type)
5	PGND	Power Ground pin
6	/OUTR4	Constant-current output pin (Open-drain type)
7	/OUTG4	Constant-current output pin (Open-drain type)
8	/OUTB4	Constant-current output pin (Open-drain type)
9	/OUTR5	Constant-current output pin (Open-drain type)
10	/OUTG5	Constant-current output pin (Open-drain type)
11	/OUTB5	Constant-current output pin (Open-drain type)
12	/OUTR6	Constant-current output pin (Open-drain type)
13	/OUTG6	Constant-current output pin (Open-drain type)
14	/OUTB6	Constant-current output pin (Open-drain type)
15	/OUTR7	Constant-current output pin (Open-drain type)
16	/OUTG7	Constant-current output pin (Open-drain type)
17	/OUTB7	Constant-current output pin (Open-drain type)
18	Rext-R	External resistor connection pin for output current configuration (/OUTR0 to /OUTR7)
19	Rext-G	External resistor connection pin for output current configuration (/OUTG0 to /OUTG7)
20	Rext-B	External resistor connection pin for output current configuration (/OUTB0 to /OUTB7)
21	GND	Ground pin
22	ID0	ID configuration pin (Note 1)
23	ID1	ID configuration pin (Note 1)
24	ID2	ID configuration pin (Note 1)
25	Vcc	Supply voltage pin
26	SDA	Serial data input pin
27	SCLK	Serial clock input pin
28	RESET	Reset signal input. (Setting this pin High resets internal data.) (Note 1)
29	/OUTR0	Constant-current output pin (Open-drain type)
30	/OUTG0	Constant-current output pin (Open-drain type)
31	/OUTB0	Constant-current output pin (Open-drain type)
32	/OUTR1	Constant-current output pin (Open-drain type)
33	/OUTG1	Constant-current output pin (Open-drain type)
34	/OUTB1	Constant-current output pin (Open-drain type)
35	/OUTR2	Constant-current output pin (Open-drain type)
36	/OUTG2	Constant-current output pin (Open-drain type)

Note 1: After the reset is released, it should be ensured that IDs (slave addresses) are properly configured.

## 5. Equivalent Circuits for Inputs and Outputs

### SDA and SCLK Terminals

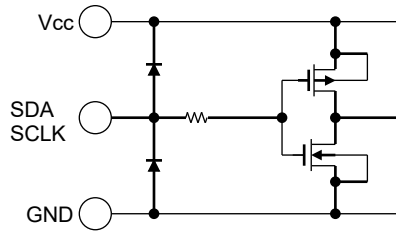

### RESET Terminals

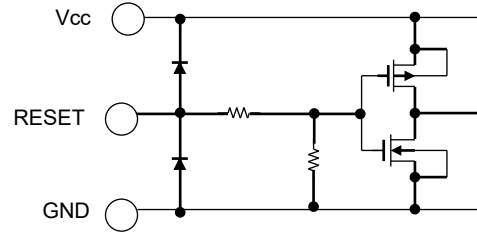

### Constant-Current Output Terminals

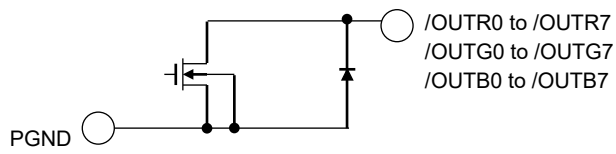

### ID0, ID1, and ID2 Terminals

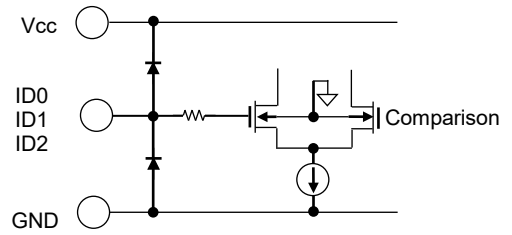

## 6. Programming the TB62D612FTG

The TB62D612FTG can be programmed by the SDA and SCLK signals.

The TB62D612FTG should be programmed using one of the following formats: (1) Serial Packet Format in Normal Programming Mode or (3) Serial Packet Format in Special Mode.

### (1) Serial Packet Format in Normal programming Mode

<Typical>

Start Command [11111111]	Slave address 8 bits	Sub-address (Channel select) 8 bits	Data byte (PWM configuration) 8 bits	Period Command [10000001]
-----------------------------	-------------------------	---	--	------------------------------

• Normal programming Mode should be set as the following flow.

“Start Command” → “Slave address” → “Sub-address” → “Data byte” → “Period Command”

As for example of data input, refer to Page8.

• Input data from SDA signal is written to the shift register at the rising edge of SCLK every 8 bit.

This data is transferred at the falling edge of the eighth CLK. So, at the eighth CLK, data should be input to the falling edge.

Block diagram of data setting part

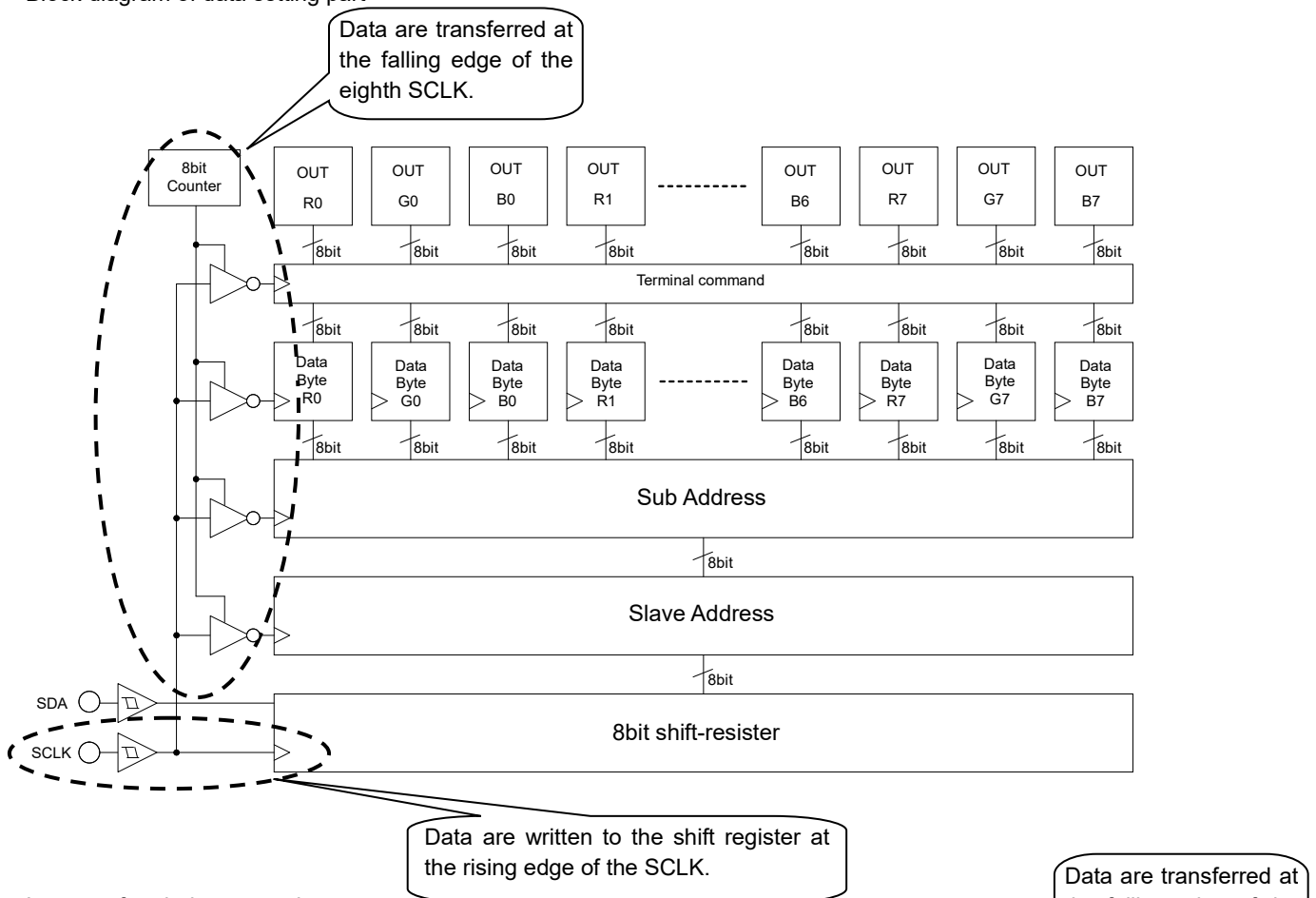

In case of period command

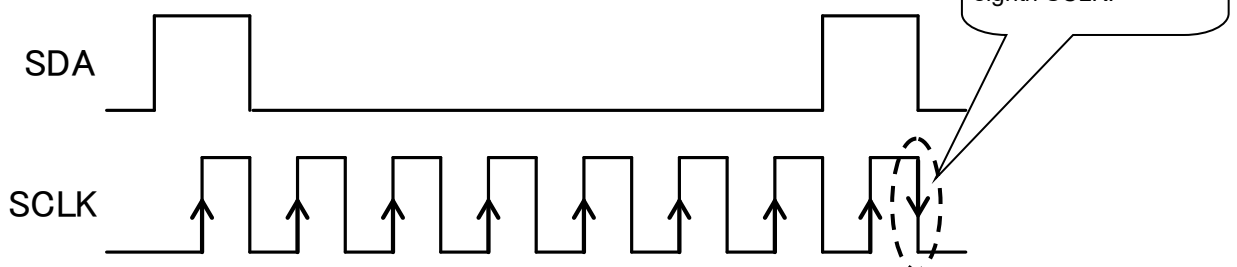

### (2) Data Settings

#### a) Slave Addresses

Input voltages and logic states of the ID0, ID1 and ID2 pins are determined as follows.

(MSB = 0. LSB = 0 (Except of all selection))

Vcc = "11", 2/3Vcc = "10", 1/3Vcc = "01", GND = "00"

Slave Addresses	ID2	ID1	ID0
00000000	GND	GND	GND
00000010	GND	GND	1/3Vcc
00000100	GND	GND	2/3Vcc
00000110	GND	GND	Vcc
00001000	GND	1/3Vcc	GND
00001010	GND	1/3Vcc	1/3Vcc
00001100	GND	1/3Vcc	2/3Vcc
00001110	GND	1/3Vcc	Vcc
00010000	GND	2/3Vcc	GND
00010010	GND	2/3Vcc	1/3Vcc
00010100	GND	2/3Vcc	2/3Vcc
00010110	GND	2/3Vcc	Vcc
00011000	GND	Vcc	GND
00011010	GND	Vcc	1/3Vcc
00011100	GND	Vcc	2/3Vcc
00011110	GND	Vcc	Vcc
00100000	1/3Vcc	GND	GND
00100010	1/3Vcc	GND	1/3Vcc
00100100	1/3Vcc	GND	2/3Vcc
00100110	1/3Vcc	GND	Vcc
00101000	1/3Vcc	1/3Vcc	GND
00101010	1/3Vcc	1/3Vcc	1/3Vcc
00101100	1/3Vcc	1/3Vcc	2/3Vcc
00101110	1/3Vcc	1/3Vcc	Vcc
00110000	1/3Vcc	2/3Vcc	GND
00110010	1/3Vcc	2/3Vcc	1/3Vcc
00110100	1/3Vcc	2/3Vcc	2/3Vcc
00110110	1/3Vcc	2/3Vcc	Vcc
00111000	1/3Vcc	Vcc	GND
00111010	1/3Vcc	Vcc	1/3Vcc
00111100	1/3Vcc	Vcc	2/3Vcc
00111110	1/3Vcc	Vcc	Vcc
01000000	2/3Vcc	GND	GND
01000010	2/3Vcc	GND	1/3Vcc
01000100	2/3Vcc	GND	2/3Vcc
01000110	2/3Vcc	GND	Vcc
01001000	2/3Vcc	1/3Vcc	GND
01001010	2/3Vcc	1/3Vcc	1/3Vcc
01001100	2/3Vcc	1/3Vcc	2/3Vcc
01001110	2/3Vcc	1/3Vcc	Vcc
01010000	2/3Vcc	2/3Vcc	GND
01010010	2/3Vcc	2/3Vcc	1/3Vcc
01010100	2/3Vcc	2/3Vcc	2/3Vcc
01010110	2/3Vcc	2/3Vcc	Vcc
01011000	2/3Vcc	Vcc	GND
01011010	2/3Vcc	Vcc	1/3Vcc
01011100	2/3Vcc	Vcc	2/3Vcc
01011110	2/3Vcc	Vcc	Vcc
01100000	Vcc	GND	GND
01100010	Vcc	GND	1/3Vcc
01100100	Vcc	GND	2/3Vcc

01100110	Vcc	GND	Vcc
01101000	Vcc	1/3Vcc	GND
01101010	Vcc	1/3Vcc	1/3Vcc
01101100	Vcc	1/3Vcc	2/3Vcc
01101110	Vcc	1/3Vcc	Vcc
01110000	Vcc	2/3Vcc	GND
01110010	Vcc	2/3Vcc	1/3Vcc
01110100	Vcc	2/3Vcc	2/3Vcc
01110110	Vcc	2/3Vcc	Vcc
01111000	Vcc	Vcc	GND
01111010	Vcc	Vcc	1/3Vcc
01111100	Vcc	Vcc	2/3Vcc
01111110	Vcc	Vcc	Vcc
0XXXXX1	All Select		

### b) Sub-Addresses

Output channel setting, All channels setting or Special mode setting can be set.

In output channel set, a channel which defines PWM configuration is selected. In all channels set, PWM is configured for all channels. For special mode, refer to page 8.

7bit	6bit	5bit	4bit	3bit	2bit	1bit	0bit	Channel set
0	0	0	0	0	0	1	0	/OUTR0
0	0	0	0	0	1	0	0	/OUTG0
0	0	0	0	0	1	1	0	/OUTB0
0	0	0	0	1	0	0	0	/OUTR1
0	0	0	0	1	0	1	0	/OUTG1
0	0	0	0	1	1	0	0	/OUTB1
0	0	0	0	1	1	1	0	/OUTR2
0	0	0	1	0	0	0	0	/OUTG2
0	0	0	1	0	0	1	0	/OUTB2
0	0	0	1	0	1	0	0	/OUTR3
0	0	0	1	0	1	1	0	/OUTG3
0	0	0	1	1	0	0	0	/OUTB3
0	0	0	1	1	0	1	0	/OUTR4
0	0	0	1	1	1	0	0	/OUTG4
0	0	0	1	1	1	1	0	/OUTB4
0	0	1	0	0	0	0	0	/OUTR5
0	0	1	0	0	0	1	0	/OUTG5
0	0	1	0	0	1	0	0	/OUTB5
0	0	1	0	0	1	1	0	/OUTR6
0	0	1	0	1	0	0	0	/OUTG6
0	0	1	0	1	0	1	0	/OUTB6
0	0	1	0	1	1	0	0	/OUTR7
0	0	1	0	1	1	1	0	/OUTG7
0	0	1	1	0	0	0	0	/OUTB7
0	1	0	0	0	0	0	0	All channels select
0	1	1	0	0	0	0	0	Special mode

(MSB and LSB must be set 0.)

### c) Data Bytes (PWM configuration)

Data bytes set PWM diming. (LSB must be set 0.)

7bit	6bit	5bit	4bit	3bit	2bit	1bit	0bit	PWM Dimming (for reference only)
0	0	0	0	0	0	0	0	OFF (Default)
0	0	0	0	0	0	1	0	1/127
0	0	0	0	0	1	0	0	2/127
								...
1	1	1	1	1	1	0	0	126/127
1	1	1	1	1	1	1	0	127/127

Note: Any data other than those specified above must not be programmed.

### (3) Serial Packet Format in Special Mode

When data of 01100000 is input to the sub address, the operation moves to the special mode where all channels are selected in order. Data of 24 channels should be input.

(If data of more than 24 channels are provided, the 25th and subsequent data are treated as invalid. If data of less than 24 channels are provided, those data are written to the channels in order and the remaining channels retain the previous data.)

To return to the normal mode, input data from the start command (ALL" H"8bit). In case of using this mode configuration, volume of data can be omitted.

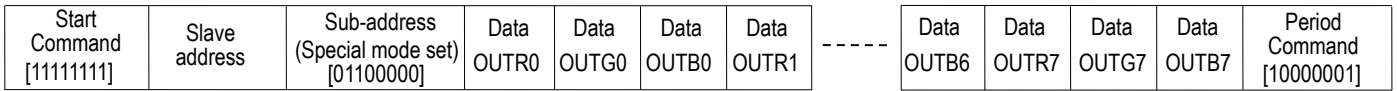

### (4) Input example of data set

a) In case PWM 127 /127(100% ON) are configured to all channels of slave address 00h.

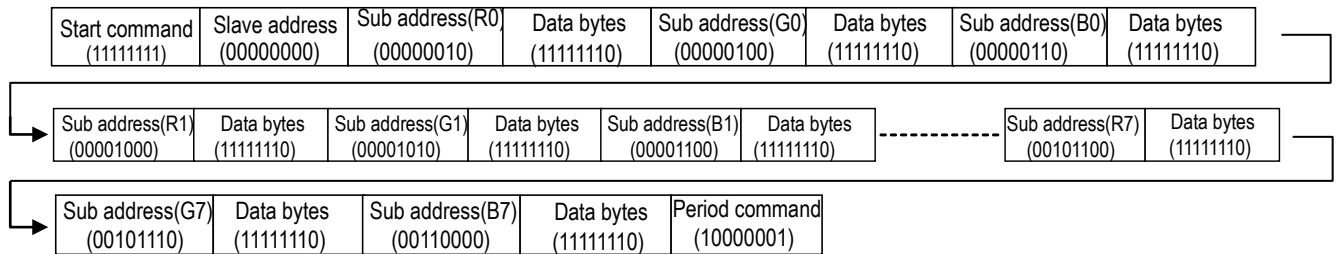

b) In case PWM 127 /127 (100% ON) are configured to only /OUTR0 pin and /OUTB7 pin of slave address 02h.

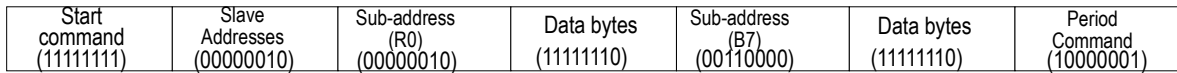

As for other than /OUTR0 and /OUTB7 terminals in above configuration, output pins which have already output data continue to output prior data. (In case of changing only outputting data which is required to be changed, this configuration is valid.)



## (5) Data settings and Timing of outputs

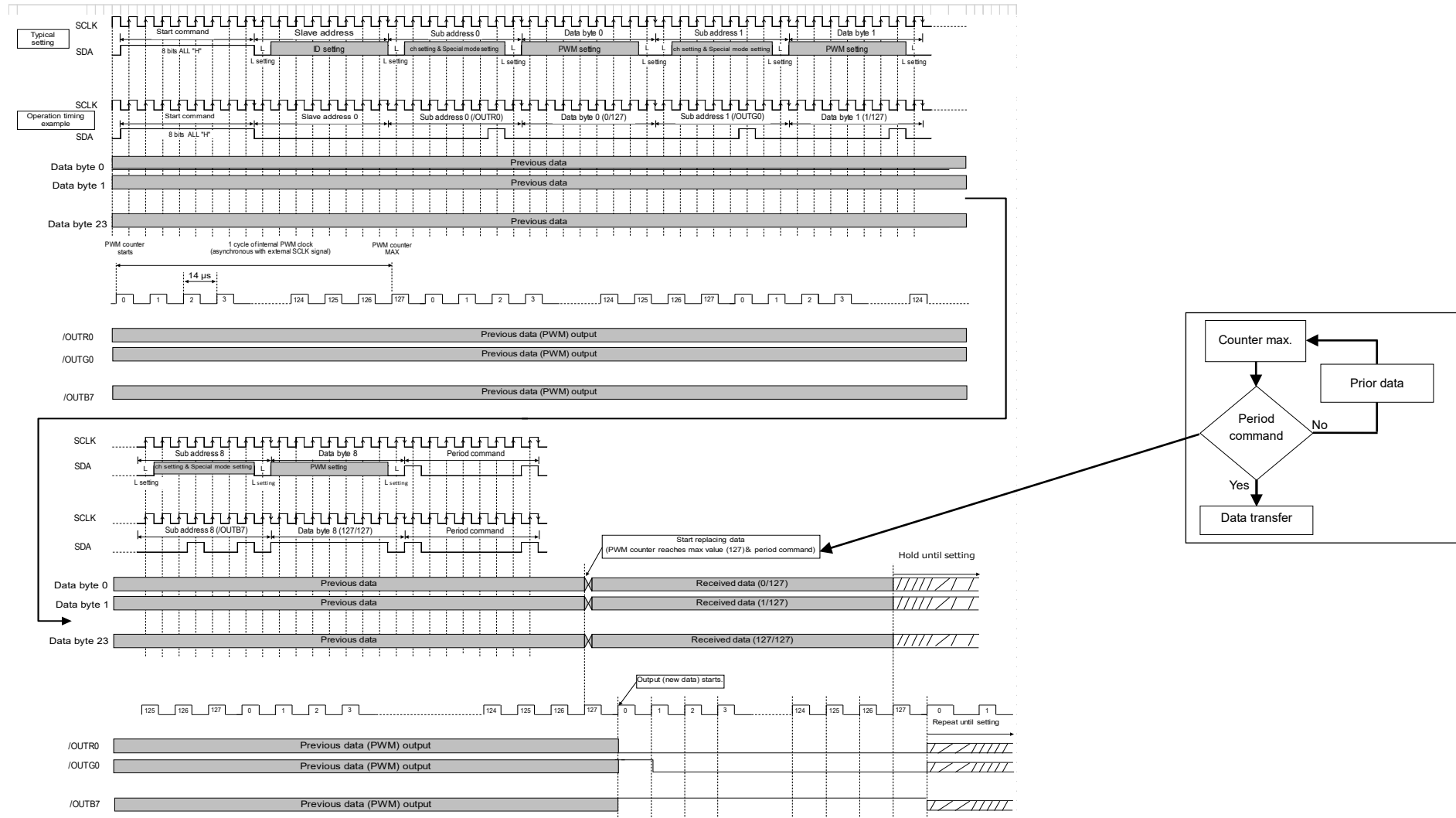

Note: Data is transferred by synchronizing period command (10000001) with the internal PWM counter (MAX). So, if data is input after the period command is input and before the internal PWM counter counts its maximum, data which is input after period input is not accepted. In order to set data to the same ID (IC), next data should be input after 3 ms which corresponds to 128 internal PWM clocks are passed since the period command is input. However, in order to set data to the different ID, terminal of 3 ms which corresponds to 128 internal PWM clocks should not be taken. Data is written to the shift register at the rising edge of SCLK every 8 bits, and is transferred at the falling edge of 8th CLK. So, data should be input to the falling edge at the 8th CLK.

(6) Example of data input to the same ID

a) In case data A is input up to the rising edge of 127th internal PWM clock.

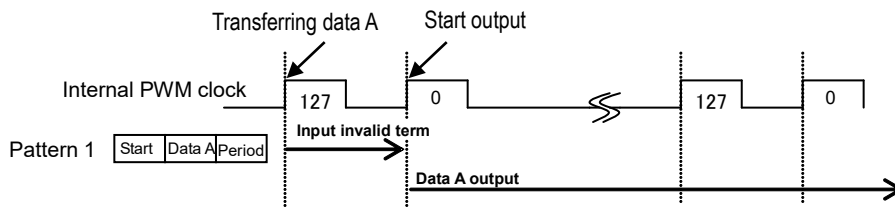

Outputting data A starts at the rising edge of 0th internal PWM clock.

Inputting is invalid from the rising edge of 127th internal PWM clock to the rising edge of 0th internal PWM clock which is just after this 127th PWM clock.

b) In case data A is input after the rising edge of 127th internal PWM clock.

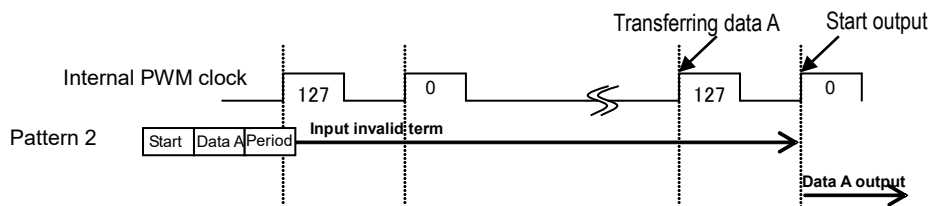

Outputting data A does not start at the rising edge of 0th internal PWM clock just after the data A is input. It starts at the next rising edge of 0th internal PWM clock.

Inputting is invalid from the period command of data A input to the rising edge of after the next 0th internal PWM clock.

c) In case data B is input after data of pattern 1 starts outputting.

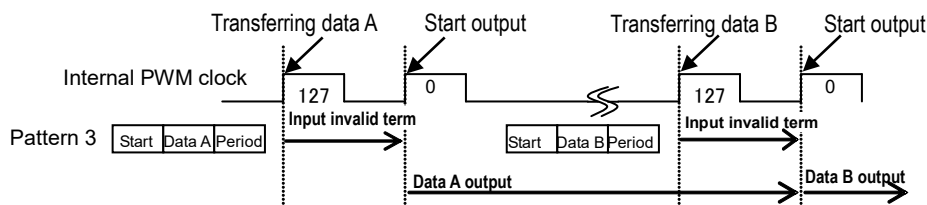

Outputting data A starts at the rising edge of 0th internal PWM clock just after the data A is input. Outputting data B starts at the rising edge of 0th internal PWM clock which is just after the data B input.

Inputting is invalid in the following term.

From the rising edge of 127th internal PWM clock which is just after the data A is input to the rising edge of 0th internal PWM clocks which is just after this 127th clock.

From the rising edge of 127th internal PWM clock which is just after the data B input to the rising edge of 0th internal PWM clock which is just after this 127th clock.

Pay attention that the IC does not operate according to the configuration while the following patterns (patterns 4 and 5) are input.

d) In case data B is input by the time the output of pattern 2 starts.

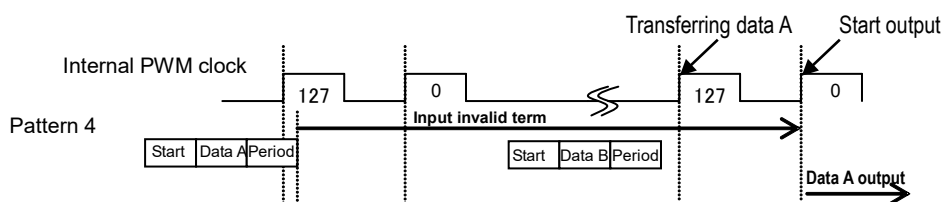

Inputting is invalid from the period command of data A input to the rising edge of the second internal clock. So, data B is invalid and data A is output.

e) In case the period command mistakes.

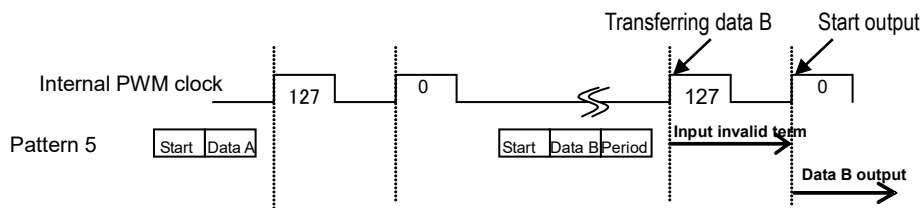

Outputting data A does not start at the rising edge of 0th internal clock which is just after the data A input. Outputting data B starts at the rising edge of 0th internal PWM clock which is just after the data B input.

f) In case of matching asynchronously the timing between data pattern end and internal data update

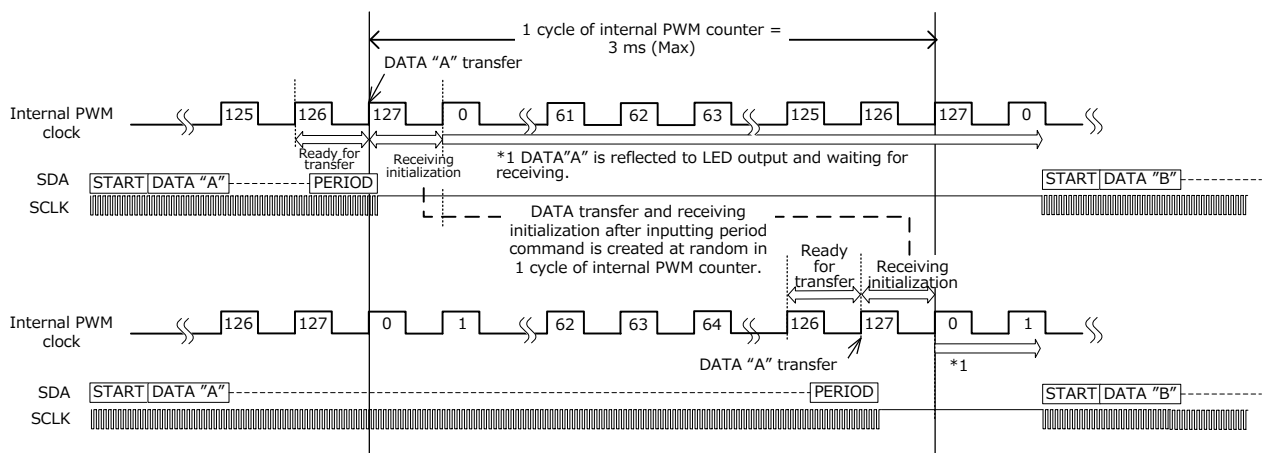

In case of matching asynchronously the timing between SCLK end and internal data update, the start command at the beginning of next pattern may not be received. That may occur in the pattern of first IC if there are patterns for two or more ICs. That does not occur if the pattern length is as follows.

1. Less than minimum 10.6  $\mu$ s after inputting period command
2. Exceeding maximum 3 ms from point of 1.

This time management is difficult. We recommend that the following measures are applied from initial state to avoid the occurrence of the event.

Dummy data are added to the beginning of the data pattern, and 1 time or more SCLKs should be added.

The following figure shows the dummy data = L. However, the dummy data =H is also possible.

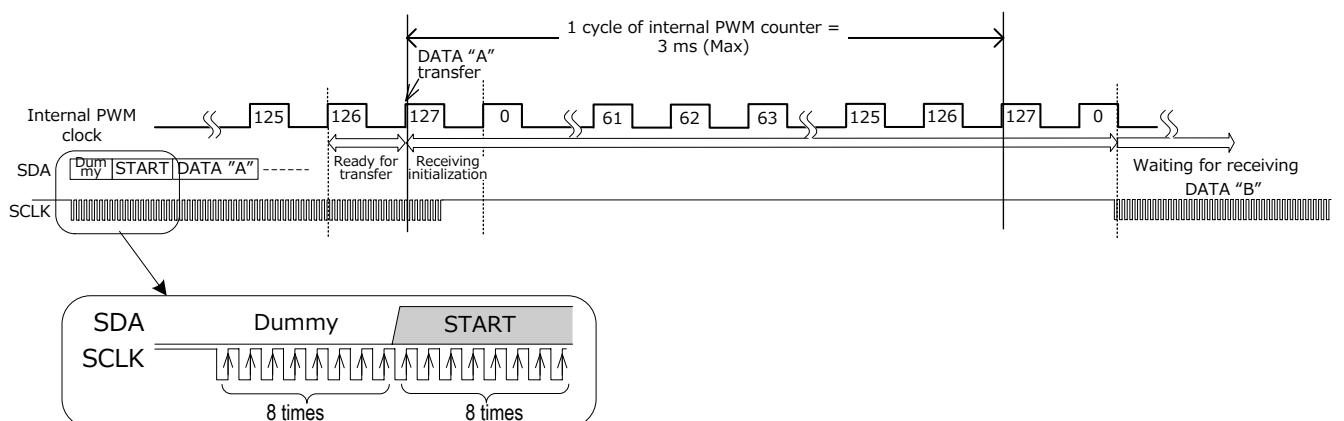

(7) Example of data input to the different ID.

- a) In case the data B is input to slave (= 02h) just after the data A is input to slave (= 00h).

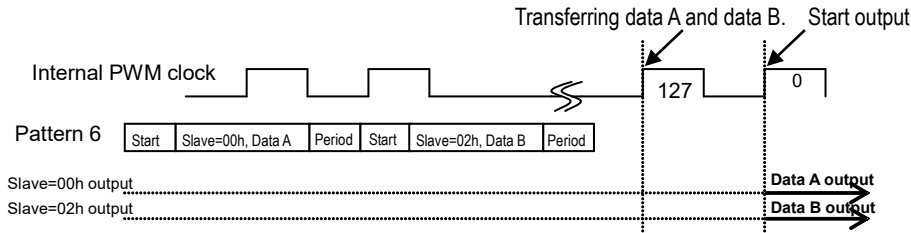

Both data A and data B are output at the rising edge of 0th internal PWM clock which is just after the data A and the data B inputs.

Pay attention that the IC does not operate according to the configuration while following patterns (patterns 7 and 8) are input.

- b) In case period command after inputting data A to the slave (=00h) is missed or omitted or in case period command after inputting data B to the slave (=02h) is missed or omitted.

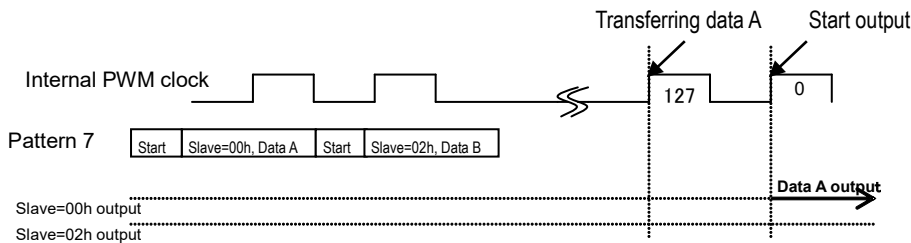

Data A is output. Data B is not output.

- c) In case start command is input after data B of pattern 7 is input.

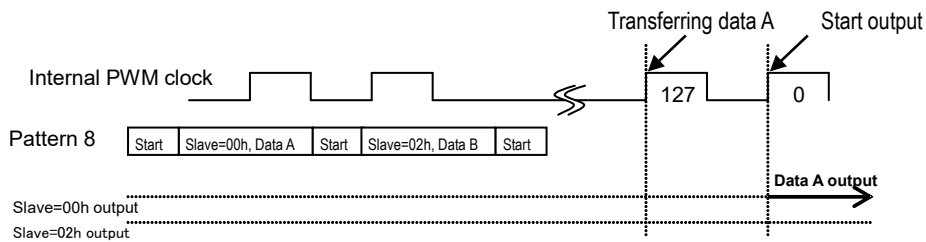

Data A is output. Data B is not output.

### 7. Power-ON Reset (POR)

The POR circuitry resets all the internal data to the default values upon powering up the TB62D612FTG in order to ensure proper device operation.

The POR circuitry is only activated when Vcc rises from 0 V. To reactivate POR, Vcc must be powered down to 0 V.

The internal data hold voltage is guaranteed after Vcc has once reached or exceeded 3.0 V.

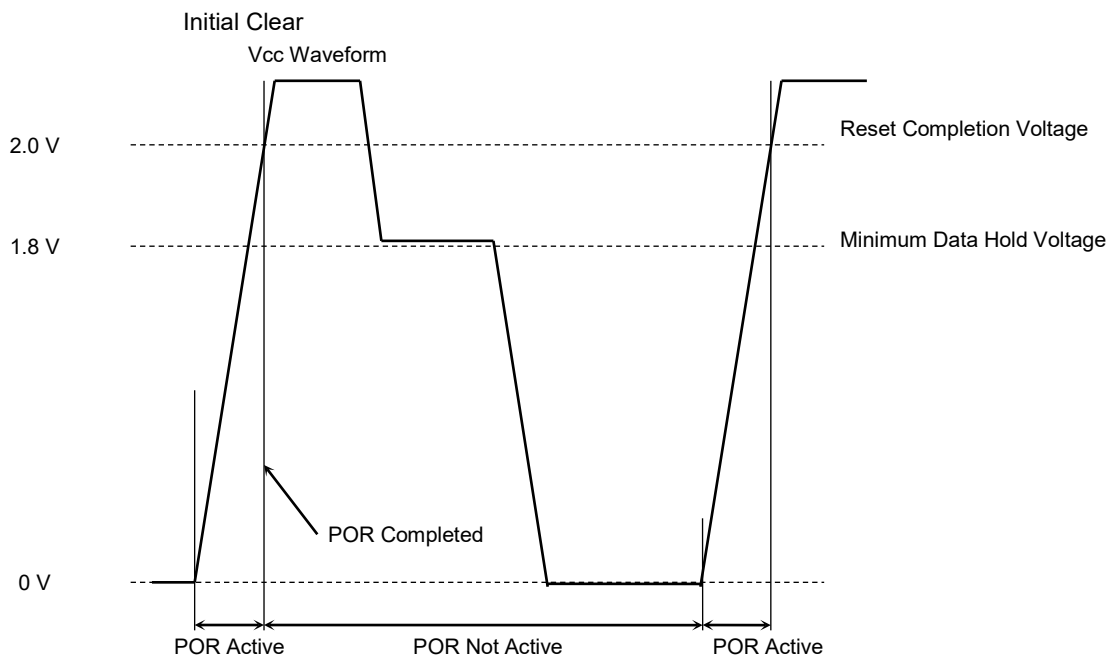

### 8. Thermal Shutdown (TSD)

When the IC internal temperature reaches 150°C, the thermal shutdown circuit operates and all constant current outputs are turned off. When the temperature falls, the constant current outputs restart.

TSD operating temperature: 150°C to 180°C

TSD release temperature: 30°C below TSD operating temperature

\*Please avoid positively using TSD because TSD is a detecting function of the product.

### 9. Points to Note when Setting Up the TB62D612FTG

- External resistors for specifying the LED driving current (Rext-R, Rext-G, Rext-B)**  
 External resistors should be separately connected to the Rext-R, Rext-G and Rext-B pins. Three resistors must not be collected as one resistor. If they are collected, current error is generated in each RGB.
- External resistors for ID configuration**  
 The total resistance value of three external resistors used for specifying a device ID (which are connected between Vcc and GND) should be about 30 kΩ or lower.
- ID configuration sequence**  
 ID configuration can be performed after POR is released upon powering on. However, to avoid false operation of the ID configuration, transient input signals of less than two clock cycles of the reference clock for the internal oscillator are not accepted.

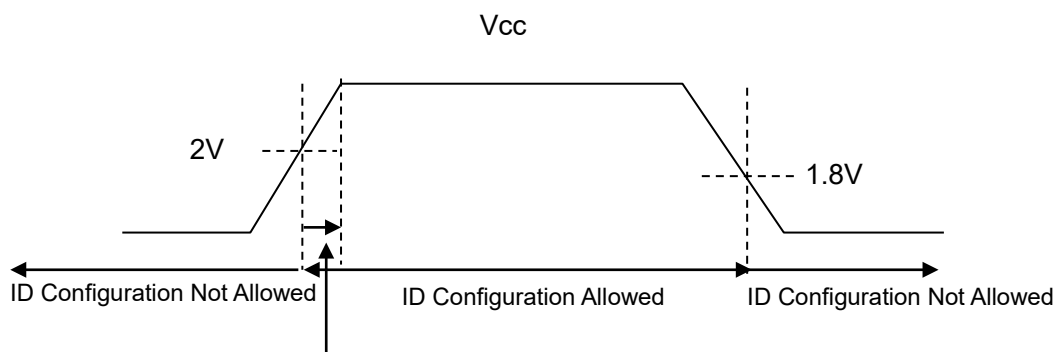

Care should be taken during the period between the POR released timing and the timing when power supply has reached the rated Vcc voltage.

- ID configuration**  
 Make sure to set IDs after releasing reset condition.
- Data configuration**  
 Do not input the data which is not on the list of the data configuration table in page 6 and 7.  
 Data is written to the shift register at the rising edge of SCLK every 8 bits. And data is transferred at the falling edge of the eighth clock. So, input data to the falling edge at the eighth clock.
- Special mode**  
 Data which corresponds to 24 channels should be input. If data of more than 24 channels are provided, the 25th and subsequent data are treated as invalid. If data of less than 24 channels are provided, those data are written to the channels in order and the remaining channels retain the previous data.
- Timing of data configuration**  
 In order to set data to the same slave address, next data should be input after 3 ms which corresponds to 127 internal PWM clocks is passed since the period command is input. However, in order to set data to the different slave address, terminal of 3 ms which corresponds to 127 internal PWM clocks should not be taken.

## 10. State Transition Diagram

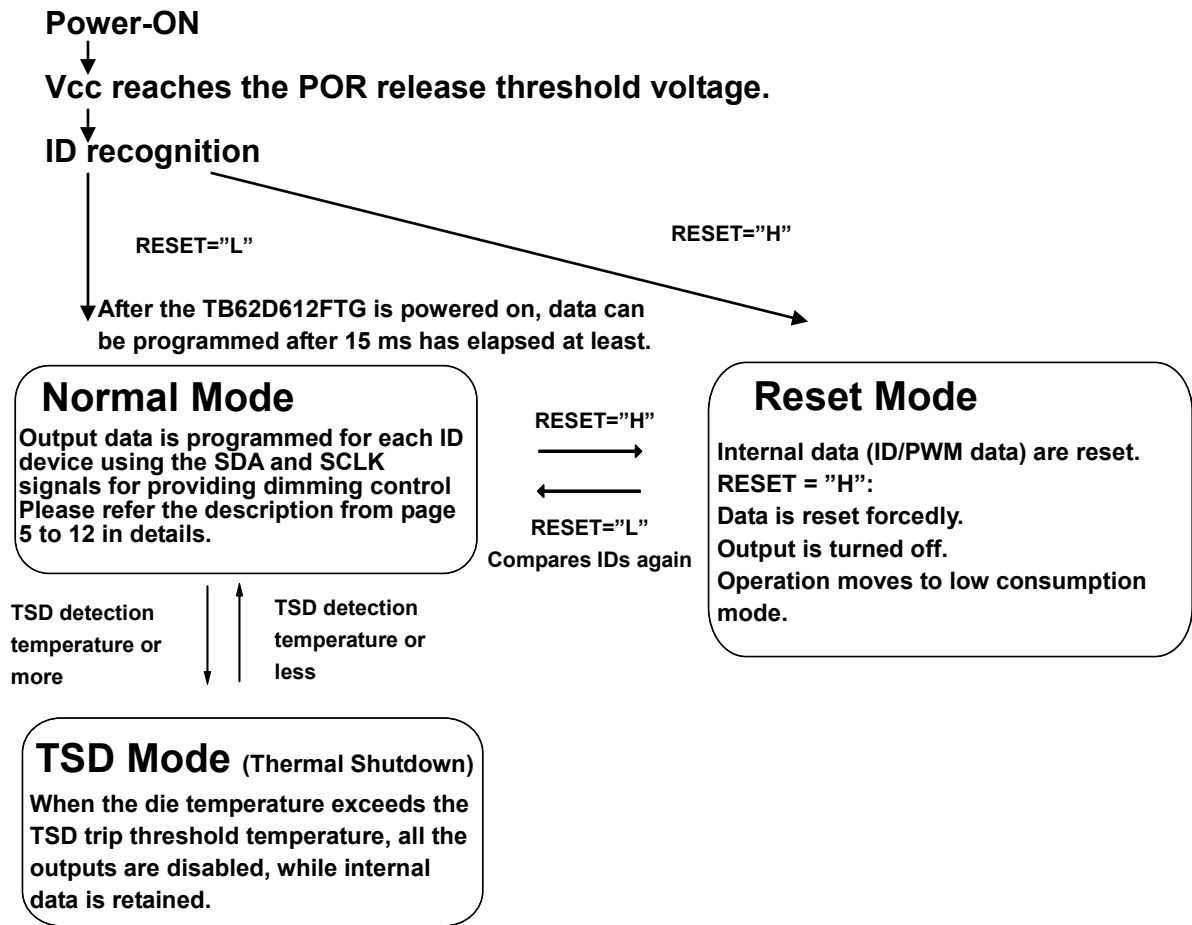

### 11. Absolute Maximum Ratings (Ta = 25°C)

Characteristics	Symbol	Rating	Unit
Supply voltage	V <sub>CC</sub>	6.0	V
Input voltage	V <sub>IN</sub>	-0.3 to V <sub>CC</sub> + 0.3 (Note 1)	V
Output current (/ch)	I <sub>OUT</sub>	85	mA
Output voltage	V <sub>OUT</sub>	-0.3 to 29	V
Power dissipation	P <sub>d</sub>	4.3 (Notes 2 and 3)	W
Thermal resistance	R <sub>th(j-a)</sub>	29 (Note 2)	°C / W
Operating temperature range	T <sub>opr</sub>	-40 to 85	°C
Storage temperature range	T <sub>stg</sub>	-55 to 150	°C
Maximum junction temperature	T <sub>j</sub>	150	°C

Note 1: However, do not exceed 6.0 V.

Note 2: When mounted on a PCB (76.2 × 114.3 × 1.6 mm; Cu = 30%; 35-μm-thick; SEMI-compliant, 4 layer)

Note 3: Power dissipation is reduced by 1/R<sub>th(j-a)</sub> for each °C above 25°C ambient.

### 12. Operating Ranges (Ta = -40°C to 85°C, unless otherwise specified)

Characteristics	Symbol	Test condition	Min	Typ.	Max	Unit
Supply voltage	V <sub>CC</sub>	-	3	-	5.5	V
Output voltage	V <sub>OUT</sub> (ON)	All Output	0.4	-	4	V
Output current (/ch)	I <sub>OUT</sub>	All Output	5	-	40	mA
Input voltage	V <sub>IH</sub>	SDA, SCLK, RESET	0.7 × V <sub>CC</sub>	-	V <sub>CC</sub>	V
	V <sub>IL</sub>		GND	-	0.3 × V <sub>CC</sub>	
	V <sub>ID0</sub>	ID0, ID1, ID2	0	-	0.3	
	V <sub>ID1</sub>		1/3V <sub>CC</sub> -0.3	1/3 V <sub>CC</sub>	1/3V <sub>CC</sub> +0.3	
	V <sub>ID2</sub>		2/3V <sub>CC</sub> -0.3	2/3 V <sub>CC</sub>	2/3V <sub>CC</sub> +0.3	
	V <sub>ID3</sub>		V <sub>CC</sub> -0.3	-	V <sub>CC</sub>	
SCLK clock frequency	f <sub>CLK</sub>	SCLK (Note. 4)	-	-	10	MHz
Data setup time	t <sub>SU;DAT</sub>	SDA-SCLK (Note. 4)	10	-	-	ns
Data hold time	t <sub>HD;DAT</sub>	SCLK-SDA (Note. 4)	10	-	-	
"L" term of SCLK clock	t <sub>LOW</sub>	SCLK (Note. 4)	50	-	-	
"H" term of SCLK clock	t <sub>HIGH</sub>	SCLK (Note. 4)	50	-	-	

Note. 4: Please refer to following timing chart.

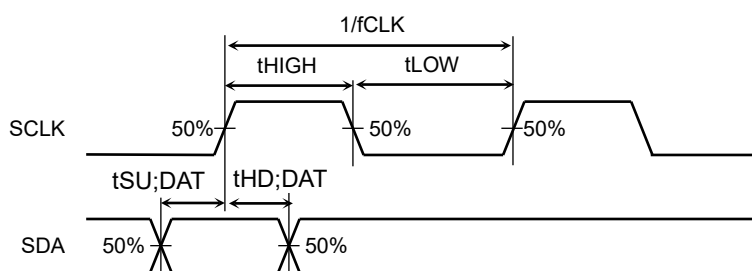



### 13. Electrical Characteristics (Ta = 25°C, Vcc = 4.5 to 5.5 V, unless otherwise specified)

Characteristics	Symbol	Test Circuit	Test Condition	Min	Typ.	Max	Unit
Output current	I <sub>OUT1</sub>	4	V <sub>OUT</sub> = 0.4 V, R <sub>EXT</sub> = 1.2kΩ V <sub>CC</sub> = 5 V,	12.69	13.5	14.31	mA
Output current accuracy between channels	ΔI <sub>OUT2</sub>	4	V <sub>OUT</sub> = 0.4 V, R <sub>EXT</sub> = 1.2kΩ All ch ON, V <sub>CC</sub> = 5 V	-	-	±3.0	%
Output leakage current	I <sub>OZ</sub>	4	V <sub>OUT</sub> = 28 V	-	-	1	μA
Input current	I <sub>IH</sub>	1	SDA, SCLK	-	-	1	μA
			RESET (V <sub>CC</sub> =5 V)	25	50	75	
	I <sub>IL</sub>	2	SDA, SCLK, RESET	-	-	-1	
	I <sub>ID</sub>	1,2	ID0, ID1, ID2	-	-	±0.1	
Changes in constant output current dependent on V <sub>CC</sub>	%V <sub>CC</sub>	4	V <sub>CC</sub> = 4.5 V to 5.5 V	-	1	2	%
Supply current at operating	I <sub>CC 1</sub>	3	R <sub>EXT</sub> =1.2 kΩ, V <sub>OUT</sub> =0.4 V, RESET=L	-	9	14	mA
	I <sub>CC 2</sub>	3	R <sub>EXT</sub> = OPEN, V <sub>OUT</sub> = 28.0 V	-	3	5	
Current consumption in Reset mode	I <sub>CC (PS)</sub>	3	R <sub>EXT</sub> = 1.2 kΩ, V <sub>OUT</sub> = 0.4 V, RESET = H (The input current of the RESET pin is excluded.)	-	-	1	μA
Time required for a mode transition from Reset mode to Normal mode	t <sub>ON2</sub> (Note1)	-	Time between a High to Low transition on RESET and the timing when an output current is generated after input data is applied.	-	-	3	ms

Note1: Internal data is reset forcedly by RESET pin. In order to turn on the output current, data should be input again. Pay attention that the output current flows after PWM counter counts its maximum (128 internal PWM clocks) though data are input again. RESET recovery time: 3 ms (MAX) <- In case the voltage is input until the PWM counter counts one cycle after RESET release. (After RESET release, PWM counter starts from zero.)

## 14. Test Circuits

Test Circuit 1: High-Level Input Current (I<sub>IH</sub>)

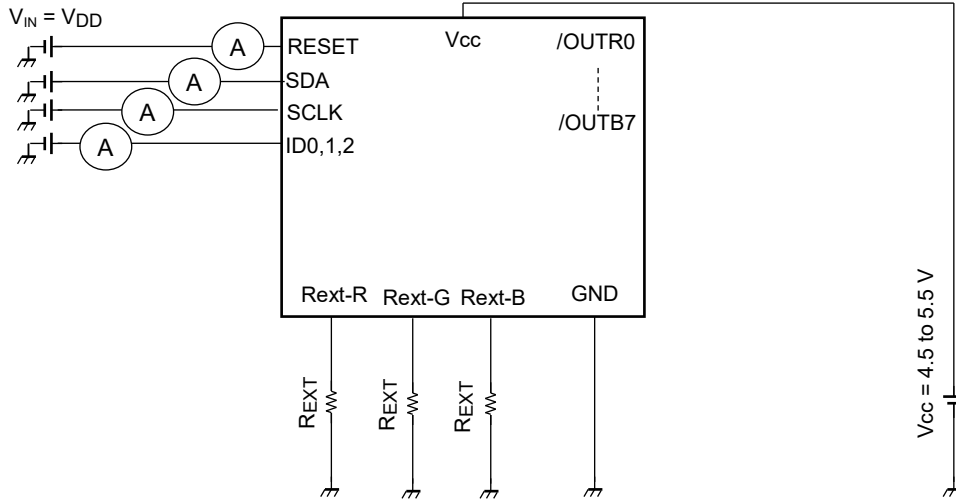

Test Circuit 2: Low-Level Input Current (I<sub>IL</sub>)

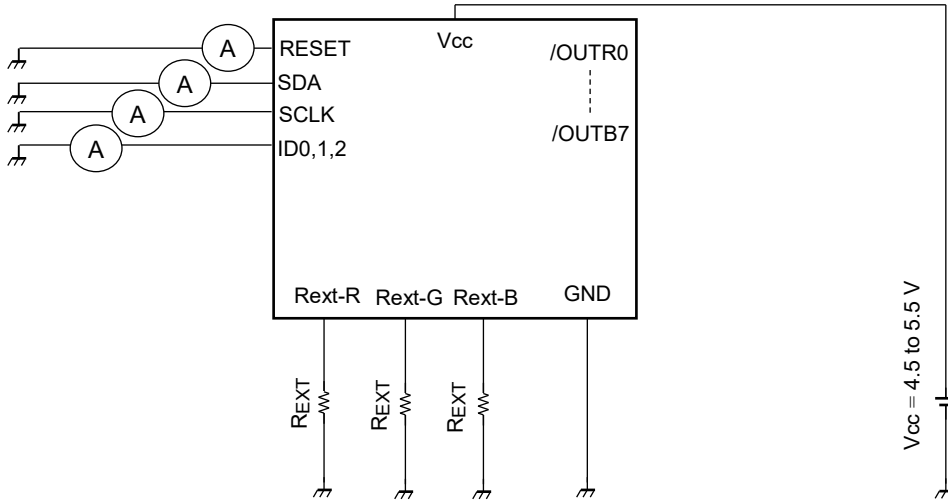

Test Circuit 3: Supply Current

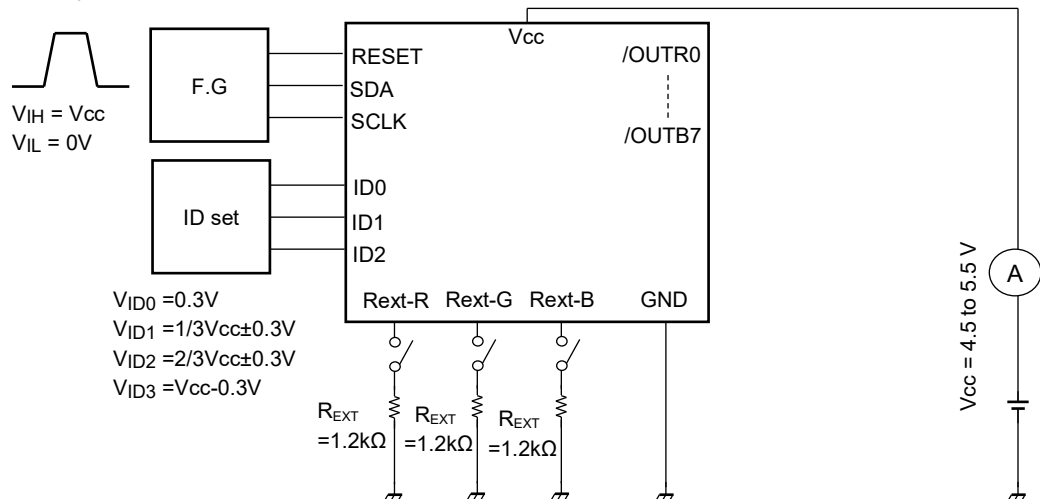

Test Circuit 4: Output Current, Output Leakage Current, Output current accuracy, Changes in constant output current dependent on Vcc

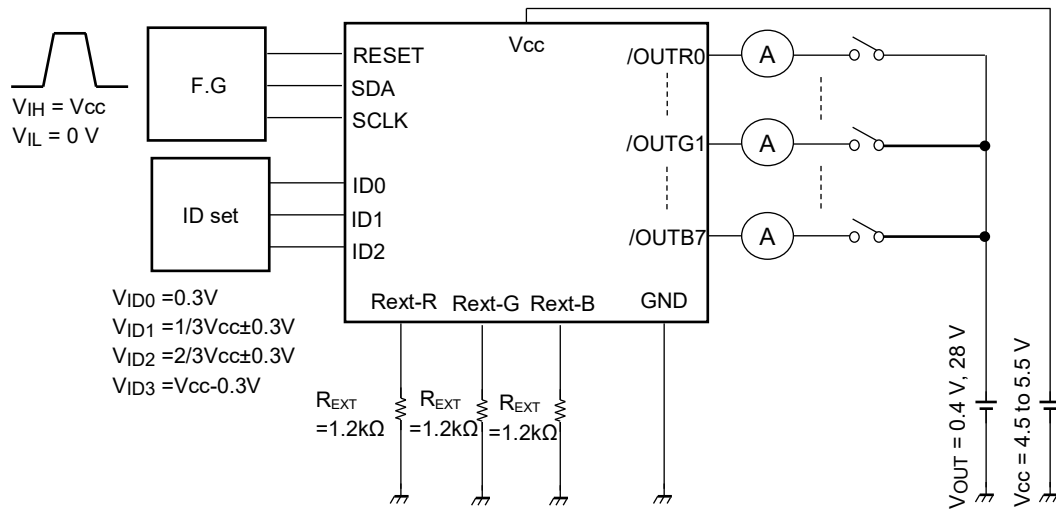

Test Circuit 5: Switching Characteristics

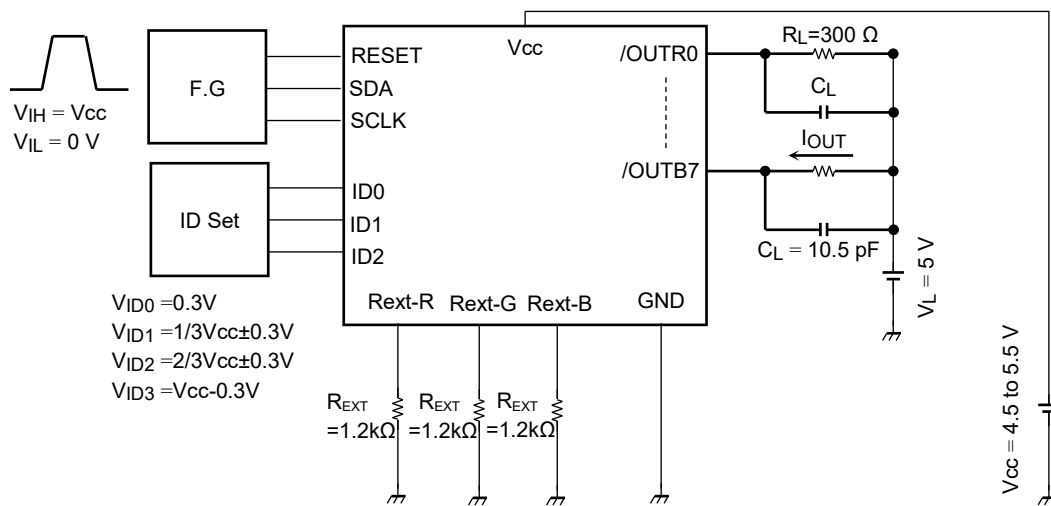

## 15. Characteristics of Output Current vs. External resistor (For reference)

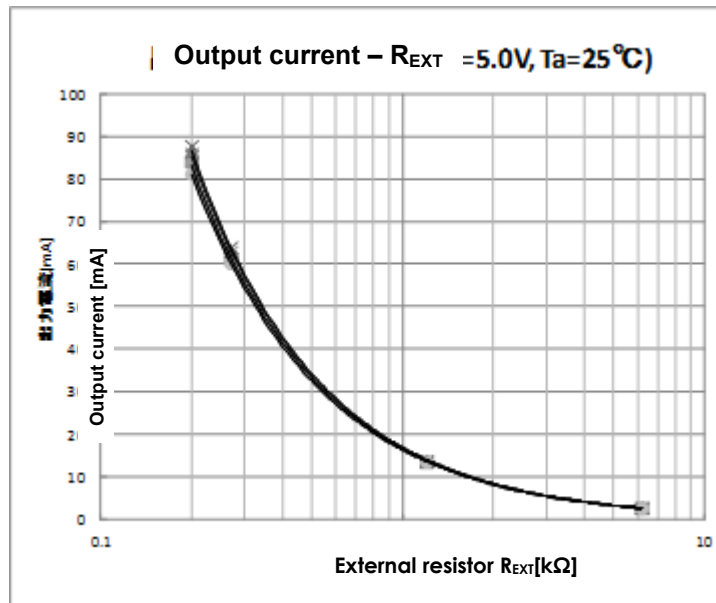

( Reference )

The TB62D612FTG IOOUT calculation.

The typical relational expression of the output-current and external resistor is shown below.

It is doesn't include a current accuracy.

The output-current ( mA ) =  $14.5 \times 1.12 / R_{EXT}$  ( kΩ )

## 16. Application Circuit Example

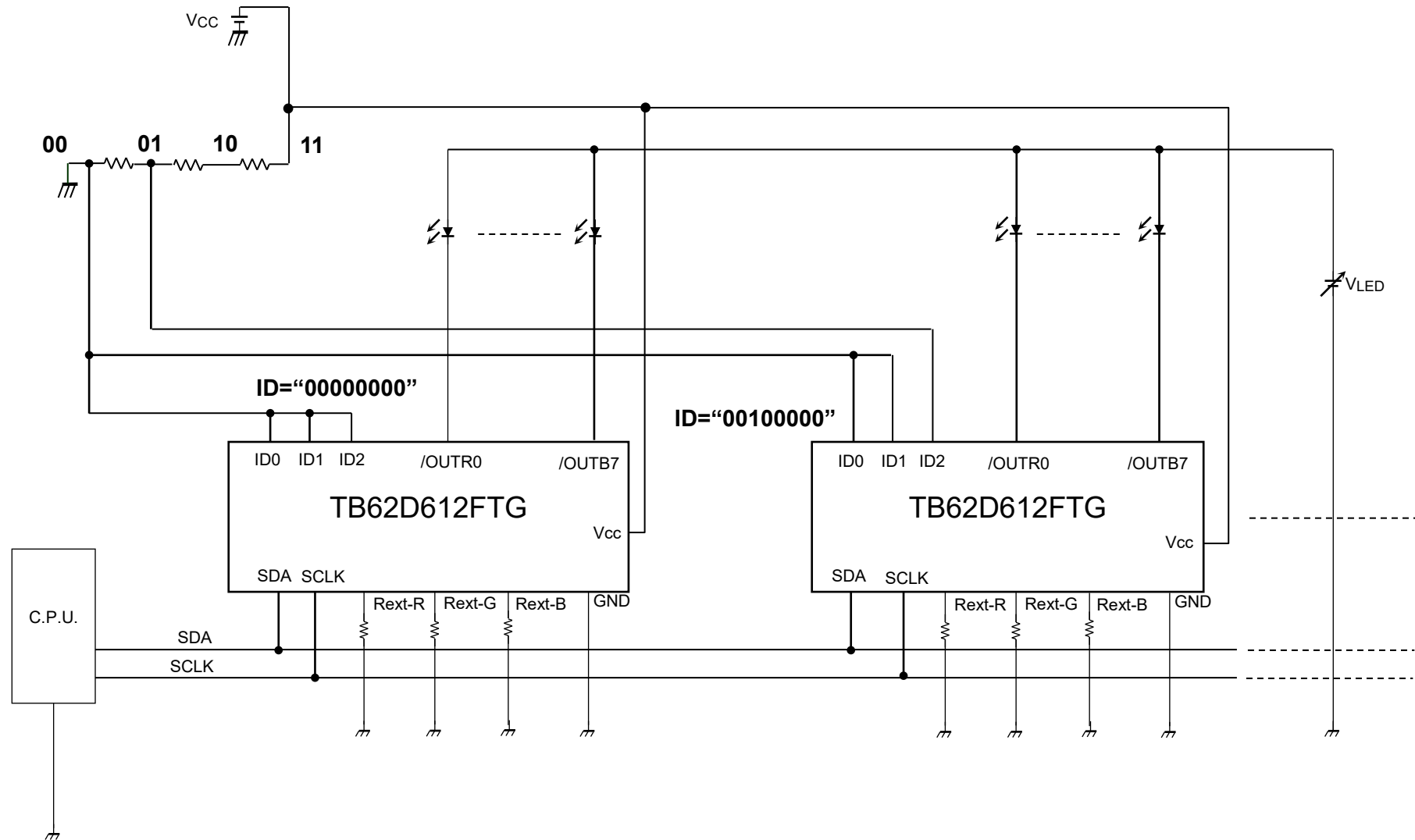



---

## Notes on Contents

### 1. Block Diagrams

Some of the functional blocks, circuits, or constants in the block diagram may be omitted or simplified for explanatory purposes.

### 2. Equivalent Circuits

The equivalent circuit diagrams may be simplified or some parts of them may be omitted for explanatory purposes.

### 3. Timing Charts

Timing charts may be simplified for explanatory purposes.

### 4. Application Examples

The application examples provided in this data sheet are provided for reference only. Thorough evaluation and testing should be implemented when designing your application's mass production design.

In providing these application examples, Toshiba does not grant the use of any industrial property rights.

### 5. Test Circuits

Components in the test circuits are used only to obtain and confirm the device characteristics. These components and circuits are not guaranteed to prevent malfunction or failure from occurring in the application equipment.

## IC Usage Considerations

### Notes on handling of ICs

- (1) The absolute maximum ratings of a semiconductor device are a set of ratings that must not be exceeded, even for a moment. Do not exceed any of these ratings.  
Exceeding the rating(s) may cause breakdown, damage or deterioration of the device, and may result in injury by explosion or combustion.
- (2) Use an appropriate power supply fuse to ensure that a large current does not continuously flow in the event of over current and/or IC failure. The IC will fully break down when used under conditions that exceed its absolute maximum ratings, when the wiring is routed improperly, or when an abnormal pulse noise occurs from the wiring or load, causing a large current to continuously flow. Such a breakdown can lead to smoke or ignition. To minimize effects of a large current flow in the event of breakdown, fuse capacity, fusing time, insertion circuit location, and other such suitable settings are required.
- (3) If your design includes an inductive load such as a motor coil, incorporate a protection circuit into the design to prevent device malfunction or breakdown caused by the current caused by inrush current at power ON or the negative current caused by the back electromotive force at power OFF. IC breakdown may cause injury, smoke or ignition.  
For ICs with built-in protection functions, use a stable power supply. An unstable power supply may cause the protection function to not operate, causing IC breakdown. IC breakdown may cause injury, smoke or ignition.
- (4) Do not insert devices incorrectly or in the wrong orientation.  
Make sure that the positive and negative terminals of power supplies are connected properly. Otherwise, the current or power consumption may exceed the absolute maximum rating, and exceeding the rating(s) may cause breakdown, damage or deterioration of the device, which may result in injury by explosion or combustion.  
In addition, do not use any device that has had current applied to it while inserted incorrectly or in the wrong orientation even once.

- (5) Carefully select power amp, regulator, or other external components (such as inputs and negative feedback capacitors) and load components (such as speakers),.  
If there is a large amount of leakage current such as input or negative feedback capacitors, the IC output DC voltage will increase. If this output voltage is connected to a speaker with low input withstand voltage, overcurrent or IC failure can cause smoke or ignition. (The over current can cause smoke or ignition from the IC itself.) In particular, please pay attention when using a Bridge Tied Load (BTL) connection type IC that inputs output DC voltage to a speaker directly.

### Points to remember on handling of ICs

- (1) Heat Dissipation Design  
In using an IC with large current flow such as a power amp, regulator or driver, please design the device so that heat is appropriately radiated, not to exceed the specified junction temperature ( $T_j$ ) at any time or under any condition. These ICs generate heat even during normal use. An inadequate IC heat dissipation design can lead to decrease in IC life, deterioration of IC characteristics or IC breakdown. In addition, please design the device taking into consideration the effect of IC heat dissipation on peripheral components.
- (2) Back-EMF  
When a motor reverses the rotation direction, stops, or slows down abruptly, a current flows back to the motor's power supply due to the effect of back-EMF. If the current sink capability of the power supply is small, the device's motor power supply and output pins might be exposed to conditions beyond absolute maximum ratings. To avoid this problem, take the effect of back-EMF into consideration in your system design.
- (3) Thermal Shutdown Circuit  
Thermal shutdown circuits do not necessarily protect ICs under all circumstances. If the thermal shutdown circuits operate against the over temperature, clear the heat generation status immediately.  
Depending on the method of use and usage conditions, such as exceeding absolute maximum ratings can cause the thermal shutdown circuit to not operate properly or IC breakdown before operation.



## RESTRICTIONS ON PRODUCT USE

Toshiba Corporation and its subsidiaries and affiliates are collectively referred to as "TOSHIBA". Hardware, software and systems described in this document are collectively referred to as "Product".

- TOSHIBA reserves the right to make changes to the information in this document and related Product without notice.
- This document and any information herein may not be reproduced without prior written permission from TOSHIBA. Even with TOSHIBA's written permission, reproduction is permissible only if reproduction is without alteration/omission.
- Though TOSHIBA works continually to improve Product's quality and reliability, Product can malfunction or fail. Customers are responsible for complying with safety standards and for providing adequate designs and safeguards for their hardware, software and systems which minimize risk and avoid situations in which a malfunction or failure of Product could cause loss of human life, bodily injury or damage to property, including data loss or corruption. Before customers use the Product, create designs including the Product, or incorporate the Product into their own applications, customers must also refer to and comply with (a) the latest versions of all relevant TOSHIBA information, including without limitation, this document, the specifications, the data sheets and application notes for Product and the precautions and conditions set forth in the "TOSHIBA Semiconductor Reliability Handbook" and (b) the instructions for the application with which the Product will be used with or for. Customers are solely responsible for all aspects of their own product design or applications, including but not limited to (a) determining the appropriateness of the use of this Product in such design or applications; (b) evaluating and determining the applicability of any information contained in this document, or in charts, diagrams, programs, algorithms, sample application circuits, or any other referenced documents; and (c) validating all operating parameters for such designs and applications. **TOSHIBA ASSUMES NO LIABILITY FOR CUSTOMERS' PRODUCT DESIGN OR APPLICATIONS.**
- **PRODUCT IS NEITHER INTENDED NOR WARRANTED FOR USE IN EQUIPMENTS OR SYSTEMS THAT REQUIRE EXTRAORDINARILY HIGH LEVELS OF QUALITY AND/OR RELIABILITY, AND/OR A MALFUNCTION OR FAILURE OF WHICH MAY CAUSE LOSS OF HUMAN LIFE, BODILY INJURY, SERIOUS PROPERTY DAMAGE AND/OR SERIOUS PUBLIC IMPACT ("UNINTENDED USE").** Except for specific applications as expressly stated in this document, Unintended Use includes, without limitation, equipment used in nuclear facilities, equipment used in the aerospace industry, lifesaving and/or life supporting medical equipment, equipment used for automobiles, trains, ships and other transportation, traffic signaling equipment, equipment used to control combustions or explosions, safety devices, elevators and escalators, and devices related to power plant. **IF YOU USE PRODUCT FOR UNINTENDED USE, TOSHIBA ASSUMES NO LIABILITY FOR PRODUCT.** For details, please contact your TOSHIBA sales representative or contact us via our website.
- Do not disassemble, analyze, reverse-engineer, alter, modify, translate or copy Product, whether in whole or in part.
- Product shall not be used for or incorporated into any products or systems whose manufacture, use, or sale is prohibited under any applicable laws or regulations.
- The information contained herein is presented only as guidance for Product use. No responsibility is assumed by TOSHIBA for any infringement of patents or any other intellectual property rights of third parties that may result from the use of Product. No license to any intellectual property right is granted by this document, whether express or implied, by estoppel or otherwise.
- **ABSENT A WRITTEN SIGNED AGREEMENT, EXCEPT AS PROVIDED IN THE RELEVANT TERMS AND CONDITIONS OF SALE FOR PRODUCT, AND TO THE MAXIMUM EXTENT ALLOWABLE BY LAW, TOSHIBA (1) ASSUMES NO LIABILITY WHATSOEVER, INCLUDING WITHOUT LIMITATION, INDIRECT, CONSEQUENTIAL, SPECIAL, OR INCIDENTAL DAMAGES OR LOSS, INCLUDING WITHOUT LIMITATION, LOSS OF PROFITS, LOSS OF OPPORTUNITIES, BUSINESS INTERRUPTION AND LOSS OF DATA, AND (2) DISCLAIMS ANY AND ALL EXPRESS OR IMPLIED WARRANTIES AND CONDITIONS RELATED TO SALE, USE OF PRODUCT, OR INFORMATION, INCLUDING WARRANTIES OR CONDITIONS OF MERCHANTABILITY, FITNESS FOR A PARTICULAR PURPOSE, ACCURACY OF INFORMATION, OR NONINFRINGEMENT.**
- Do not use or otherwise make available Product or related software or technology for any military purposes, including without limitation, for the design, development, use, stockpiling or manufacturing of nuclear, chemical, or biological weapons or missile technology products (mass destruction weapons). Product and related software and technology may be controlled under the applicable export laws and regulations including, without limitation, the Japanese Foreign Exchange and Foreign Trade Law and the U.S. Export Administration Regulations. Export and re-export of Product or related software or technology are strictly prohibited except in compliance with all applicable export laws and regulations.
- Please contact your TOSHIBA sales representative for details as to environmental matters such as the RoHS compatibility of Product. Please use Product in compliance with all applicable laws and regulations that regulate the inclusion or use of controlled substances, including without limitation, the EU RoHS Directive. **TOSHIBA ASSUMES NO LIABILITY FOR DAMAGES OR LOSSES OCCURRING AS A RESULT OF NONCOMPLIANCE WITH APPLICABLE LAWS AND REGULATIONS.**