

REAR VIEW

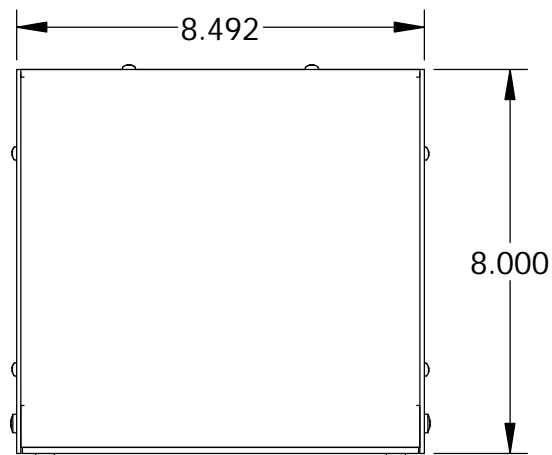

TOP VIEW

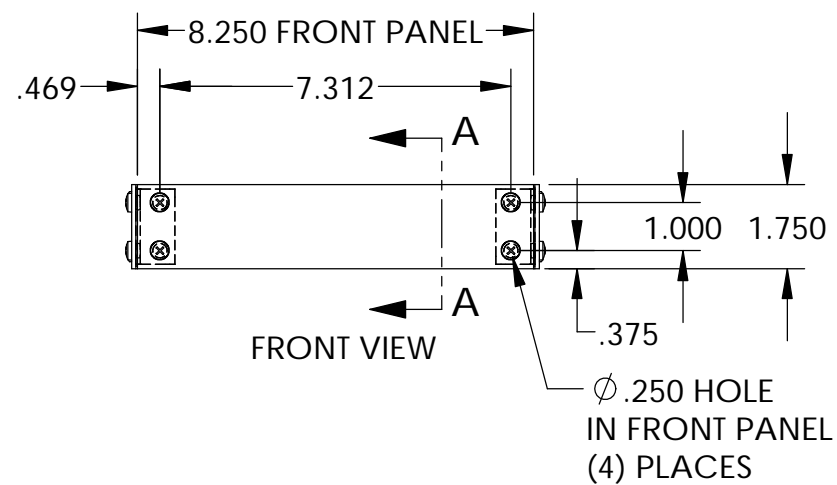

FRONT VIEW

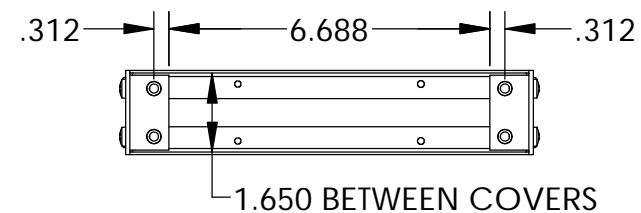

FRONT VIEW (LESS FRONT PANEL)

UNIT SHIPPED UNASSEMBLED.  
 OPTIONAL SELF-ADHESIVE RUBBER FEET (SUPPLIED)  
 LOAD RATING: 25 LBS. MAX.

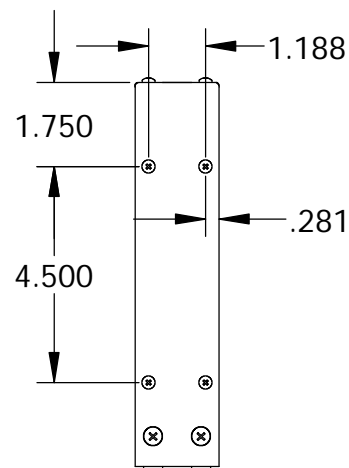

SIDE VIEW

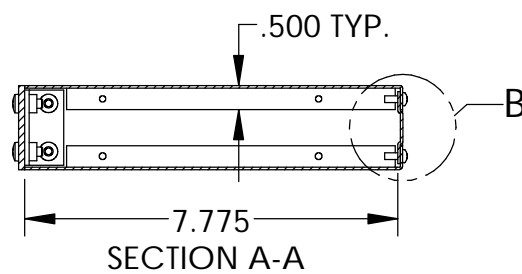

SECTION A-A

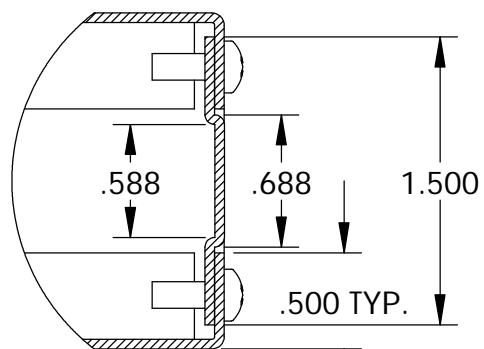

DETAIL B  
SCALE 4 : 1

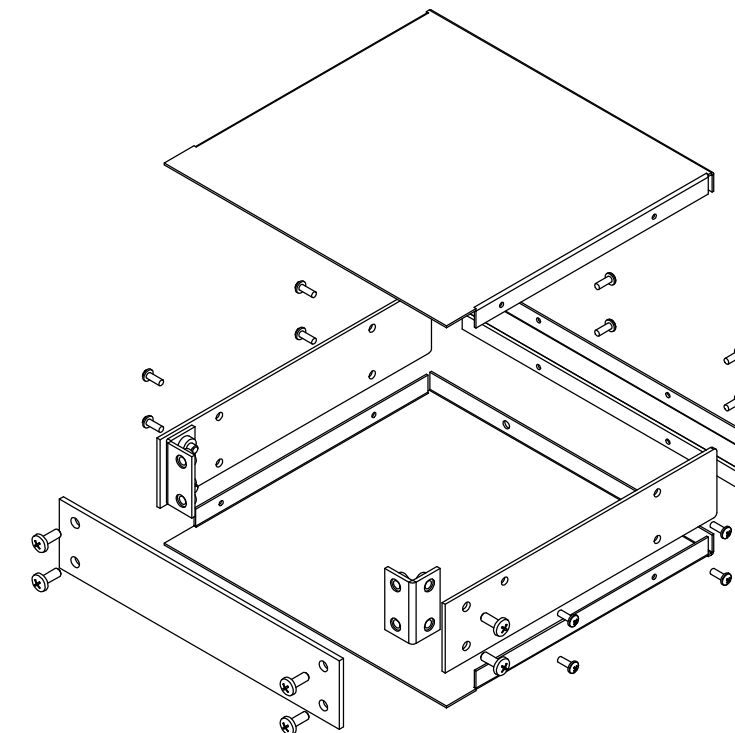

MATERIAL:  
 BACK & COVERS \_\_\_\_\_ 0.050 THICK ALUMINUM  
 SIDES & INNER BRACKETS \_\_\_\_\_ 0.090 THICK ALUMINUM  
 FRONT PANEL \_\_\_\_\_ 0.125 THICK ALUMINUM

FINISH:  
 BACK & COVERS \_\_\_\_\_ PREPAINTED SMOOTH WHITE  
 SIDES \_\_\_\_\_ WHITE TEXTURED  
 FRONT PANEL \_\_\_\_\_ NATURAL (OUTSIDE SURFACE TAPED WITH PVC)  
 INNER BRACKETS \_\_\_\_\_ NATURAL  
 FEET \_\_\_\_\_ BLACK

# Mouser Electronics

Authorized Distributor

Click to View Pricing, Inventory, Delivery & Lifecycle Information:

[Bud Industries:](#)

[NHC-14150](#)