

THIS DRAWING IS UNPUBLISHED. RELEASED FOR PUBLICATION
 © COPYRIGHT - TE Connectivity Ltd. ALL RIGHTS RESERVED.

REVISIONS					
P	LTR	DESCRIPTION	DATE	DWN	APVD
B		REV, RDRW, & SM PKG PER 0720-0040-93	9-26-93	TAB	DAP
B1		REVISED PER ECO-17-008808	03MAR2018	RS	DR

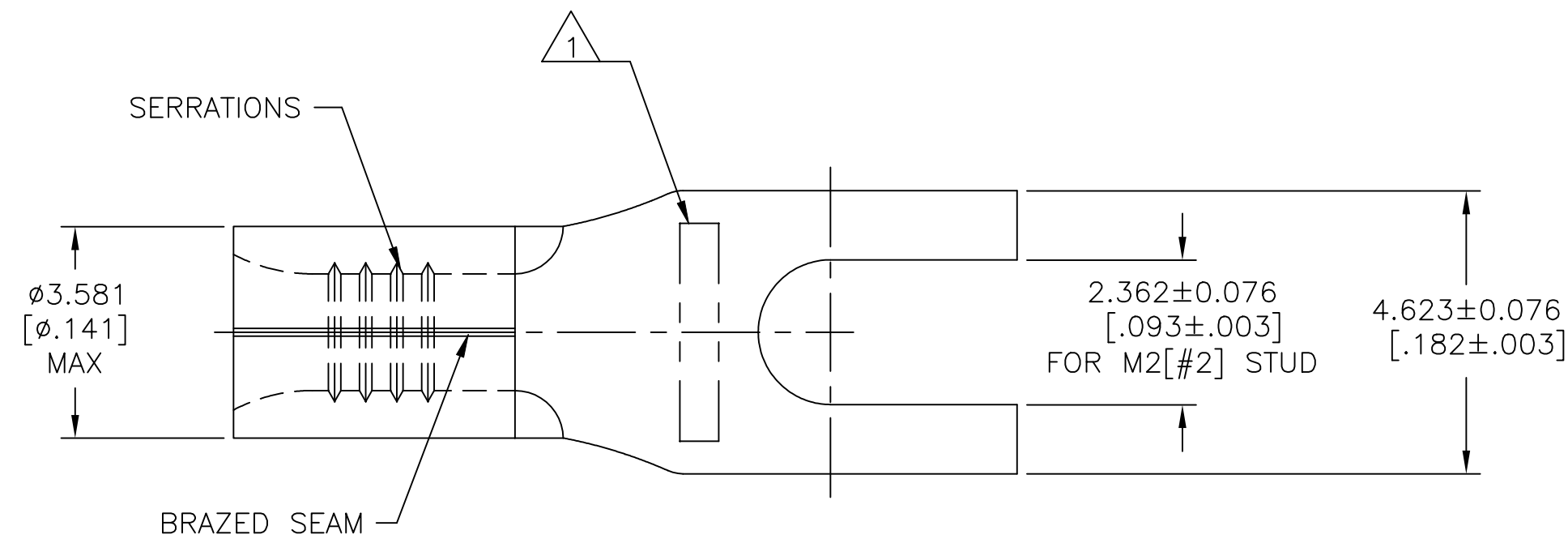

AMP WIRE RANGE	E13288 Listed
22-16 AWG SOLID OR STRANDED	22-16 AWG SOLID OR STRANDED
LR7189 Certified	MILITARY P/N AND CLASS
22-16 AWG SOLID OR STRANDED	NOT APPLICABLE

STAMP AMP 22-18* APPROX AS SHOWN
 22-16 TERMINALS ARE STAMPED 22-18 IN
 ACCORDANCE WITH MILITARY SPECIFICATION
 SAE AS7928, COMMERCIAL WIRE RANGE IS 22-16

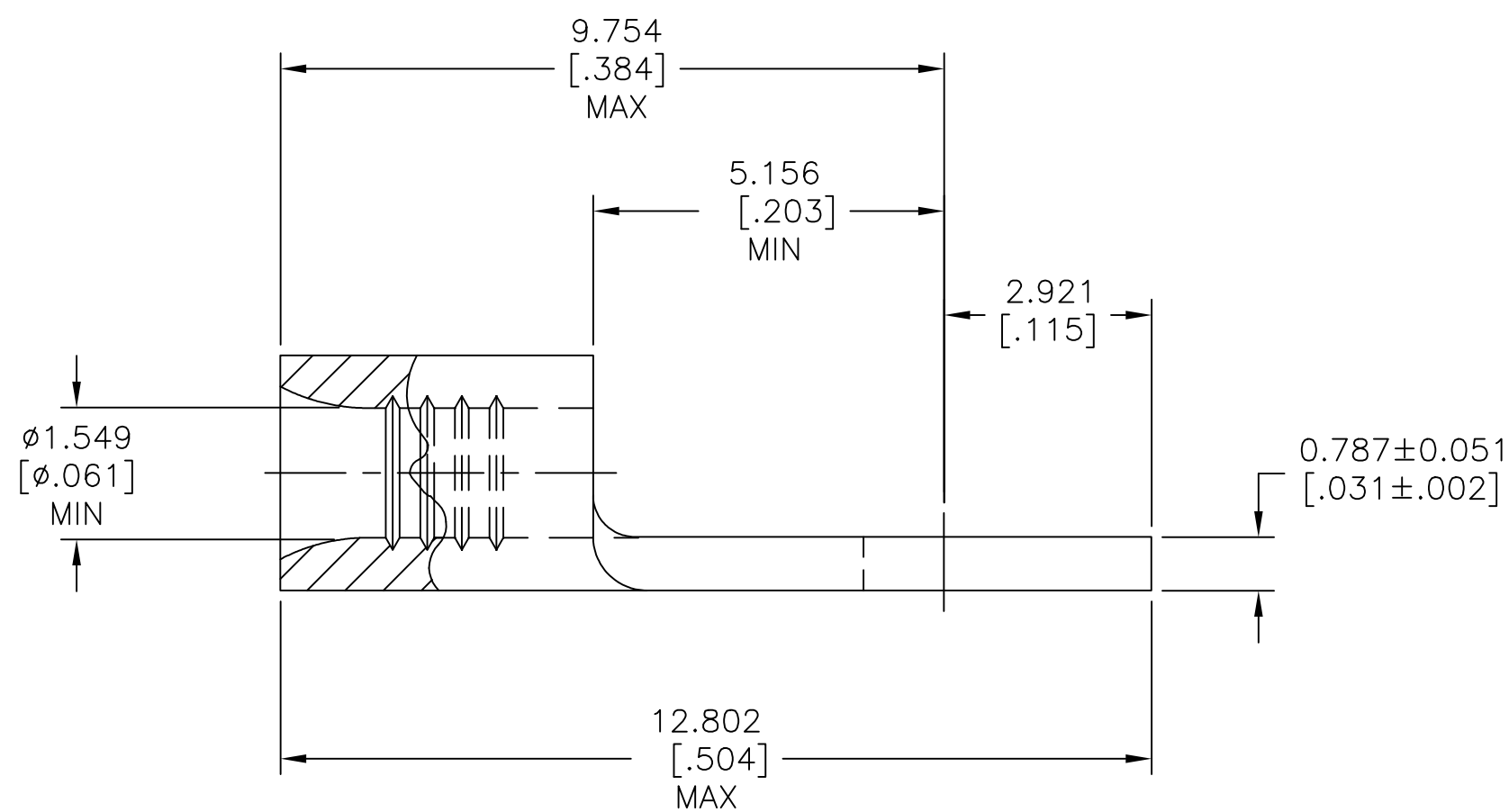

100	LOOSE PIECE, BOX	8-53555-1
1000	LOOSE PIECE	53555-1
QUANTITY	PACKAGING TYPE	PART NO

AMP INCORPORATED CUSTOMER SERVICE SYSTEMS			THIS DRAWING IS A CONTROLLED DOCUMENT.		DWN TA BRINKMAN 3-26-93	TE Connectivity Ltd.		
FOR ADDITIONAL PRODUCT INFORMATION OR COPIES OF DRAWINGS AND TECHNICAL DOCUMENTS	PRODUCT INFORMATION CENTER 1-800-522-6752	MAX RECOMMENDED OPERATING TEMPERATURE: 170°C [338°F] MAX	DIMENSIONS: mm [INCHES]	TOLERANCES UNLESS OTHERWISE SPECIFIED:	CHK DA PATTERSON 3-26-93	NAME DE MILLER		
FOR APPLICATION	TOOLING ASSISTANCE CENTER 1-800-722-1111	VOLTAGE RATING: NOT APPLICABLE		0 PLC ± - 1 PLC ± - 2 PLC ± - 3 PLC ± 0.127[.005] 4 PLC ± - ANGLES ± -	APVD DE MILLER 3-26-93	PRODUCT SPEC UL 486 A-B		
TOOLING INFORMATION	1-800-722-1111	WIRE CROSS SECTIONAL AREA RANGE, 0.26-1.65mm ² [509-3,260] CIR MILS SOLID OR STRANDED	MATERIAL COPPER PER ASTM B-152 ANNEALED	FINISH TIN PLATE 0.00254[.000100] MIN THK PER ASTM B545	APPLICATION SPEC -	SIZE A2	CAGE CODE 00779	DRAWING NO C=53555
FOR ORDER ENTRY	1-800-526-5142				WEIGHT -	RESTRICTED TO -	SCALE 10:1	SHEET 1 of 1
					CUSTOMER DRAWING	REV B1		