

FM IF detector for cordless phones

BA4116FV

The BA4116FV is an IC with mixing circuit, IF circuit, FM detector circuit, RSSI circuit, and noise detector circuit. As it can operate at low voltages, it is ideal for use in cordless phones.

●Applications

Cordless phones, amateur short wave radios, and other portable wireless equipment

●Features

- 1) Input frequencies of 10MHz to 150MHz can be accommodated.
- 2) Low-voltage operation. (1.8 to 5.5V)
- 3) Excellent temperature characteristic.
- 4) High sensitivity; 12dB SINAD sensitivity = 8dB μ VEMF (50 Ω)
- 5) High intercept point. (-11dBm)
- 6) Small package used. (0.65mm pitch)

●Absolute maximum ratings (Ta = 25°C)

Parameter	Symbol	Limits	Unit
Power supply voltage	V _{CC}	7.0	V
Power dissipation	P _d	350*	mW
Operating temperature	T _{opr}	-30~+85	°C
Storage temperature	T _{stg}	-55~+125	°C

* Reduced by 3.5mW for each increase in Ta of 1°C over 25°C.

●Recommended operating conditions (Ta = 25°C)

Parameter	Symbol	Min.	Typ.	Max.	Unit
Power supply voltage	V _{CC}	1.8	2.0	5.5	V

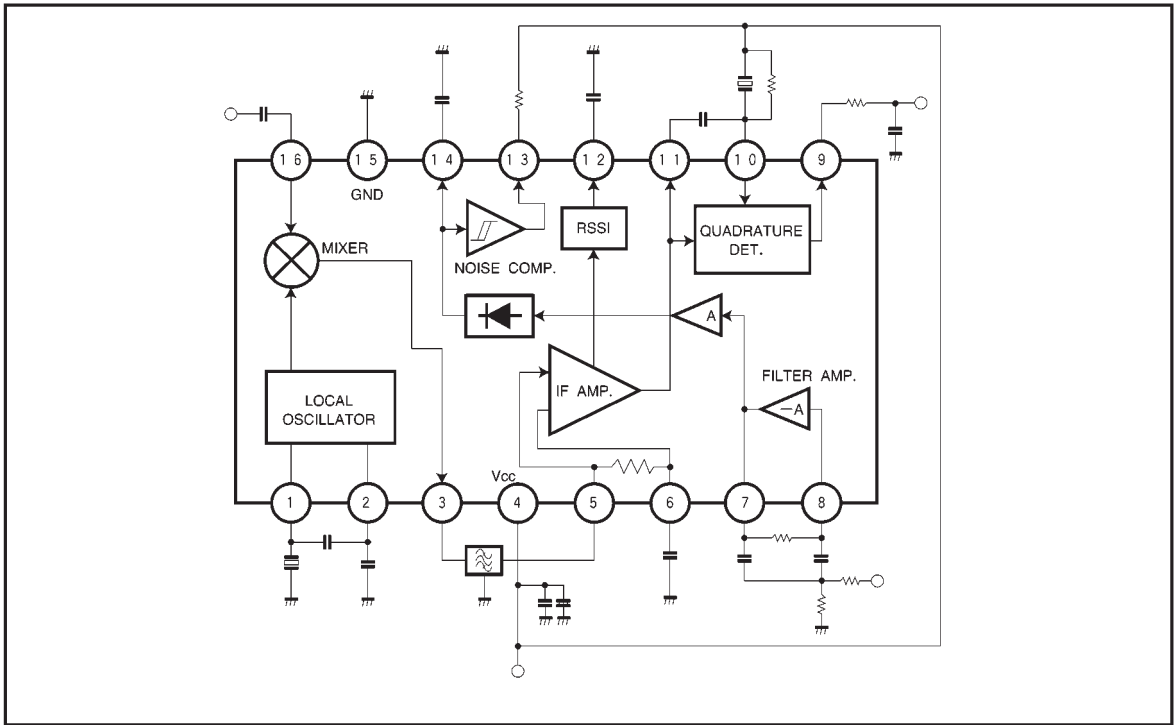

● Block diagram



● Pin descriptions

Pin No.	Function	Internal peripheral circuit	Pin voltage with no signal (V)
1	Local oscillator pin (base) Connect crystal resonator and capacitor		V_{CC}
2	Local oscillator pin (emitter) Connect capacitor or input local signal from external oscillator		$V_{CC}-0.75$
3	Mixer output pin Connect ceramic filter; output impedance is 1.8 k Ω		$V_{CC}-1.33$
4	V_{CC} pin	—	V_{CC}
5	IF amplifier input pin Connect ceramic filter; input impedance is 1.8 k Ω		$V_{CC}-0.33$
6	IF amplifier bypass pin Connect capacitor		$V_{CC}-0.33$

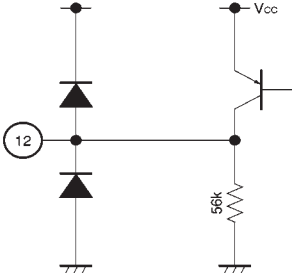
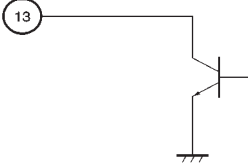
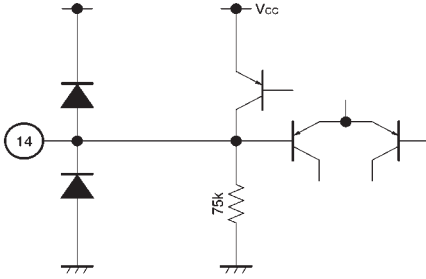
Pin No.	Function	Internal peripheral circuit	Pin voltage with no signal (V)
7	Filter amplifier output pin Connect CR network		0.70
8	Filter amplifier input pin Connect CR network		0.70
9	Demodulated signal Connect to noise amplifier or similar device; output impedance is 360 Ω		0.86
10	Discriminator pin Connect phase-shifting coil or ceramic discriminator		Vcc
11	IF amplifier output pin Connect to phase-shifting capacitor		Vcc-0.95

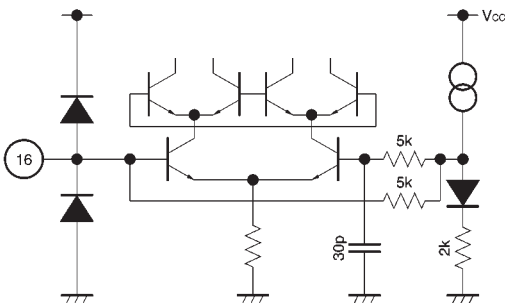
Pin No.	Function	Internal peripheral circuit	Pin voltage with no signal (V)
12	RSSI output pin Connect to capacitor		0.4
13	Noise comparator output pin Connect to load resistor		0
14	Noise detector output pin Connect to capacitor		0
15	GND pin		0
16	Mixer input pin Connect 1st IF signal from DC cut; input impedance is 5 kΩ		0.95

- Electrical characteristics (unless otherwise noted, $T_a = 25^\circ\text{C}$, $V_{CC} = 2.0\text{V}$, $f_{IN(MIX)} = 21.7\text{MHz}$, $f_{IN(IF)} = 450\text{kHz}$, $\Delta f = \pm 1.5\text{kHzdev}$, $f_m = 1\text{kHz}$, all AC levels open (EMF) display)

Parameter	Symbol	Min.	Typ.	Max.	Unit	Conditions	Measurement circuit	
Quiescent current	I_Q	2.1	3.0	4.2	mA	No input	Fig.1	
〈Mixer section〉								
Conversion gain	G_{VC}	15	18	21	dB	Tested after ceramic filter(−3 dB loss)	Fig.1	
Intercept point	I_P	—	−11	—	dBm		—	
Input impedance	R_{IN}	—	5.5	—	k Ω		—	
	C_{IN}	—	4.6	—	pF		—	
Output impedance	R_O	1.2	1.8	2.4	k Ω		—	
12 dB SINAD sensitivity	S	—	8	—	dB μV		—	
〈IF,FM detector section〉								
FM detector output	V_O	79	100	126	mVrms	$V_{IN(IF)} = 80\text{dB } \mu\text{V}$	Fig.1	
Signal-to-noise ratio	S/N	43	63	—	dB	$V_{IN(IF)} = 80\text{dB } \mu\text{V}$	Fig.1	
AM rejection ratio	AMR	—	40	—	dB	$V_{IN(IF)} = 80\text{dB } \mu\text{V}$, AM=30%	Fig.1	
Input resistance	R_{IN}	1.2	1.8	2.4	k Ω		—	
RSSI output voltage	V_{RSSI1}	0.7	1.0	1.45	V	$V_{CC}=3\text{V}$	$V_{IN(IF)} = 50\text{dB } \mu\text{V}$	Fig.1
	V_{RSSI2}	1.6	2.3	2.9	V		$V_{IN(IF)} = 100\text{dB } \mu\text{V}$	Fig.1
〈Noise detector section〉								
Output voltage	V_{NDET}	—	0.1	0.5	V	$V_{NREC}=0.2\text{V}$, $I_{SINK}=0.2\text{mA}$	Fig.1	
Output leakage current	I_{LEAK}	—	0	5	μA	$V_{NREC}=0.7\text{V}$, $V_{NDET}=2\text{V}$	Fig.1	
Noise detection high level	V_{TH-H}	0.5	0.6	0.7	V	Pin 14 voltage so that $V_{NDET} \leq 0.5\text{V}$	Fig.1	
Noise detection low level	V_{TH-L}	0.3	0.4	0.5	V	Pin 14 voltage so that $I_{SINK} \leq 5\mu\text{A}$	Fig.1	
Noise detection hysteresis width	Hys	2.0	3.5	5.0	dB	Hysteresis width between V_{TH-H} and V_{TH-L} above	Fig.1	

● Measurement circuit

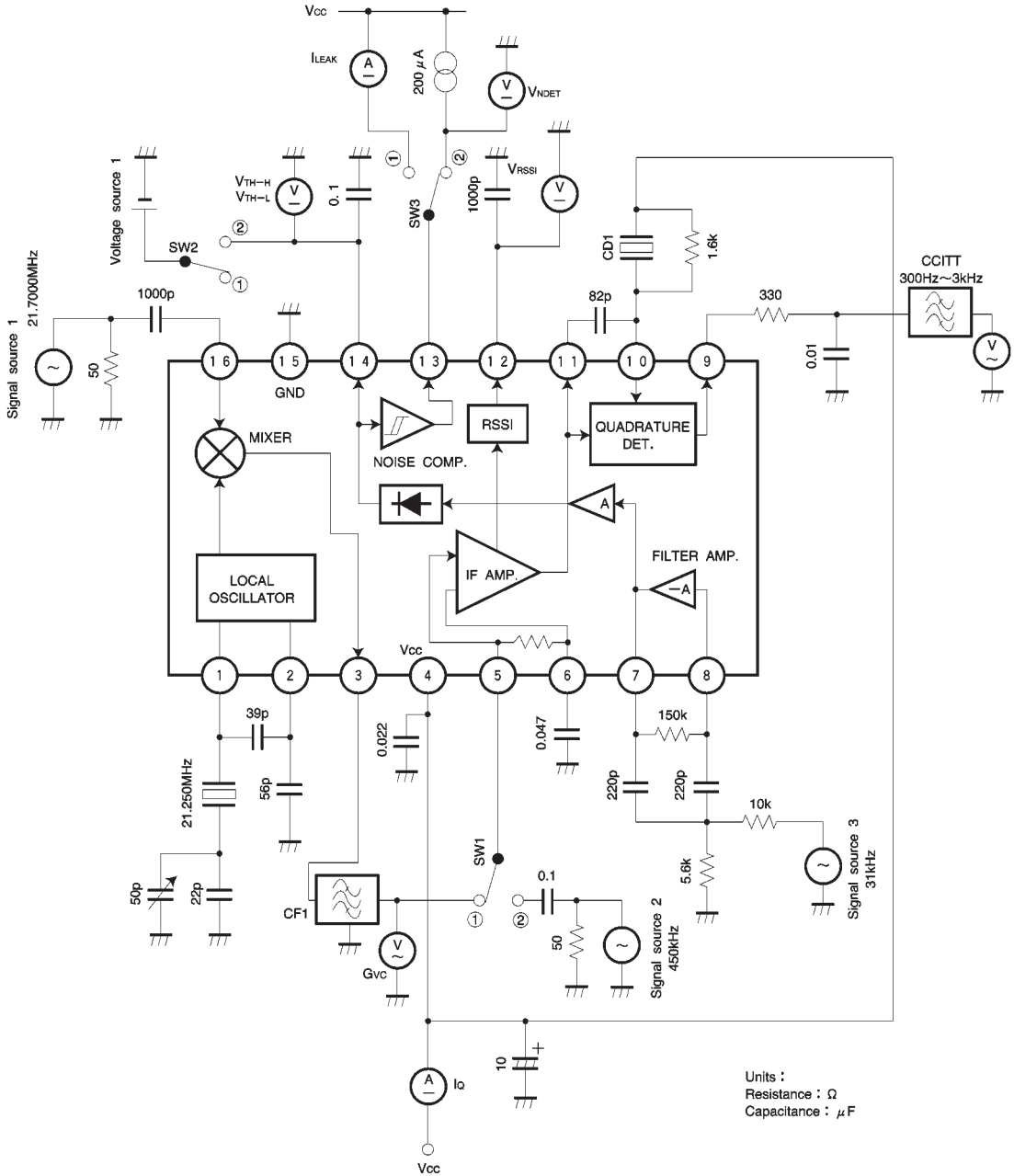

Fig. 1

●Application example

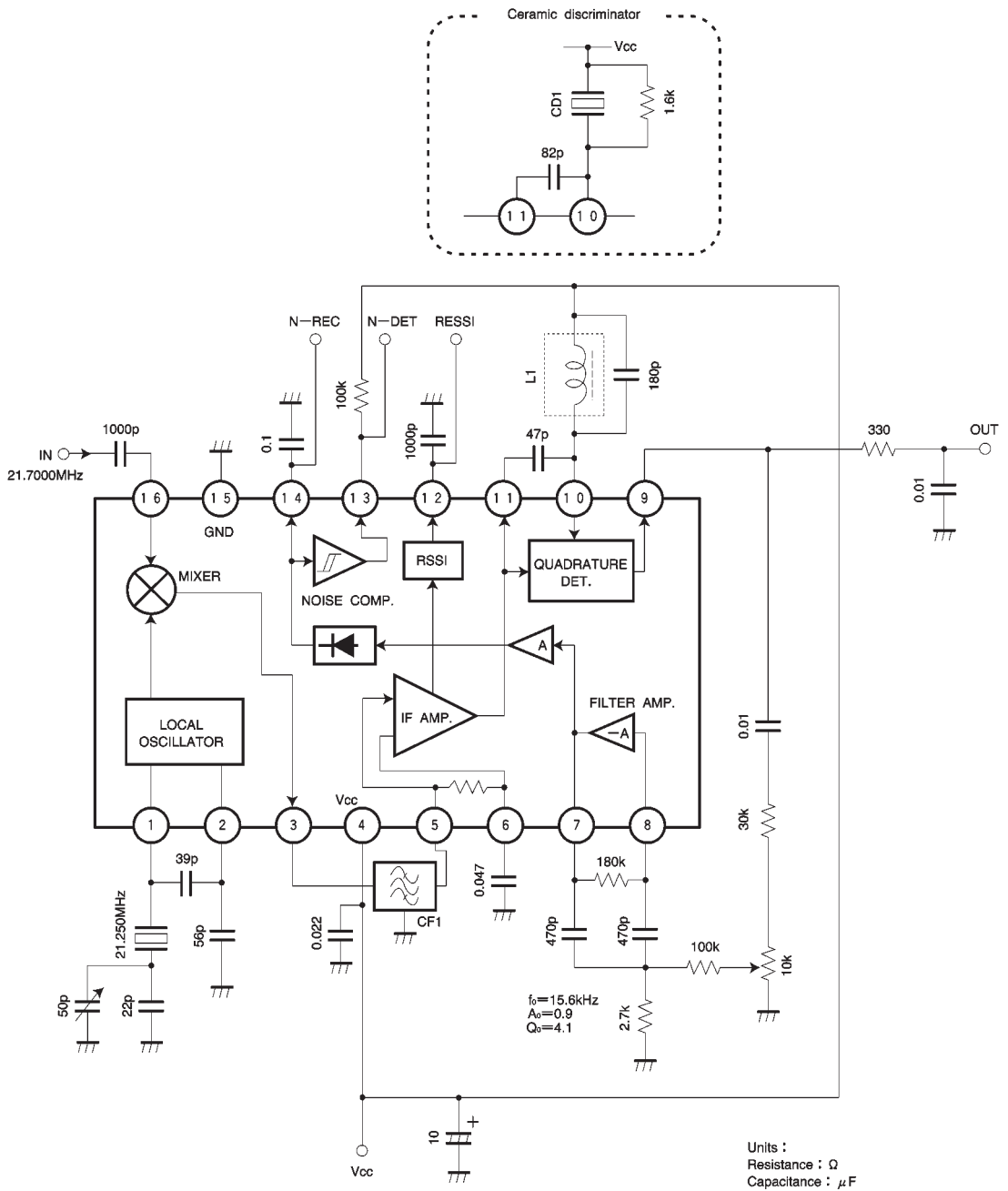
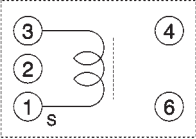

Fig. 2

●Attached components

Part No.	Part name	Prod. No./Mfg.	Notes
CF1	Ceramic filter	Murata: CFWM450G	6 dB band width = ±4.5 kHz min. Attenuation band width = ± 10 kHz max. Guaranteed attenuation= 35 dB min. Input loss = 6 dB max.
CD1	Ceramic discriminator	Murata: CDB450C24	
L1	Wave detection coil	Toko: 5PNR-2876Z	 <p>1-3 190T Wire type: 0.045ø, 3UEW</p> <p>L variable range= ±4 % Q at no load = 20 min.</p>

●Determining the filter amplifier constant (multi-layer recovery band pass filter)

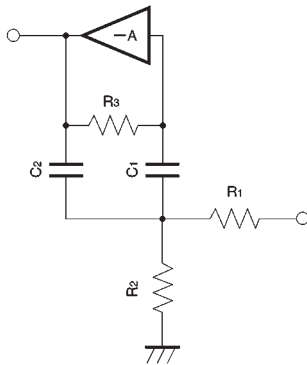

Fig. 3

f_0 : Center frequency
 Q : Center frequency f_0 /band width BW
 A_0 : I/O gain

The reference resistance R_0 is determined as $C_1 = C_2 = C_0$.
 $R_0 = 1/2\pi f_0 \cdot C_0$
 $R_1 = R_0 \cdot Q/A_0$
 $R_2 = R_0/[2Q - (A_0/Q)]$
 $R_3 = 2R_0 \cdot Q$

The Filter gain can be adjusted by varying R_1 , but with the $A_0 > 1$ design, please be aware that influence from the open loop characteristic of the amplifier causes offset in the center frequency f_0 .

●Electrical characteristic curves

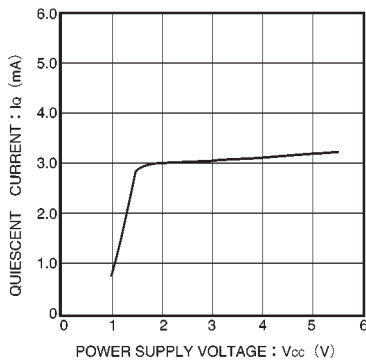

Fig. 4 Quiescent current vs. power supply voltage

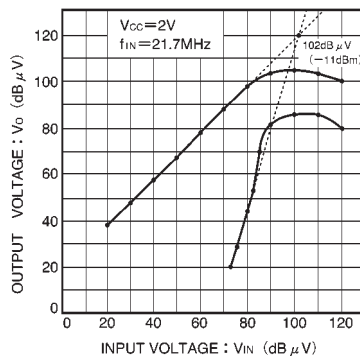

Fig. 5 Mixer output voltage vs. input voltage

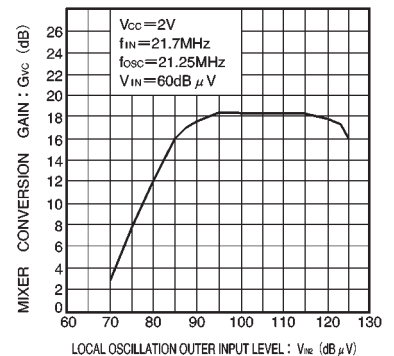

Fig. 6 Mixer conversion gain vs. Pin 2 OSC injection level

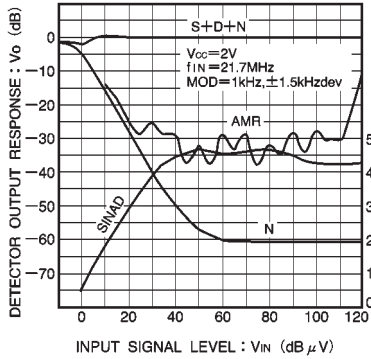

Fig. 7 Detector output response, AMR, SINAD vs. input signal level

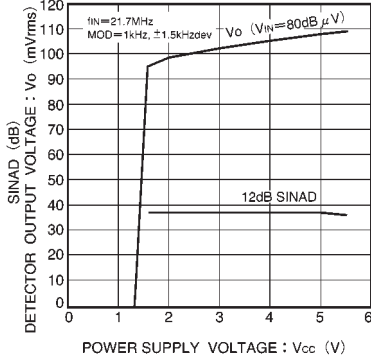

Fig. 8 Detector output voltage, 12 dB SINAD sensitivity vs. power supply voltage

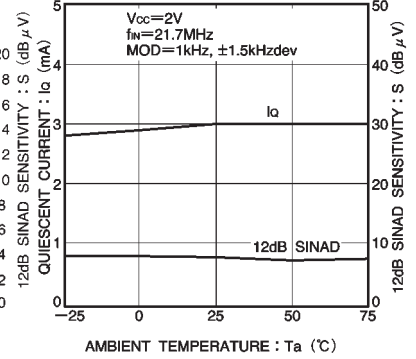

Fig. 9 Quiescent current, 12 dB SINAD sensitivity vs. ambient temperature

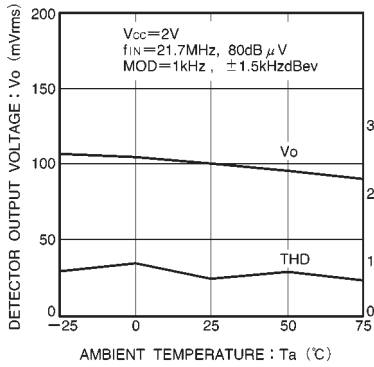

Fig. 10 Detector output level, THD vs. ambient temperature

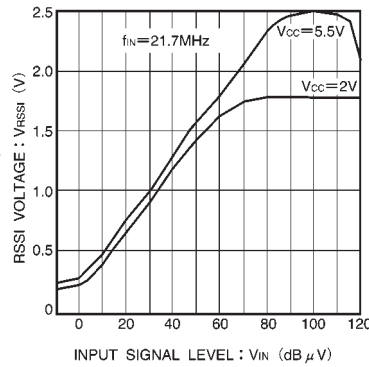

Fig. 11 RSSI voltage vs. input signal level

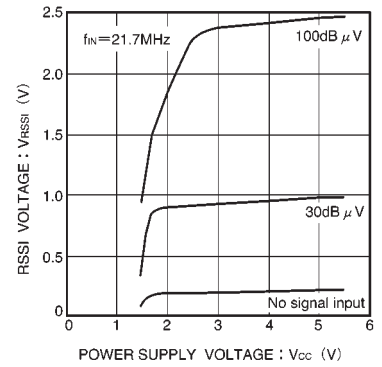

Fig. 12 RSSI voltage vs. power supply voltage

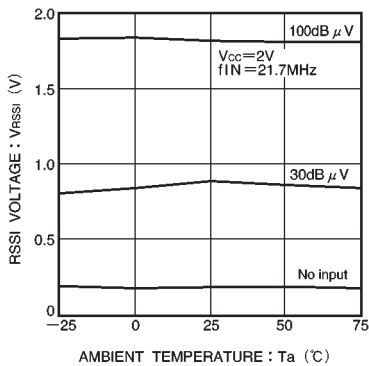

Fig. 13 RSSI voltage vs. ambient temperature

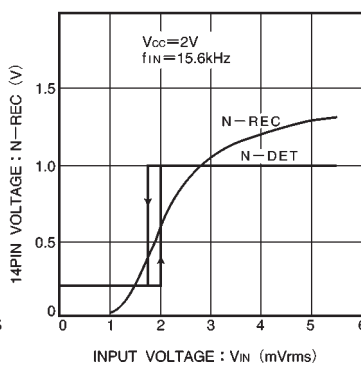

Fig. 14 Pin 13 voltage, Pin 14 voltage vs. noise amplifier input voltage

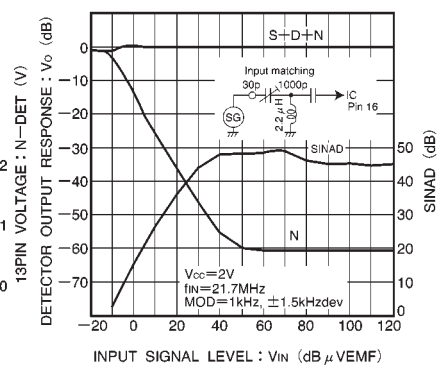
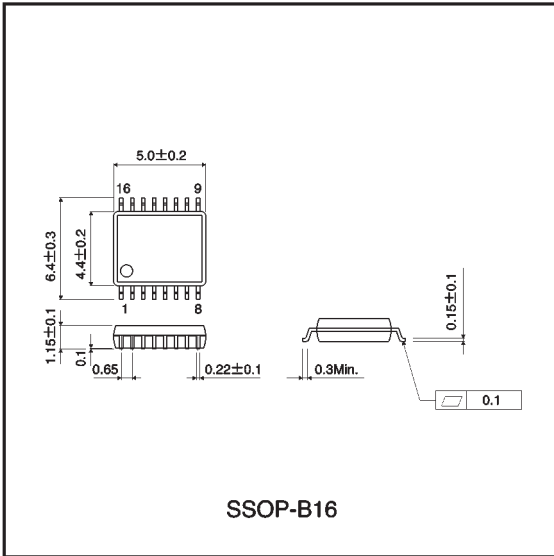

Fig. 15 Detector output response, SINAD vs. input signal level

● External dimensions (Units: mm)



Notes

- No technical content pages of this document may be reproduced in any form or transmitted by any means without prior permission of ROHM CO.,LTD.
- The contents described herein are subject to change without notice. The specifications for the product described in this document are for reference only. Upon actual use, therefore, please request that specifications to be separately delivered.
- Application circuit diagrams and circuit constants contained herein are shown as examples of standard use and operation. Please pay careful attention to the peripheral conditions when designing circuits and deciding upon circuit constants in the set.
- Any data, including, but not limited to application circuit diagrams information, described herein are intended only as illustrations of such devices and not as the specifications for such devices. ROHM CO.,LTD. disclaims any warranty that any use of such devices shall be free from infringement of any third party's intellectual property rights or other proprietary rights, and further, assumes no liability of whatsoever nature in the event of any such infringement, or arising from or connected with or related to the use of such devices.
- Upon the sale of any such devices, other than for buyer's right to use such devices itself, resell or otherwise dispose of the same, no express or implied right or license to practice or commercially exploit any intellectual property rights or other proprietary rights owned or controlled by
- ROHM CO., LTD. is granted to any such buyer.
- Products listed in this document use silicon as a basic material.
Products listed in this document are no antiradiation design.

The products listed in this document are designed to be used with ordinary electronic equipment or devices (such as audio visual equipment, office-automation equipment, communications devices, electrical appliances and electronic toys).

Should you intend to use these products with equipment or devices which require an extremely high level of reliability and the malfunction of which would directly endanger human life (such as medical instruments, transportation equipment, aerospace machinery, nuclear-reactor controllers, fuel controllers and other safety devices), please be sure to consult with our sales representative in advance.

About Export Control Order in Japan

Products described herein are the objects of controlled goods in Annex 1 (Item 16) of Export Trade Control Order in Japan.

In case of export from Japan, please confirm if it applies to "objective" criteria or an "informed" (by MITI clause) on the basis of "catch all controls for Non-Proliferation of Weapons of Mass Destruction.

Mouser Electronics

Authorized Distributor

Click to View Pricing, Inventory, Delivery & Lifecycle Information:

[ROHM Semiconductor:](#)

[BA4116FV-E2](#)