

PART NUMBER	C THREAD CLASS 2B	E DIA ±.005	K DIA MAX	R +.000 -.010	T THREAD CLASS 2A	RELEASE	MADE FROM
10-123011-6	.3125-32 UNEF	.190	.469	.215	.3750-32 UNEF	31508-287	10-123011-6B
-8	.4375-28 UNEF	.312	.594		.5000-28 UNEF		-8B
-10	.5625-24 UNEF	.436	.719		.6250-24 UNEF		-10B
-12	.6875-24 UNEF	.561	.844		.7500-20 UNEF		-12B
-14	.8125-20 UNEF	.678	.969		.8750-20 UNEF		-14B
-16	.9375-20 UNEF	.802	1.094		1.0000-20 UNEF		-16B
-18	1.0625-18 UNEF	.894	1.219		1.1875-18 UNEF		-18B
-20	1.1875-18 UNEF	1.029	1.312	.312	1.1875-18 UNEF		-20B
-22	1.3125-18 UNEF	1.150	1.469		1.4375-18 UNEF		-22B
-24	1.4375-18 UNEF	1.274	1.594		1.4375-18 UNEF	33524-599	-24B

REL NO. 31508-287		REVISIONS			
CHG NO.	SYM	DESCRIPTION	DATE	APPROVED	
43525-746	A1	REDRAWN, WAS SIZE "B" TYPE WRITTEN; PROVIDED ENVELOPE DWG	11-21-64	W. GAY	
47524-170	A2	ADD & REL -XX9 FINISH	11-16-65	W. GAY	
55524-58	A3	ADD & REL -XXG FINISH	11-16-65	W. GAY	
72024-54	B	(CLII) ADD & REL -XX7 FINISH	5/12/81	WILKINSON	
76484-1	C	(CLII) ADDED MADE FROM COLUMN	11-2-65	WILKINSON	
80444-1	D	(CLII) ADD & REL -XX8 FINISH TO NOTE 1	9-1-69	WILKINSON	
82906	E	(CLII) ADD & REL -XXY FINISH	3-5-97	JED	
85035	F	ADD AND REL -XXX FINISH TO COLUMN	11/10/83	JED	
85448	G	(CLII) SEE ECN: 85448	4-27-99	JED	
86546	H	(CLII) ADD & RELEASE -XXU FINISH & DATA	4-28-99	JED	

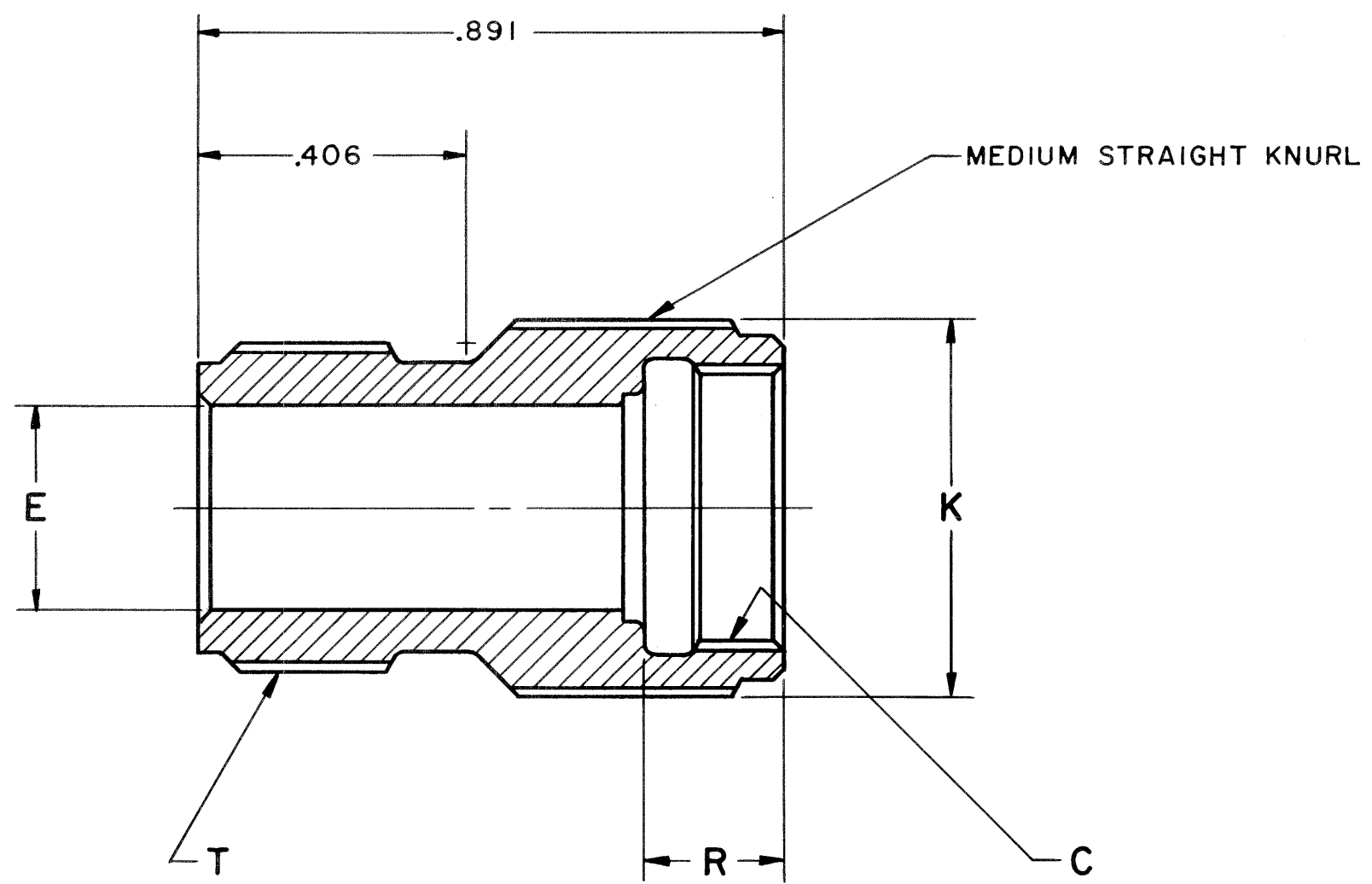

USE OF THIS DOCUMENT IS UNLIMITED. DOCUMENTS REFERENCED HEREON CONTAIN LIMITED RIGHTS DATA.

3. REF SYMBOL

2. THREADS ARE IN ACCORDANCE WITH FEDERAL HANDBOOK H-28.

1. TO COMPLETE PART NO., ADD APPLICABLE LAST DIGIT TO SUFFIX FOR DESIRED FINISH.

CHROMATE TREAT	SUFFIX -XX0
CADMIUM PLATE	SUFFIX -XX1
BLACK ANODIZE	SUFFIX -XX2
CADMIUM PLATE OLIVE DRAB	SUFFIX -XX3
GREY ANODIZE	SUFFIX -XX4
ANODIC COATING	SUFFIX -XX5
BRIGHT CADMIUM PLATE, NICKEL BASE	SUFFIX -XX7
NICKEL ALLOY PLATE	SUFFIX -XXG
CAD PLATE, O.D. NICKEL BASE	SUFFIX -XX9
BRIGHT NICKEL	SUFFIX -XX8
BLACK ZINC ALLOY PLATE	SUFFIX -XXY
BLACK ZINC CONDUCTIVE	SUFFIX -XXX

RELEASE NO.	
38524-872	9-3350 GREEN ZINC
35524-218	9-2158 ALLOY PLATE
35524-218	9-3487 SUFFIX-XXU 9-9263
32525-260	9-3047
31508-287	9-3487
35508-72	9-3290
55524-58	9-4332
47524-170	9-6914
42524-249	9-4960
	9-3435
	9-9181
	9-9181-1

ITEM NO.	QTY REQD	DESCRIPTION	PART NUMBER	CODE IDENT	ZONE
PARTS LIST					
UNLESS OTHERWISE SPECIFIED					
LINEAR DIMENSIONS ARE IN INCHES. TOLERANCES: 3 PLACES ±.010; 2 PLACES ±.03; 1 PLACE ±.1; ANGLES ±2°. OTHER STANDARDS PER SCINTILLA SPEC 9-3800 AND MIL-STD 8.					
MATERIAL SPEC ALUMINUM ALLOY		PROCESS SPEC	DRAWN: HAYES DATE: 7-12-56 CHECKED: Teelon DATE: 4-7-65 MATERIAL: STANDARDS: J. Balantini 4-7-65 DRAFTING: D Sweet 4-7-65 ENGINEERING: W. G. Harrison 4-7-65 DEVELOPMENT:		
SCINTILLA DIVISION CORPORATION SIDNEY, NEW YORK, U.S.A.					
ADAPTER, ELECTRICAL CONNECTOR, TYPE PB(), (ENVELOPE DRAWING)					
CODE IDENT NO. 77820		SIZE C	10-123011		
SCALE NONE	WT	REF	SHEET		

10-123011

Mouser Electronics

Authorized Distributor

Click to View Pricing, Inventory, Delivery & Lifecycle Information:

Amphenol:

[10-123011-183](#) [10-123011-08G](#) [10-123011-18G](#) [10-123011-20G](#) [10-123011-081](#) [10-123011-083](#) [10-123011-103](#)
[10-123011-105](#) [10-123011-10G](#) [10-123011-123](#) [10-123011-125](#) [10-123011-12G](#) [10-123011-143](#) [10-123011-14G](#)
[10-123011-163](#) [10-123011-16G](#) [10-123011-203](#) [10-123011-223](#) [10-123011-22G](#) [10-123011-145](#) [10-123011-16Y](#)
[10-123011-122](#) [10-123011-165](#) [10-123011-085](#) [10-123011-243](#) [10-123011-20X](#) [10-123011-10X](#) [10-123011-185](#) [10-](#)
[123011-225](#) [10-123011-20Y](#) [10-123011-141](#) [10-123011-181](#) [10-123011-16X](#) [10-123011-12X](#) [10-123011-12Y](#) [10-](#)
[123011-08X](#) [10-123011-14X](#) [10-123011-18X](#) [10-123011-22X](#) [10-123011-14Y](#) [10-123011-10Y](#) [10-123011-121](#)