

Sensorless Motor Control IC for Appliances

Features

- **MCE™ (Motion Control Engine) - Hardware based computation engine for high efficiency sinusoidal sensorless control of permanent magnet AC motor**
- **Supports both interior and surface permanent magnet motors**
- **Built-in hardware peripheral for single shunt current feedback reconstruction**
- **No external current or voltage sensing operational amplifier required**
- **Three/two-phase Space Vector PWM**
- **Analog output (PWM)**
- **Embedded 8-bit high speed microcontroller (8051) for flexible I/O and man-machine control**
- **JTAG programming port for emulation/debugger**
- **Serial communication interface (UART)**
- **I²C/SPI serial interface**
- **Watchdog timer with independent analog clock**
- **Three general purpose timers/counters**
- **Two special timers: periodic timer, capture timer**
- **External EEPROM and internal RAM facilitate debugging and code development**
- **Pin compatible with IRMCK371, OTP-ROM version**
- **1.8V/3.3V CMOS**

Product Summary

Maximum crystal frequency	60 MHz
Maximum internal clock (SYSCLK) frequency	128 MHz
Sensorless control computation time	11 µsec typ
MCE™ computation data range	16 bit signed
Program RAM loaded from external EEPROM	48K bytes
Data RAM	8K bytes
GateKill latency (digital filtered)	2 µsec
PWM carrier frequency counter	16 bits/ SYSCLK
A/D input channels	4
A/D converter resolution	12 bits
A/D converter conversion speed	2 µsec
8051 instruction execution speed	2 SYSCLK
Analog output (PWM) resolution	8 bits
UART baud rate (typ)	57.6K bps
Number of I/O (max)	13
Package (lead-free)	QFP48

Description

IRMCF371 is a high performance RAM based motion control IC designed primarily for appliance applications. IRMCF371 is designed to achieve low cost and high performance control solutions for advanced inverterized appliance motor control. IRMCF371 contains two computation engines. One is Motion Control Engine (MCE™) for sensorless control of permanent magnet motors; the other is an 8-bit high-speed microcontroller (8051). Both computation engines are integrated into one monolithic chip. The MCE™ contains a collection of control elements such as Proportional plus Integral, Vector rotator, Angle estimator, Multiply/Divide, Low loss SVPWM, Single Shunt IFB. The user can program a motion control algorithm by connecting these control elements using a graphic compiler. Key components of the sensorless control algorithms, such as the Angle Estimator, are provided as complete pre-defined control blocks implemented in hardware. A unique analog/digital circuit and algorithm to fully support single shunt current reconstruction is also provided. The 8051 microcontroller performs 2-cycle instruction execution (60MIPS at 120MHz). The MCE and 8051 microcontroller are connected via dual port RAM to process signal monitoring and command input. An advanced graphic compiler for the MCE™ is seamlessly integrated into the MATLAB/Simulink environment, while third party JTAG based emulator tools are supported for 8051 developments. IRMCF371 comes with a small QFP48 pin lead-free package.

TABLE OF CONTENTS

1	Overview	4
2	IRMCF371 Block Diagram and Main Functions	5
3	Pinout	7
4	Input/Output of IRMCF371	8
4.1	8051 Peripheral Interface Group	8
4.2	Motion Peripheral Interface Group	9
4.3	Analog Interface Group	9
4.4	Power Interface Group	10
4.5	Test Interface Group	10
5	Application Connections	11
6	DC Characteristics	12
6.1	Absolute Maximum Ratings	12
6.2	System Clock Frequency and Power Consumption	12
6.3	Digital I/O DC Characteristics	13
6.4	PLL and Oscillator DC characteristics	14
6.5	Analog I/O DC Characteristics	14
6.6	Under Voltage Lockout DC characteristics	15
6.7	CMEXT and AREF Characteristics	15
7	AC Characteristics	16
7.1	PLL AC Characteristics	16
7.2	Analog to Digital Converter AC Characteristics	17
7.3	Op Amp AC Characteristics	17
7.4	SYNC to SVPWM and A/D Conversion AC Timing	18
7.5	GATEKILL to SVPWM AC Timing	19
7.6	Interrupt AC Timing	20
7.7	I ² C AC Timing	21
7.8	SPI AC Timing	22
7.8.1	SPI Write AC timing	22
7.8.2	SPI Read AC Timing	23
7.9	UART AC Timing	24
7.10	CAPTURE Input AC Timing	25
7.11	JTAG AC Timing	26
8	Pin List	27
9	Package Dimensions	29
10	Part Marking Information	30

TABLE OF FIGURES

Figure 1.	Typical Application Block Diagram Using IRMCF371	4
Figure 2.	IRMCF371 Internal Block Diagram	5
Figure 3.	IRMCF371 Pin Configuration	7
Figure 4.	Input/Output of IRMCF371	8
Figure 5.	Application Connection of IRMCF371	11
Figure 6.	Clock Frequency vs. Power Consumption	12

TABLE OF TABLES

Table 1.	Absolute Maximum Ratings	12
Table 2.	System Clock Frequency	12
Table 3.	Digital I/O DC Characteristics	13
Table 4.	PLL DC Characteristics	14
Table 5.	Analog I/O DC Characteristics	14
Table 6.	UVcc DC Characteristics	15
Table 7.	CMEXT and AREF DC Characteristics	15
Table 8.	PLL AC Characteristics	16
Table 9.	A/D Converter AC Characteristics	17
Table 10.	Current Sensing OP amp Amp AC Characteristics	17
Table 11.	SYNC AC Characteristics	18
Table 12.	GATEKILL to SVPWM AC Timing	19
Table 13.	Interrupt AC Timing	20
Table 14.	I ² C AC Timing	21
Table 15.	SPI Write AC Timing	22
Table 16.	SPI Read AC Timing	23
Table 17.	UART AC Timing	24
Table 18.	CAPTURE AC Timing	25
Table 19.	JTAG AC Timing	26
Table 20.	Pin List	28

1 Overview

IRMCF371 is a new International Rectifier integrated circuit device primarily designed as a one-chip solution for complete inverter controlled appliance motor control applications. Unlike a traditional microcontroller or DSP, the IRMCF371 provides a built-in closed loop sensorless control algorithm using the unique Motion Control Engine (MCE™) for permanent magnet motors. The MCE™ consists of a collection of control elements, motion peripherals, a dedicated motion control sequencer and dual port RAM to map internal signal nodes. IRMCF371 also employs a unique single shunt current reconstruction circuit to eliminate additional analog/digital circuitry and enables a direct shunt resistor interface to the IC. Motion control programming is achieved using a dedicated graphical compiler integrated into the MATLAB/Simulink™ development environment. Sequencing, user interface, host communication, and upper layer control tasks can be implemented in the 8051 high-speed 8-bit microcontroller. The 8051 microcontroller is equipped with a JTAG port to facilitate emulation and debugging tools. Figure 1 shows a typical application schematic using the IRMCF371.

IRMCF371 is intended for development purpose and contains 48K bytes of RAM, which can be loaded from external EEPROM for 8051 program execution. For high volume production, IRMCK371 contains OTP ROM in place of program RAM to reduce the cost. Both IRMCF371 and IRMCK371 come in the same 48-pin QFP package with identical pin configuration to facilitate PC board layout and transition to mass production

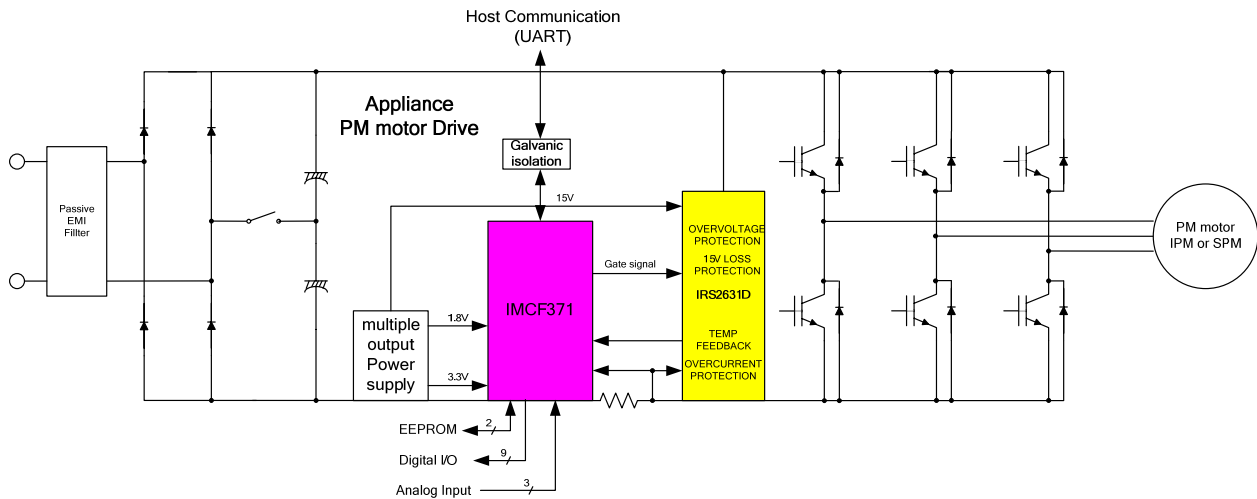

Figure 1. Typical Application Block Diagram Using IRMCF371

2 IRMCF371 Block Diagram and Main Functions

IRMCF371 block diagram is shown in Figure 2.

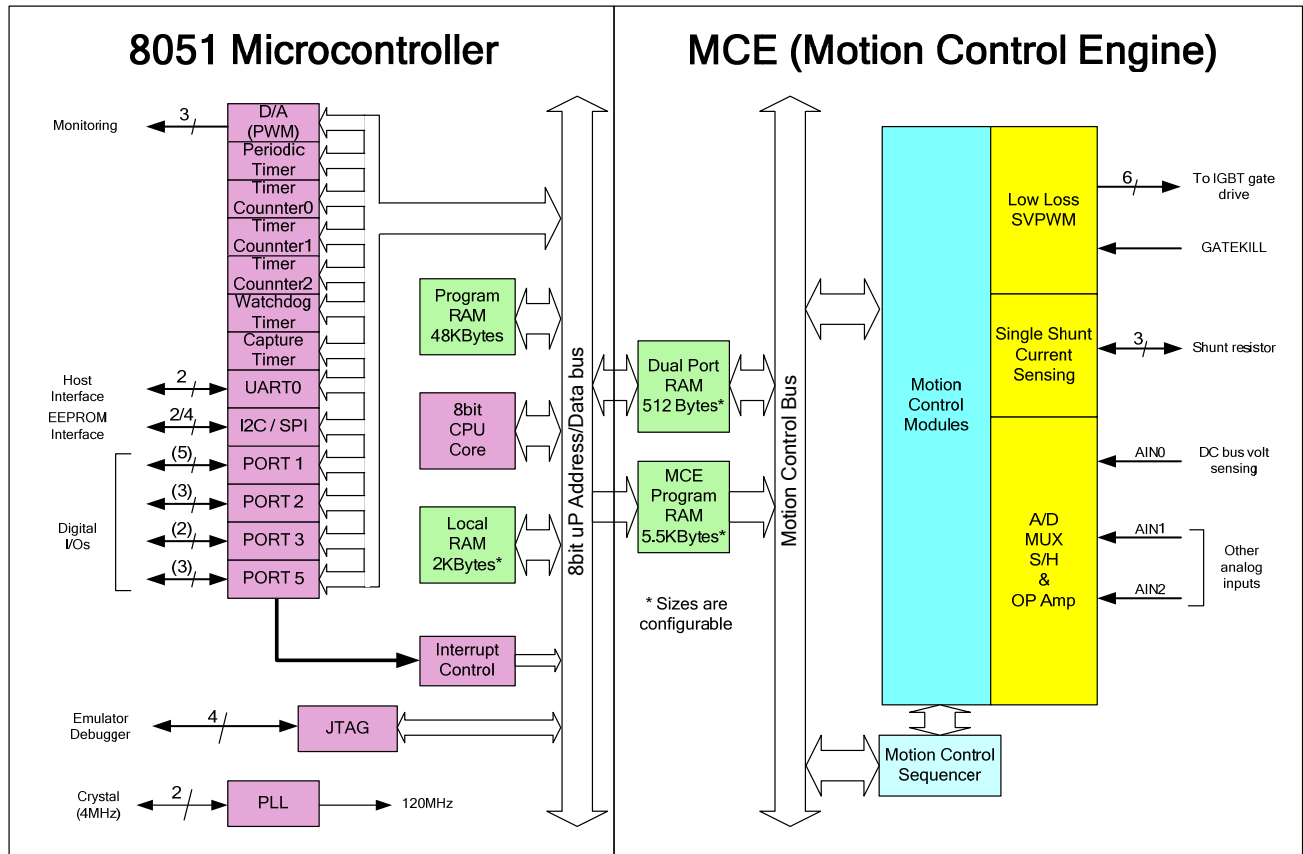

Figure 2. IRMCF371 Internal Block Diagram

IRMCF371 contains the following functions for sensorless AC motor control applications:

- Motion Control Engine (MCE™)
 - Proportional plus Integral block
 - Low pass filter
 - Differentiator and lag (high pass filter)
 - Ramp
 - Limit
 - Angle estimate (sensorless control)
 - Inverse Clark transformation
 - Vector rotator
 - Bit latch
 - Peak detect

- Transition
 - Multiply-divide (signed and unsigned)
 - Divide (signed and unsigned)
 - Adder
 - Subtractor
 - Comparator
 - Counter
 - Accumulator
 - Switch
 - Shift
 - ATAN (arc tangent)
 - Function block (any curve fitting, nonlinear function)
 - 16-bit wide Logic operations (AND, OR, XOR, NOT, NEGATE)
 - MCE™ program and data memory (6K byte). ^{Note 1}
 - MCE™ control sequencer
- 8051 microcontroller
 - Three 16-bit timer/counters
 - 16-bit periodic timer
 - 16-bit analog watchdog timer
 - 16-bit capture timer
 - Up to 13 discrete I/Os
 - Four-channel 12-bit A/D
 - One buffered channel for current sensing (0 – 1.2V input)
 - Three unbuffered channels (0 – 1.2V input)
 - JTAG port (4 pins)
 - One channel of analog output (8-bit PWM)
 - UART
 - I²C/SPI port
 - 48K byte program RAM loaded from external EEPROM
 - 2K byte data RAM. ^{Note 1}

Note 1: Total size of RAM is 8K byte including MCE program, MCE data, and 8051 data. Different sizes can be allocated depending on applications.

3 Pinout

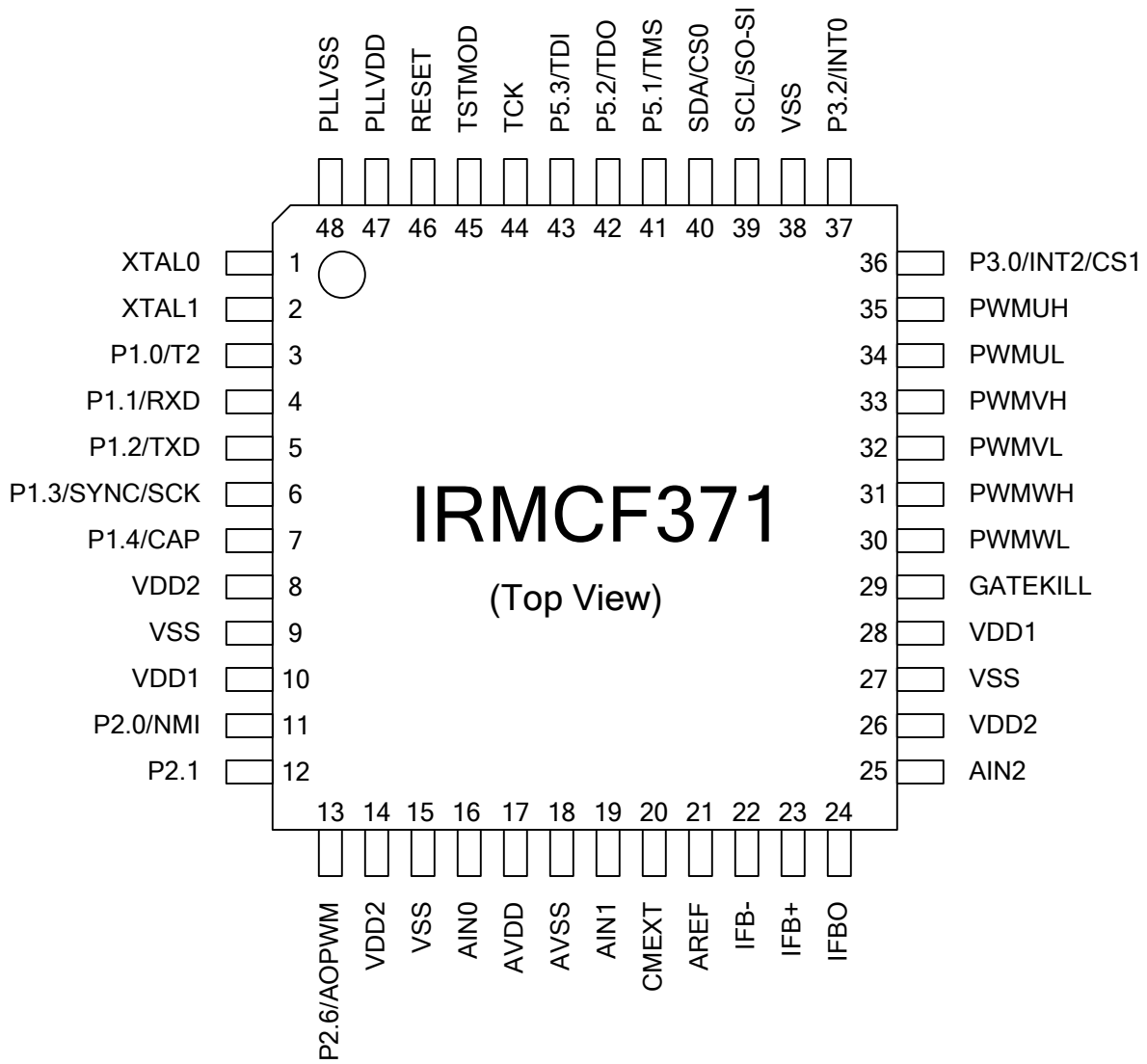

Figure 3. IRMCF371 Pin Configuration

4 Input/Output of IRMCF371

All I/O signals of IRMCF371 are shown in Figure 4. All I/O pins are 3.3V logic interface except A/D interface pins.

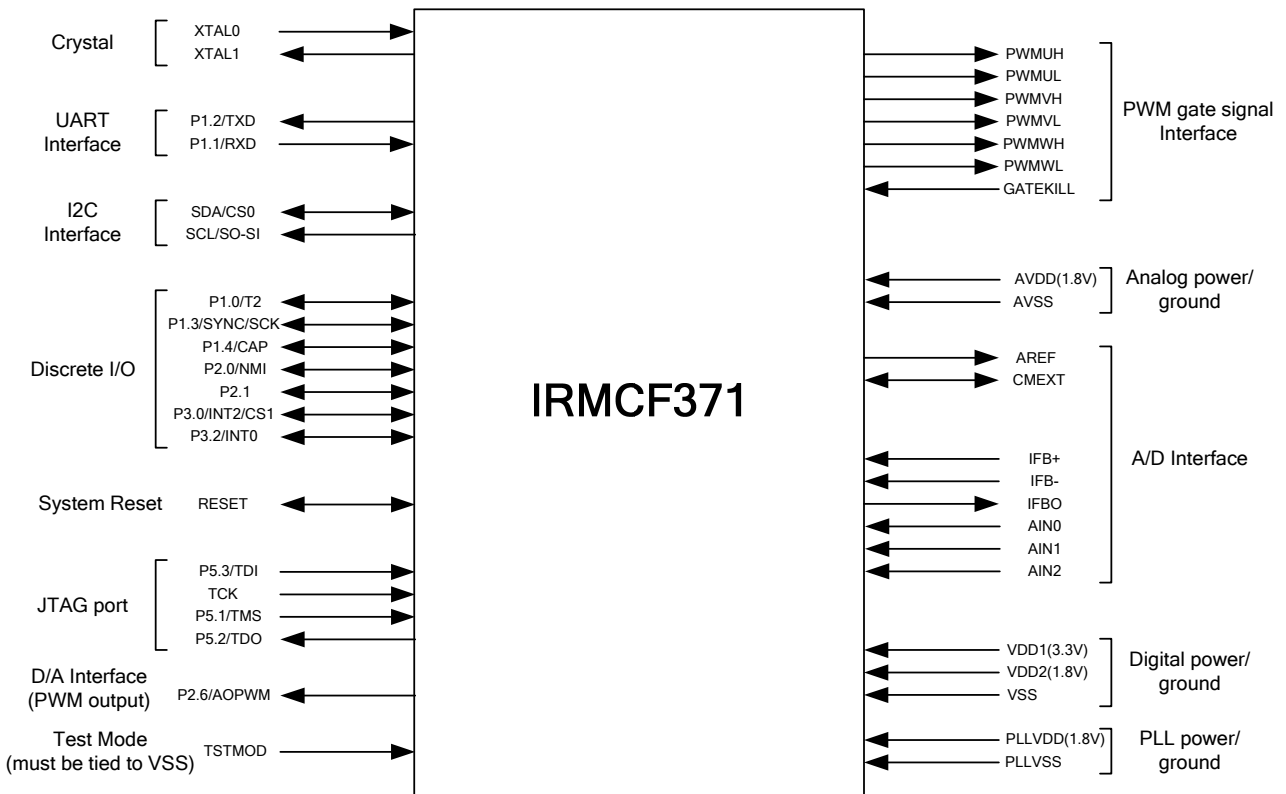

Figure 4. Input/Output of IRMCF371

4.1 8051 Peripheral Interface Group

UART Interface

P1.2/TXD Output, Transmit data from IRMCF371, can be configured as P1.2
 P1.1/RXD Input, Receive data to IRMCF371, can be configured as P1.1

Discrete I/O Interface

P1.0/T2 Input/output port 1.0, can be configured as Timer 2 input
 P1.1/RXD Input/output port 1.1, can be configured as RXD input
 P1.2/TXD Input/output port 1.2, can be configured as TXD output
 P1.3/SYNC/SCK Input/output port 1.3, can be configured as SYNC output or SPI clock, needs to be pulled up to VDD1 in order to boot from I²C EEPROM
 P1.4/CAP Input/output port 1.4, can be configured as Capture Timer input
 P2.0/NMI Input/output port 2.0, can be configured as non-maskable interrupt input
 P2.1 Input/output port 2.1

P3.0/INT2/CS1	Input/output port 3.0, can be configured as INT2 input or SPI chip select 1
P3.2/INT0	Input/output port 3.2, can be configured as INT0 input

Analog Output Interface

AOPWM	Output, PWM output 0, 8-bit resolution, configurable carrier frequency
-------	--

Crystal Interface

XTAL0	Input, connected to crystal
XTAL1	Output, connected to crystal

Reset Interface

RESET	Inout, system reset, needs to be pulled up to VDD1 but doesn't require external RC time constant
-------	--

I²C/SPI Interface

SCL/SO-SI	Input/output, I ² C clock output or SPI data
SDA/CS0	Input/output, I ² C Data line or SPI chip select 0
P3.0/INT2/CS1	Input/output, INT2 or SPI chip select 1
P1.3/SYNC/SCK	Input/output, SYNC output or SPI clock, needs to be pulled up to VDD1 in order to boot from I ² C EEPROM

4.2 Motion Peripheral Interface Group

PWM

PWMUH	Output, PWM phase U high side gate signal
PWMUL	Output, PWM phase U low side gate signal
PWMVH	Output, PWM phase V high side gate signal
PWMVL	Output, PWM phase V low side gate signal
PWMWH	Output, PWM phase W high side gate signal
PWMWL	Output, PWM phase W low side gate signal

Fault

GATEKILL	Input, upon assertion, this negates all six PWM signals, programmable logic sense
----------	---

4.3 Analog Interface Group

AVDD	Analog power (1.8V)
AVSS	Analog power return
AREF	0.6V buffered output
CMEXT	Unbuffered 0.6V, input to the AREF buffer, capacitor needs to be connected.
IFB+	Input, Operational amplifier positive input for shunt resistor current sensing
IFB-	Input, Operational amplifier negative input for shunt resistor current sensing
IFBO	Output, Operational amplifier output for shunt resistor current sensing

AIN0	Input, Analog input channel 0 (0 – 1.2V), typically configured for DC bus voltage input
AIN1	Input, Analog input channel 1 (0 – 1.2V), needs to be pulled down to AVSS if unused
AIN2	Input, Analog input channel 2 (0 – 1.2V), needs to be pulled down to AVSS if unused

4.4 Power Interface Group

VDD1	Digital power for I/O (3.3V)
VDD2	Digital power for core logic (1.8V)
VSS	Digital common
PLLVDD	PLL power (1.8V)
PLLVSS	PLL ground return

4.5 Test Interface Group

TSTMOD	Must be tied to VSS, used only for factory testing.
P5.1/TSM	Input/output port 5.1, configured as JTAG port by default
P5.2/TDO	Input/output port 5.2, configured as JTAG port by default
P5.3/TDI	Input/output port 5.3, configured as JTAG port by default
TCK	Input, JTAG test clock

5 Application Connections

Typical application connection is shown in Figure 5. All components necessary to implement a complete sensorless drive control algorithm are shown connected to IRMCF371.

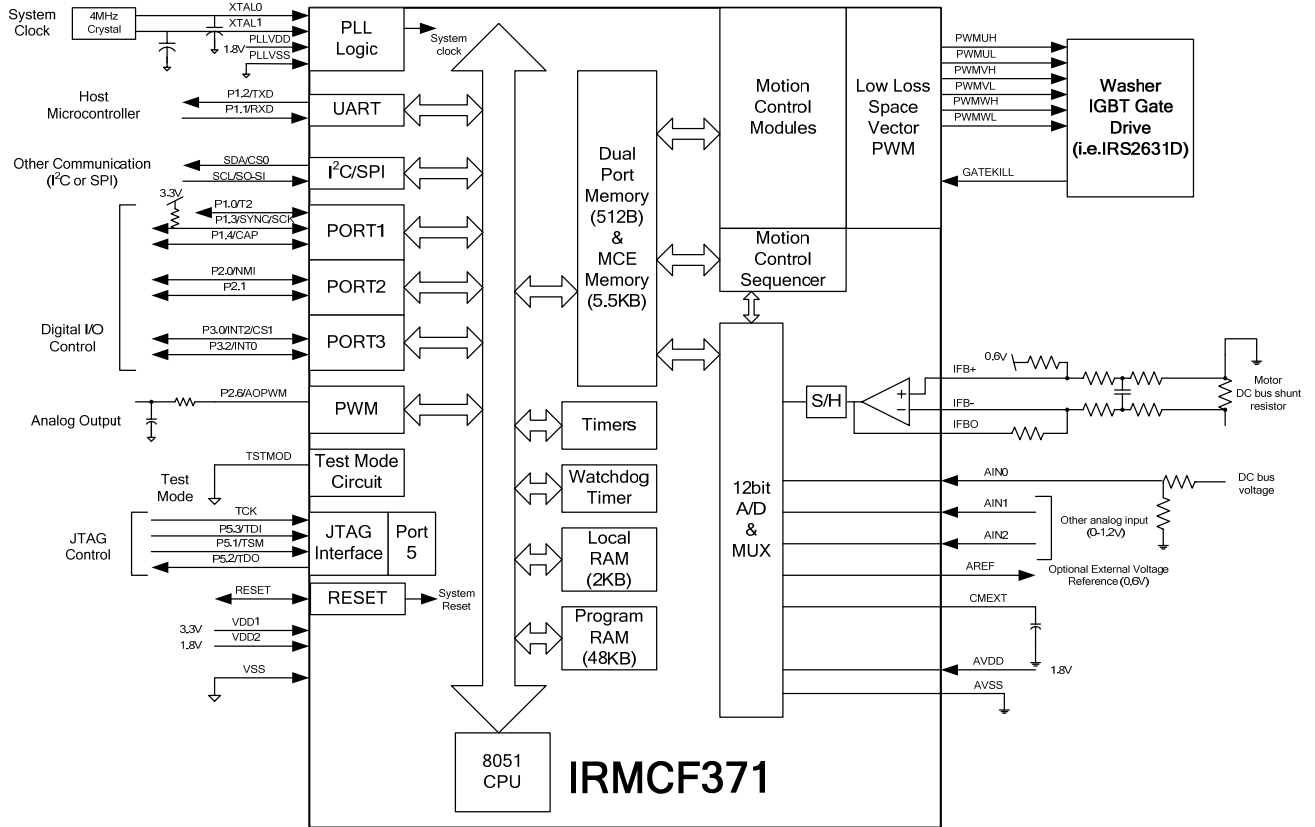

Figure 5. Application Connection of IRMCF371

6 DC Characteristics

6.1 Absolute Maximum Ratings

Symbol	Parameter	Min	Typ	Max	Condition
V _{DD1}	Supply Voltage	-0.3 V	-	3.6 V	Respect to VSS
V _{DD2}	Supply Voltage	-0.3 V	-	1.98 V	Respect to VSS
V _{IA}	Analog Input Voltage	-0.3 V	-	1.98 V	Respect to AVSS
V _{ID}	Digital Input Voltage	-0.3 V	-	3.65 V	Respect to VSS
T _A	Ambient Temperature	-40 °C	-	85 °C	
T _S	Storage Temperature	-65 °C	-	150 °C	

Table 1. Absolute Maximum Ratings

Caution: Stresses beyond those listed in “Absolute Maximum Ratings” may cause permanent damage to the device. These are stress ratings only and function of the device at these or any other conditions beyond those indicated in the operational sections of the specifications are not implied.

6.2 System Clock Frequency and Power Consumption

Symbol	Parameter	Min	Typ	Max	Unit
SYSCLK	System Clock	32	-	128	MHz

Table 2. System Clock Frequency

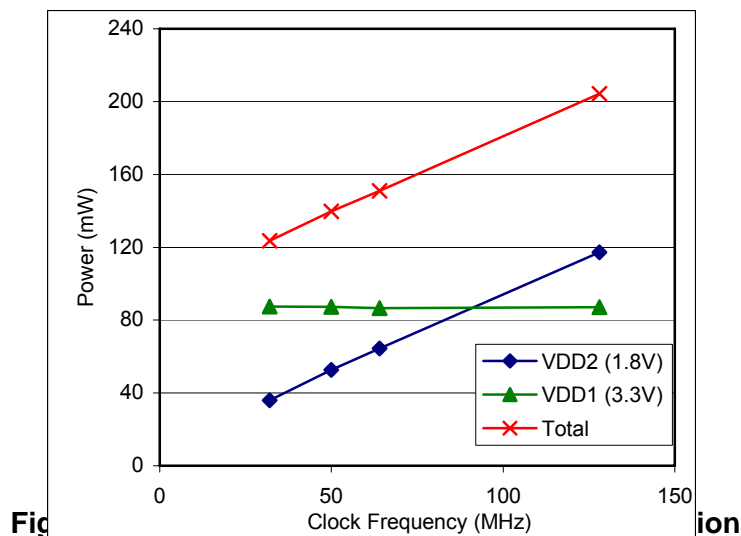

6.3 Digital I/O DC Characteristics

Symbol	Parameter	Min	Typ	Max	Condition
V _{DD1}	Supply Voltage	3.0 V	3.3 V	3.6 V	Recommended
V _{DD2}	Supply Voltage	1.62 V	1.8 V	1.98 V	Recommended
V _{IL}	Input Low Voltage	-0.3 V	-	0.8 V	Recommended
V _{IH}	Input High Voltage	2.0 V		3.6 V	Recommended
C _{IN}	Input capacitance	-	3.6 pF	-	(1)
I _L	Input leakage current		±10 nA	±1 µA	V _O = 3.3 V or 0 V
I _{OL1} ⁽²⁾	Low level output current	8.9 mA	13.2 mA	15.2 mA	V _{OL} = 0.4 V (1)
I _{OH1} ⁽²⁾	High level output current	12.4 mA	24.8 mA	38 mA	V _{OH} = 2.4 V (1)
I _{OL2} ⁽³⁾	Low level output current	17.9 mA	26.3 mA	33.4 mA	V _{OL} = 0.4 V (1)
I _{OH2} ⁽³⁾	High level output current	24.6 mA	49.5 mA	81 mA	V _{OH} = 2.4 V (1)

Table 3. Digital I/O DC Characteristics

Note:

- (1) Data guaranteed by design.
- (2) Applied to SCL/SO-SI, SDA/CS0 pins.
- (3) Applied to P1.0/T2, P1.1/RXD, P1.2/TXD, P1.3/SYNC/SCK, P1.4/CAP, P2.0/NMI, P2.1, P2.6/AOPWM0, P3.0/INT2/CS1, P3.2/INT0, P5.1/TMS, P5.2/TDO, P5.3/TDI, GATEKILL, PWMUL, PWMUH, PWMVL, PWMVH, PWMWL, PWMWH pins.

6.4 PLL and Oscillator DC characteristics

Symbol	Parameter	Min	Typ	Max	Condition
V _{PLLVD}	Supply Voltage	1.62 V	1.8 V	1.92 V	Recommended
V _{IL OSC}	Oscillator Input Low Voltage	V _{PLLSS}	-	0.2* V _{PLLVD}	V _{PLLVD} = 1.8 V (1)
V _{IH OSC}	Oscillator Input High Voltage	0.8* V _{PLLVD}		V _{PLLVD}	V _{PLLVD} = 1.8 V (1)

Table 4. PLL DC Characteristics

Note:

(1) Data guaranteed by design.

6.5 Analog I/O DC Characteristics

- OP amp for current sensing (IFB+, IFB-, IFBO)

C_{AREF} = 1nF, C_{MEXT} = 100nF. Unless specified, Ta = 25°C.

Symbol	Parameter	Min	Typ	Max	Condition
V _{AVDD}	Supply Voltage	1.71 V	1.8 V	1.89 V	Recommended
V _{OFFSET}	Input Offset Voltage	-	-	26 mV	V _{AVDD} = 1.8 V
V _I	Input Voltage Range	0 V		1.2 V	Recommended
V _{OUTSW}	OP amp output operating range	50 mV (1)	-	1.2 V	V _{AVDD} = 1.8 V
C _{IN}	Input capacitance	-	3.6 pF	-	(1)
R _{FDBK}	OP amp feedback resistor	5 kΩ	-	20 kΩ	Requested between IFBO and IFB-
OP _{GAINCL}	Operating Close loop Gain	80 db	-	-	(1)
CMRR	Common Mode Rejection Ratio	-	80 db	-	(1)
I _{SRC}	Op amp output source current	-	1 mA	-	V _{OUT} = 0.6 V (1)
I _{SNK}	Op amp output sink current	-	100 μA	-	V _{OUT} = 0.6 V (1)

Table 5. Analog I/O DC Characteristics

Note:

(1) Data guaranteed by design.

6.6 Under Voltage Lockout DC characteristics

- Based on AVDD (1.8V)

Unless specified, Ta = 25°C.

Symbol	Parameter	Min	Typ	Max	Condition
UV _{CC+}	UVcc positive going Threshold	1.53 V	1.66 V	1.71 V	V _{DD1} = 3.3 V
UV _{CC-}	UVcc negative going Threshold	1.52 V	1.62 V	1.71 V	V _{DD1} = 3.3 V
UV _{CCH}	UVcc Hysteresys	-	40 mV	-	

Table 6. UVcc DC Characteristics

6.7 CMEXT and AREF Characteristics

C_{AREF} = 1nF, C_{CMEXT} = 100nF. Unless specified, Ta = 25°C.

Symbol	Parameter	Min	Typ	Max	Condition
V _{CM}	CMEXT voltage	495 mV	600 mV	700 mV	V _{AVDD} = 1.8 V
V _{AREF}	Buffer Output Voltage	495 mV	600 mV	700 mV	V _{AVDD} = 1.8 V
ΔV _o	Load regulation (V _{DC} -0.6)	-	1 mV	-	(1)
PSRR	Power Supply Rejection Ratio	-	75 db	-	(1)

Table 7. CMEXT and AREF DC Characteristics

Note:

(1) Data guaranteed by design.

7 AC Characteristics

7.1 PLL AC Characteristics

Symbol	Parameter	Min	Typ	Max	Condition
F_{CLKIN}	Crystal input frequency	3.2 MHz	4 MHz	60 MHz	⁽¹⁾ (see figure below)
F_{PLL}	Internal clock frequency	32 MHz	50 MHz	128 MHz	⁽¹⁾
F_{LWPPW}	Sleep mode output frequency	$F_{CLKIN} \div 256$	-	-	⁽¹⁾
J_S	Short time jitter	-	200 psec	-	⁽¹⁾
D	Duty cycle	-	50 %	-	⁽¹⁾
T_{LOCK}	PLL lock time	-	-	500 μ sec	⁽¹⁾

Table 8. PLL AC Characteristics

Note:

(1) Data guaranteed by design.

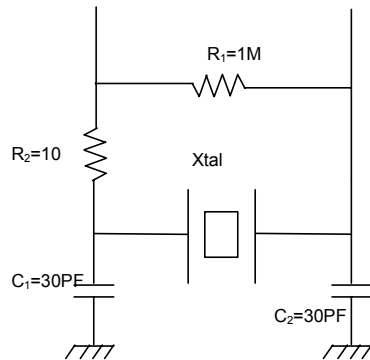

7.2 Analog to Digital Converter AC Characteristics

Unless specified, $T_a = 25^\circ\text{C}$.

Symbol	Parameter	Min	Typ	Max	Condition
T_{CONV}	Conversion time	-	-	2.05 μsec	⁽¹⁾
T_{HOLD}	Sample/Hold maximum hold time	-	-	10 μsec	Voltage droop \leq 15 LSB (see figure below)

Table 9. A/D Converter AC Characteristics

Note:

(1) Data guaranteed by design.

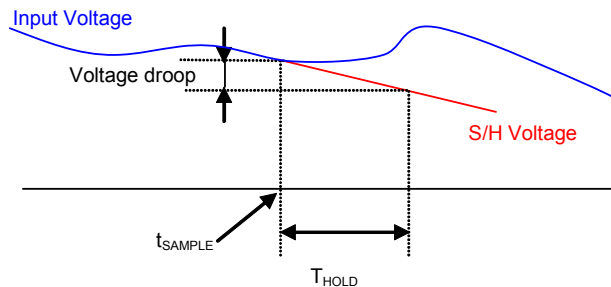

7.3 Op Amp AC Characteristics

- OP amps for current sensing (IFB+, IFB-, IFBO)

Unless specified, $T_a = 25^\circ\text{C}$.

Symbol	Parameter	Min	Typ	Max	Condition
OP_{SR}	OP amp slew rate	-	10 V/ μsec	-	$V_{\text{AVDD}} = 1.8 \text{ V}$, $CL = 33 \text{ pF}$ ⁽¹⁾
OP_{IMP}	OP input impedance	-	$10^8 \Omega$	-	⁽¹⁾
T_{SET}	Settling time	-	400 ns	-	$V_{\text{AVDD}} = 1.8 \text{ V}$, $CL = 33 \text{ pF}$ ⁽¹⁾

Table 10. Current Sensing OP amp Amp AC Characteristics

Note:

(1) Data guaranteed by design.

7.4 SYNC to SVPWM and A/D Conversion AC Timing

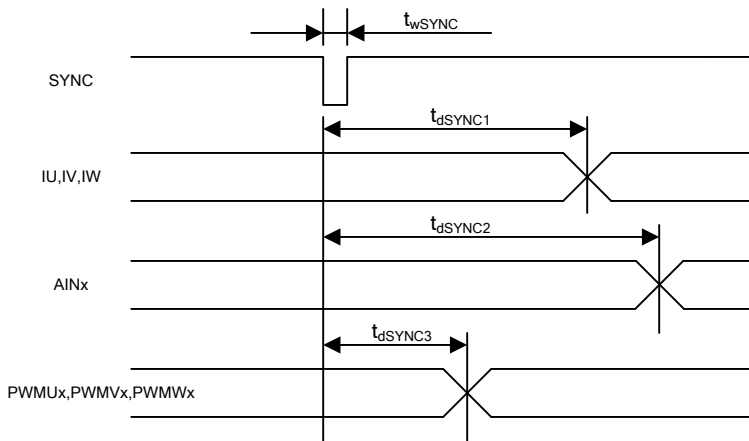

Unless specified, $T_a = 25^\circ\text{C}$.

Symbol	Parameter	Min	Typ	Max	Unit
t_{wSYNC}	SYNC pulse width	-	32	-	SYSClk
t_{dSYNC1}	SYNC to current feedback conversion time	-	-	100	SYSClk
t_{dSYNC2}	SYNC to AIN0-6 analog input conversion time	-	-	200	SYSClk ⁽¹⁾
t_{dSYNC3}	SYNC to PWM output delay time	-	-	2	SYSClk

Table 11. SYNC AC Characteristics

Note:

(1) AIN1 through AIN6 channels are converted once every 6 SYNC events

7.5 GATEKILL to SVPWM AC Timing

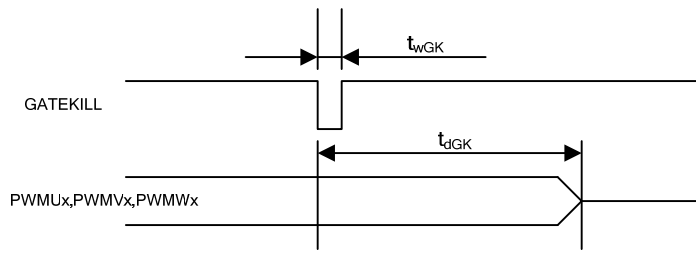

Unless specified, $T_a = 25^\circ\text{C}$.

Symbol	Parameter	Min	Typ	Max	Unit
t_{wGK}	GATEKILL pulse width	32	-	-	SYSCLK
t_{dGK}	GATEKILL to PWM output delay	-	-	100	SYSCLK

Table 12. GATEKILL to SVPWM AC Timing

7.6 Interrupt AC Timing

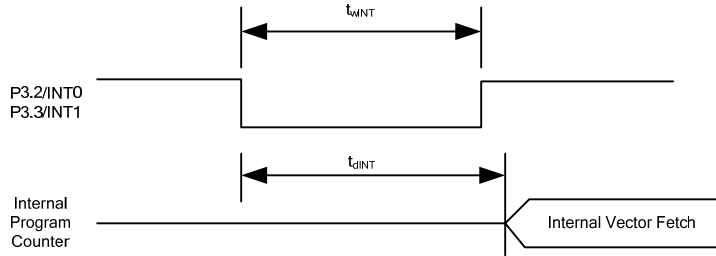

Unless specified, $T_a = 25^\circ\text{C}$.

Symbol	Parameter	Min	Typ	Max	Unit
t_{WINT}	INT0, INT1 Interrupt Assertion Time	4	-	-	SYSCLK
t_{dINT}	INT0, INT1 latency	-	-	4	SYSCLK

Table 13. Interrupt AC Timing

7.7 I²C AC Timing

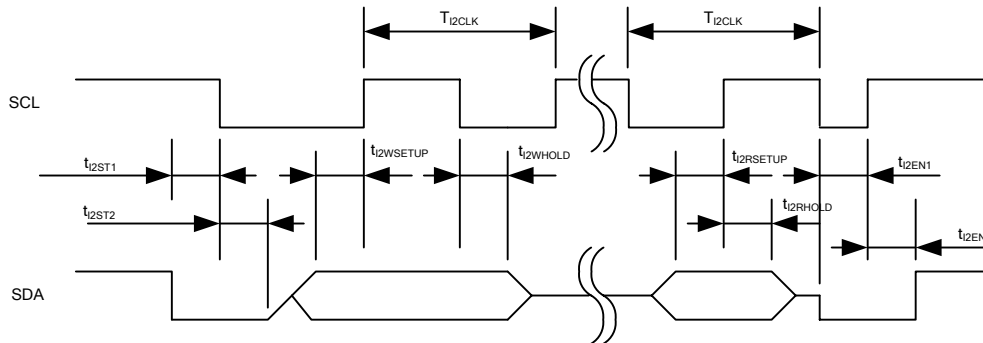

Unless specified, $T_a = 25^\circ\text{C}$.

Symbol	Parameter	Min	Typ	Max	Unit
T_{I2CLK}	I ² C clock period	10	-	8192	SYCLK
t_{I2ST1}	I ² C SDA start time	0.25	-	-	T_{I2CLK}
t_{I2ST2}	I ² C SCL start time	0.25	-	-	T_{I2CLK}
$t_{I2WSETUP}$	I ² C write setup time	0.25	-	-	T_{I2CLK}
$t_{I2WHOLD}$	I ² C write hold time	0.25	-	-	T_{I2CLK}
$t_{I2RSETUP}$	I ² C read setup time	I ² C filter time ⁽¹⁾	-	-	SYCLK
$t_{I2RHOLD}$	I ² C read hold time	1	-	-	SYCLK

Table 14. I²C AC Timing

Note:

- (1) I²C read setup time is determined by the programmable filter time applied to I²C communication.

7.8 SPI AC Timing

7.8.1 SPI Write AC timing

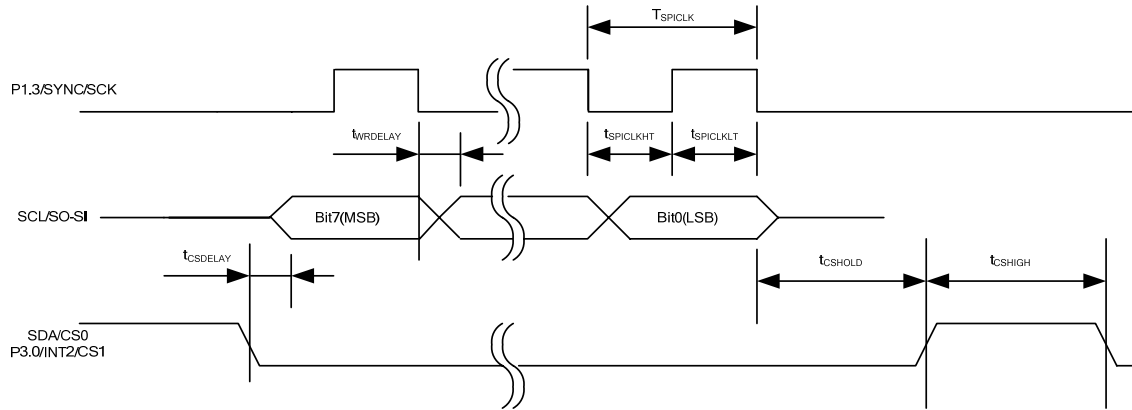

Unless specified, $T_a = 25^\circ\text{C}$.

Symbol	Parameter	Min	Typ	Max	Unit
T_{SPICLK}	SPI clock period	4	-	-	SYSCCLK
t_{SPICLKHT}	SPI clock high time	-	1/2	-	T_{SPICLK}
t_{SPICLKLT}	SPI clock low time	-	1/2	-	T_{SPICLK}
t_{CSDELAY}	CS to data delay time	-	-	10	nsec
t_{WRDELAY}	CLK falling edge to data delay time	-	-	10	nsec
t_{CSHIGH}	CS high time between two consecutive byte transfer	1	-	-	T_{SPICLK}
t_{CSHOLD}	CS hold time	-	1	-	T_{SPICLK}

Table 15. SPI Write AC Timing

7.8.2 SPI Read AC Timing

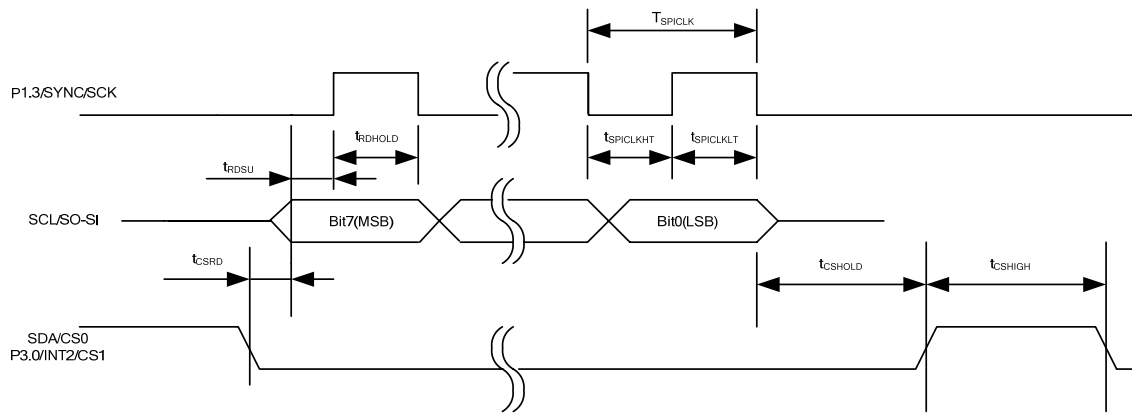

Unless specified, $T_a = 25^\circ\text{C}$.

Symbol	Parameter	Min	Typ	Max	Unit
T_{SPICLK}	SPI clock period	4	-	-	SYSCCLK
t_{SPICLKHT}	SPI clock high time	-	1/2	-	T_{SPICLK}
t_{SPICLKLT}	SPI clock low time	-	1/2	-	T_{SPICLK}
t_{CSRDL}	CS to data delay time	-	-	10	nsec
t_{RDSU}	SPI read data setup time	10	-	-	nsec
t_{RDHOLD}	SPI read data hold time	10	-	-	nsec
t_{CSHIGH}	CS high time between two consecutive byte transfer	1	-	-	T_{SPICLK}
t_{CSHOLD}	CS hold time	-	1	-	T_{SPICLK}

Table 16. SPI Read AC Timing

7.9 UART AC Timing

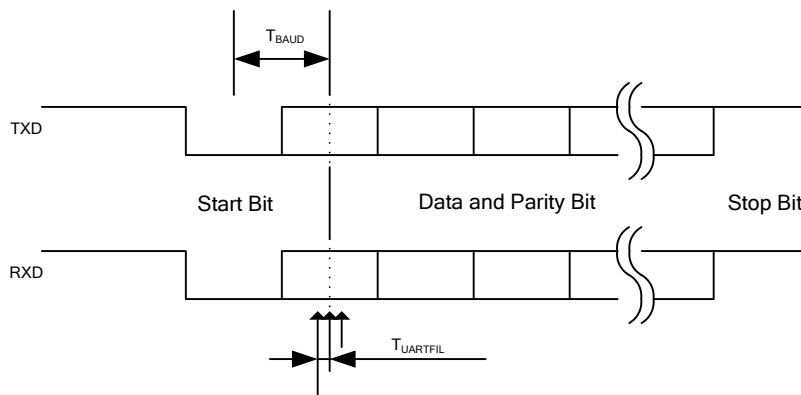

Unless specified, $T_a = 25^\circ\text{C}$.

Symbol	Parameter	Min	Typ	Max	Unit
T_{BAUD}	Baud Rate Period	-	57600	-	bit/sec
$T_{UARTFIL}$	UART sampling filter period ⁽¹⁾	-	1/16	-	T_{BAUD}

Table 17. UART AC Timing

Note:

- (1) Each bit including start and stop bit is sampled three times at center of a bit at an interval of $1/16 T_{BAUD}$. If three sampled values do not agree, then UART noise error is generated.

7.10 CAPTURE Input AC Timing

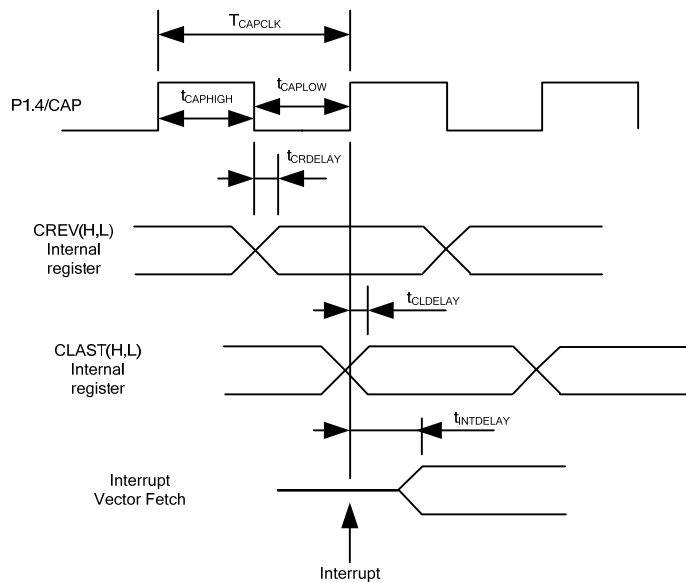

Unless specified, $T_a = 25^\circ\text{C}$.

Symbol	Parameter	Min	Typ	Max	Unit
T_{CAPCLK}	CAPTURE input period	8	-	-	SYSCLK
$t_{CAPHIGH}$	CAPTURE input high time	4	-	-	SYSCLK
t_{CAPLOW}	CAPTURE input low time	4	-	-	SYSCLK
$t_{CRDELAY}$	CAPTURE falling edge to capture register latch time	-	-	4	SYSCLK
$t_{CLDELAY}$	CAPTURE rising edge to capture register latch time	-	-	4	SYSCLK
$t_{INTDELAY}$	CAPTURE input interrupt latency time	-	-	4	SYSCLK

Table 18. CAPTURE AC Timing

7.11 JTAG AC Timing

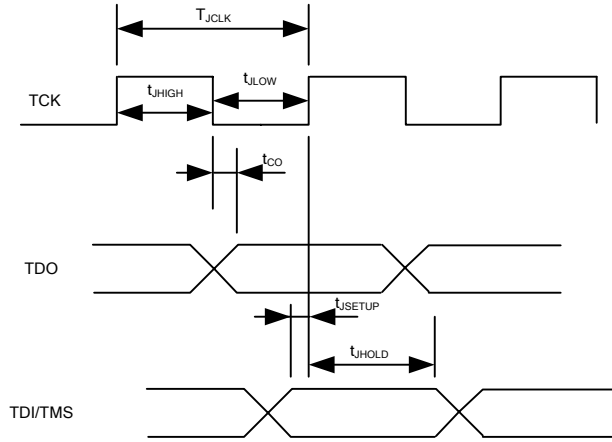

Unless specified, $T_a = 25^\circ\text{C}$.

Symbol	Parameter	Min	Typ	Max	Unit
T_{JCLK}	TCK Period	-	-	50	MHz
t_{JHIGH}	TCK High Period	10	-	-	nsec
t_{JLOW}	TCK Low Period	10	-	-	nsec
t_{CO}	TCK to TDO propagation delay time	0	-	5	nsec
t_{JSETUP}	TDI/TMS setup time	4	-	-	nsec
t_{JHOLD}	TDI/TMS hold time	0	-	-	nsec

Table 19. JTAG AC Timing

8 Pin List

Pin Number	Pin Name	Internal Pull-up /Pull-down	Pin Type	Description
1	XTAL0		I	Crystal input
2	XTAL1		O	Crystal output
3	P1.0/T2		I/O	Discrete programmable I/O or Timer/Counter 2 input
4	P1.1/RXD		I/O	Discrete programmable I/O or UART receive input
5	P1.2/TXD		I/O	Discrete programmable I/O or UART transmit output
6	P1.3/SYNC/ SCK		I/O	Discrete programmable I/O or SYNC output or SPI clock output, needs to be pulled up to VDD1 in order to boot from I ² C EEPROM
7	P1.4/CAP		I/O	Discrete programmable I/O or Capture Timer input
8	VDD2		P	1.8V digital power
9	VSS		P	Digital common
10	VDD1		P	3.3V digital power
11	P2.0/NMI		I/O	Discrete I/O or Non Maskable Interrupt
12	P2.1		I/O	Discrete I/O
13	P2.6/AOPWM		I/O	Discrete I/O or PWM digital output
14	VDD2		P	1.8V digital power
15	VSS		P	Digital common
16	AIN0		I	Analog input channel 0, 0-1.2V range, needs to be pulled down to AVSS if unused
17	AVDD		P	1.8V analog power
18	AVSS		P	Analog common
19	AIN1		I	Analog input channel 1, 0-1.2V range, needs to be pulled down to AVSS if unused
20	CMEXT		O	Unbuffered 0.6V output. Capacitor needs to be connected.
21	AREF		O	Analog reference voltage output (0.6V)
22	IFB-		I	Single shunt current sensing OP amp input (-)
23	IFB+		I	Single shunt current sensing OP amp input (+)
24	IFBO		O	Single shunt current sensing OP amp output
25	AIN2		I	Analog input channel 2, 0-1.2V range, needs to be pulled down to AVSS if unused
26	VDD2		P	1.8V digital power
27	VSS		P	Digital common
28	VDD1		P	3.3V digital power
29	GATEKILL		I	PWM shutdown input, 2- μ sec digital filter, configurable either high or low true.
30	PWMWL	70 k Ω Pull up	O	PWM gate drive for phase W low side, configurable either high or low true
31	PWMWH	70 k Ω Pull up	O	PWM gate drive for phase W high side, configurable either high or low true
32	PWMVL	70 k Ω Pull up	O	PWM gate drive for phase V low side, configurable either high or low true

Pin Number	Pin Name	Internal Pull-up /Pull-down	Pin Type	Description
33	PWMVH	70 kΩ Pull up	O	PWM gate drive for phase V high side, configurable either high or low true
34	PWMUL	70 kΩ Pull up	O	PWM gate drive for phase U low side, configurable either high or low true
35	PWMUH	70 kΩ Pull up	O	PWM gate drive for phase U high side, configurable either high or low true
36	P3.0/INT2/CS1		I/O	Discrete programmable I/O or external interrupt 2 input or SPI chip select 1
37	P3.2/NINT0		I/O	Discrete programmable I/O or external interrupt 0 input
38	VSS		P	Digital common
39	SCL/SO-SI		I/O	I2C clock or SPI data
40	SDA/CS0		I/O	I2C data or SPI chip select 0
41	P5.1/TMS		I/O	Discrete I/O or JTAG test mode select
42	P5.2/TDO		I/O	Discrete I/O or JTAG test data output
43	P5.3/TDI		I/O	Discrete I/O or JTAG test data input
44	TCK		I	JTAG test clock input
45	TSTMOD	58 kΩ pull down	I	Test mode input, must be tied to VSS
46	RESET		I/O	Reset, low true, Schmitt trigger input
47	PLLVDD		P	1.8V PLL power
48	PLLVSS		P	PLL ground

Table 20. Pin List

9 Package Dimensions

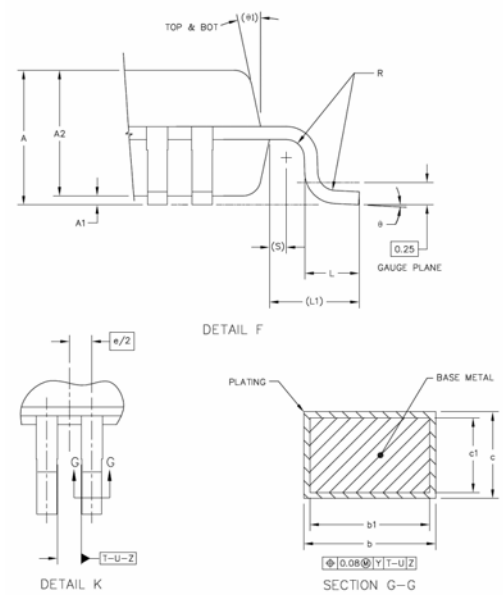
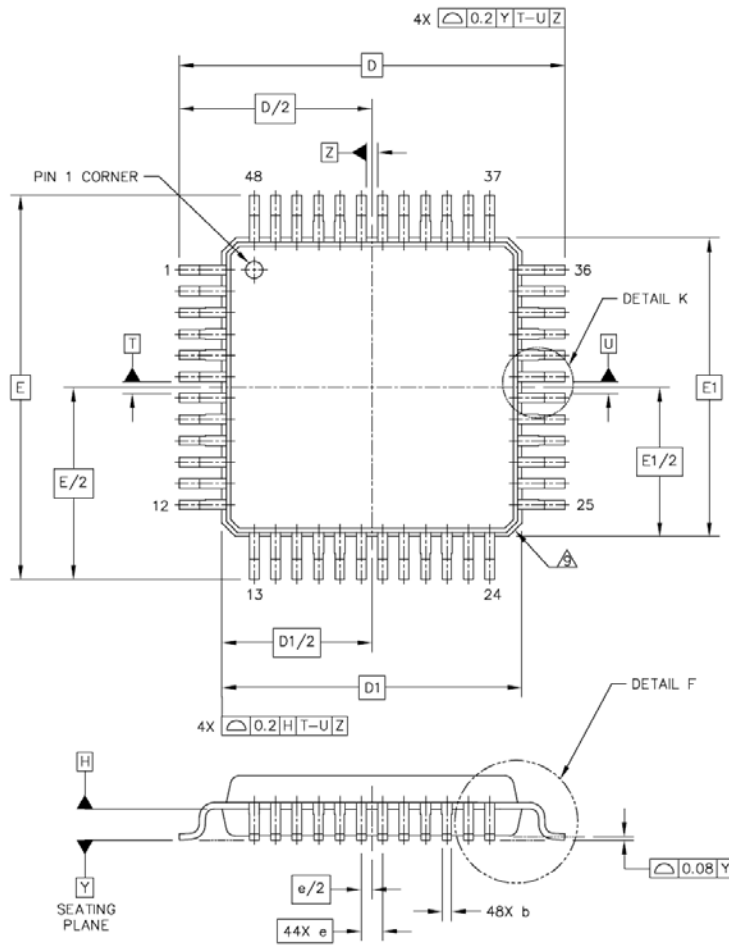

NOTES:

1. DIMENSIONS ARE IN MILLIMETERS.
 2. INTERPRET DIMENSIONS AND TOLERANCES PER ASME Y14.5M-1994.
 3. DATUM PLANE H IS LOCATED AT BOTTOM OF LEAD AND IS COINCIDENT WITH THE LEAD WHERE THE LEAD EXITS THE PLASTIC BODY AT THE BOTTOM OF THE PARTING LINE.
 4. DATUM T, U AND Z TO BE DETERMINED AT DATUM PLANE H.
 5. DIMENSIONS D AND E TO BE DETERMINED AT SEATING PLANE Y.
 6. DIMENSIONS D1 AND E1 DO NOT INCLUDE MOLD PROTRUSION. ALLOWABLE PROTRUSION IS 0.25 PER SIDE. DIMENSIONS D1 AND E1 DO INCLUDE MOLD MISMATCH AND ARE DETERMINED AT DATUM PLANE H.
 7. DIMENSION b DOES NOT INCLUDE DAM BAR PROTRUSION. DAM BAR PROTRUSION SHALL NOT CAUSE THE b DIMENSION TO EXCEED 0.35.
 8. MINIMUM SOLDER PLATE THICKNESS SHALL BE 0.0076.
- △ EXACT SHAPE OF EACH CORNER IS OPTIONAL.

DIM	MIN	MAX	DIM	MIN	MAX	DIM	MIN	MAX
A	1.4	1.6	L1	1 REF				
A1	0.05	0.15	R	0.15	0.25			
A2	1.35	1.45	S	0.2 REF				
b	0.17	0.27	θ	1°	5°			
b1	0.17	0.23	θ1	12° REF				
c	0.09	0.2						
c1	0.09	0.16						
D		9 BSC						
D1		7 BSC						
e		0.5 BSC						
E		9 BSC						
E1		7 BSC						
L	0.5	0.7						

10 Part Marking Information

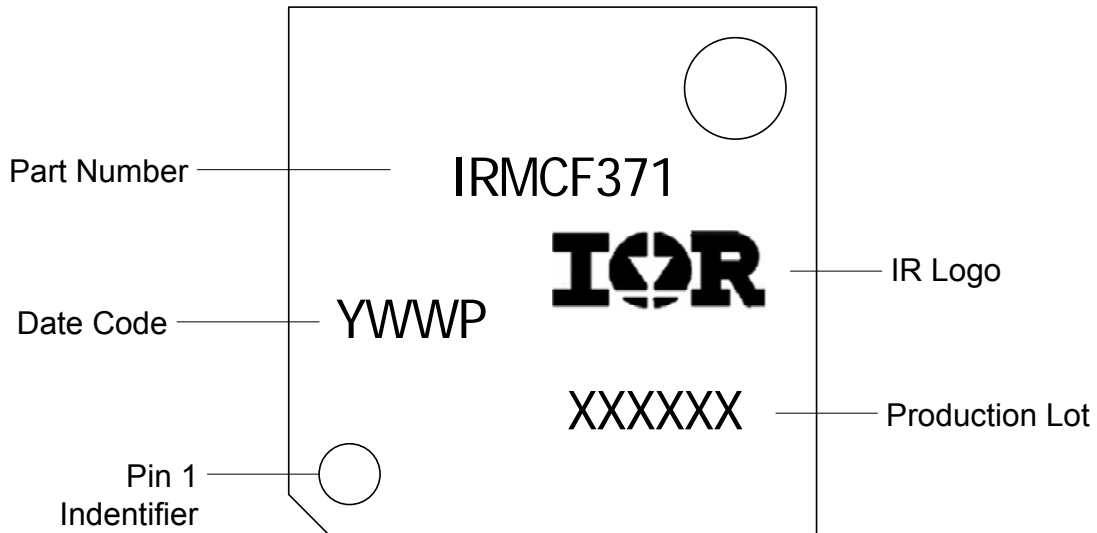

Order Information

Lead-Free Part in 48-lead QFP
Moisture sensitivity rating – MSL3

Part number	Order quantities
IRMCF371TR	2000 parts on tape and reel in dry pack
IRMCF371TY	2500 parts on trays (250 parts per tray) in dry pack

International
IR Rectifier

The LQFP-48 is MSL3 qualified
 This product has been designed and qualified for the industrial level
 Qualification standards can be found at www.irf.com <<http://www.irf.com>>
IR WORLD HEADQUARTERS: 233 Kansas St., El Segundo, California 90245, Tel: (310) 252-7105
 Data and specifications subject to change without notice. 12/05/2006

Mouser Electronics

Authorized Distributor

Click to View Pricing, Inventory, Delivery & Lifecycle Information:

[Infineon:](#)

[IRMCF371TR](#) [IRMCF371TY](#)