



NXP demo board for Fast-mode Plus 4-bit I²C LED controller PCA9633

Easily test and demonstrate LED dimming and blinking

This flexible, easy-to-program board makes it simple to test and demonstrate LED blinking and dimming. Integrated Fast-mode Plus supports faster updates and longer buses with higher capacitance.

Key features

- ▶ Individual and group LED control with up to 256 levels of brightness
- ▶ Familiar I²C commands
- ▶ Fast-mode Plus for longer LED strings and faster updates
- ▶ Output Enable pin for full control of multiple devices controlling LEDs
- ▶ Preprogrammed with six operating modes
- ▶ User-reprogrammable for custom color patterns
- ▶ Daisy-chain configurations with up to eight boards

The PCA9633 demo board is a complete, ready-to-run test environment for dimming and blinking LEDs. Designed for flexibility, it comes pre-programmed with six operating modes, including color wash and random color, and can be reprogrammed to create custom color patterns.

The board uses familiar I²C commands and supports the higher drive of Fast-mode Plus (1-MHz and 30-mA), so designs can use longer strings of LEDs and higher frequencies.

The board is configured with four LEDs, one each for red, green, blue, and amber. The LEDs are connected to the PCA9633, which has a total of five 8-bit Pulse Width Modulators (PWMs) for dimming and blinking the LEDs. The first four PWMs are used to control each of the four LEDs individually, with up to

256 brightness levels. The fifth is used for group control, dimming, or blinking all the LEDs simultaneously to create 256 levels of brightness with combined colors.

The PCA9633 has four individually controlled outputs, configurable as 25-mA open drains or 10-mA/25-mA push-pulls, that can be selected for off, on, dim, or dim with global control. An Output Enable pin makes it easy to configure hardware dimming or synchronized blinking over multiple devices.

Seven address pins allow up to 126 I²C addresses on the I²C-bus. Additionally, four I²C addresses are software programmable, so groups of devices can be assigned the same address and controlled with a single command.

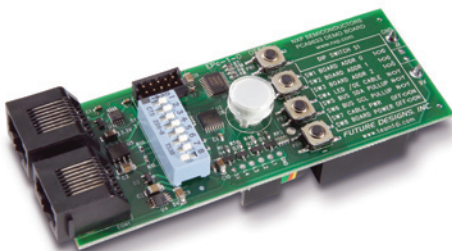

The board includes external 60-V FET drivers, which can be connected to high-current, 350-mA LEDs. A four-key keypad gives the user direct control over the RGBA color mixing and light patterns. Power can be supplied by the board's 9-V battery or via an external power connector. The RJ45 connector and cable can be used to daisy-chain multiple boards, enabling the microcontroller on one board to act as the master for up to seven additional boards.

Reprogramming the microcontroller

Reprogramming the microcontroller requires an in-circuit programmer (ICP), Flash Magic software (for loading the microcontroller with compiled hex files), and source code. For the ICP, NXP recommends the USB-ICP-LPX9xx, available at www.teamfdi.com. Flash Magic software is sponsored by NXP and is available from the Embedded Systems Academy (www.esacademy.com/software/flashmagic/).

Devices on the PCA9633 demo board

Device	Description
PCA9633	Fast-mode Plus 4-bit I ² C-bus LED controller with individual 8-bit, 256-step PWMs for each LED plus a fifth 8-bit, 256-step group PWM for dimming or blinking combined colors.
P89LPC925	Flash microcontroller. Uses embedded firmware to control the PCA9633. User-programmable via 10-pin pin header and an external ICP-style programmer.
P82B96	Buffer for microcontroller. Supports the higher drive of Fast-mode Plus, and enables off-board operation.
SW 1, 2, 3	Sets address pins to GND or V _{CC} so up to eight boards can be connected to the same microcontroller.
SW 4	Sends Output Enable signal to other boards.
SW 5, 6	Turns on bus pull-up resistors for master and termination cards only.
SW 7	Sends power of 9-V battery over cables.
SW 8	Turns on power to 9-V battery.
FETs	60-V, 350-mA devices that use with high-brightness LEDs.
RJ45 connector	Supplies additional cards with I ² C-bus, power, and Output Enable signals.

Operating modes supported by the PCA9633 demo board		
Mode 1	Auto Demonstration Mode	Displays Mode 2 for 10 seconds, Mode 3 for 10 seconds, and then repeats. Automatically selected at start-up.
Mode 2	Color Wash Mode	Continuously blends colors.
Mode 3	Random Color Mode	Randomly shows different colors without blending transitions.
Mode 4	User Color Mode	Displays user-selected colors. User can specify output of all five PWMs.
Mode 5	Multiple-card Chase Mode	Generates a chase pattern of multiple colors using the PCA9633's group-call feature and additional cards. Color combinations can use two (amber/red), three (amber/red/green), or four (amber/red/green/blue) colors. Supports up to eight boards (master plus seven boards) connected via the RJ45 jacks.
Mode 6	Output Enable Control Mode	Demonstrates the Output Enable pin, which places the LED outputs in High Z. Changes the LED diffuser color to purple and blinks all LEDs at the same rate.

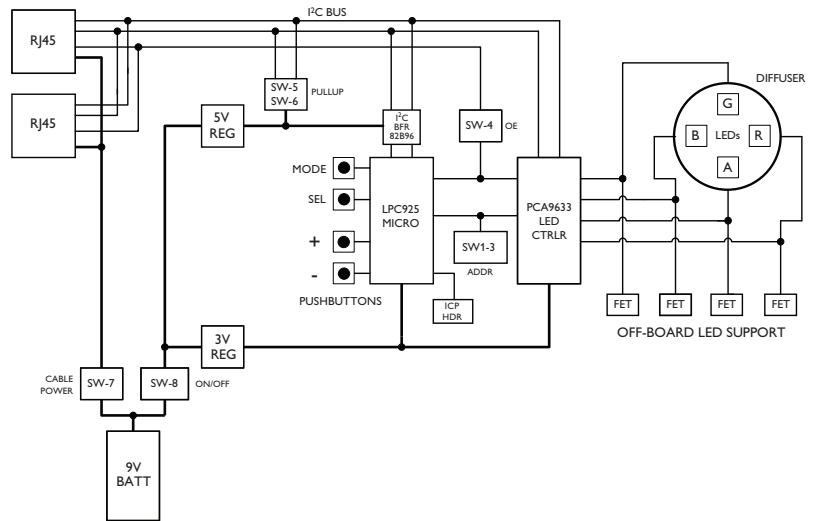

The PCA9633 demo board

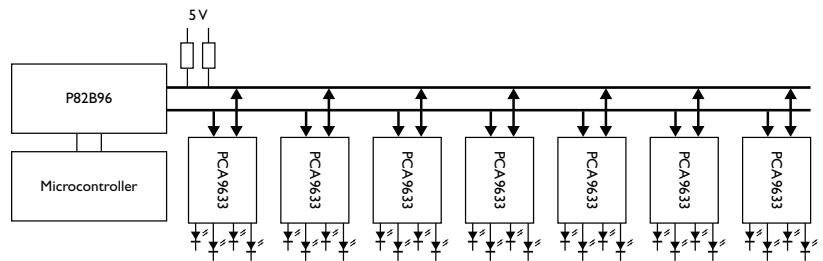

The PCA9633 demo board configured in Multiple-card Chase Mode (Mode 5)



Mouser Electronics

Authorized Distributor

Click to View Pricing, Inventory, Delivery & Lifecycle Information:

[NXP:](#)

[OM6276](#)