

PART NUMBER	REV	FIRST USED	POWER UNIT	FEED TYPE
1852556-1	A	122500-1	LEADMAKER & BENCH MODEL G	POST FEED
1852556-2	A	565435-5	BENCH MODEL K	POST FEED
7-1852556-7	A	-	SPARE PARTS	-

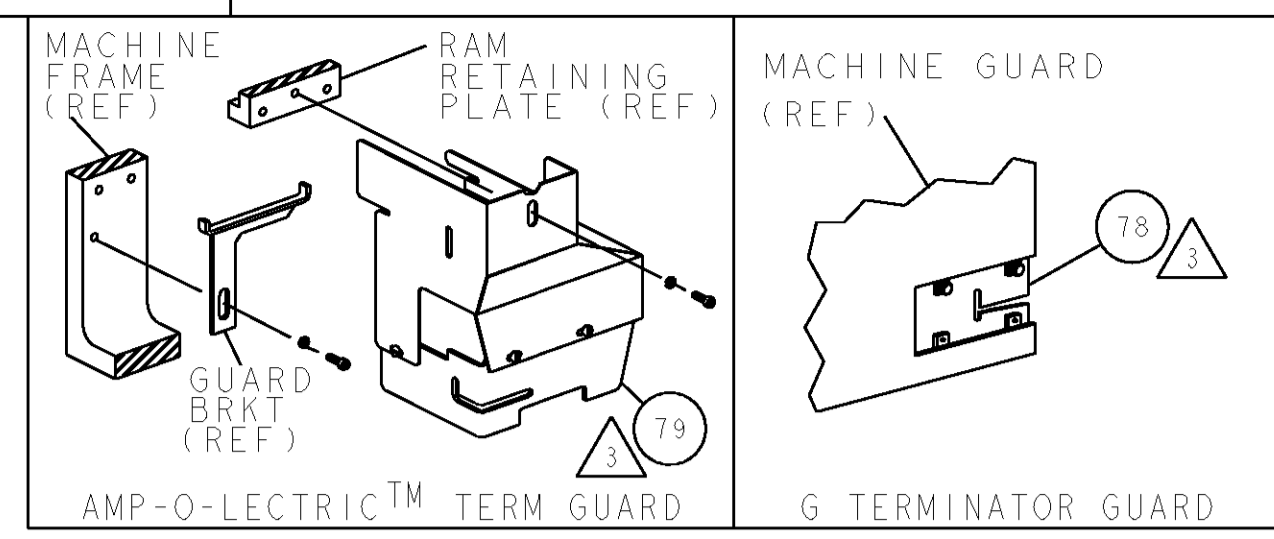

TE PN		COMP PN		CHANG KOHLER TERMINAL - TE CRIMP SPECS	
1949495-1	-	CH-60322	-		
-	-	PAD LTR	-	CRIMP HEIGHT	WIRE SIZE
-	-	A	-	1.52±0.05mm [.060±.002]	18AWG
-	-	B	-	1.45±0.05mm [.057±.002]	20AWG
-	-	C	-	-	-
-	-	D	-	-	-
-	-	CRIMP	SIZE	TYPE	RANGE
-	-	WIRE	2.54mm [.100]	F	14-20 AWG
-	-	INSUL	3.30mm [.130]	F	∅2.3mm MAX
WIRE STRIP LENGTH	4.45-4.83	TERM APPL SPEC	NONE	FEED	18.03
		APPL INSTRUCTIONS	408-8039	SET UP GAGE	458638-1

LOC	DIST	REV	DESCRIPTION	DATE	BY	APPD
A	66		RELEASED	01OCT2007	BH	BH

- △ RECOMMENDED SPARE PARTS
- △ GREASE LIGHTLY
- △ GUARD MUST BE IN PLACE WHEN OPERATING APPLICATOR IN A BENCH MACHINE

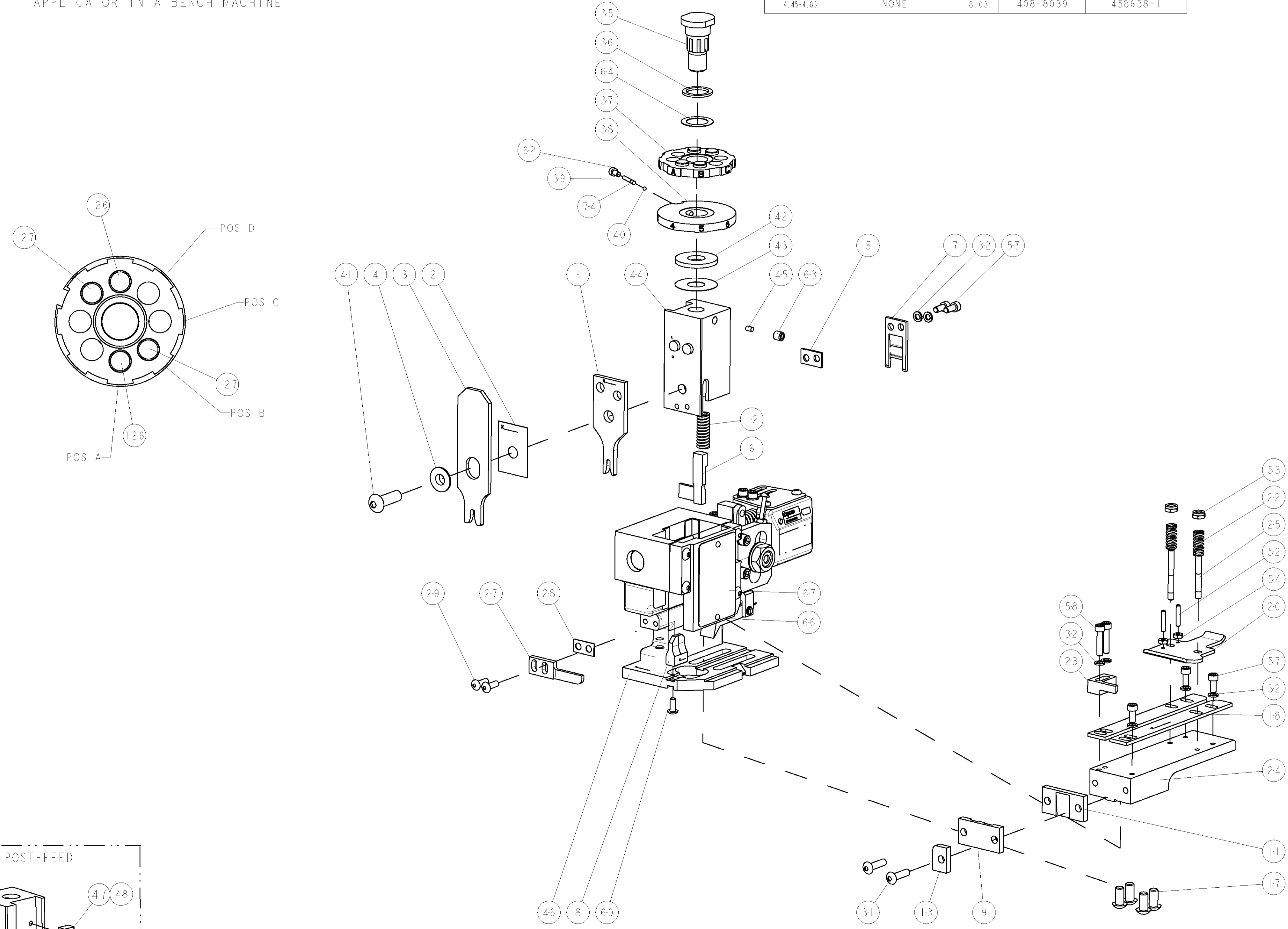

2	2	-	4-354779-3	PIN, WIRE DISC, .3205	127
2	2	-	3-354779-7	PIN, WIRE DISC, .3175	126
REF	-	-	455745-1	GUARD WINDOW	79
REF	REF	-	679532-1	INSERT, GUARD	78
1	1	-	690603-1	SPRING ASSIST AMP-O-MATOR APPLICATOR	74
1	1	-	217238-1	GENERAL INSTRUCTION PKG	72
1	1	-	4088039	EF APPL INST 408-8039	71
1	1	-	461264-1	PLATE, IDENTIFICATION	67
2	2	-	21017-2	SCREW, DRIVE	66
1	1	-	986950-1	WASHER, FLAT PRECISION	64
1	1	-	21009-2	SCR, SET, SELF LOCKING 1/4-20 X .250	63
1	1	-	23030-1	SCR, SKT HD CAP 6-32 X .25	62
1	1	-	22733-8	SCR, BHSC, SELF-LOCKING, 8-32 X .375	60
2	2	-	2-21000-9	SCR, SKT HD CAP 8-32 X .750	58
3	3	-	2-21000-6	SCR, SKT HD CAP 8-32 X .375	57
2	2	-	2-21000-6	SCR, SKT HD CAP 8-32 X .375	56
2	2	-	21018-4	NUT, HEX, REG 4-40	54
2	2	-	21022-2	NUT, LOCK, HEX, TORQUE, 8-32	53
2	2	-	2-21006-6	SCR, SET, CUP POINT 4-40 X .625	52
1	1	-	1-21002-7	SCR, BTN SKT CAP 6-32 X .375	49
1	-	-	690501-3	CAM, POST FEED, 1 1/8	48
-	-	-	690501-4	CAM, POST FEED, 1 5/8	47
1	1	-	458980-1	SUB ASSY, APPLICATOR FRAME	46
1	1	-	690191-1	PLUG, NYLON	45
1	1	-	455674-1	RAM	44
1	1	-	690125-1	SHIM SUB-ASSY	43
1	1	-	690124-1	WASHER, RAM (.115)	42
1	1	-	7-21002-9	SCR, BTN SKT HD CAP 5/16-24 X 1.00	41
1	1	-	23241-6	BALL, STEEL	40
1	1	-	690170-1	SPRING, COMPRESSION	39
1	1	-	1-690142-2	DISC, INSULATION	38
1	1	-	354777-1	WIRE DISC, ASSEMBLY	37
1	1	-	22480-5	SPRING, COMPRESSION	36
1	1	-	690212-1	POST, RAM	35
7	7	-	21024-4	WASHER, SPRG LOCK, REG NO 8	32
2	2	-	2-21002-9	SCR, BTN SKT HD CAP 10-32 X .750	31
2	2	-	2-21002-2	SCR, BTN SKT HD CAP 8-32 X .500	29
1	1	-	1-690451-7	SPACER, STRIPPER	28
1	1	-	240639-1	STRIPPER (MACHINING)	27
2	2	-	22354-8	STUD, THREADED	25
1	1	-	455678-1	PLATE, STRIP GUIDE	24
1	1	-	240825-3	PLATE, STRIP HOLD DOWN	23
2	2	-	4-22281-1	SPRING, DRAG	22
1	1	-	454177-1	DRAG	20
2	2	-	454204-3	GUIDE, LOWER STRIP	18
4	4	-	3-21002-3	SCR, BTN SKT HD CAP 1/4-20 X .500	17
1	1	-	690481-2	SPACER, HOLD DOWN	13
1	1	-	23846-1	SPRING, DIE	12
1	1	-	240644-1	PLATE, REAR SHEAR	11
-	-	-	-	-	10
1	1	-	690482-6	PLATE, FRONT SHEAR	9
1	1	-	1-1633249-9	ANVIL, COMBINATION	8
1	1	-	690474-6	BLADE, SLUG	7
1	1	-	7-455892-5	HOLD DOWN, TERMINAL	6
1	1	-	4-240641-8	SPACER	5
1	1	-	238009-1	BLOCK, FL CRIMPER SPACER	4
1	1	-	1-456134-9	CRIMPER, INSULATION F PREMIUM	3
1	1	-	455888-3	SPACER, CRIMPER	2
1	1	-	3-456407-2	CRIMPER, WIRE PREMIUM	1

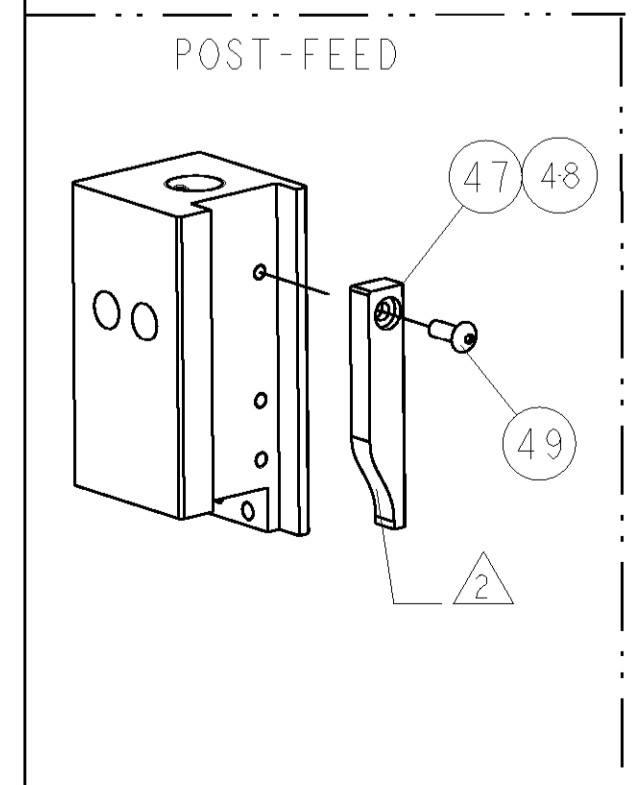

ITEM NO	U/M	PART NO	DESCRIPTION
-77	-2	-1	U/M PART NO DESCRIPTION ITEM NO

DIMENSIONS: INCHES 	TOLERANCES UNLESS OTHERWISE SPECIFIED: 0 PLC ±.1 1 PLC ±0.01 2 PLC ±0.001 3 PLC ±0.001 4 PLC ±0.001 ANGLES ±.001	DWG: B.HIGMAN CHK: B.HIGMAN APVD: J.FELBIN DATE: 11SEPT2007 NAME: END FEED HDM APPLICATOR PRODUCT SPEC: - APPLICATION SPEC: - WEIGHT: - FINISH: - CUSTOMER DRAWING	Tyco Electronics Harrisburg, PA 17105-3608 SCALE: 3:5 SHEET 1 OF 1 REV A
---------------------------	--	---	--

Mouser Electronics

Authorized Distributor

Click to View Pricing, Inventory, Delivery & Lifecycle Information:

[TE Connectivity:](#)

[1852556-2](#)