

VIEW WITH ASSEMBLED COVER  
 ANSICHT MIT MONTIERTEM DECKEL

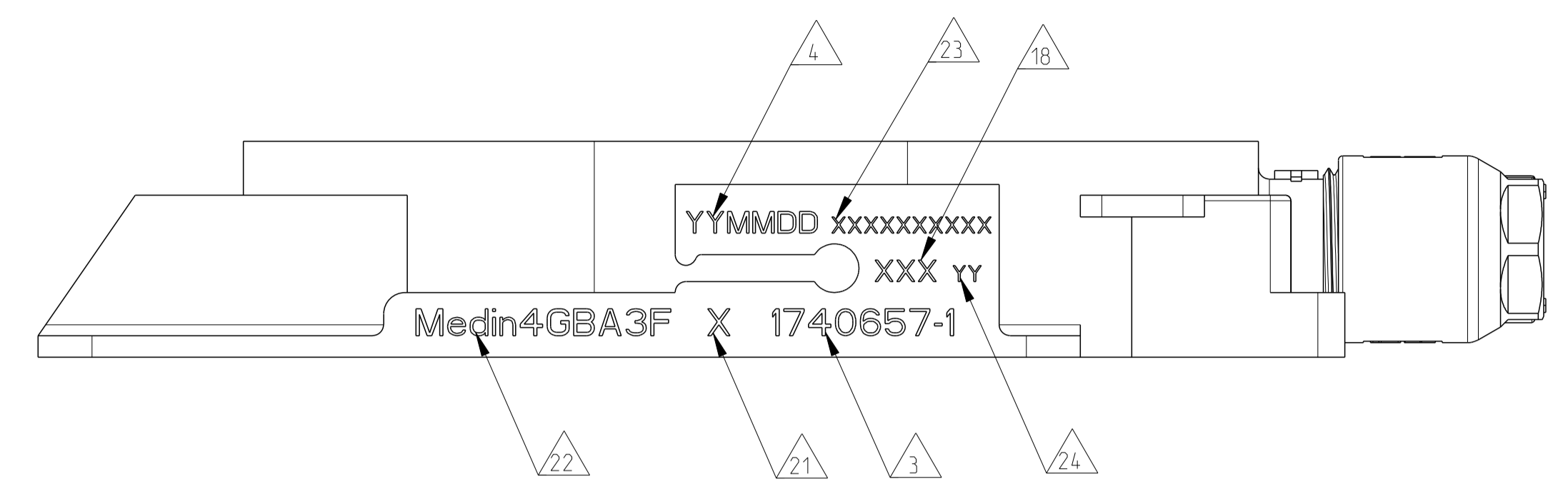

VIEW WITH ASSEMBLED COVER  
 ANSICHT MIT MONTIERTEM DECKEL

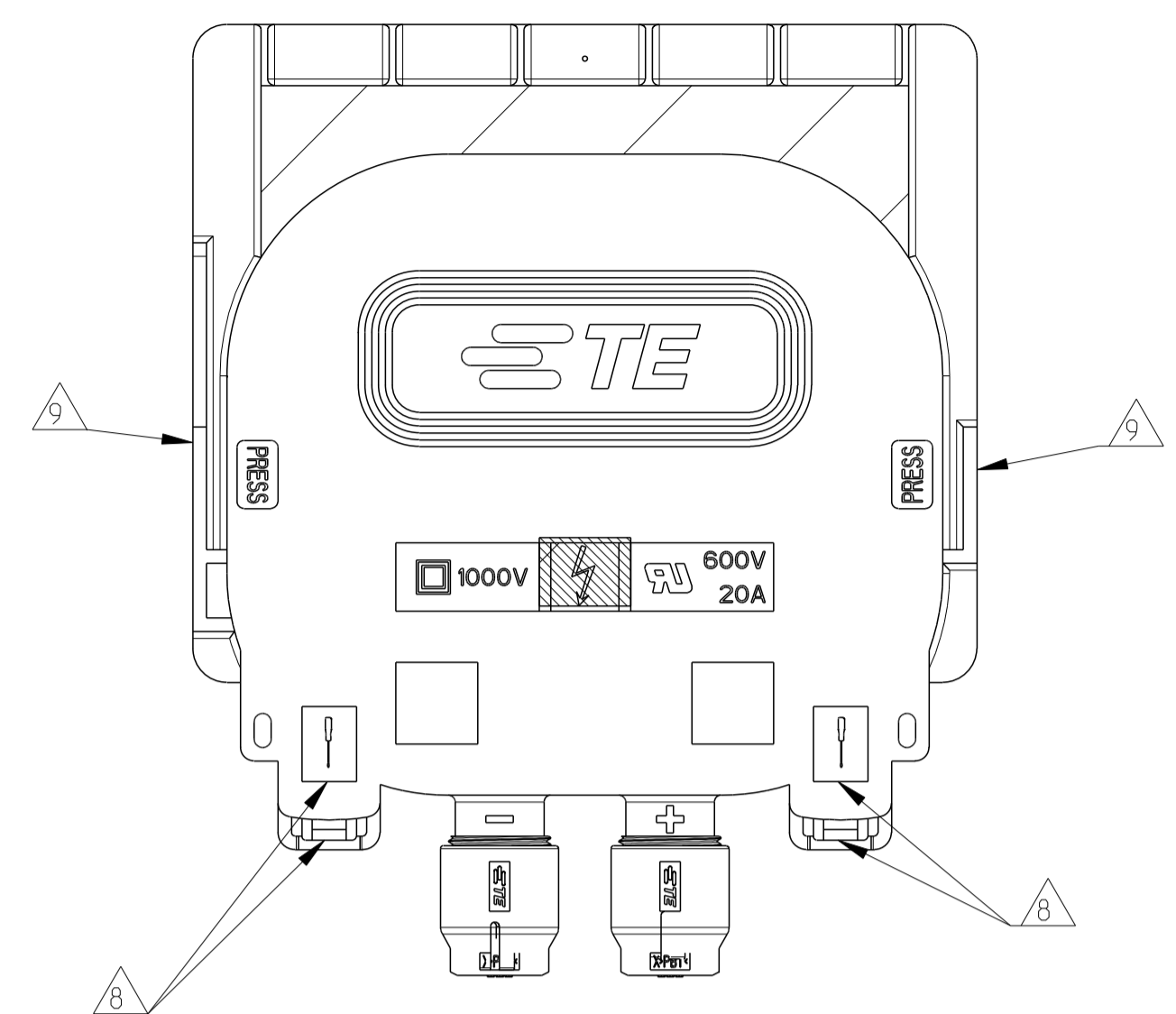

SCALE 1:1 / M 1:1

VIEW WITH ASSEMBLED COVER  
 ANSICHT MIT MONTIERTEM DECKEL

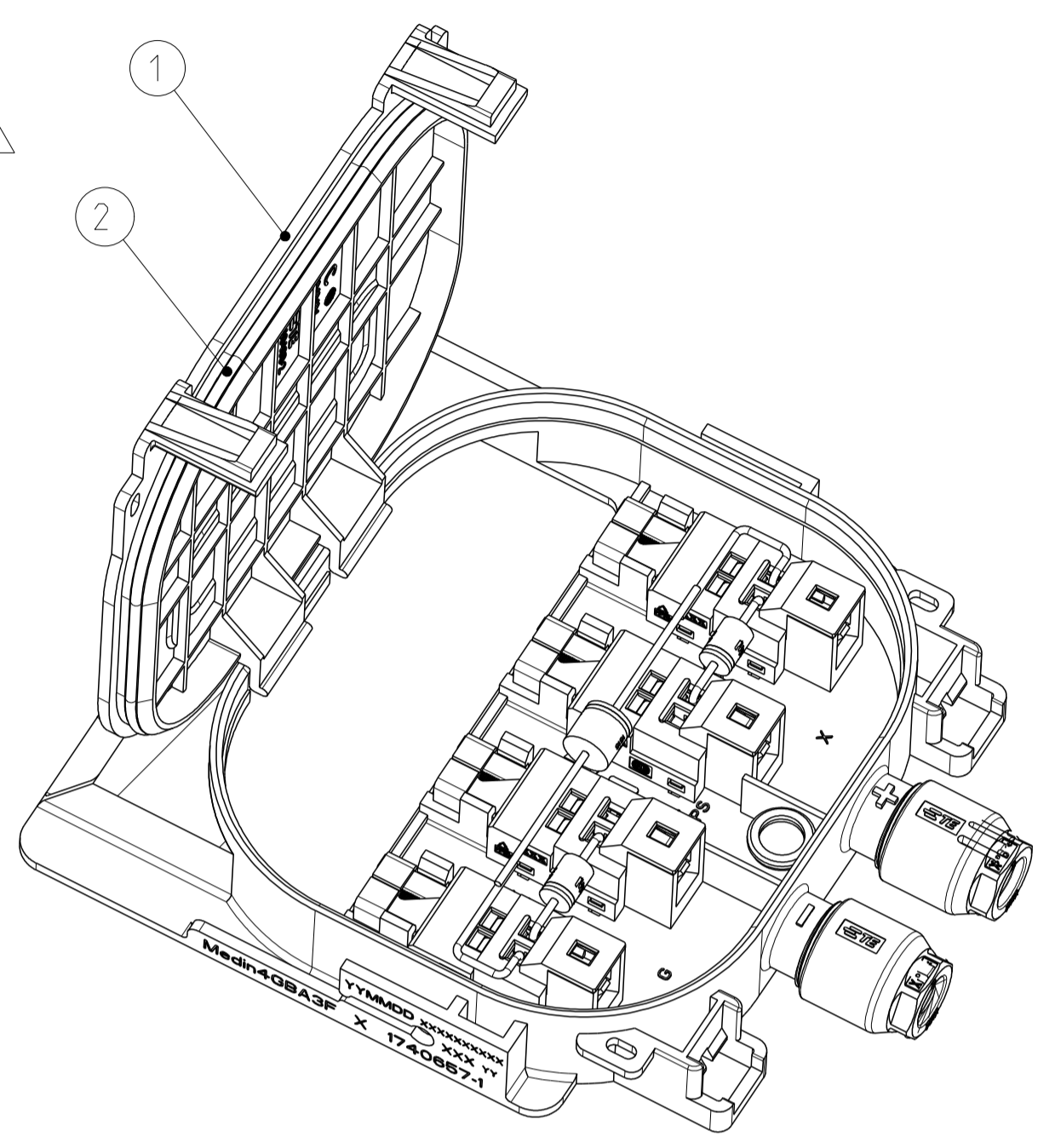

SCALE 1:1 / M 1:1

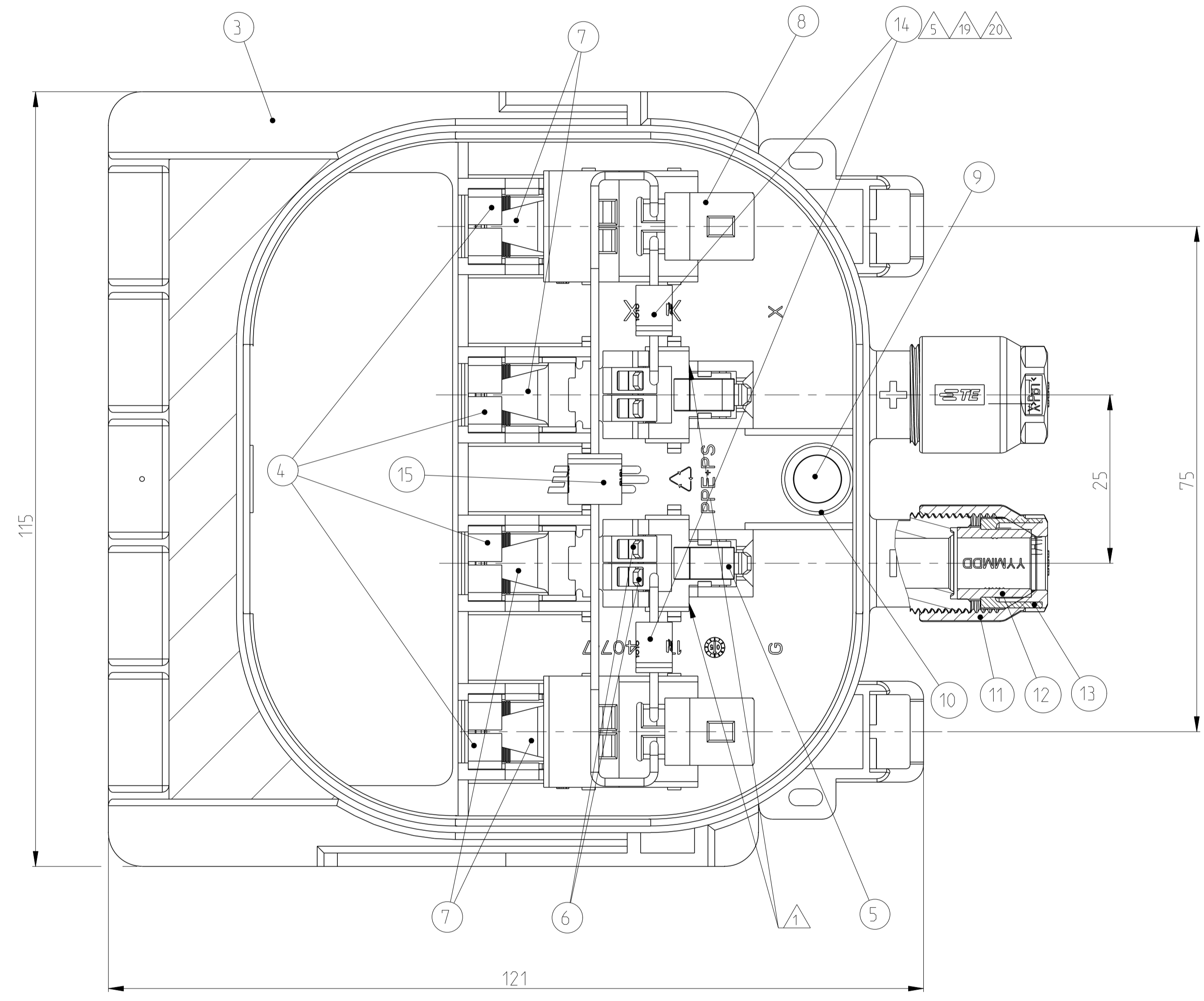
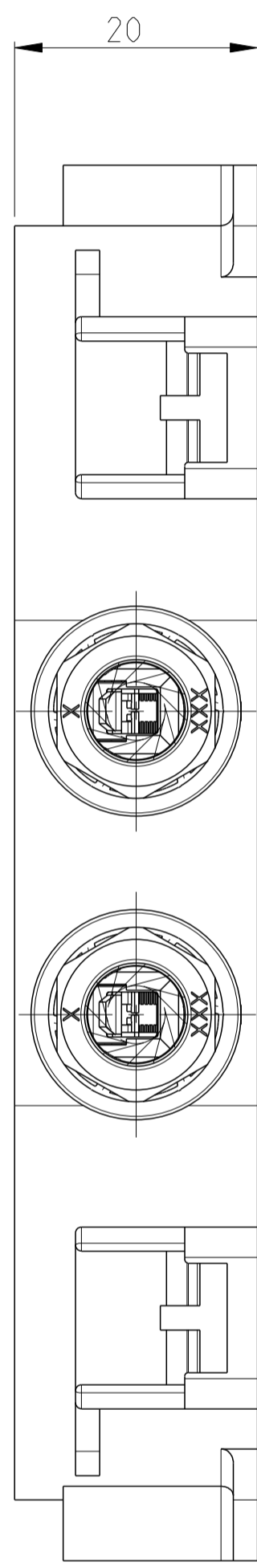

TABLE FOR MODEL CODE  
 TABELLE FÜR TYPENSCHLÜSSEL

PART NUMBER TEILNUMMER	MODEL CODE TYPENSCHLÜSSEL	I <sub>SCmax</sub>	
1740657-1	Medin4GBA3F	8.5 A	
1740657-2	Medin4GBAZZ	--	
1740657-3	Medin4GAA3F	8.5A	OBSOLETE
1740657-4	Medin4GAN3F	8.5A	OBSOLETE
1740657-5	Medin4GAN3F	8.5A	OBSOLETE

1740657-5	1740657-4	1740657-3	1740657-2	1740657-1	ITEM-NO. POS.	DESCRIPTION BENENNUNG	SURFACE OBERFLÄCHE	MATERIAL
1	1	1	1	1	21	SOLAR CABLE 4mm <sup>2</sup> / 12AWG, ZHSCG SOLARKABEL 4mm <sup>2</sup> / 12AWG, ZHSCG	RED ROT	-
1	1	1	1	1	20	CONNECTOR NEUTRAL, PIN STECKVERBINDER NEUTRAL, STIFT	-	-
1	1	1	1	1	19	CONNECTOR MINUS, SOCKET STECKVERBINDER MINUS, BUCHSE	-	-
1	2	1	1	1	18	SOLAR CABLE 4mm <sup>2</sup> / 12AWG, ZHSCG SOLARKABEL 4mm <sup>2</sup> / 12AWG, ZHSCG	BLACK SCHWARZ	-
1	1	1	1	1	17	BYPASS DIODE TYPE: SL1515 WITH WELDED LEGS BYPASS DIODE TYP. SL1515 MIT ANGESCHWISSENEN BEINCHEN	-	-
1	1	1	1	1	16	SOLAR MODULE BOX LOWER PART SOLAR-MODUL-BOX UNTERTEIL	BLACK SCHWARZ	PPE+PS
1	1	1	1	1	15	BYPASS DIODE TYPE: SL1515 WITH WELDED LEGS BYPASS DIODE TYP. SL1515 MIT ANGESCHWISSENEN BEINCHEN	-	-
2	2	2	2	2	14	BYPASS DIODE TYPE: SL1010 BYPASS DIODE TYP. SL1010	-	-
2	2	2	2	2	13	PINCH RING KLEMMKORB	BLACK SCHWARZ	PA
2	2	2	2	2	12	SEAL DICHTUNG	BLACK SCHWARZ	PP/EPDM
2	2	2	2	2	11	CABLE SCREW JOINT KABELVERBINDER	BLACK SCHWARZ	PBT
1	1	1	1	1	10	RING FOR ULTRASONIC WELDING RING FÜR ULTRASCHALLSCHWEISSEN	BLACK SCHWARZ	PPE+PS
1	1	1	1	1	9	MEMBRANE VENTS MEMBRANE	WHITE WEISS	GORE
4	4	4	4	4	8	SHROUDING COVER ABDECKHAUBE	BLACK SCHWARZ	PEI
4	4	4	4	4	7	FOIL SPRING FOLLENFEDER	PLAIN BLANK	STAINLESS STEEL ROSTFREIER STAHL
8	8	8	8	8	6	TE SPRING CLAMP WITH ANTI OVERSTRESS TE-KÄFIGZUFEDER MIT OBERDEHNFEDER	PLAIN BLANK	STAINLESS STEEL ROSTFREIER STAHL
2	2	2	2	2	5	TE SPRING CLAMP WITH ANTI OVERSTRESS TE-KÄFIGZUFEDER MIT OBERDEHNSCHUTZ	PLAIN BLANK	STAINLESS STEEL ROSTFREIER STAHL
4	4	4	4	4	4	CONTACT RAIL STROMSCHIENE	TIN HOT DIPPED FEUERVERZINKT	CUSn
1	1	1	1	1	3	SOLARLOK MODULE BOX 4 CONTACT RAILS, LOWER PART SOLARLOK-MODUL-BOX 4 STROMSCHIENEN, UNTERTEIL	BLACK SCHWARZ	PPE+PS
1	1	1	1	1	2	O-RING O-RING	RED ROT	SILICONE SILIKON
1	1	1	1	1	1	SOLAR MODULE BOX COVER SOLAR-MODUL-BOX-DECKEL	BLACK SCHWARZ	PPE+PS

ORDER-NO.  
BESTELL-NR.

-1 AS SHOWN  
-1 WIE GEZEICHNET

THIS DRAWING IS A CONTROLLED DOCUMENT. DWG: J.ZAPF 10MAR2006  
 CHG: H.SCHERER 10MAR2006  
 APVD: G.FELOMEIER 10MAR2006

DIMENSIONS: MASSENMAßEN (mm)  
 TOLERANCES UNLESS OTHERWISE SPECIFIED: ALLGEMEINTOLERANZEN  
 0 PLC ±0.5  
 1 PLC ±  
 2 PLC ±  
 3 PLC ±  
 4 PLC ±  
 ANGLES/SHARP CORNERS: 45°/90°  
 FINISH/SURFACE: -

MATERIAL: -

WEIGHT: -  
 GEWICHT: -

CUSTOMER DRAWING / KUNDENZEICHNUNG

SCALE: MASSSTAB 1:1  
 SHEET: BLATT 1  
 OF: VON 6

RESTRICTED TO: NUR FÜR -

STE TE Connectivity  
 NAME: SOLAR MODULE BOX ASSY, 4 CONTACT RAILS  
 SOLAR-MODUL-BOX ASSY, 4 STROMSCHIENEN  
 SIZE: A1  
 CAGE CODE: 00779  
 DRAWING NO.: 1740657  
 SHEET NO.: 1  
 REV: K2

LOC	DIST	REVISIONS				
		P	LTH	DATE	OWN	APVD
A1	-	-	SEE SHEET 1	-	-	-

- △ SHROUDING COVER ITEM NO. 8 NOT SHOWN
- △ COVER NOT ASSEMBLED WITH LOWER PART. ENCLOSE LOOSELY
- △ PART NUMBER
- △ PRODUCTION DATE ( YYMMDD )
- △ DIODE ACCORDING TO SPECIFICATION 108-94045-1
- △ DIODE ACCORDING TO SPECIFICATION 108-94046-1
- 7 TOTAL HEIGHT WITH CLOSED COVER 22mm
- △ MANUFACTURING LOCATION CODE
- △ DIODE SL1110 ACC. SPEC. 108-94119 OR SL1110B ACC. SPEC. 108-2444 CAN BE ALTERNATIVELY USED
- △ ONLY DIODES OF THE SAME TYPE RESP. DESIGNATION ARE PERMITTED FOR USE IN ONE AND THE SAME SOLAR BOX. ONLY SOLARLOK BOXES WITH THE SAME DIODES ARE PERMITTED TO PACK IN ONE AND THE SAME CORRUGATED SHIPPING BOX.
- △ MARK FOR DIODE TYPE, ADDED WITH LASER PRINTER OR MATRIX PRINTER:  
LEAVE BLANK FOR DIODE SL1010  
A FOR DIODE SL1110  
B FOR DIODE SL1110B
- △ MODEL CODE ACCORDING TE-SPEC. 404-74000-1
- △ CONSECUTIVE SERIAL NUMBER
- △ TEST EQUIPMENT NUMBER
- △ I<sub>SCmax</sub> ACC. IEC 61215 ED. 2.0, SECTION 10.18



- △ ABDECKHAUBE POS. 8 NICHT DARGESTELLT
- △ DECKEL NICHT MIT UNTERTEIL MONTIERT. LOSE BEIGELEGT.
- △ TEILENUMMER
- △ FERTIGUNGSDATUM ( YYMMDD )
- △ DIODE GEMÄSS SPEZIFIKATION 108-94045-1
- △ DIODE GEMÄSS SPEZIFIKATION 108-94046-1
- 7 GESAMTHÖHE MIT GESCHLOSSENEM DECKEL 22mm
- △ FERTIGUNGSSTANDORT-CODE
- △ DIODE SL1110 GEMÄSS SPEC. 108-94119 ODER SL1110B GEMÄSS SPEZ. 108-2444 KÖNNEN ALTERNATIV VERWENDET WERDEN.
- △ NUR DIODEN GLEICHEN TYPES BZW. BEZEICHNUNG DÜRFEN IN EIN UND DERSELBEN SOLARLOK BOX EINGESETZT WERDEN. NUR SOLARLOK BOXEN MIT DER GLEICHEN DIODE DÜRFEN IN EIN UND DEMSELBEN VERSANDKARTON VERPACKT WERDEN.
- △ KENNZEICHEN FÜR DIODENTYP. MIT LASERDRUCKER ODER NADELDRUCKER AUFGEBRACHT. OHNE KENNZEICHEN FÜR DIODE SL1010  
A FÜR DIODE SL1110  
B FÜR DIODE SL1110B
- △ TYPENSCHLÜSSEL NACH TE-SPEZIFIKATION 404-74000-2
- △ FORTLAUFENDE SERIENUMMER
- △ PRÜFGERÄTE-NUMMER
- △ I<sub>SCmax</sub> GEMÄSS IEC 61215 ED. 2.0, ABSCHNITT 10.18

MOUNTING INSTRUCTION

- FOR COVER, ASSY:
1. MOUNT COVER ITEM NO. 1 AND 2 INTO THE LOWER PART ITEM NO. 3 OR ITEM NO. 16 AND CLOSE IT. ( LATCH SNAP IN ).
  2. RE-OPEN: PUT IN MARKED OPENING △ SCREWDRIVER 3mm AND MOVE LATCH UNTIL LOCKING LATCH FREE THE COVER.  
OPEN COVER ITEM NO. 1 AND 2 AND PUT IN LATERAL RETAINING SLOT △

MONTAGEANWEISUNG

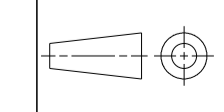
- FÜR DECKEL, ASSY:
1. DECKEL POS. 1 UND 2 IN DAS UNTERTEIL POS. 3 BZW. POS. 16 EINHÄNGEN UND SCHLIESSEN. ( LASCHE RASTET EIN ).
  2. ÖFFNEN: SCHRAUBENDREHER 3mm IN MARKIERTE ÖFFNUNG △ EINSTECKEN UND LASCHE BEWEGEN BIS RASTHAKEN DEN DECKEL FREI GIBT.  
DECKEL POS. 1 UND 2 ÖFFNEN UND IN SEITLICHEN HALTESCHLITZ △ EINSETZEN

THIS DRAWING IS A CONTROLLED DOCUMENT.		OWN J.ZAPF 10MAR2006		
DIMENSIONS: mm		CHK H.SCHERER 10MAR2006		
TOLERANCES UNLESS OTHERWISE SPECIFIED:		APVD G.FEILMEIER 10MAR2006	NAME SOLAR MODULE BOX ASSY, 4 CONTACT RAILS SOLAR MODUL BOX ASSY, 4 STROMSCHIENEN	
		PRODUCT SPEC 108-94038	SIZE A1	
		APPLICATION SPEC 114-18488	CAGE CODE 00779	
MATERIAL -		FINISH -	DRAWING NO 1740657	
		WEIGHT -	RESTRICTED TO -	
		CUSTOMER DRAWING		SCALE 1:1
				SHEET 2 OF 6
				REV. K2

LOC	DIST	REV	DATE	BY	APPROV
A1	-				
PROJEKT NR. EGDMN5031		SEE SHEET 1			

VIEW WITH ASSEMBLED COVER  
ANSICHT MIT MONTIERTEM DECKEL

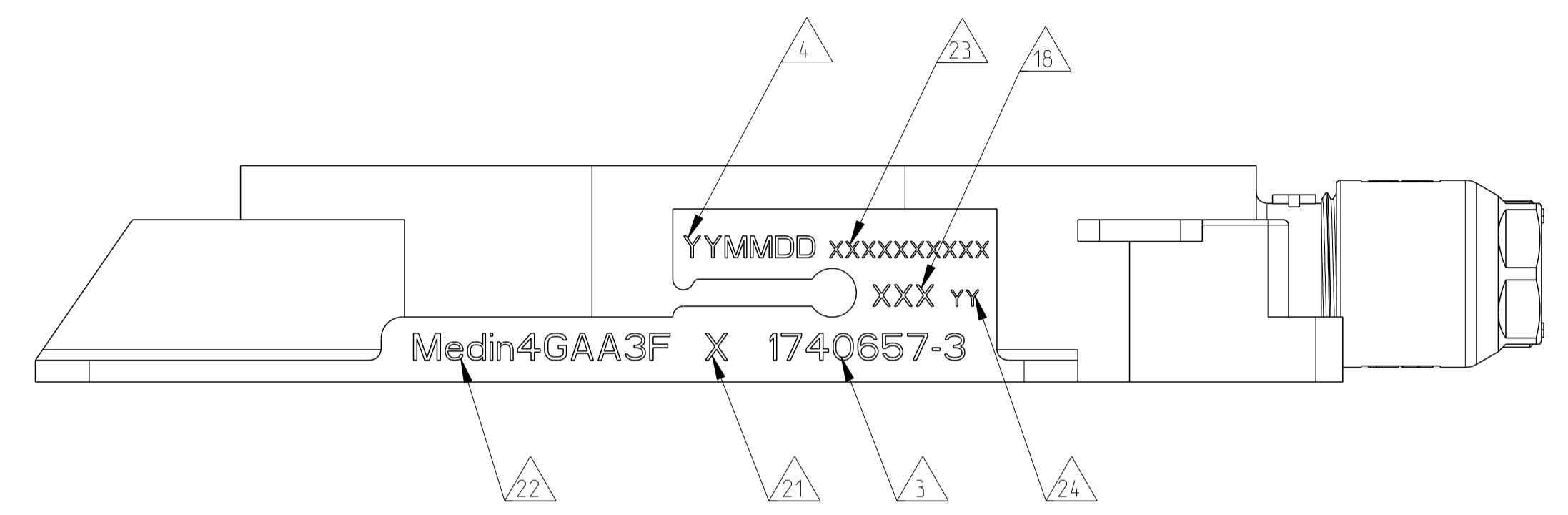

VIEW WITH ASSEMBLED COVER  
ANSICHT MIT MONTIERTEM DECKEL

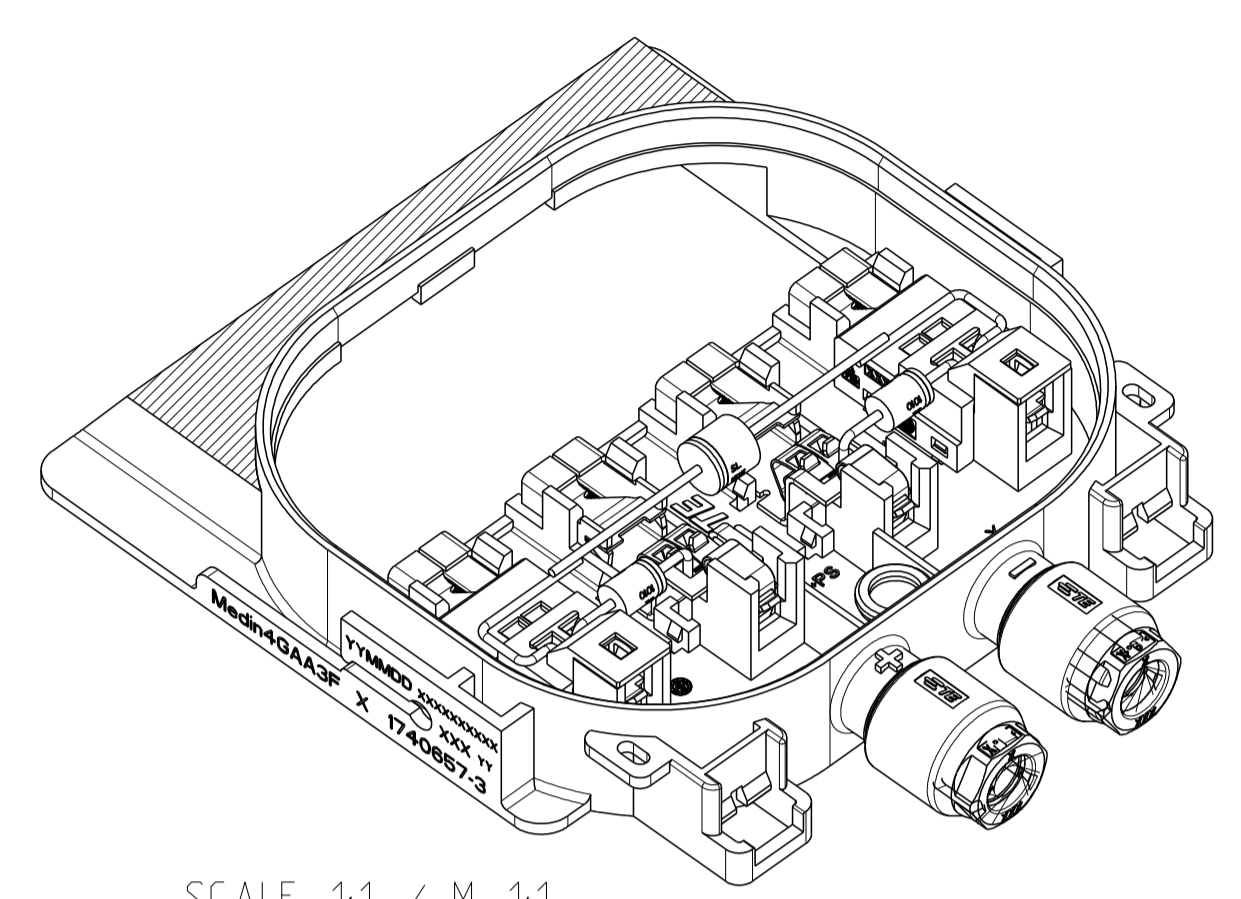

SCALE 1:1 / M 1:1

VIEW WITH ASSEMBLED COVER  
ANSICHT MIT MONTIERTEM DECKEL

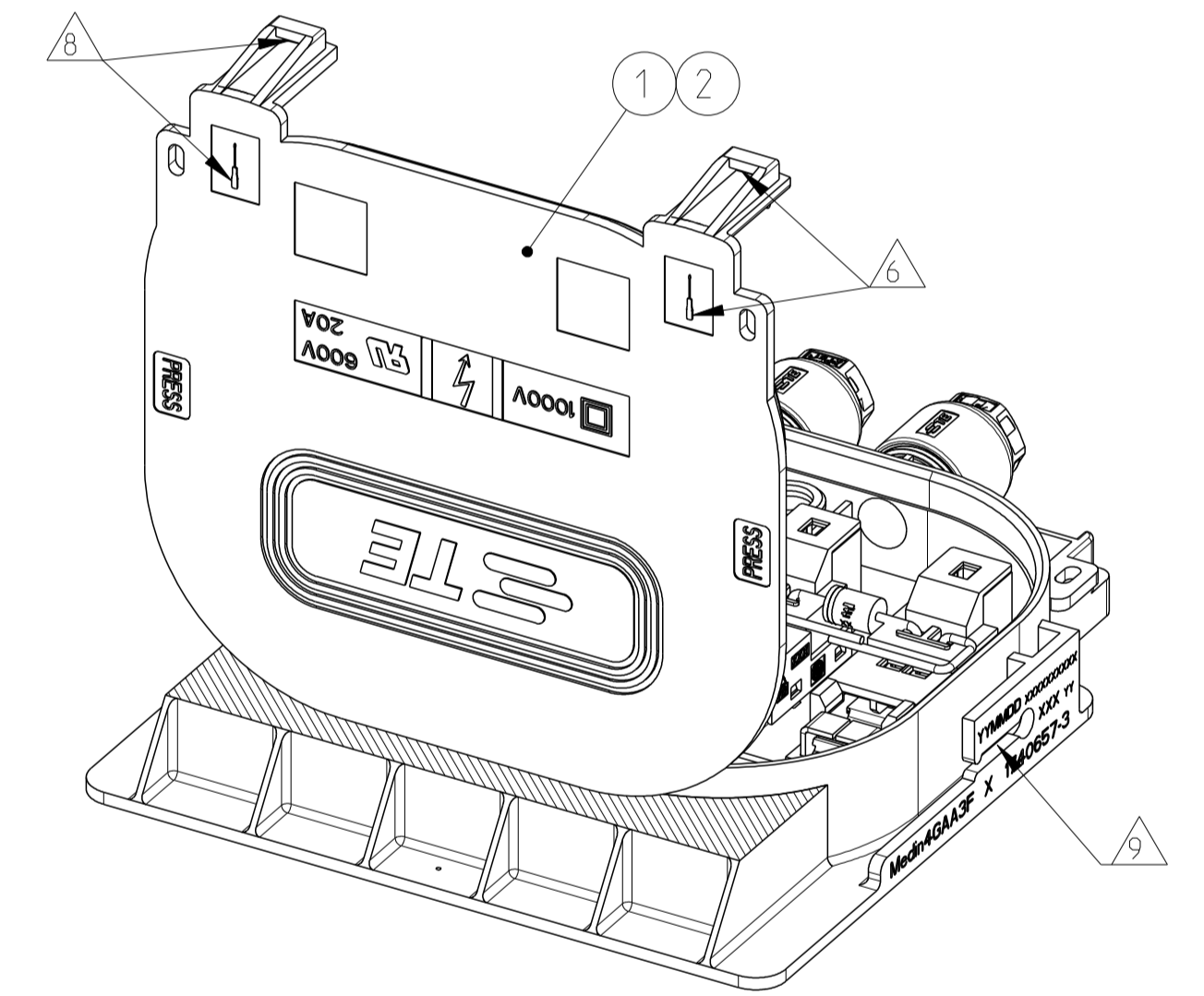

SCALE 1:1 / M 1:1

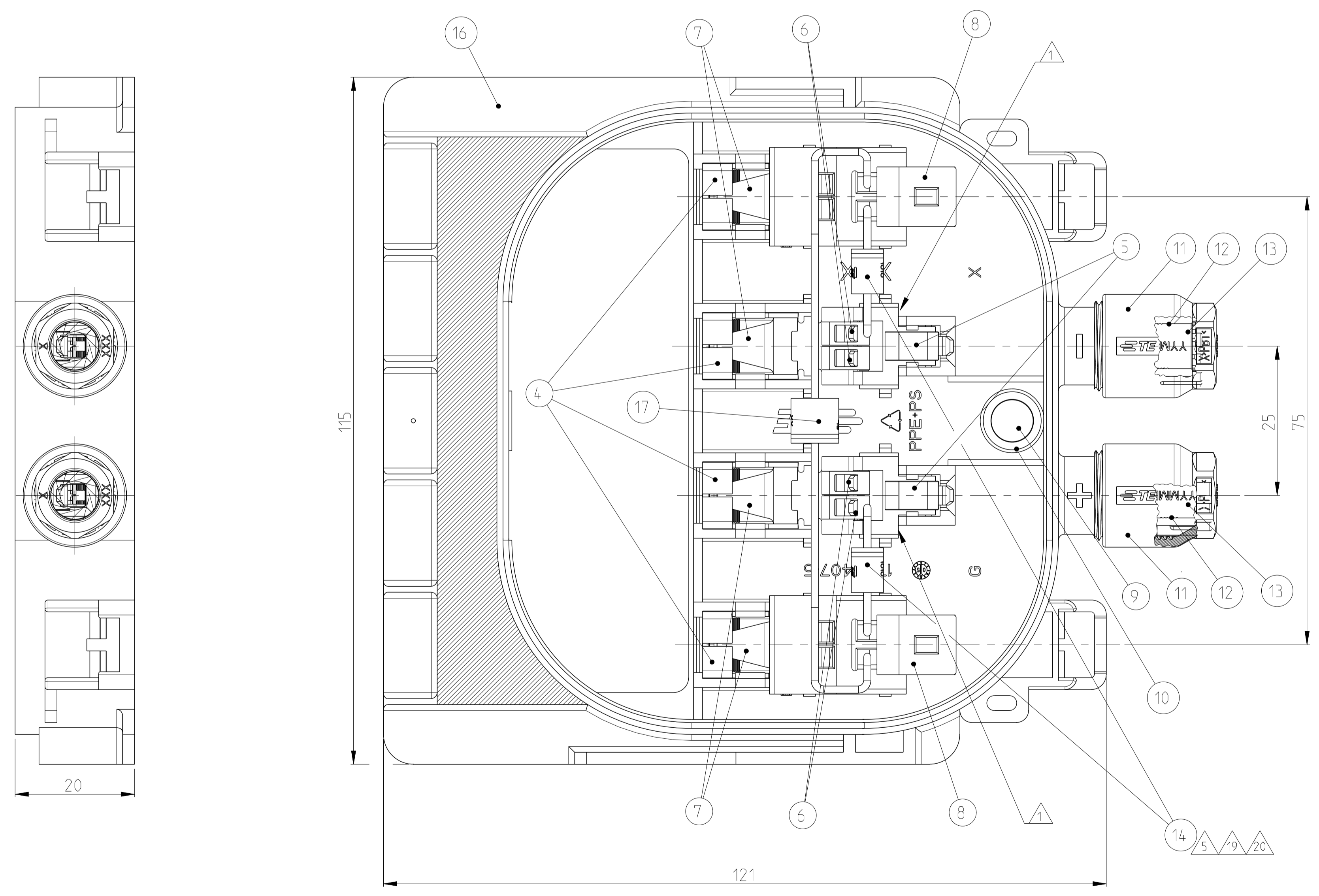

**OBSOLETE**

-3 AS SHOWN OBSOLETE  
-3 WIE GEZEICHNET

THIS DRAWING IS A CONTROLLED DOCUMENT.		OWN: J.ZAPF 10MAR2006	TE Connectivity
DIMENSIONS: MASSENHEITEN (mm)		CHK: H.SCHERER 10MAR2006	
TOLERANCES UNLESS OTHERWISE SPECIFIED: ALLGEMEINTOLERANZEN		APVD: G.FELOMEIER 10MAR2006	NAME: SOLAR MODULE BOX ASSY, 4 CONTACT RAILS SOLAR MODUL BOX ASSY, 4 STROMSCHIENEN
0 PLC ±0.5		PRODUCT SPEC: 108-94.038	
1 PLC ±		APPLICATION SPEC	SIZE: A1 CAGE CODE: 00779 DRAWING NO: 1740657
2 PLC ±		VERARBEITUNGSSPEZ: 114-104.000	
3 PLC ±		WEIGHT: -	RESTRICTED TO: - NUR FÜR: -
4 PLC ±		FINISH/BEFINNUNG/FARBE: -	
MATERIAL: -		CUSTOMER DRAWING	SCALE: 1:1 SHEET: 3 OF 6 REV: K2

LOC	DIST	REVISIONS		
A1	-	REV	DATE	APPROV
PROJECT NO.:	EGDMM5031	-	SEE SHEET 1	-

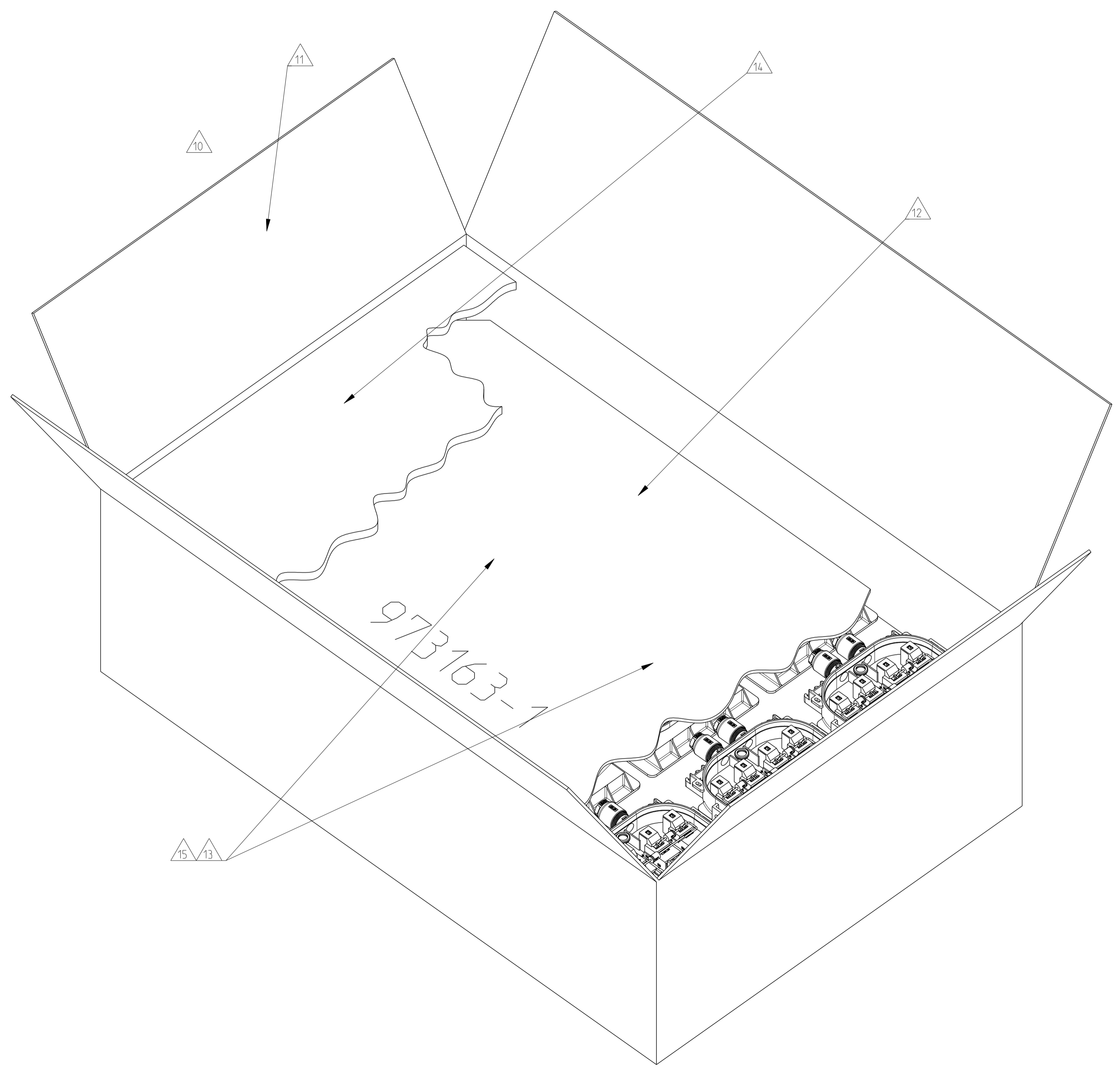

**10** PACKAGING PN 1740657-1, -2 AND -3: 60 PIECES SOLARLOK, 4 CONTACT RAILS PACKAGED IN CORRUGATED SHIPPING BOX **11**.  
 5 LAYERS OF 12 PIECES.  
 USED CORRUGATED LAYER PAD FOR INTERLAYER.  
 FIFTH LAYER SOLARLOK, 4 CONTACT RAILS COVERED WITH CORRUGATED LAYER PAD **12**.  
 60 PIECES SOLAR MODULE BOX COVER ASSY'S ITEM NO. 1 OF 30 PIECES BULK PACKAGED  
 IN ESD PLASTIC BAG **13** PUT ON THE FIFTH LAYER CORRUGATED LAYER PAD **14**.  
 ON TOP USED AS COVER PAPER CUSHION **15**.

**PACKAGING UNIT:** 60 PIECES  
**MINIMUM ORDER QUANTITY:** 60 PIECES

**15** SOLAR MODULE BOX COVER ASSY'S ITEM NO. 1 AND ITEM NO. 2 PACKAGED IN ESD PLASTIC BAG NOT SHOWN.

**10** VERPACKUNG PN 1740657-1, -2 UND -3: 60 STÜCK SOLARLOK, 4 STROMSCHIENEN VERPACKT IN VERSANDKARTON **11**.  
 5 LAGEN ZU JE 12 STÜCK.  
 ZWISCHENLAGENWELLPAPIER ALS ZWISCHENLAGE VERWENDET.  
 FÜNFTHE LAGE SOLARLOK, 4 STROMSCHIENEN MIT ZWISCHENLAGENWELLPAPIER **12** ABGEDECKT.  
 60 STÜCK SOLAR MODUL BOX DECKEL ASSY'S POS. 1 UND POS. 2 ZU JE 30 STÜCK ALS SCHÜTTGUT  
 IN ESD-KUNSTSTOFF-BEUTEL VERPACKT **13** AUF DIE FÜNFTHE LAGE ZWISCHENLAGENWELLPAPIER **14** GELEGT.  
 OBENAUF PAPIERPOLSTERKISSEN **15** ALS ABDECKUNG VERWENDET.

**VERPACKUNGSEINHEIT:** 60 STÜCK  
**MINDESTBESTELLMENGE:** 60 STÜCK

**15** SOLAR MODUL BOX DECKEL ASSY'S POS. 1 UND POS. 2 VERPACKT IN ESD-KUNSTSTOFF-BEUTEL NICHT DARGESTELLT.

THIS DRAWING IS A CONTROLLED DOCUMENT.		OWN	J.ZAPF	10MAR2006	<b>STE</b> TE Connectivity
DIMENSIONS: MASSENHEITEN (MM)		CHK	H.SCHNEIDER	10MAR2006	
TOLERANCES UNLESS OTHERWISE SPECIFIED: ALLGEMEINTOLERANZEN		APVD	G.FEIDMEIER	10MAR2006	NAME
0 PLC ±0.5		PRODUCT SPEC		SOLAR MODULE BOX ASSY, 4 CONTACT RAILS	
1 PLC ±		PRODUCT SPEC		SOLAR MODUL BOX ASSY, 4 STROMSCHIENEN	
2 PLC ±		APPLICATION SPEC		-	
3 PLC ±		VERARBEITUNGSSPEZ.		SIZE	A1
4 PLC ±		ANLEGE/SCHWINGEL		CAGE CODE	00779
FINISH/SCHWARZ/FARBE		WEIGHT		DRAWING NO.	1740657
-		BEWICHT		RESTRICTED TO	NUR FÜR
-		CUSTOMER DRAWING		SCALE	1:1
-		/KUNDENZEICHNUNG		SHEET	4
-		-		OF	6
-		-		REV	K2

VIEW WITH ASSEMBLED COVER  
 ANSICHT MIT MONTIERTEM DECKEL

LOC	DIST	REV	DATE	OWN	APVD
A1	-	-	-	-	-
PROJECT NO.: EGMW5031		SEE SHEET 1			

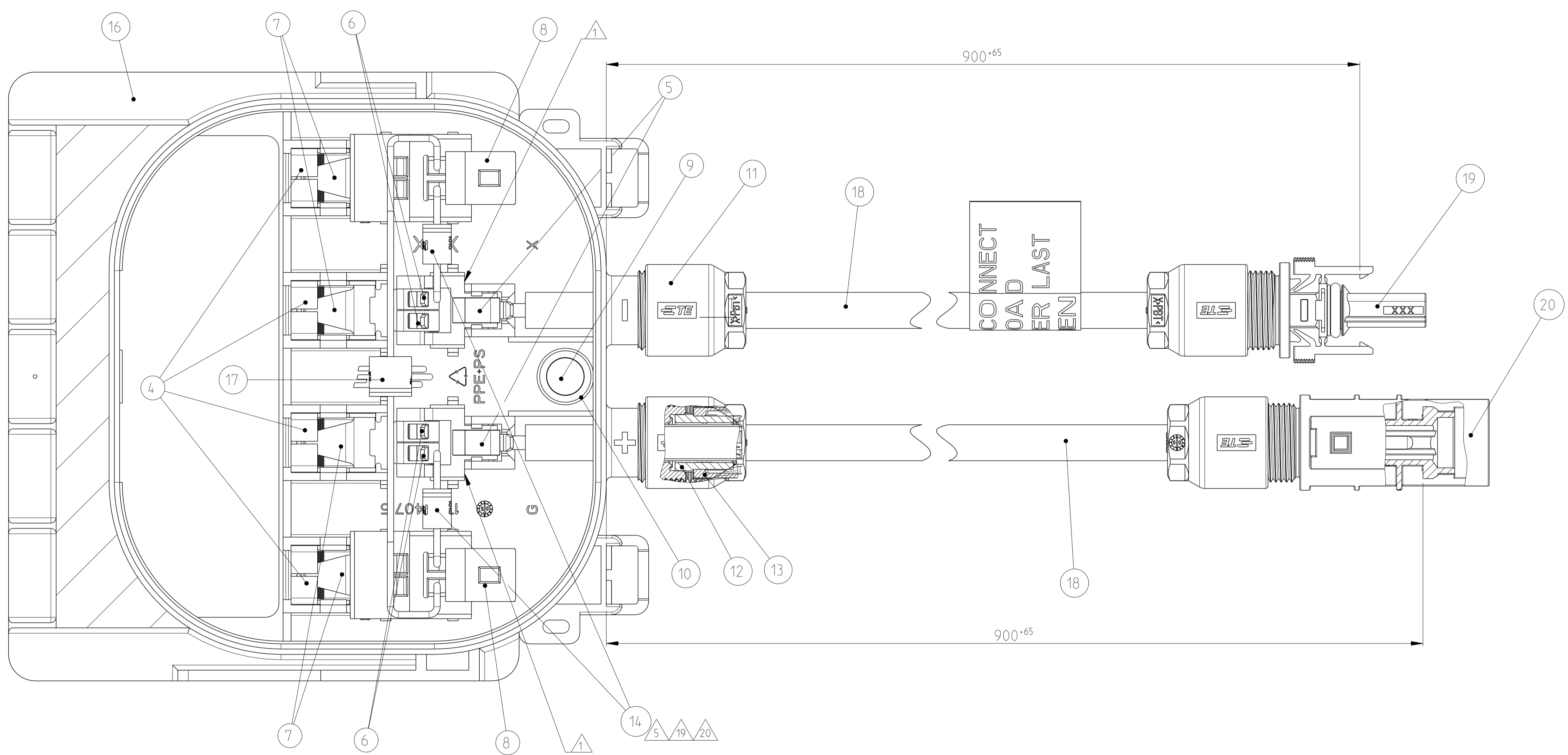
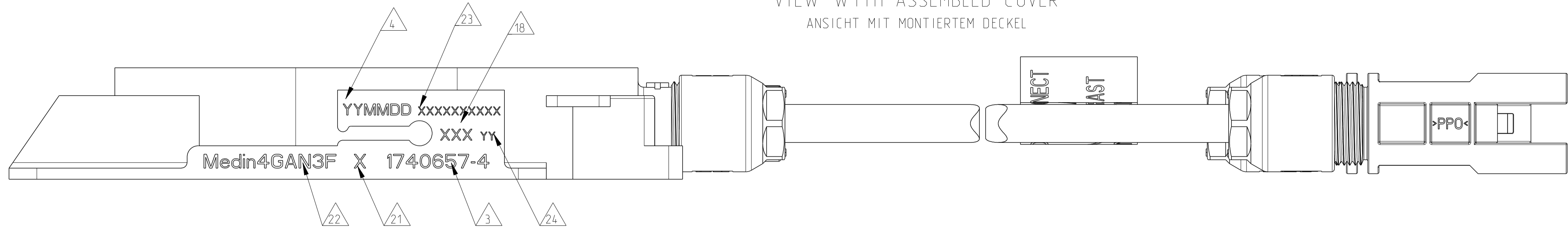

△ PACKAGING PN 1740657-4: 35 4 RAIL SOLARBOXES PACKAGED IN TWO ROWS OF 17 AND 18 BOXES ON TOP OF CORRUGATED LAYER PAD IN CORRUGATED SHIPPING BOX.  
 4 RAIL SOLARBOXES COVERED WITH CORRUGATED LAYER PAD.  
 35 PIECES SOLAR MODULE BOX COVER ASSY'S ITEM NO. 1 PACKED IN ESD PLASTIC BAG ON TOP OF CORRUGATED LAYER.  
 15 IN THE FIRST AND SECOND LEVEL, 5 IN THE THIRD LEVEL  
 ON TOP - USED AS COVER - PAPER CUSHION.

PACKAGING UNIT: 35 PIECES  
 MINIMUM ORDER QUANTITY: 35 PIECES

△ VERPACKUNG PN 1740657-4: 35 STÜCK 4 SCHIENIGE SOLARBOXEN ZWEIREIHIG MIT 17 UND 18 BOXEN VERPACKT AUF ZWISCHENLAGENWELLPAPIER IN VERSANDKARTON.  
 4 SCHIENIGE SOLARBOXEN MIT ZWISCHENLAGENWELLPAPIER ABGEDECKT.  
 35 STÜCK SOLAR MODUL BOX DECKEL ASSY'S ITEM NO. 1 AUF ZWISCHENLAGENWELLPAPIER GEPACKT IN ESD-KUNSTSTOFF-BEUTEL VERPACKT AUF DIE LETZTE LAGE  
 15 IN DER ERSTEN UND ZWEITEN LAGE, 5 IN DER DRITTEN LAGE.  
 OBENAUF - ALS ABDECKUNG VERWENDET - PAPIERPOLSTERKISSEN.

VERPACKUNGSEINHEIT: 35 STÜCK  
 MINDESTBESTELLMENGE: 35 STÜCK

**OBSOLETE**

-4 AS SHOWN  
 -4 WIE GEZEICHNET OBSOLETE

THIS DRAWING IS A CONTROLLED DOCUMENT.		OWN: J.ZAPF 10MAR2006	
DIMENSIONS: MASSENHEITEN (MM)		CHK: H.SCHERER 10MAR2006	
TOLERANCES UNLESS OTHERWISE SPECIFIED: ALLE DIMENSIONEN		APVD: G.FELOMEIER 10MAR2006	NAME: SOLAR MODULE BOX ASSY, 4 CONTACT RAILS SOLAR MODUL BOX ASSY, 4 STROMSCHIENEN
0 PLC ±0.5		PRODUCT SPEC: 108-94.038	
1 PLC ±		APPLICATION SPEC:	SIZE: A1
2 PLC ±		VERARBEITUNGSPEZ. TIT-104-00	CAGE CODE: 00779
3 PLC ±		FINISH/SCHWARZ/FARBE	DRAWING NO: 1740657
4 PLC ±		WEIGHT	RESTRICTED TO NUR FÜR
5 PLC ±		GEWICHT	SCALE: 1:1
MATERIAL		CUSTOMER DRAWING	SHEET 5 OF 6
			REV: K2

VIEW WITH ASSEMBLED COVER  
 ANSICHT MIT MONTIERTEM DECKEL

LOC		DIST		REVISIONS			
PROJECT NO.	EGGMN05031	P	LTH	DESCRIPTION	DATE	OWN	APVD
		-	-	SEE SHEET 1	-	-	-

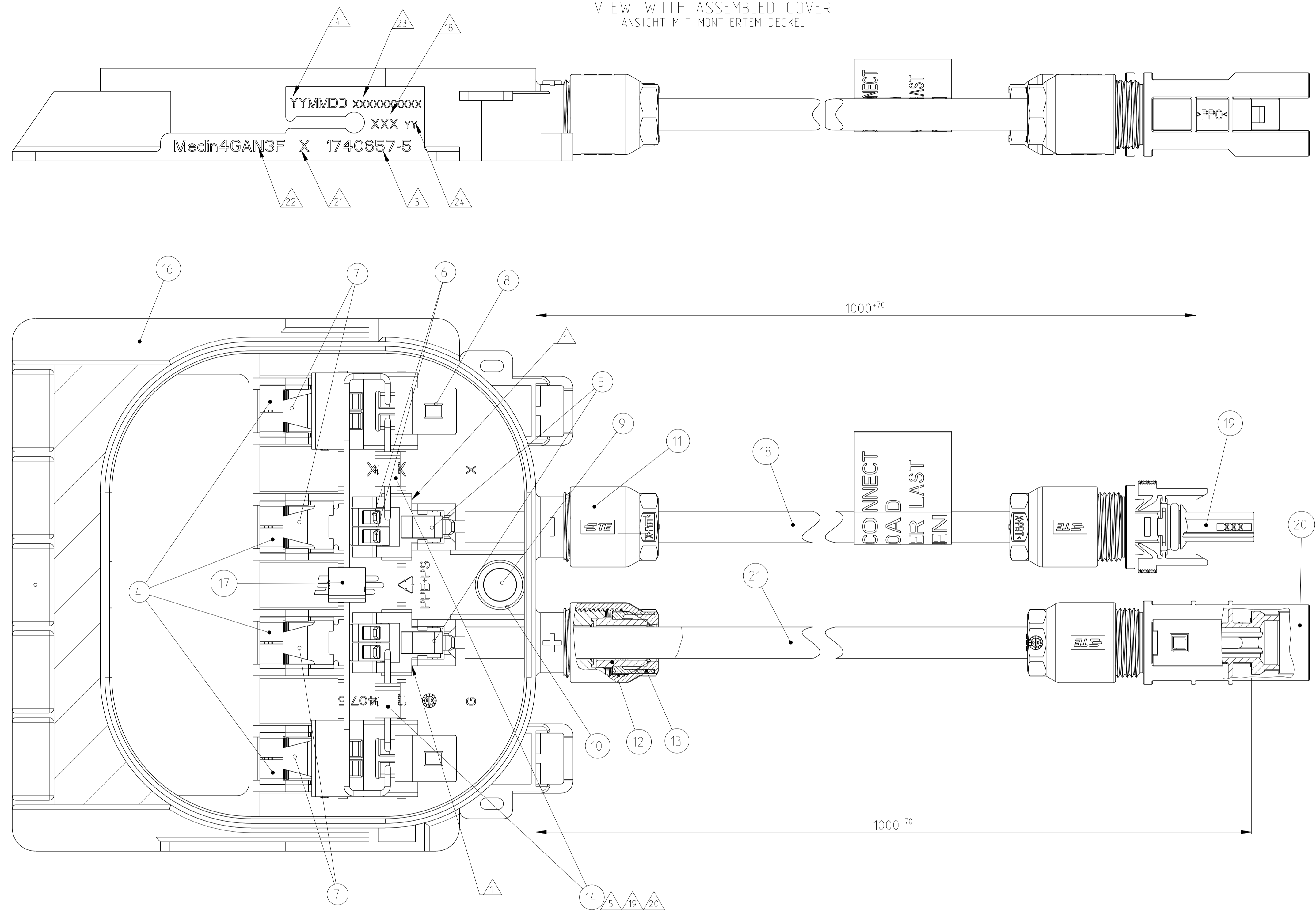

**17** PACKAGING PN 1740657-5: 35 4 RAIL SOLARBOXES PACKAGED IN TWO ROWS OF 17 AND 18 BOXES ON TOP OF CORRUGATED LAYER PAD IN CORRUGATED SHIPPING BOX.  
 4 RAIL SOLARBOXES COVERED WITH CORRUGATED LAYER PAD.  
 35 PIECES SOLAR MODULE BOX COVER ASSY'S ITEM NO. 1 PACKED IN ESD PLASTIC BAG ON TOP OF CORRUGATED LAYER.  
 15 IN THE FIRST AND SECOND LEVEL, 5 IN THE THIRD LEVEL  
 ON TOP - USED AS COVER - PAPER CUSHION.

PACKAGING UNIT: 35 PIECES  
 MINIMUM ORDER QUANTITY: 35 PIECES

**17** VERPACKUNG PN 1740657-5: 35 STÜCK 4 SCHIENIGE SOLARBOXEN ZWEIREIHIG MIT 17 UND 18 BOXEN VERPACKT AUF ZWISCHENLAGENWELLPAPIER IN VERSANDKARTON.  
 4 SCHIENIGE SOLARBOXEN MIT ZWISCHENLAGENWELLPAPIER ABGEDECKT.  
 35 STÜCK SOLAR MODUL BOX DECKEL ASSY'S ITEM NO. 1 AUF ZWISCHENLAGENWELLPAPIER GEPACKT IN ESD-KUNSTSTOFF-BEUTEL VERPACKT AUF DIE LETZTE LAGE  
 15 IN DER ERSTEN UND ZWEITEN LAGE, 5 IN DER DRITTEN LAGE.  
 OBENAUF - ALS ABDECKUNG VERWENDET - PAPIERPOLSTERKISSEN.

VERPACKUNGSEINHEIT: 35 STÜCK  
 MINDESTBESTELLMENGE: 35 STÜCK

**OBSOLETE**

-5 AS SHOWN  
 -5 WIE GEZEICHNET OBSOLETE

THIS DRAWING IS A CONTROLLED DOCUMENT.		OWN: J.ZAPF 10MAR2006	
DIMENSIONS: mm		CHK: H.SCHERER 10MAR2006	
TOLERANCES UNLESS OTHERWISE SPECIFIED:		APVD: G.FELOMEIER 10MAR2006	NAME: SOLAR MODULE BOX ASSY, 4 CONTACT RAILS SOLAR MODUL BOX ASSY, 4 STROMSCHIENEN
0 PLC ±0.5	1 PLC ±	PRODUCT SPEC	SIZE: A1
2 PLC ±	3 PLC ±	108-94038	CAGE CODE: 00779
4 PLC ±	ANGLES ±1°	APPLICATION SPEC	DRAWING NO: 1740657
MATERIAL: -	FINISH: -	114-18488	RESTRICTED TO: -
CUSTOMER DRAWING		WEIGHT: -	SCALE: 1:1
		SHEET: 6 OF 6	REV: K2

# Mouser Electronics

Authorized Distributor

Click to View Pricing, Inventory, Delivery & Lifecycle Information:

[TE Connectivity:](#)

[1740657-8](#)