

FUJITSU Component Connector

FCN-074B / 078B series

Card Edge Connector for DDR4 Memory Module

Discontinued

RoHS compliant

Overview

This is a 288-pin DIMM socket that conforms to JEDEC standards.

Features

- **Highly reliable contact**
Contact reliability with a module substrate is improved by a Fujitsu proprietary double-contact structure, which is resistant to dust and flux
- **Various terminal shapes to match with substrate design and mounting form**
One surface mount type, one press fit type, and three through-hole types having different terminal lengths are included in this lineup
- **Flame resistant UL94V-0**
Flame resistant UL94V-0 LCP resin is used for the housing insulating material
- **Typical applications**
DRAM-memory module connections for HPCs (servers, supercomputers), communication measurement apparatuses and office equipment



DDR4 DIMM socket

Item	Specification
Operating temperature range	-55°C to +85°C
Max. current rating	0.75A
Max. voltage rating	29VAC
Contact resistance	40mΩ maximum (10mA, 20mVDC)
Insulation resistance	1MΩ minimum (500VDC)
Dielectric withstanding voltage	500VAC for 1 minute
Substrate insertion force	126.4N less than

Item	Material, surface treatment	
Insulation material	LCP resing (UL94V-0)	
Conductor	Copper alloy	
Surface treatment	Contact	Gold plating (PAGOS)
	Terminal	Gold coat
Ejector	PA resin (UL94V-0)	
Metal fitting	Copper alloy (tin plating)	

■ Part numbers and dimensions

Part number	Terminal shape	Substrate thickness	Number of pins	Package format	Min. package unit	Min. shipment unit
FCN-074B288-G/0D	Through hole	1.6	288	Tray	40 pieces	200 pieces
FCN-074B288-G/1D		2.4	288		40 pieces	200 pieces
FCN-074B288-G/2D		3.2	288		40 pieces	200 pieces
FCN-078B288-G/0	Surface mount	-	288		40 pieces	200 pieces
FCN-074B288-G/0P	Press fit	1.6 min.	288		40 pieces	200 pieces

■ Dimensions

- Through-hole type FCN-074B288-G/□D
Memory module conforms to JEDEC MO-309)

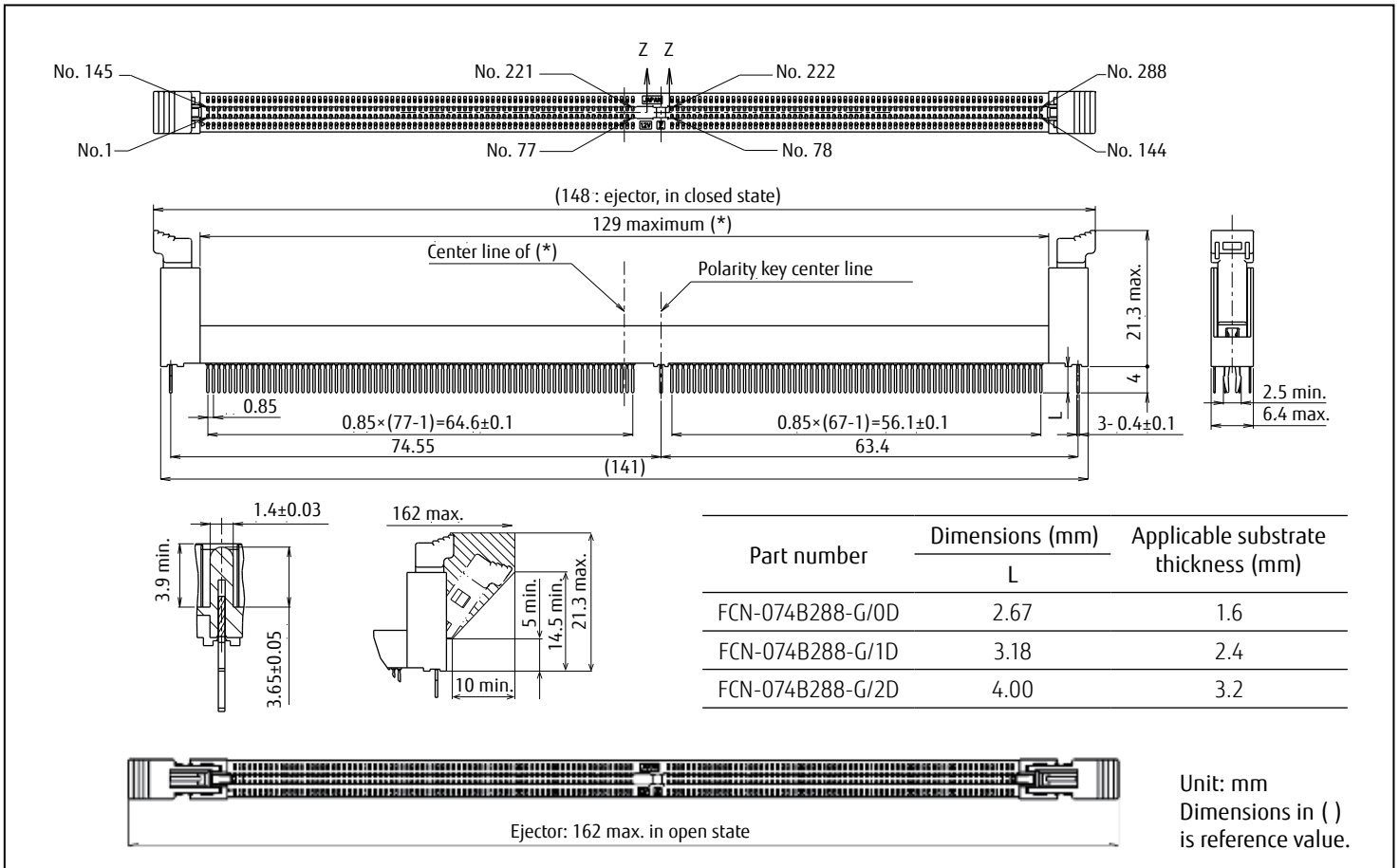

- Recommended printed circuit board (Top view)

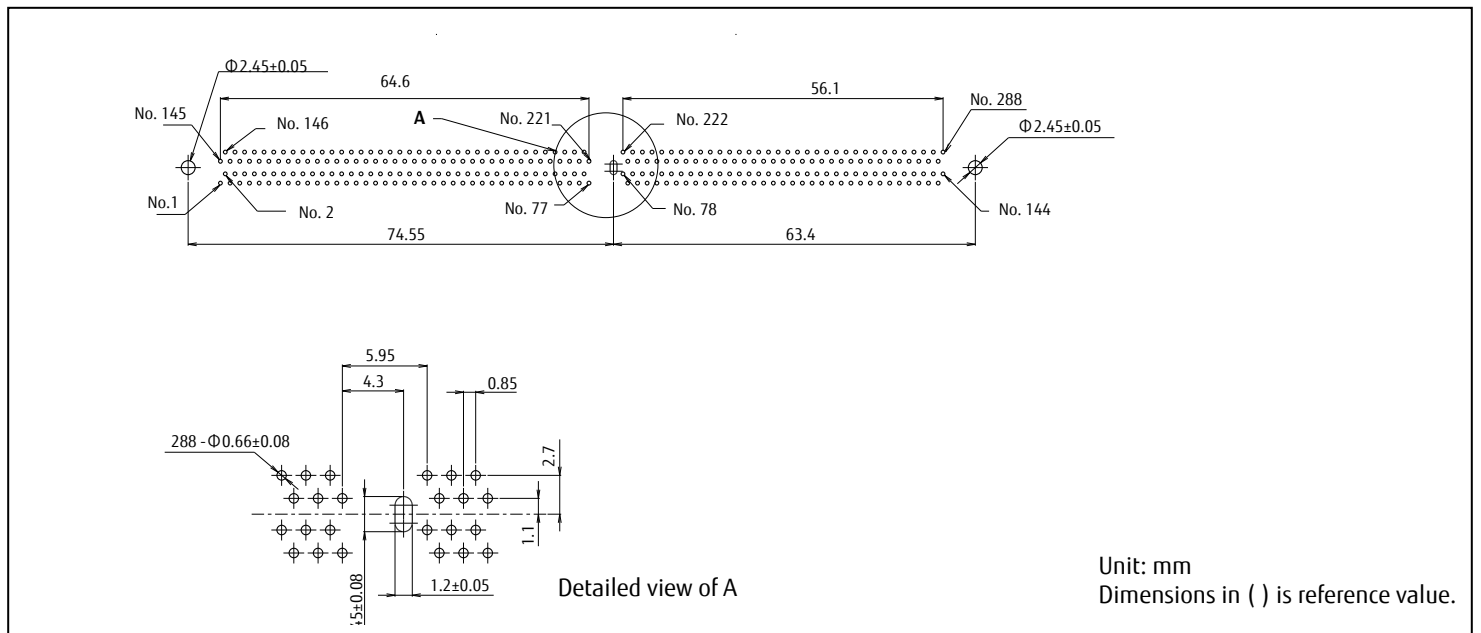

■ Dimensions

- Surface mount type FCN-078B288-G/0
Memory module conforms to JEDEC MO-309)

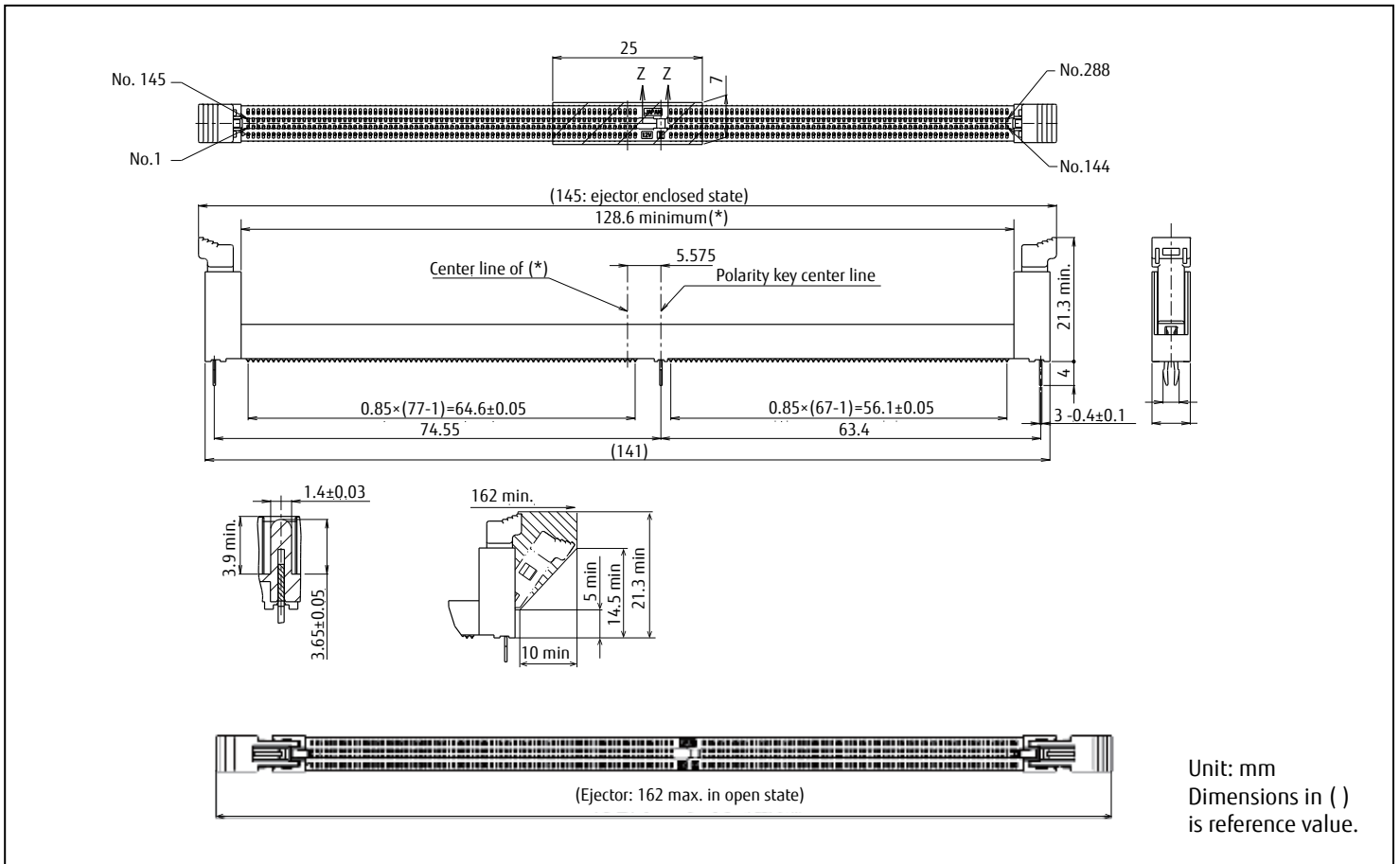

- Recommended printed circuit board pattern (Top view)

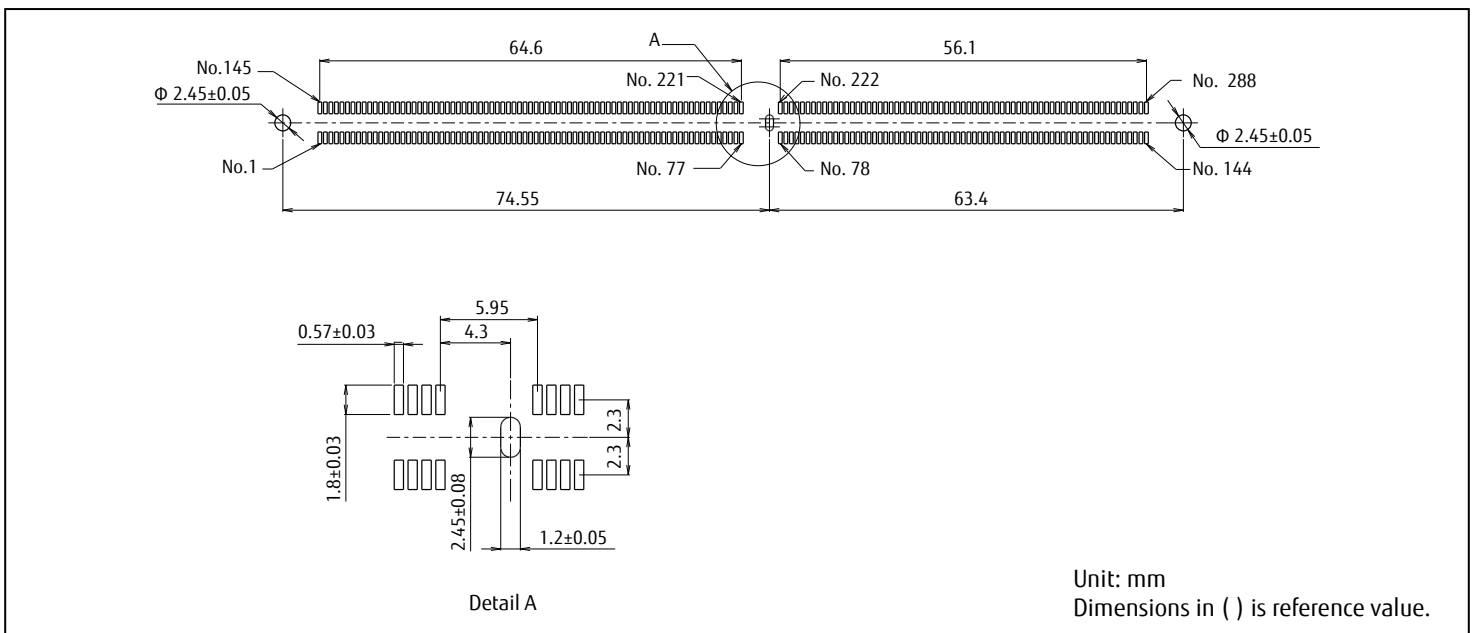

■ Dimensions

- Press fit type FCN-074B288-G/0P
Memory module conforms to JEDEC MO-309)

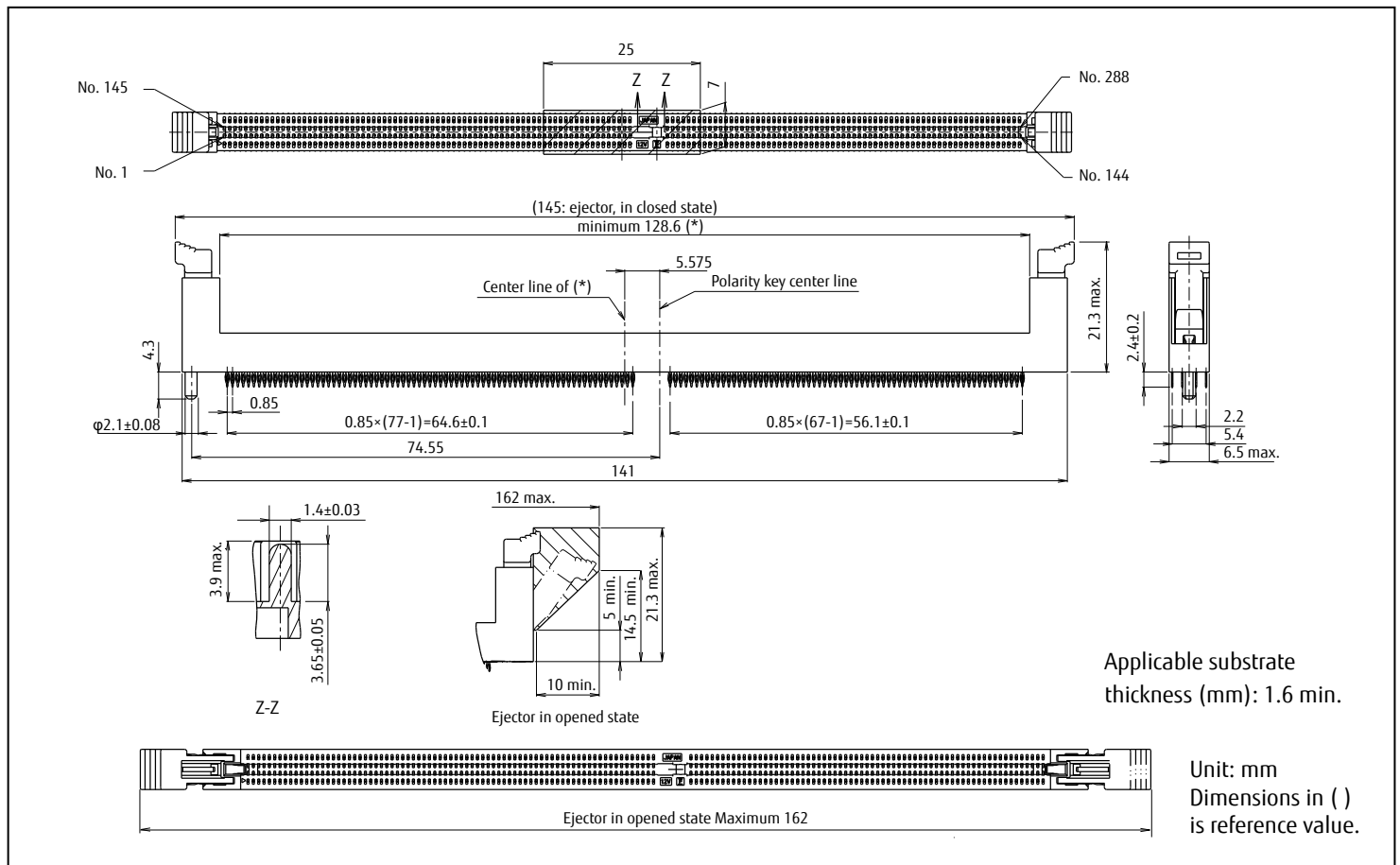

- Recommended printed circuit board pattern (Top view)

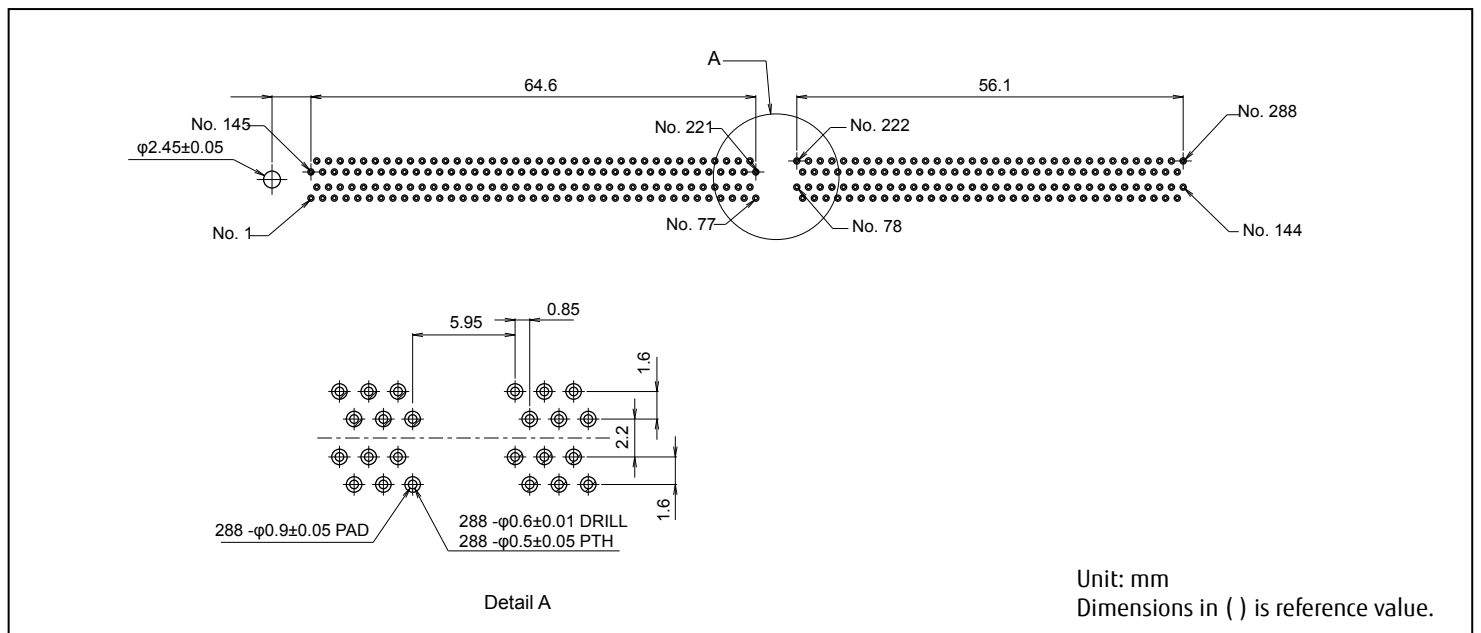

■ Recommended soldering conditions (surface mount type)

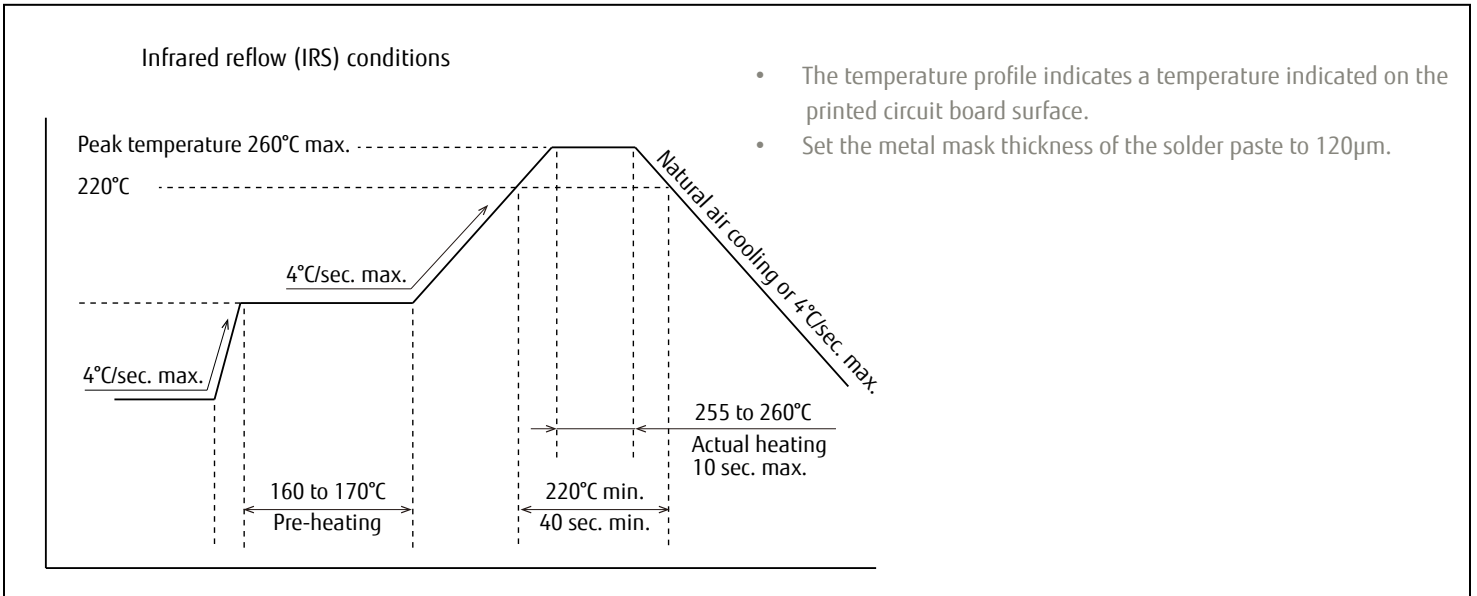

■ Reference: Recommended memory module terminal shape (applicable to both surface mount/through hole/press fit)

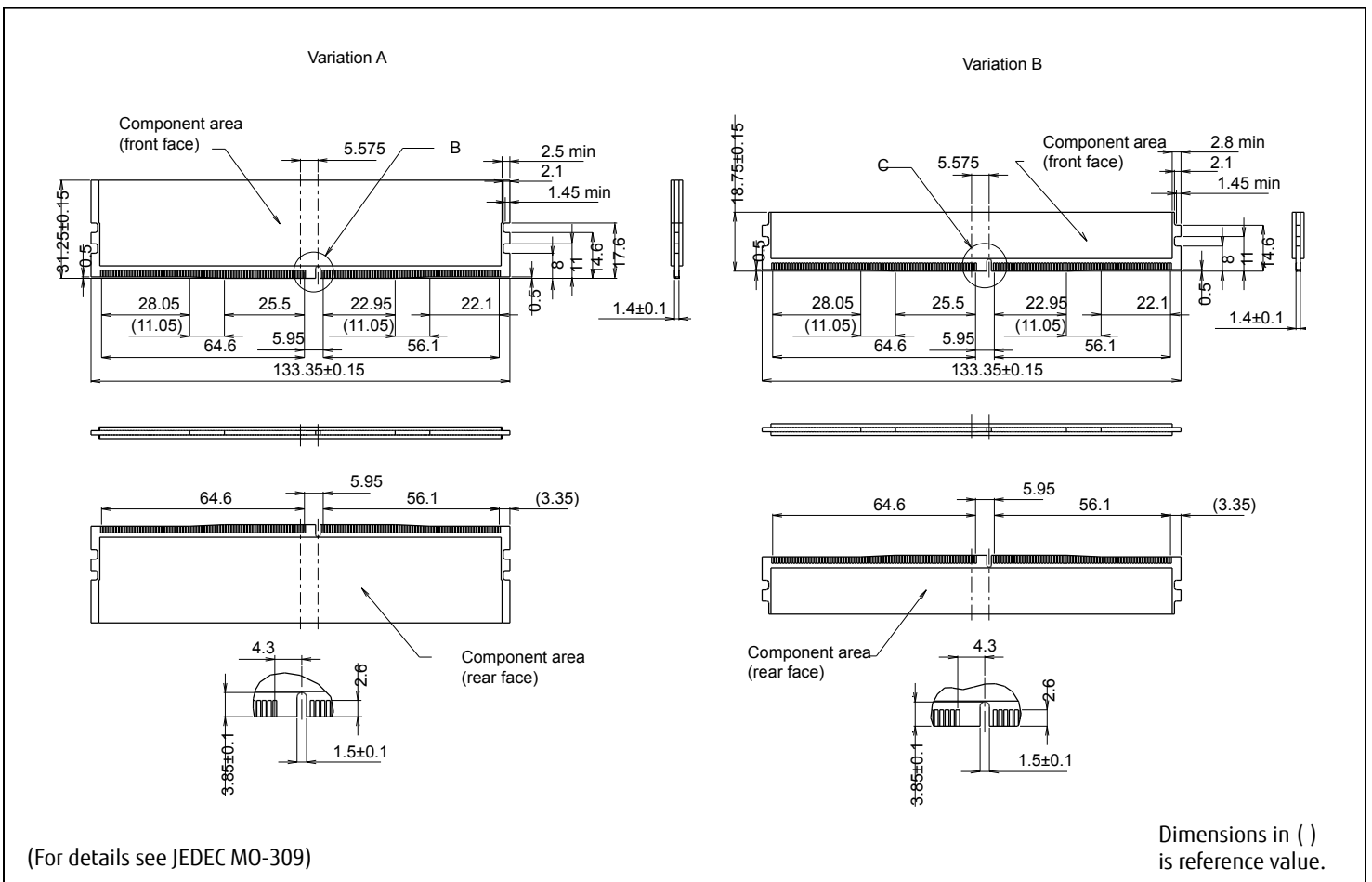

PAGOS is a trademark of Fujitsu Component Limited

Contact

Japan

FUJITSU COMPONENT LIMITED
Shinagawa Seaside Park Tower
12-4, Higashi-shinagawa 4-chome,
Tokyo 140 0002, Japan
Tel: (81-3) 3450-1681
Fax: (81-3) 3474-2385
Email: fcl-contact@cs.jp.fujitsu.com
Web: www.fujitsu.com/jp/group/fcl/en/

North and South America

FUJITSU COMPONENTS AMERICA, INC.
2290 North First Street, Suite 212
San Jose, CA 95131 U.S.A.
Tel: (1-408) 745-4900
Fax: (1-408) 745-4970
Email: components@us.fujitsu.com
Web: http://us.fujitsu.com/components/

Europe

FUJITSU COMPONENTS EUROPE B.V.
Diamantlaan 25
2132 WV Hoofddorp
Netherlands
Tel: (31-23) 5560910
Fax: (31-23) 5560950
Email: info@fceu.fujitsu.com
Web: emea.fujitsu.com/components/

Asia Pacific

FUJITSU COMPONENTS ASIA, Ltd.
102E Pasir Panjang Road
#01-01 Citilink Warehouse Complex,
Singapore 118529
Tel: (65) 6375-8560 / Fax: (65) 6273-3021
Email: fcal@sg.fujitsu.com
www.fujitsu.com/sg/products/devices/
components/

China

FUJITSU ELECTRONIC COMPONENTS
(SHANGHAI) CO., LTD.
Unit 4306, InterContinental Center
100 Yu Tong Road, Shanghai 200070, China
Tel: (86 21) 3253 0998 /Fax: (86 21) 3253 0997
Email: fcal@sg.fujitsu.com
www.fujitsu.com/sg/products/devices/
components/

Hong Kong

FUJITSU COMPONENTS HONG KONG Co., Ltd.
Room 06, 28/F, Greenfield Tower, Concordia
Plaza, No.1 Science Museum Road,
Tsim Sha Tsui East, Kowloon, Hong Kong
Tel: (852) 2881 8495 Fax: (852) 2894 9512
Email: fcal@sg.fujitsu.com
www.fujitsu.com/sg/products/devices/
components/

Korea

FUJITSU COMPONENTS KOREA, LTD.
Alpha Tower #403,
645 Sampyeong-dong,
Bundang-gu, Seongnam-si,
Gyeonggi-do, 13524 Korea
Tel: (82 31) 708-7108
Fax: (82 31) 709-7108
Email: fcal@sg.fujitsu.com
www.fujitsu.com/sg/products/
devices/components/

Copyright

All trademarks or registered trademarks are the property of their respective owners. Fujitsu Components America or its affiliates do not warrant that the content of datasheet is error free. In a continuing effort to improve our products Fujitsu Components America, Inc. or its affiliates reserve the right to change specifications/datasheets without prior notice. Copyright ©2017 Fujitsu Components America, Inc. All rights reserved. Revised November 7, 2017.

Mouser Electronics

Authorized Distributor

Click to View Pricing, Inventory, Delivery & Lifecycle Information:

Fujitsu:

[FCN-078B288-G/0](#) [FCN-074B288-G/0P](#) [FCN-074B288-G/0D](#) [FCN-074B288-G/1D](#) [FCN-074B288-G/2D](#)