

REV.	DATE	DESCRIPTION
NC	07/19/05	INITIAL RELEASE

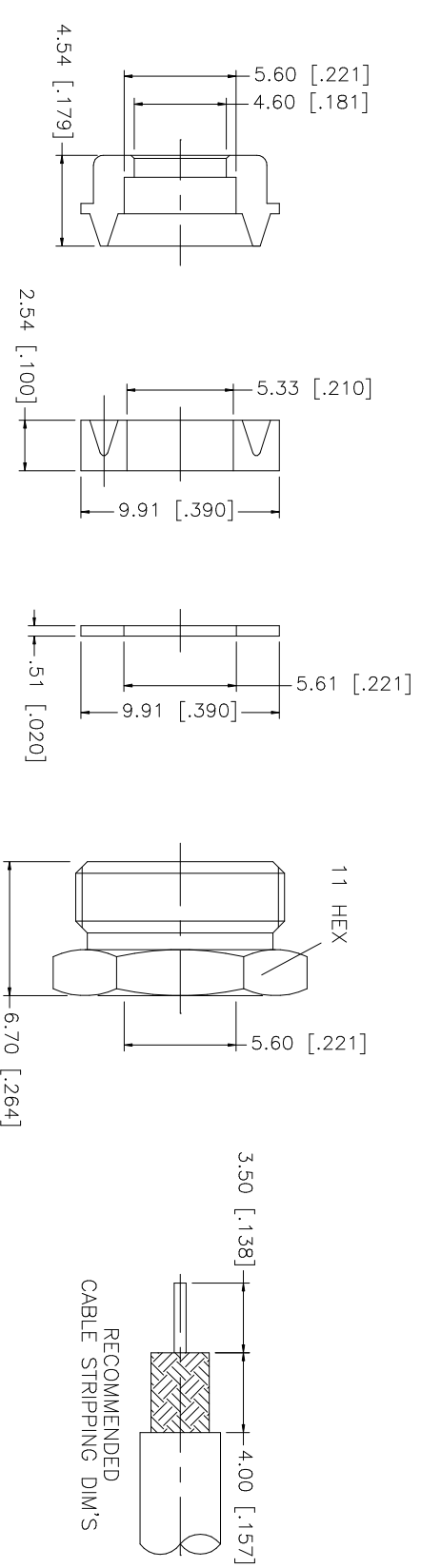
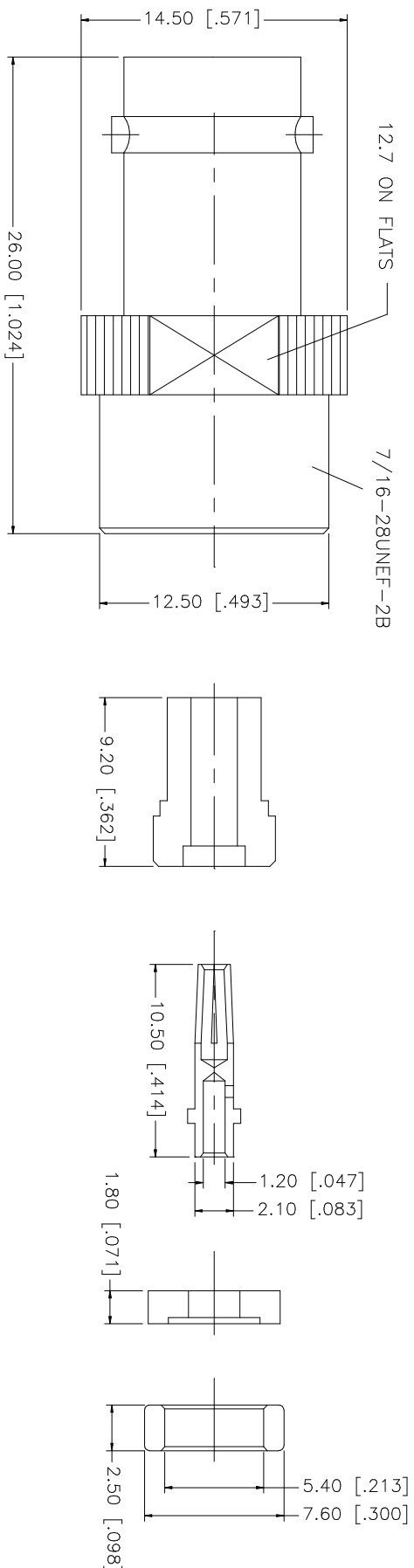

QTY	FINISH	MATERIAL	DESCRIPTION
1	NICKEL	BRASS	HEX NUT
1	NICKEL	BRASS	WASHER
1	RED	SILICONE	GASKET
1	NICKEL	BRASS	BRAID CLAMP
1	NICKEL	BRASS	RING
1	NATURAL	TEFLON	INSULATOR
1	GOLD	PHOS. BRONZE	CONTACT PIN
1	NATURAL	TEFLON	INSULATOR
1	NICKEL	BRASS	BODY

APPROVALS	DATE
DRAWN G.R.S.	07/19/05

DO NOT SCALE DRAWING
UNLESS OTHERWISE SPECIFIED DIMENSIONS ARE IN MILLIMETERS DIMENSIONS IN [] ARE IN INCHES AND FOR CUSTOMER REFERENCE ONLY.
UNLESS OTHERWISE SPECIFIED TOLERANCES FOR MILLIMETERS ARE: 0.5 - 8mm ± 0.20mm 8 - 30mm ± 0.40mm 30 - 120mm ± 0.50mm
UNLESS OTHERWISE SPECIFIED TOLERANCES FOR INCHES ARE: .020 - .315 = ± 0.007" .315 - 1.180 = ± 0.015" 1.180 - 4.724 = ± 0.020"

PART DESCRIPTION
BNC CLAMP JACK (FOR RG-58C/U, 58/U, 142A/U, 223/U)

CAD FILE	DWG. NO.	REV.	NC	SIZE	SCALE
C:/112/112372.DWG	112372.DWG	NC		A	NA

Amphenol Connex

Mouser Electronics

Authorized Distributor

Click to View Pricing, Inventory, Delivery & Lifecycle Information:

[Amphenol:](#)

[112372](#)