

DESCRIPTION: HIGH DENSITY - MACHINED CONTACTS - SOLDER CUP

**MATERIALS AND FINISH:**

SHELL: STEEL MATERIAL, NICKEL FINISH  
 INSULATOR: PBT THERMOPLASTIC 30% GLASS FILLED, UL 94V-0 RATED, BLACK COLOR  
 CONTACT MATERIAL: COPPER ALLOY  
 CONTACT FINISH: GOLD PLATED

**ELECTRICAL:**

CONTACT CURRENT RATING: 3 AMPS  
 CONTACT RESISTANCE: 10 mOHMS Max.  
 DIELECTRIC WITHSTANDING VOLTAGE: 1,000VAC Min.  
 INSULATION RESISTANCE: 5 GOHMS Min.  
 TEMPERATURE RATING: -55° ~ +125° C

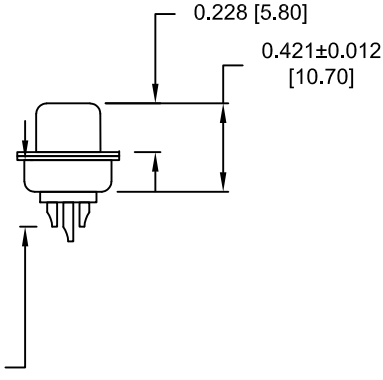
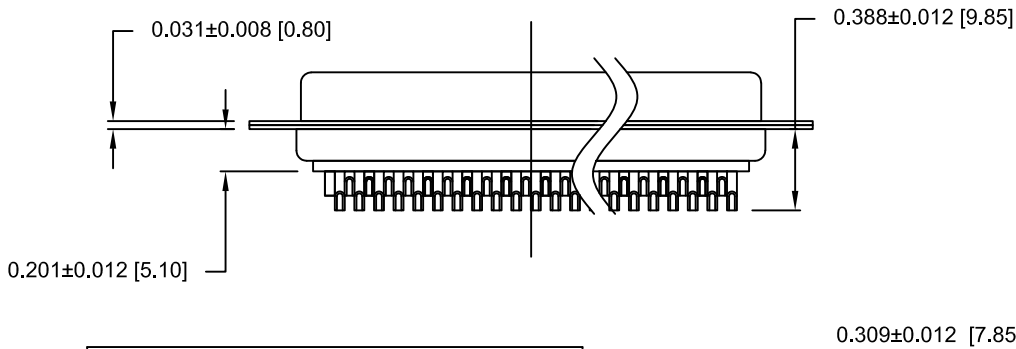
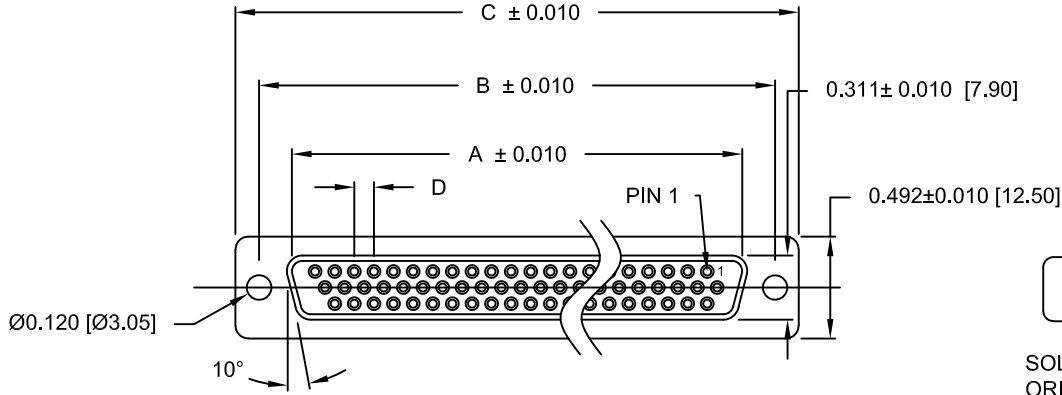

**180-MYY-20YLYYY**

SERIES \_\_\_\_\_  
 MACHINED CONTACTS \_\_\_\_\_  
 POSITION \_\_\_\_\_  
 15 \_\_\_\_\_  
 26 \_\_\_\_\_  
 44 \_\_\_\_\_  
 62 \_\_\_\_\_  
 GENDER \_\_\_\_\_  
 2 = FEMALE \_\_\_\_\_  
 TERMINATION \_\_\_\_\_  
 0 = SOLDER CUP \_\_\_\_\_  
 SHELL PLATING \_\_\_\_\_  
 3 = NICKEL \_\_\_\_\_  
 RoHS (LOW TEMP.) 230° PROCESS \_\_\_\_\_  
 HARDWARE \_\_\_\_\_  
 00 = Ø 0.120" HOLE \_\_\_\_\_  
 01 = 0.098" 4-40 INSERT, BOARD SIDE \_\_\_\_\_  
 02 = 0.236" 4-40 INSERT, BOARD SIDE \_\_\_\_\_  
 03 = 0.236" 4-40 INSERT, MATING SIDE \_\_\_\_\_  
 CONTACT PLATING \_\_\_\_\_  
 1 = GOLD FLASH, ENTIRE CONTACT \_\_\_\_\_  
 2 = 30u" GOLD, ENTIRE CONTACT \_\_\_\_\_

DIMENSIONS (IN.)				
No. OF PINS	A	B	C	D
15	0.642	0.984	1.213	0.090
26	0.969	1.311	1.543	0.090
44	1.512	1.852	2.089	0.090
62	2.157	2.500	2.732	0.095

DIMENSIONS (mm)				
No. OF PINS	A	B	C	D
15	16.30	25.00	30.80	2.29
26	24.60	33.30	39.20	2.29
44	38.40	47.05	53.05	2.29
62	54.80	63.50	69.40	2.41

ACCEPTS 28 - 24 AWG WIRE

UNITS = INCHES [mm]

DO NOT SCALE FROM DRAWING

RoHS COMPLIANT

	THESE DRAWINGS AND SPECIFICATIONS ARE THE PROPERTY OF NorComp AND SHALL NOT BE REPRODUCED, COPIED OR USED AS THE BASIS FOR THE MANUFACTURE OF SALE OF APPARATUS WITHOUT WRITTEN PERMISSION.		DRAWN: C. SMITH	DATE: 03-13-07
	<b>NorComp</b>		SCALE: NTS	SHEET 1 OF 2
DWG NO. 180-MYY-20YLYYY				

DESCRIPTION: CLINCH NUT HARDWARE

TOLERANCE:  
ALL DIMENSIONS ARE  $\pm 0.008$

ALL CLINCH-NUTS ARE 4-40 INTERNAL THREADS

01X ..... 0.098" (BOARD SIDE)

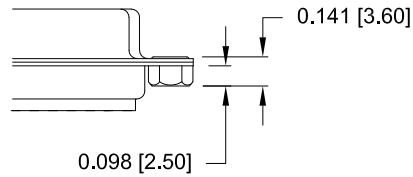

02X ..... 0.236" (BOARD SIDE)

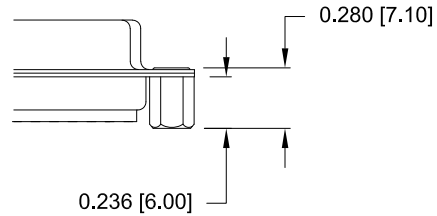

03X..... 0.236" (MATING SIDE)

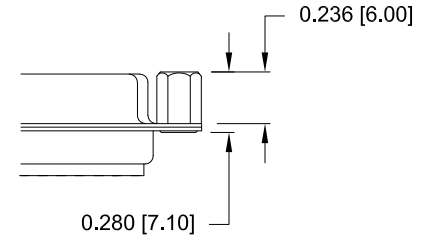

UNITS = INCHES [mm]

DO NOT SCALE FROM DRAWING



THESE DRAWINGS AND SPECIFICATIONS ARE THE PROPERTY OF NorComp AND SHALL NOT BE REPRODUCED, COPIED OR USED AS THE BASIS FOR THE MANUFACTURE OF SALE OF APPARATUS WITHOUT WRITTEN PERMISSION.

DRAWN:  
C. SMITH

DATE:  
02-12-08

**NorComp**

SCALE: NTS SHEET 2 OF 2 REV 17

DWG NO. 180-MYY-20YLYYY

RoHS COMPLIANT

# Mouser Electronics

Authorized Distributor

Click to View Pricing, Inventory, Delivery & Lifecycle Information:

## NorComp:

[180-M44-203L001](#) [180-M62-203L021](#) [180-M15-203L031](#) [180-M15-203L011](#) [180-M15-203L021](#) [180-M44-203L021](#)  
[180-M44-203L031](#) [180-M62-203L031](#) [180-M44-203L011](#) [180-M15-203L001](#) [180-M62-203L001](#) [180-M26-203L031](#)  
[180-M26-203L011](#) [180-M26-203L001](#) [180-M62-203L011](#) [180-M26-203L021](#)