

PROPER USE GUIDELINES

Cumulative Trauma Disorders can result from the prolonged use of manually powered hand tools. Hand tools are intended for occasional use and low volume applications. A wide selection of powered application equipment for extended-use, production operations is available.

1. INTRODUCTION

This instruction sheet covers TE Connectivity Hand Crimping Tools 601075 and 601075-1, which are used to apply SOLISTRAND* and CABLE MAKER* terminals to stranded copper wire. Figure 2 provides a list of applicable wire sizes, terminal or splice CMA range, and the appropriate minimum and maximum wire strip lengths for each wire size and connector type.

NOTE Do NOT use these tools on aircraft applications or on aluminum wire terminations.



Reasons for reissue are provided in Section 9, REVISION SUMMARY.

2. DESCRIPTION

The hand crimping tools feature two rotating crimping dies that are held in place by spring-loaded indexing pins. Each die is positioned using a spring-loaded die locator pin. Wire size designations are embossed on the crimping dies to assure proper setting of the crimping area, and a die order chart is included on the tool for easy reference.

3. CRIMPING PROCEDURE FOR SOLISTRAND TERMINALS AND SPLICES

3.1. Die Setting (Figure 1)

1. Open the tool handles.
2. Check the die order chart on the tool and select the left (L) and right (R) die numbers for the wire size being used.

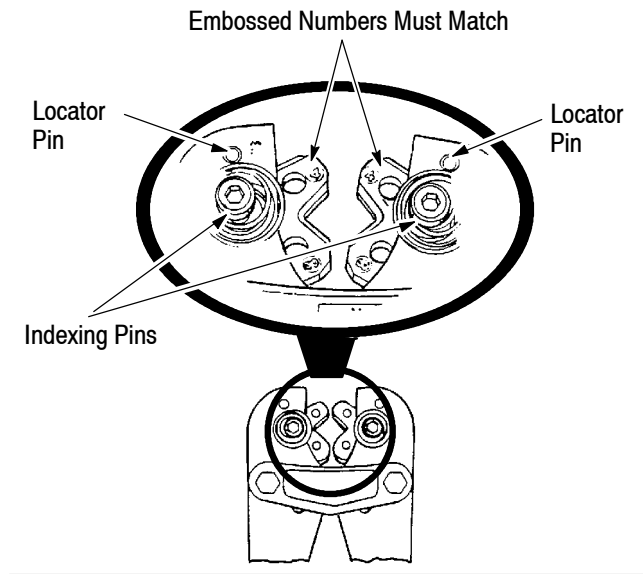

Figure 1

SOLISTRAND TERMINALS AND SPLICES



Ring Type Terminal



Butt Splice



Parallel Splice

TERMINAL OR SPLICE WIRE SIZE RANGE, mm ² [CMA]	APPROX WIRE SIZE, AWG	WIRE STRIP LENGTH					
		TERMINALS		BUTT SPLICES		PARALLEL SPLICES	
		MIN	MAX	MIN	MAX	MIN	MAX
6.6 - 10.5 [13,100 - 20,800]	8	8.33 [.328]	9.12 [.359]	10.32 [.406]	11.11 [.438]	10.32 [.406]	11.11 [.438]
10.5 - 16.7 [20,800 - 33, 100]	6	9.92 [.391]	10.71 [.422]	11.90 [.469]	12.70 [.50]	11.11 [.438]	11.90 [.469]
16.7 - 26.6 [33,100 - 52,600]	4	11.50 [.453]	12.30 [.484]	13.49 [.531]	14.28 [.562]	13.49 [.531]	14.28 [.562]
26.6 - 42.4 [52,600 - 83,700]	2	13.09 [.515]	13.89 [.547]	15.08 [.594]	15.87 [.625]	15.08 [.594]	15.87 [.625]
42.4 - 60.5 [83,700 - 119,500]	1/0	18.65 [.734]	20.24 [.797]	15.87 [.625]	17.46 [.688]	17.46 [.688]	19.05 [.75]

Figure 2

3. Depress the spring-loaded indexing pins and rotate the desired size dies into crimping position. The embossed die numbers must match.

4. When the correct size dies are in position, release the indexing pins. Make sure that the die locator pins return fully and are visible at the points indicated.

NOTE
 Always store the tool with the crimping dies in the No. 4 setting.

3.2. Wire Preparation and Loading (Figure 2)

1. Strip the wire(s) to the dimensions indicated. Do NOT use wires with nicked or missing strands.
2. Select the proper size terminal or splice for the wire size being used.
3. Determine the correct terminal or splice wire loading by referring to the CMA range listed. The total CMA of the wires being used must be within the terminal or splice's CMA range.

3.3. Performing a Single Crimp on Wire Sizes 8 Through 4 (Figure 3)

NOTE
 Make sure that the wire size stamped on the terminal or splice corresponds with the wire size embossed in the tool dies.

1. Center the wire barrel of the terminal or splice in the dies. For best results, position the brazed seam against one of the "flats" of the dies, as shown in Figure 3.
2. Close the tool handles until the terminal or splice is held firmly in place. Do NOT deform the terminal or splice wire barrel.
3. Insert the stripped wire into the terminal or splice until the wire conductor is at least flush with, or is extending beyond, the end of the wire barrel.
4. To complete the crimp, close the tool handles until they bottom. Open the handles and remove the crimped terminal or splice.
5. If terminating a butt splice, repeat the procedure for the second splice end.
6. Refer to Section 5 and Figure 7 for terminal and splice crimp inspection procedure.

3.4. Performing a Dual Crimp on SOLISTRAND Terminals with Wire Size 2 and 1/0 (Figure 4)

NOTE
 For best results, position the brazed seam of the terminal against one of the "flats" of the dies, as shown in Figure 4. Make sure that the crimps do not overlap or go off either end of the wire barrel. Make sure that the wire size being used, the wire size stamped on the terminal, and the wire size embossed on the dies all correspond.

A. First Crimp

1. Position the end of the terminal or splice wire barrel in the dies as shown in Figure 4.
2. Close the tool handles until the terminal or splice is held in place. Do not deform the wire barrel.
3. Insert the stripped wire into the terminal or splice's wire barrel until the end of the conductor is flush with, or is extended slightly beyond, the wire barrel.
4. Complete the crimp by closing the tool handles until they bottom.

B. Second Crimp

1. Move the terminal or splice into position for the second crimp, then close the tool handles to complete the crimp. Do not overlap the crimps.
2. Refer to Section 5 and to Figure 7 for terminal and splice crimp inspection procedures.

3.5. Performing a Dual Crimp on SOLISTRAND Butt Splices with Wire Size 2 and 1/0 (Figure 4)

NOTE
 For best results, position the brazed seam of the terminal against one of the "flats" of the dies, as shown in Figure 4. Make sure that the crimps do not overlap or go off either end of the wire barrel. Make sure that the wire size being used, the wire size stamped on the terminal, and the wire size embossed on the dies all correspond.

A. First and Second Crimps

1. Position the end of the splice wire barrel in the dies.
2. Close the tool handles until the splice is held in place. Do not deform the wire barrel.
3. Insert a properly stripped wire into the first end of the splice until the wire bottoms against the splice wire stop.
4. Close the tool handles until they bottom to complete the crimp.
5. Move the splice into position for the second crimp, as shown in Figure 4.
6. Close the tool handles to complete the crimp. Do not overlap the crimps.

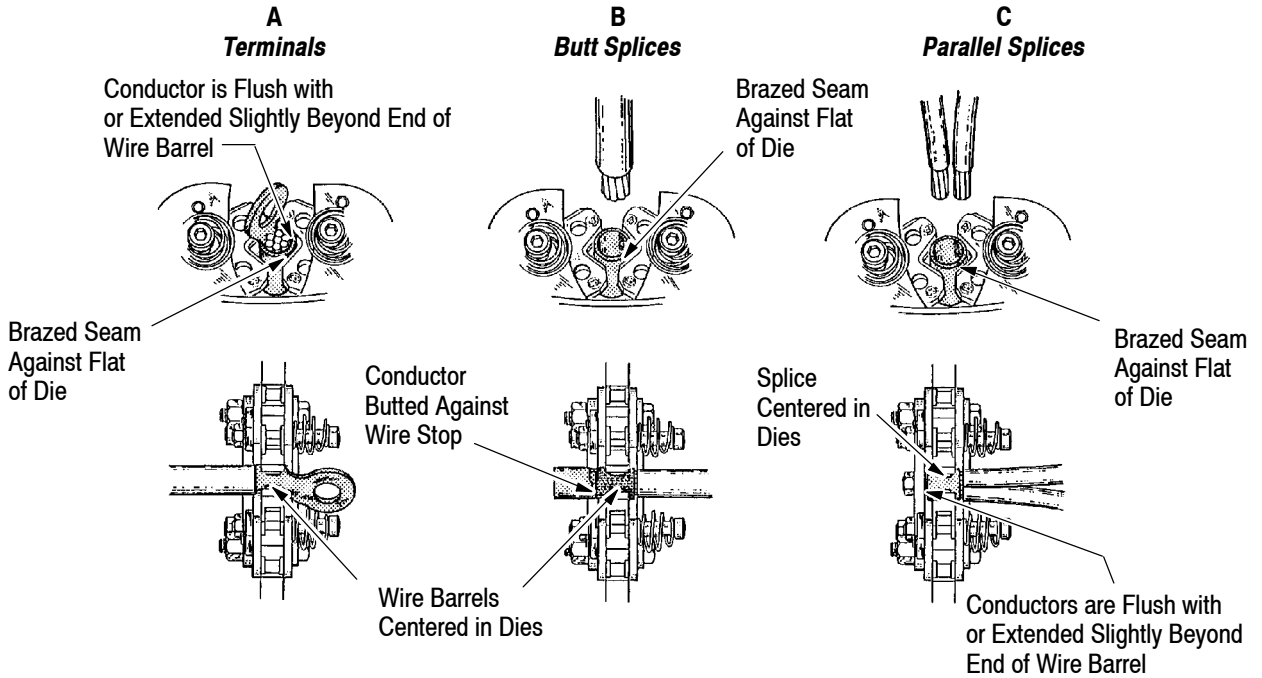

Figure 3

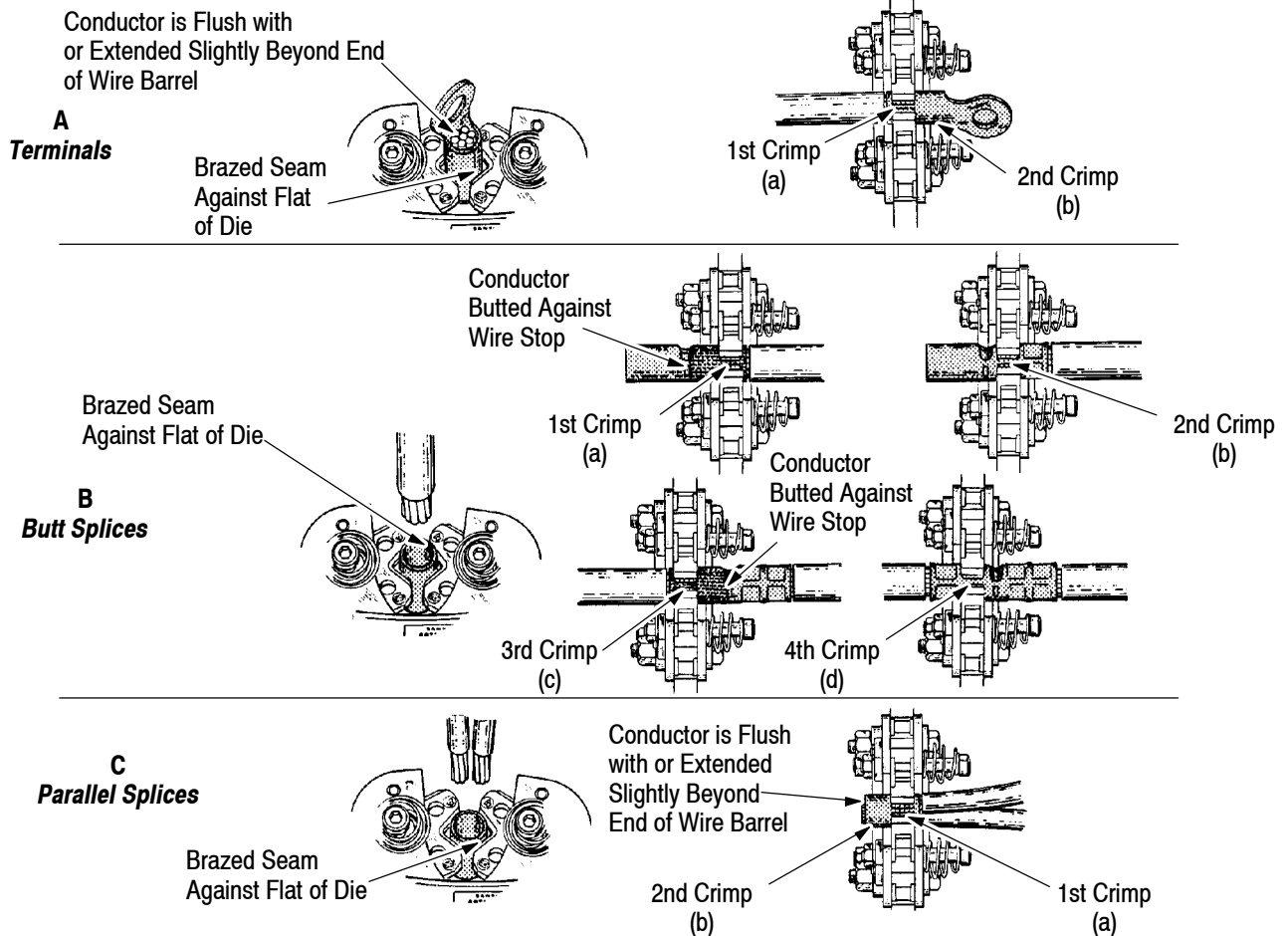

Figure 4

B. Third and Fourth Crimps (Figure 4)

1. Position the splice into position for the third crimp.
2. Close the tool handles until the splice is held in place. Do not deform the wire barrel.
3. Insert a properly stripped wire into the second end of the splice until the wire bottoms against the splice wire stop.
4. Close the tool handles until they bottom to complete the crimp.
5. Move the splice into position for the fourth crimp.
6. Close the tool handles to complete the crimp. Do not overlap the crimps.
7. Refer to Section 5 and Figure 7 for terminal and splice crimp inspection procedure.

3.6. Performing a Dual Crimp on SOLISTRAND Parallel Splices with Wire Size 2 and 1/0 (Figure 4)



For best results, position the brazed seam of the terminal against one of the “flats” of the dies, as shown in Figure 4. Make sure that the crimps do not overlap or go off either end of the wire barrel. Make sure that the wire size being used, the wire size stamped on the terminal, and the wire size embossed on the dies all correspond.

A. First Crimp

1. Position the end of the splice wire barrel in the dies.
2. Close the tool handles until the splice is held in place. Do not deform the wire barrel.
3. Insert the properly stripped wire into the wire barrel until the ends of the conductors are flush with or extended slightly beyond the end of the wire barrel.
4. Close the tool handles until they bottom to complete the crimp.

B. Second Crimp

1. Move the splice into position for the second crimp and close the tool handles to complete the crimp. Do not overlap the crimps.
2. Refer to Section 5 and Figure 7 for terminal and splice crimp inspection procedure.

4. CRIMPING PROCEDURE FOR CABLE MAKER BATTERY TERMINALS

4.1. Die Setting

Proper die setting is determined by the part number of the terminal being crimped and by the number displayed in “area 2” of the terminal, as shown in Figure 5.

1. Open the tool handles.
2. Depress the spring-loaded index pins.
3. Rotate the dies until the embossed wire size numbers in each die crimp closure match the number displayed in “area 2” of the terminal.
4. Release the indexing pins, making sure that the die locator pins return fully and are visible at the points indicated in Figure 1.

4.2. Wire Preparation and Loading

1. Strip the wires to the dimensions indicated in Figure 5.

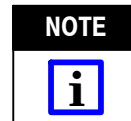

Do not use wires with nicked or missing strands.

2. Select the proper terminal number for the wire diameter being used. The diameter of the stripped wire must fall within the wire diameter range of the terminal being used. Refer to Figure 5.

4.3. Crimping Procedure for Straight Terminals (Figure 6)

A. First Crimp

1. Position the end of the terminal wire barrel in the dies.
2. Close the tool handles until the terminal is held in place. Do not deform the wire barrel.
3. Insert the properly stripped wire into the wire barrel until the wire bottoms.
4. Close the tool handles until the dies bottom to complete the crimp.

B. Second Crimp

1. Move the terminal into position for the second crimp, then close the handles to complete the crimp.
2. Refer to Section 5 and Figure 8 for terminal crimp inspection procedure.

CABLE MAKER Battery Terminals

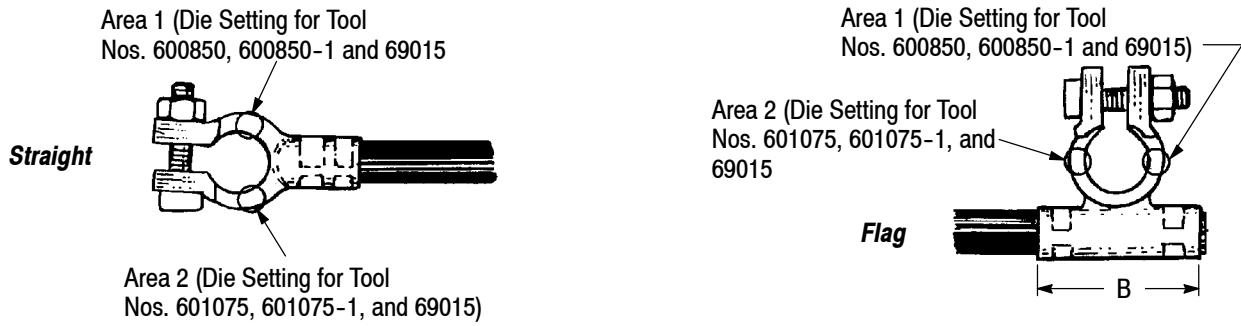

TERMINAL PART NUMBER	WIRE DIAMETER RANGE	TOOL DIE SETTINGS (See Area 2 on Terminal)	WIRE STRIP LENGTH		
			STRAIGHT		FLAG
			MIN	MAX	
29251	5.56 - 6.91 [.219 - .272]	4	20.637 [.813]	21.432 [.843]	"B" Dim +.795 [.031]
29253	4.75 - 5.54 [.187 - .218]	6			
29245-3	9.78 - 10.97 [.385 - .432]	0			
29245-5					
29249	6.93 - 8.76 [.273 - .345]	2			
29249-3					
29249-5					

Figure 5

4.4. Crimping Procedure for Flag Terminals (Figure 6)

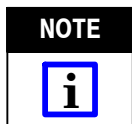

Make sure that crimps do not overlap or go off the end of the wire barrel.

A. First Crimp (Figure 6)

1. Orient and position the flag terminal in the tool dies.
2. Close the tool handles until the terminal is held in place. Do not deform the wire barrel.
3. Insert the properly stripped wire until the end of the conductor is flush with, or extends approximately .79 [.031] in. beyond, the end of the terminal wire barrel.
4. Close the tool handles to complete the crimp.

B. Second Crimp (Figure 6)

1. Move the terminal into position for the second crimp. Close the tool handles to complete the crimp.
2. Refer to Section 5 and Figure 8 for battery terminal crimp inspection procedure.

5. CRIMP INSPECTION

Inspect the crimped SOLISTRAND terminal or splice by checking the features described in Figure 7. Inspect the crimped CABLE MAKER terminal by checking the features described in Figure 8. Use only terminals and splices that meet the conditions described.

6. INITIAL TOOL INSPECTION

AMP Hand Crimping Tools 601075 and 601075-1 are inspected before shipment. The tool received should be inspected immediately upon arrival to ensure that it has not been damaged during shipment, and that it performs according to the criteria described in this sheet. If the tool is damaged upon arrival, retain the shipping container, file a claim with the carrier, and notify TE immediately.

7. MAINTENANCE/INSPECTION

7.1. Daily Maintenance

1. Remove dust, moisture, and other contaminants from the tool with a clean brush or a soft, lint-free cloth. Do NOT use objects that could damage the tool.

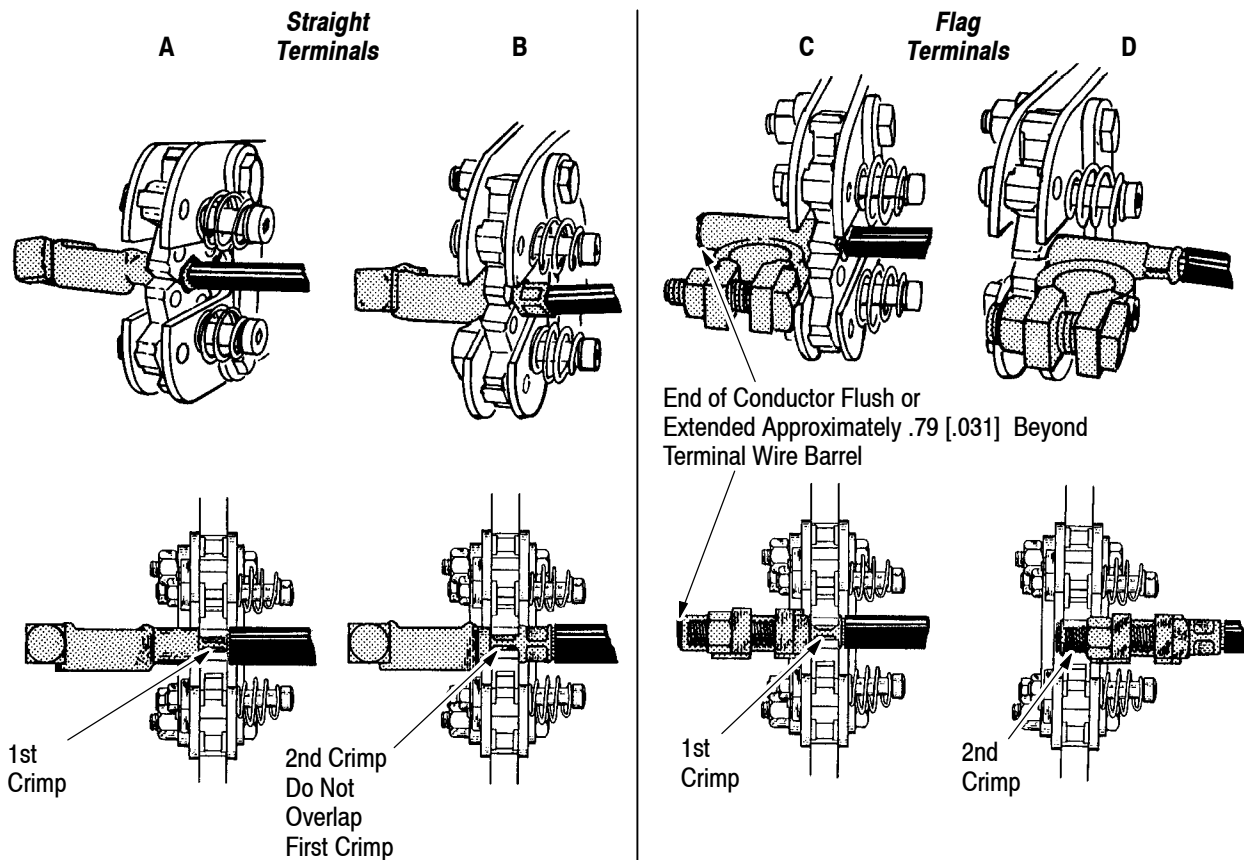

Figure 6

2. Make certain that all pins, pivot points, and bearing surfaces are protected with a THIN coat of any good SAE 20 motor oil. Do NOT oil excessively.

3. When the tool is not in use, keep the handles closed to prevent objects from becoming lodged in the crimping areas and store the tool in a clean, dry area.

7.2. Periodic Inspection

Regular inspections should be performed by quality control personnel. A record of scheduled inspections should remain with the tool and/or be supplied to supervisory personnel responsible for the tool. Though recommendations call for at least one inspection per month, the inspection frequency should be based on the amount of use, working conditions, operator training and skill, and established company standards. These inspections should be performed in the following sequence:

A. Visual Inspection

1. Remove all lubrication and accumulated film by immersing the tool (handles partially closed) in a suitable commercial degreaser that will not affect paint or plastic material.

2. Make certain that all parts are securely in place. If replacements are necessary, refer to the parts list in Figure 11.

3. Inspect crimping areas for chipped or cracked surfaces.

B. Handle Adjustment Inspection (Figure 9)

The handle adjustment should be checked to ensure that the dies are bottoming fully. The handle adjustment feature is provided to compensate for normal die wear. To check the handle adjustment:

1. Open the tool handles fully.
2. Rotate the No. 4 wire size dies into crimping position.
3. Close the tool handles until the dies are bottomed, but not under pressure.
4. Measure the distance between the tool handles, as shown in Figure 9. The measurement must be between 28.58 [1.125] and 38.10 [1.500]. If the adjustment does not fall within this range, the adjustment must be tightened or loosened as necessary.

**Single Crimp
SOLISTRAND Terminals
and Splices**

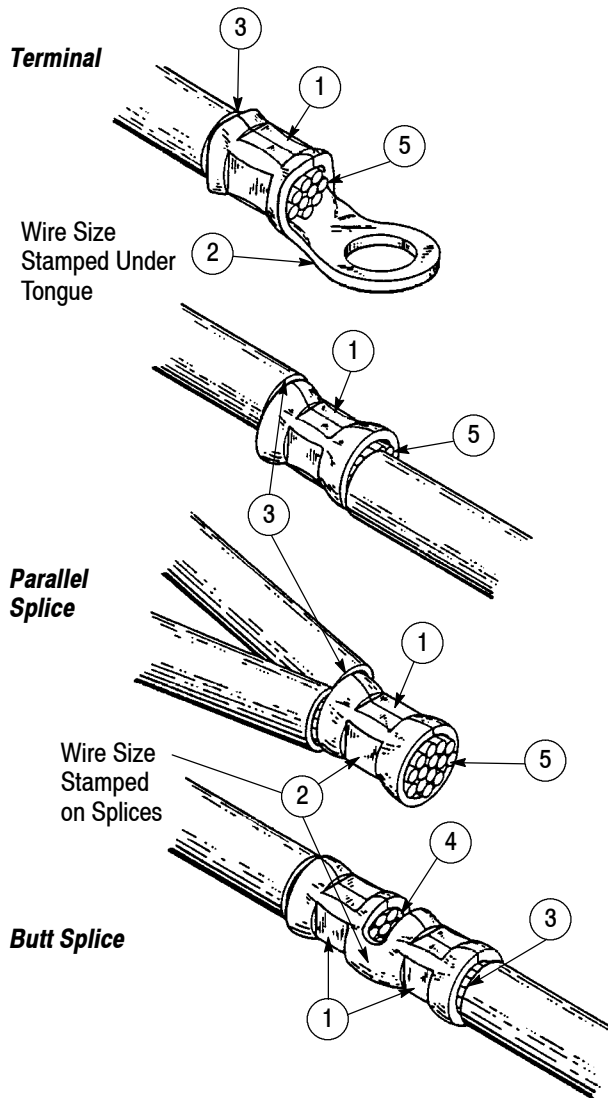

- ① Crimp centered. Crimp may be off center BUT NOT OFF END OF WIRE BARREL.
- ② Wire size stamped on terminal or splice matches CMA of wire being used.
- ③ Insulation does not enter wire barrel.
- ④ Wire is visible through inspection hole of butt splice.
- ⑤ On terminals and parallel splices, bare wire ends must be flush with or extend slightly beyond end of wire barrel.

**Dual Crimp
SOLISTRAND Terminals
and Splices**

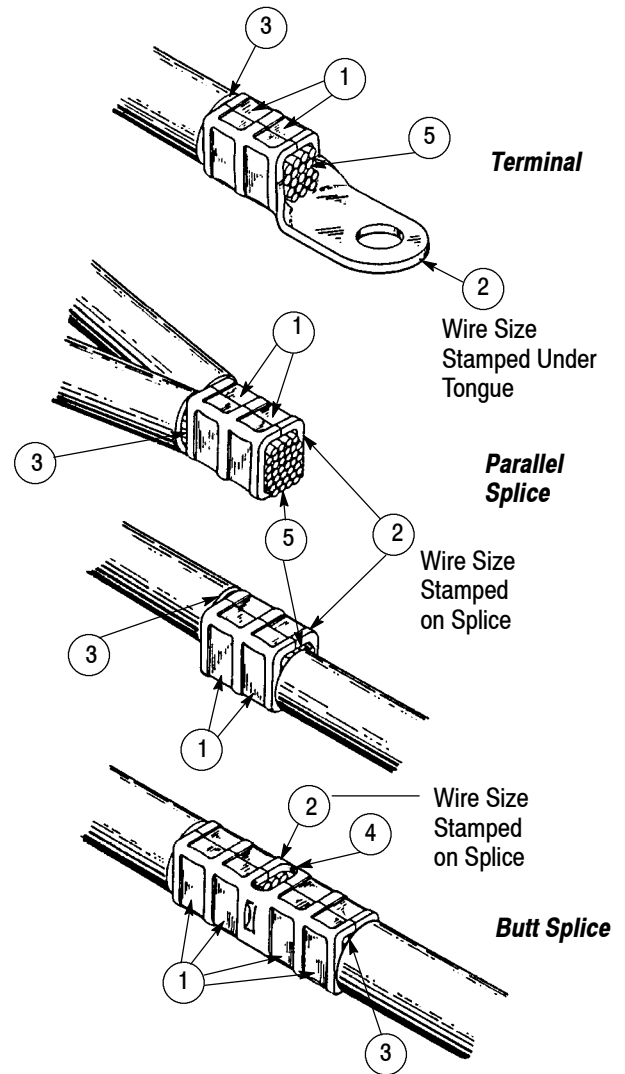

- ① Crimps evenly spaced BUT NOT OVERLAPPED OR OFF END OF WIRE BARREL.
- ② Wire size stamped on terminal or splice matches CMA of wire being used.
- ③ Insulation does not enter wire barrel.
- ④ Wire is visible through inspection hole of butt splice.
- ⑤ On terminals and parallel splices, bare wire ends must be flush with or extend slightly beyond end of wire barrel.

Figure 7

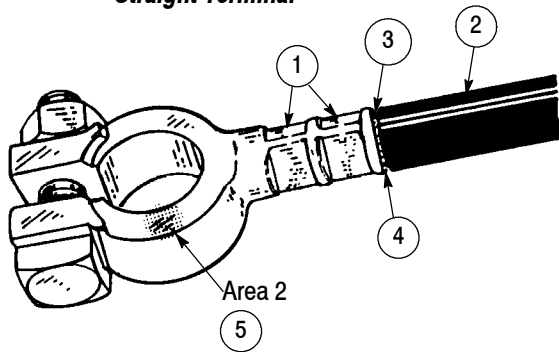
CABLE MAKER Battery Terminals
Straight Terminal

Straight Terminal

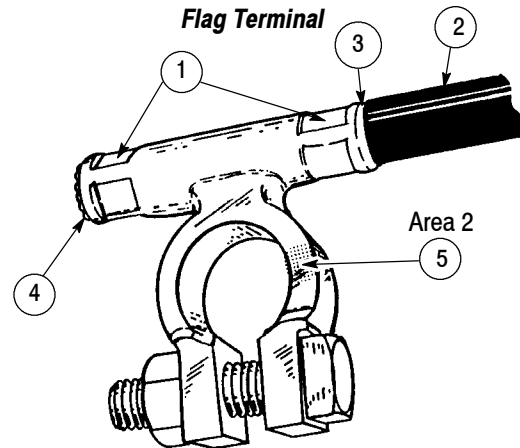
- ① Crimps evenly spaced BUT NOT OVERLAPPED OR OFF END OF WIRE BARREL.
- ② Diameter of stripped wire is within wire diameter range of terminal.
- ③ No nicked or missing conductor strands.
- ④ Wire fully inserted.
- ⑤ Selected die numbers match the number displayed in Area 2.

Flag Terminal

Flag Terminal

- ① Crimps properly located. Crimps must not be off end of wire barrel.
- ② Diameter of stripped wire is within wire diameter range of terminal.
- ③ No nicked or missing conductor strands.
- ④ End of conductor is flush or extended approximately 0.79 [.031] beyond end of terminal wire barrel.
- ⑤ Selected die numbers match the number displayed in Area 2.

Figure 8

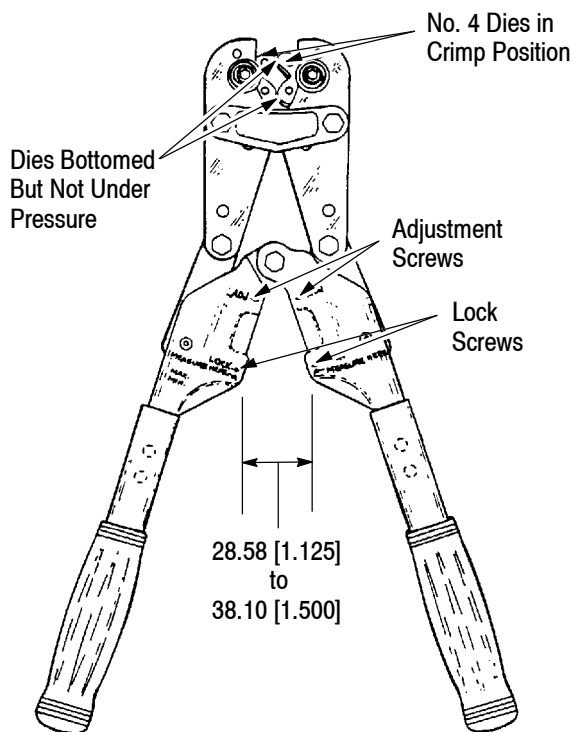

Figure 9

5. To loosen the adjustment:
 - a. -Turn both adjustment (ADJ) screws COUNTERCLOCKWISE approximately 1/8 to 1/4 turn.
 - b. -Slightly loosen both lock (LOCK) screws by turning them COUNTERCLOCKWISE.
 - c. -Flex the tool by opening and closing the tool handles.
 - d. -Tighten both lock screws.
 - e. -Close the tool handles until the dies are bottomed, but not under pressure. Check the measurement between the tool handles and repeat the adjustment procedure if necessary.
6. To tighten the adjustment:
 - a. -Turn both lock (LOCK) screws COUNTERCLOCKWISE approximately 1/2 to 3/4 turn. -Turn both adjustment (ADJ) screws CLOCKWISE approximately 1/8 to 1/4 turn.
 - b. -Flex the tool by opening and closing the tool handles.
 - c. -Tighten both lock (LOCK) screws.
 - d. -Close the tool handles until the dies are bottomed but not under pressure. Check the measurement between the tool handles and repeat the adjustment procedure if necessary.

C. Crimp Height Inspection (Figure 10)

Crimp height inspections should be performed periodically to determine if the tool is maintaining proper crimping dimensions. To check the crimp height:

1. Perform the handle adjustment inspection as described in Paragraph B, Handle Adjustment Inspection. Adjust the handles if necessary.
2. Crimp a properly prepared stranded wire in a SOLISTRAND terminal or splice, as previously described.

NOTE Do not use wires with missing conductor strands.



3. Using a conventional cone-point micrometer, measure the crimp heights at the midpoints of flats "A" and "B", as shown in Figure 10. The SUM of the two measurements equals the crimp height dimension.

NOTE Do not allow the cone point to enter the terminal brazed seam.



4. Figure 10 lists the crimp height dimension (sum of "A" and "B" measurements) range for each wire size. If the measured dimension is within the listed range, the die closure is considered dimensionally correct.
5. If the measured crimp height dimension is not within the specified range (and the tool handles are properly adjusted), crimping tool should be returned to TE for reconditioning. Refer to Section 8, REPAIR/REPLACEMENT.

8. REPAIR/REPLACEMENT

Replaceable parts are listed in Figure 11. Parts other than those listed in Figure 11 should be replaced by TE to ensure quality and reliability of the tool. Order replacement parts through your TE representative, or call 1-800-526-5142, or send a facsimile of your purchase order to 1-717-986-7605, or write to:

CUSTOMER SERVICE (38-35)
 TYCO ELECTRONICS CORPORATION
 P.O. BOX 3608
 HARRISBURG, PA 17105-3608

For tool repair service, please contact a TE Representative at 1-800-526-5136.

9. REVISION SUMMARY

- Updated document to incorporate requirements
- New logo

Crimp Height Measurements (Tool Handles Properly Adjusted. See paragraph 7.2, B)

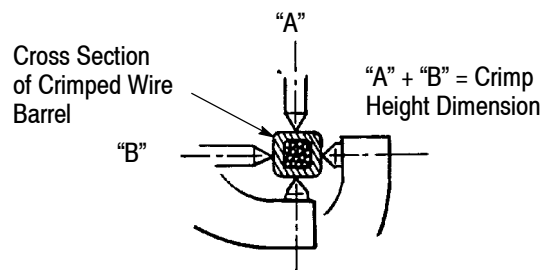
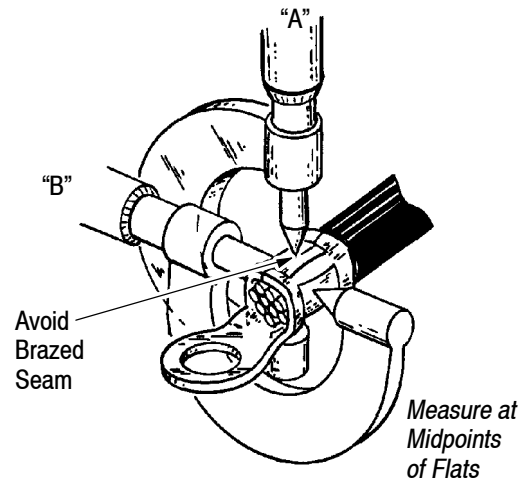

WIRE SIZE, AWG	CRIMP HEIGHT MEASUREMENT ■	CRIMP HEIGHT DIMENSION RANGE
8	MEASUREMENTS "A" + "B" = CRIMP HEIGHT DIMENSION	10.46-11.05 [.412-.435]
6		13.00-13.59 [.512-.535]
4		16.23-16.92 [.639-.666]
2		19.41-20.14 [.764-.793]
1/0		22.63-23.42 [.891-.922]

■ Tool handles properly adjusted.

Figure 10

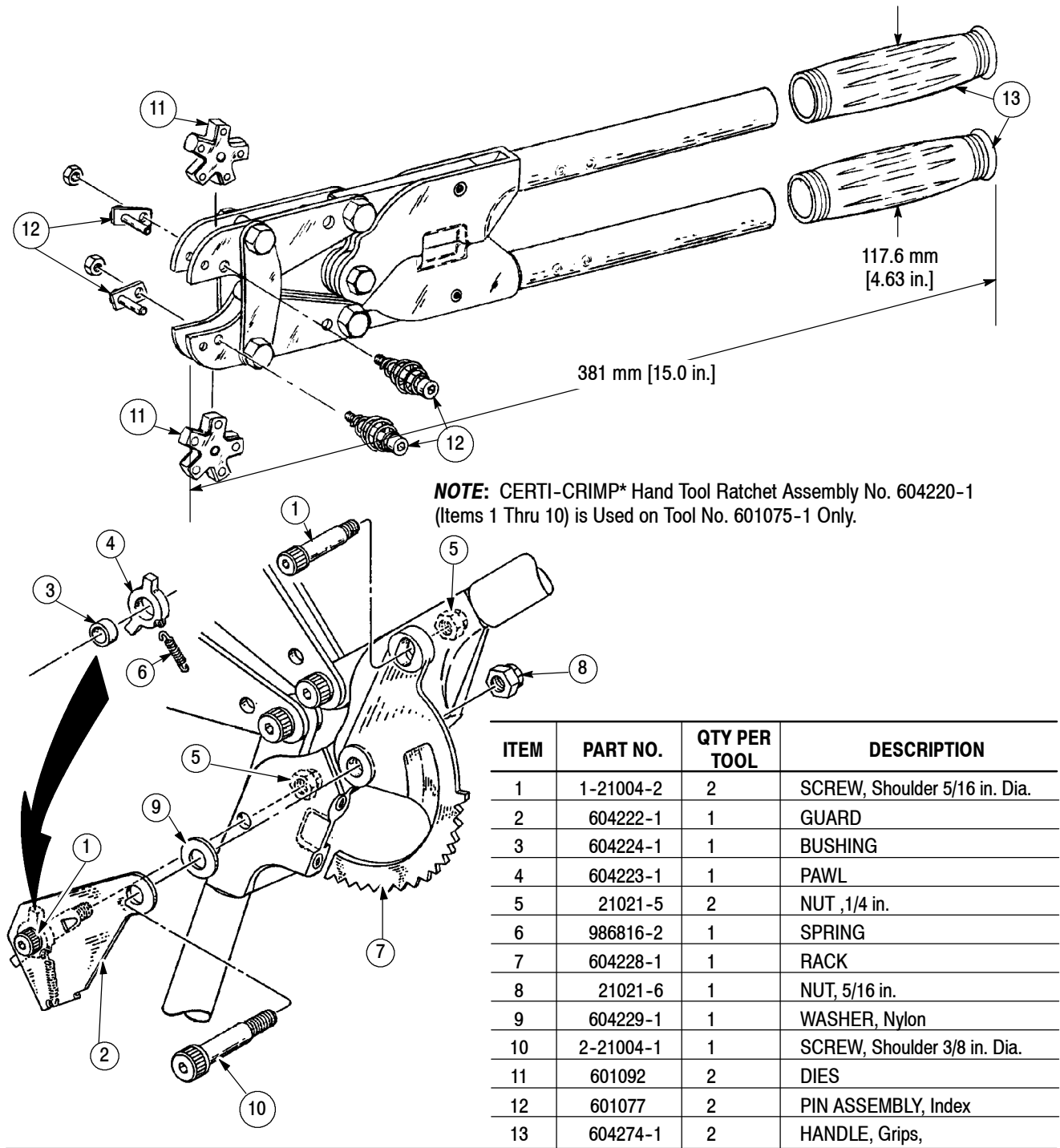

Figure 11

Mouser Electronics

Authorized Distributor

Click to View Pricing, Inventory, Delivery & Lifecycle Information:

[TE Connectivity:](#)

[601075](#) [601075-1](#)