

# EiceDRIVER™

High voltage gate driver IC

## 6ED family - 2nd generation

3 phase 600 V gate drive IC

6ED003L06-F2

6ED003L02-F2

EiceDRIVER™

datasheet

<Revision 2.8>, 05.08.2016

Industrial Power Control

**Edition 05.08.2016**

**Published by  
Infineon Technologies AG  
81726 Munich, Germany**

**© 2016 Infineon Technologies AG  
All Rights Reserved.**

#### **IMPORTANT NOTICE**

The information given in this document shall in no event be regarded as a guarantee of conditions or characteristics ("Beschaffenheitsgarantie").

With respect to any examples, hints or any typical values stated herein and/or any information regarding the application of the product, Infineon Technologies hereby disclaims any and all warranties and liabilities of any kind, including without limitation warranties of non-infringement of intellectual property rights of any third party.

In addition, any information given in this document is subject to customer's compliance with its obligations stated in this document and any applicable legal requirements, norms and standards concerning customer's products and any use of the product of Infineon Technologies in customer's applications.

The data contained in this document is exclusively intended for technically trained staff. It is the responsibility of customer's technical departments to evaluate the suitability of the product for the intended application and the completeness of the product information given in this document with respect to such application.

Please note that this product is not qualified according to the AEC Q100 or AEC Q101 documents of the Automotive Electronics Council.

#### **WARNINGS**

Due to technical requirements products may contain dangerous substances. For information on the types in question please contact your nearest Infineon Technologies office.

Except as otherwise explicitly approved by Infineon Technologies in a written document signed by authorized representatives of Infineon Technologies, Infineon Technologies' products may not be used in any applications where a failure of the product or any consequences of the use thereof can reasonably be expected to result in personal injury.

## Revision History

Page or Item	Subjects (major changes since previous revision)
<b>&lt;Revision 2.8&gt;, 05.08.2016</b>	
p.15	Increased the maximum operating ambient temperature to 105 °C
p.2	Updated disclaimer
p.11	Updated parameter $V_{HO}$
all	revised wording for test temperature
pp. 8	Delete link to application note

## Trademarks of Infineon Technologies AG

AURIX™, BlueMoon™, C166™, CanPAK™, CIPOS™, CIPURSE™, COMNEON™, EconoPACK™, CoolMOS™, CoolSET™, CORECONTROL™, CROSSAVE™, DAVE™, EasyPIM™, EconoBRIDGE™, EconoDUAL™, EconoPIM™, EiceDRIVER™, eupec™, FCOS™, HITFET™, HybridPACK™, I<sup>2</sup>RF™, ISOFACE™, IsoPACK™, MIPAQ™, ModSTACK™, my-d™, NovalithIC™, OmniTune™, OptiMOS™, ORIGA™, PRIMARION™, PrimePACK™, PrimeSTACK™, PRO-SIL™, PROFET™, RASIC™, ReverSave™, SatRIC™, SIEGET™, SINDRION™, SIPMOS™, SMARTi™, SmartLEWIS™, SOLID FLASH™, TEMPFET™, thinQ!™, TRENCHSTOP™, TriCore™, X-GOLD™, X-PMU™, XMM™, XPOSYS™.

## Other Trademarks

Advance Design System™ (ADS) of Agilent Technologies, AMBA™, ARM™, MULTI-ICE™, KEIL™, PRIMECELL™, REALVIEW™, THUMB™,  $\mu$ Vision™ of ARM Limited, UK. AUTOSAR™ is licensed by AUTOSAR development partnership. Bluetooth™ of Bluetooth SIG Inc. CAT-iq™ of DECT Forum. COLOSSUS™, FirstGPS™ of Trimble Navigation Ltd. EMV™ of EMVCo, LLC (Visa Holdings Inc.). EPCOS™ of Epcos AG. FLEXGO™ of Microsoft Corporation. FlexRay™ is licensed by FlexRay Consortium. HYPERTERMINAL™ of Hilgraeve Incorporated. IEC™ of Commission Electrotechnique Internationale. IrDA™ of Infrared Data Association Corporation. ISO™ of INTERNATIONAL ORGANIZATION FOR STANDARDIZATION. MATLAB™ of MathWorks, Inc. MAXIM™ of Maxim Integrated Products, Inc. MICROTEC™, NUCLEUS™ of Mentor Graphics Corporation. Mifare™ of NXP. MIPI™ of MIPI Alliance, Inc. MIPS™ of MIPS Technologies, Inc., USA. muRata™ of MURATA MANUFACTURING CO., MICROWAVE OFFICE™ (MWO) of Applied Wave Research Inc., OmniVision™ of OmniVision Technologies, Inc. Openwave™ Openwave Systems Inc. RED HAT™ Red Hat, Inc. RFMD™ RF Micro Devices, Inc. SIRIUS™ of Sirius Satellite Radio Inc. SOLARIS™ of Sun Microsystems, Inc. SPANSION™ of Spansion LLC Ltd. Symbian™ of Symbian Software Limited. TAIYO YUDEN™ of Taiyo Yuden Co. TEAKLITE™ of CEVA, Inc. TEKTRONIX™ of Tektronix Inc. TOKO™ of TOKO KABUSHIKI KAISHA TA. UNIX™ of X/Open Company Limited. VERILOG™, PALLADIUM™ of Cadence Design Systems, Inc. VLYNQ™ of Texas Instruments Incorporated. VXWORKS™, WIND RIVER™ of WIND RIVER SYSTEMS, INC. ZETEX™ of Diodes Zetex Limited.

Last Trademarks Update 2010-10-26

## Table of Contents

<b>1</b>	<b>Overview .....</b>	<b>5</b>
<b>2</b>	<b>Blockdiagram.....</b>	<b>6</b>
<b>3</b>	<b>Pin configuration, description, and functionality .....</b>	<b>7</b>
3.1	Low Side and High Side Control Pins (Pin 2, 3, 4, 5, 6, 7) .....	7
3.2	EN (Gate Driver Enable, Pin 10) .....	8
3.3	/FAULT (Fault Feedback, Pin 8) .....	8
3.4	ITRIP and RCIN (Over-Current Detection Function, Pin 9, 11) .....	9
3.5	VCC, VSS and COM (Low Side Supply, Pin 1, 12,13) .....	9
3.6	VB1,2,3 and VS1,2,3 (High Side Supplies, Pin 18, 20, 22, 24, 26, 28) .....	9
3.7	LO1,2,3 and HO1,2,3 (Low and High Side Outputs, Pin 14, 15, 16, 19, 23, 27) .....	9
<b>4</b>	<b>Electrical Parameters.....</b>	<b>10</b>
4.1	Absolute Maximum Ratings .....	10
4.2	Required operation conditions .....	11
4.3	Operating Range .....	11
4.4	Static logic function table .....	12
4.5	Static parameters .....	12
4.6	Dynamic parameters .....	14
<b>5</b>	<b>Timing diagrams.....</b>	<b>15</b>
<b>6</b>	<b>Package.....</b>	<b>18</b>
6.1	PG-DSO-28 .....	18
6.2	PG-TSSOP-28.....	19

## List of Figures

Figure 1	Typical Application .....	6
Figure 2	Block diagram for 6ED003L06-F2 / 6ED003L02-F2 .....	6
Figure 3	Pin Configuration of 6ED003L06-F2 and 6ED003L02-F2 .....	7
Figure 4	Input pin structure.....	7
Figure 5	Input filter timing diagram .....	8
Figure 6	EN pin structures.....	8
Figure 7	/FAULT pin structures .....	8
Figure 8	Timing of short pulse suppression .....	15
Figure 9	Timing of internal deadtime .....	15
Figure 10	Enable delay time definition .....	15
Figure 11	Input to output propagation delay times and switching times definition .....	16
Figure 12	Operating areas.....	16
Figure 13	ITRIP-Timing .....	16
Figure 14	ITRIP input filter time.....	17
Figure 15	Package drawing.....	18
Figure 16	PCB reference layout .....	18
Figure 17	Package drawing.....	19
Figure 18	PCB reference layout (according to JEDEC 1s0P) left: Reference layout right: detail of footprint	19

## List of Tables

Table 1	Members of 6ED family – 2 <sup>nd</sup> generation .....	5
Table 2	Pin Description .....	7
Table 3	Abs. maximum ratings.....	10
Table 4	Required Operation Conditions.....	11
Table 5	Operating range .....	11
Table 6	Static parameters .....	12
Table 7	Dynamic parameters .....	14
Table 8	Data of reference layout.....	19

## EiceDRIVER™ 3 phase 600 V gate drive IC

### 1 Overview

#### Main features

- Thin-film-SOI-technology
- Maximum blocking voltage +600V
- Separate control circuits for all six drivers
- CMOS and LSTTL compatible input (negative logic)
- Signal interlocking of every phase to prevent cross-conduction
- Detection of over current and under voltage supply
- externally programmable delay for fault clear after over current detection

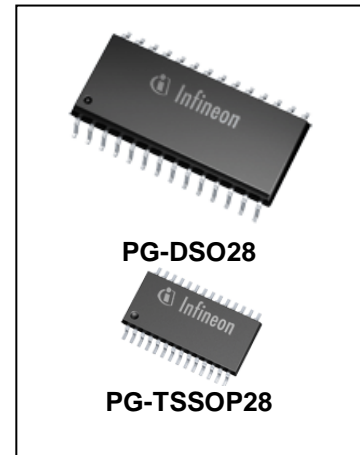

#### Product highlights

- Insensitivity of the bridge output to negative transient voltages up to -50V given by SOI-technology
- 'shut down' of all switches during error conditions

#### Typical applications

- Home appliances
- Fans, pumps
- General purpose drives

#### Product family

**Table 1** Members of 6ED family – 2<sup>nd</sup> generation

Sales Name	high side control input HIN1,2,3 and LIN1,2,3	typ. UVLO- Thresholds	Bootstrap diode	Package
6ED003L06-F2 / 6ED003L02-F2	negative logic	11.7 V / 9.8 V	No	DSO28 / TSSOP28

#### Description

The devices are full bridge drivers to control power devices like MOS-transistors or IGBTs in 3-phase systems with a maximum blocking voltage of +600 V. Based on the used SOI-technology there is an excellent ruggedness on transient voltages. No parasitic thyristor structures are present in the device. Hence, no parasitic latch-up may occur at all temperatures and voltage conditions.

The six independent drivers are controlled at the low-side using CMOS resp. LSTTL compatible signals, down to 3.3 V logic. The device includes an under-voltage detection unit with hysteresis characteristic and an over-current detection. The over-current level is adjusted by choosing the resistor value and the threshold level at pin ITRIP. Both error conditions (under-voltage and over-current) lead to a definite shut down of all six switches. An error signal is provided at the FAULT open drain output pin. The blocking time after over-current can be adjusted with an RC-network at pin RCIN. The input RCIN owns an internal current source of 2.8  $\mu$ A. Therefore, the resistor  $R_{RCIN}$  is optional. The typical output current can be given with 165 mA for pull-up and 375 mA for pull down. Because of system safety reasons a 310 ns interlocking time has been realised. The function of input EN can optionally be extended with an over-temperature detection, using an external NTC-resistor (see Fig.1).

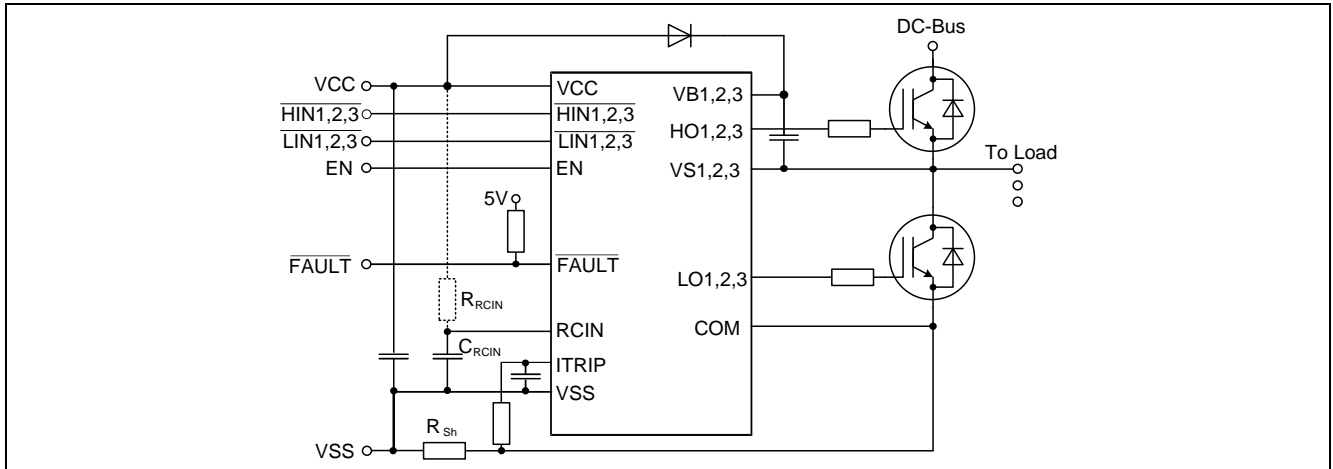

Figure 1 Typical Application

## 2 Blockdiagram

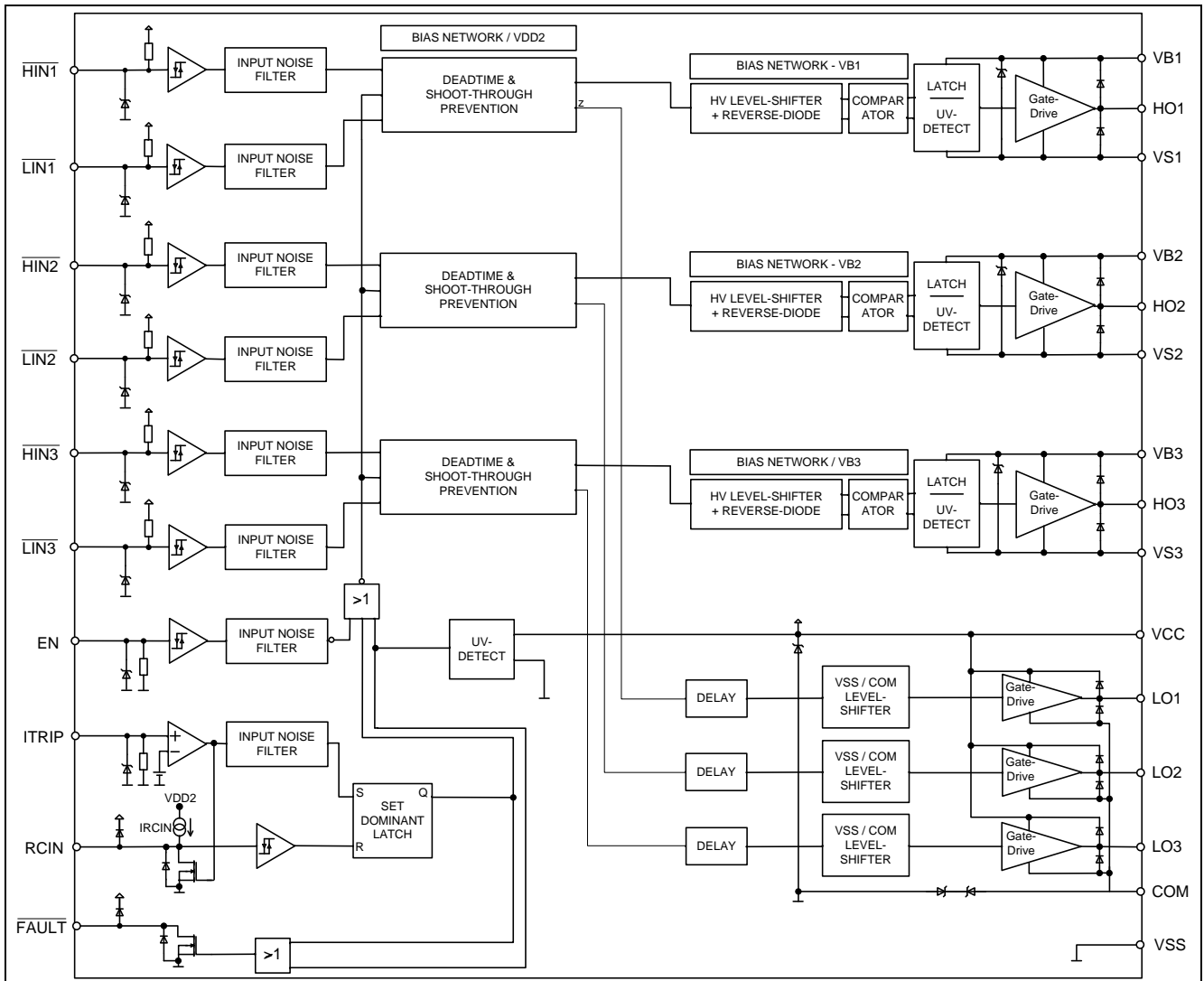

Figure 2 Block diagram for 6ED003L06-F2 / 6ED003L02-F2

### 3 Pin configuration, description, and functionality

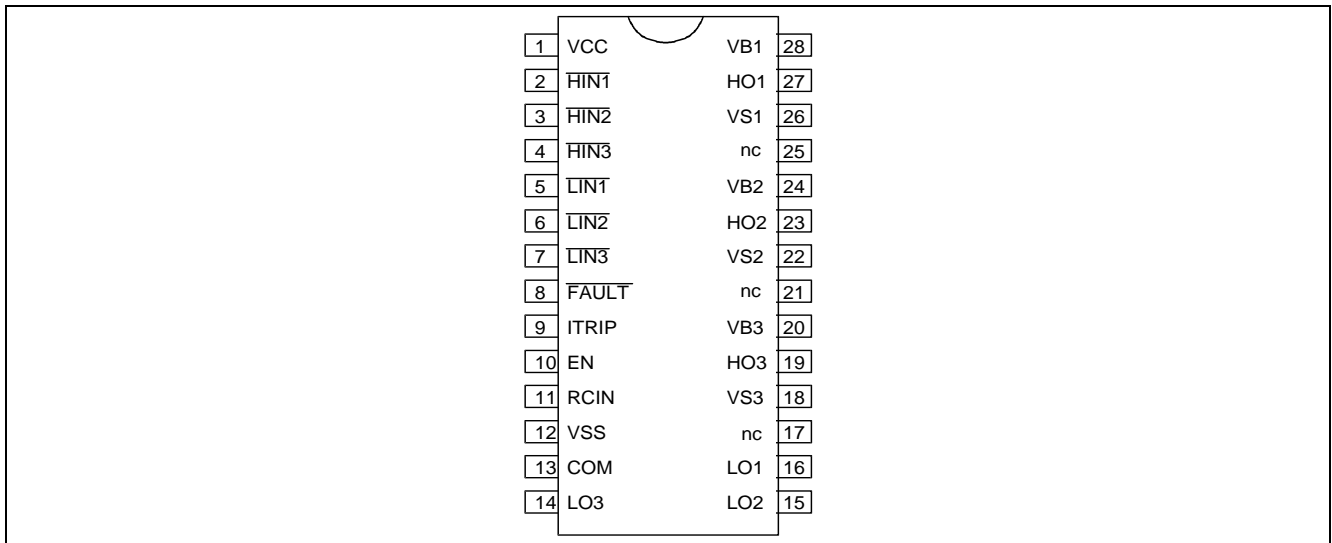

Figure 3 Pin Configuration of 6ED003L06-F2 and 6ED003L02-F2

Table 2 Pin Description

Symbol	Description
VCC	Low side power supply
VSS	Logic ground
/HIN1,2,3	High side logic input
/LIN1,2,3	Low side logic input
/FAULT	Indicates over-current and under-voltage (negative logic, open-drain output)
EN	Enable I/O functionality (positive logic)
ITRIP	Analog input for over-current shut down, activates FAULT and RCIN to VSS
RCIN	External RC-network to define FAULT clear delay after FAULT-Signal ( $T_{FLTCLR}$ )
COM	Low side gate driver reference
VB1,2,3	High side positive power supply
HO1,2,3	High side gate driver output
VS1,2,3	High side negative power supply
LO1,2,3	Low side gate driver output
nc	Not connected

#### 3.1 Low Side and High Side Control Pins (Pin 2, 3, 4, 5, 6, 7)

The Schmitt trigger input threshold of them are such to guarantee LSTTL and CMOS compatibility down to 3.3 V controller outputs. Input Schmitt trigger and noise filter provide beneficial noise rejection to short input pulses according to Figure 4 and Figure 5.

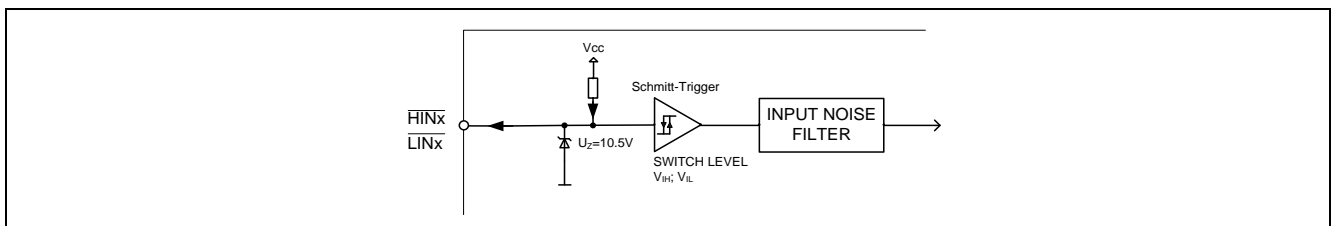
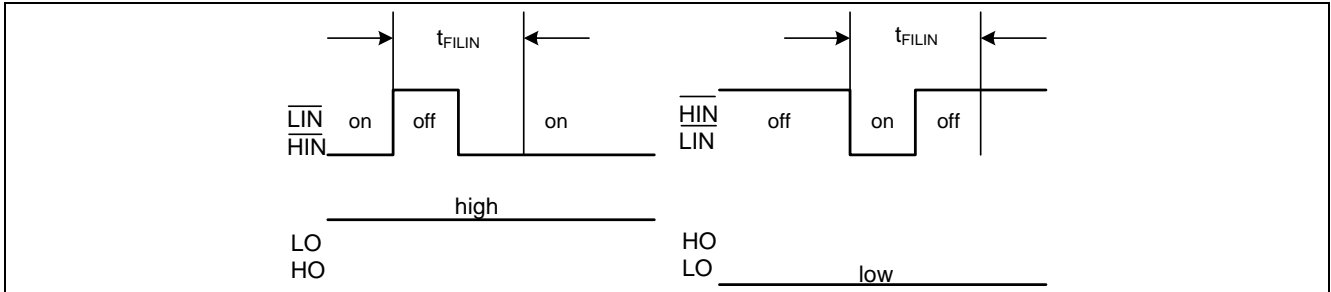

Figure 4 Input pin structure

An internal pull-up of about 75 kΩ (negative logic) pre-biases the input during supply start-up and a ESD zener clamp is provided for pin protection purposes. The zener diodes are therefore designed for single pulse stress only and not for continuous voltage stress over 10V.



**Figure 5** Input filter timing diagram

It is anyway recommended for proper work of the driver not to provide input pulse-width lower than 1 μs.

The 6ED-F2 driver IC provide additionally a shoot through prevention capability which avoids the simultaneous on-state of two channels of the same leg (i.e. HO1 and LO1, HO2 and LO2, HO3 and LO3). When two inputs of a same leg are activated, only one leg output is activated, so that the leg is kept steadily in a safe state.

A minimum dead time insertion of typ. 310 ns is also provided, in order to reduce cross-conduction of the external power switches.

### 3.2 EN (Gate Driver Enable, Pin 10)

The signal applied to pin EN controls directly the output stages. All outputs are set to LOW, if EN is at LOW logic level. The internal structure of the pin is given in Figure 6. The switching levels of the Schmitt-Trigger are here  $V_{EN,TH+} = 2.1$  V and  $V_{EN,TH-} = 1.3$  V. The typical propagation delay time is  $t_{EN} = 780$  ns. There is an internal pull down resistor (75 kΩ), which keeps the gate outputs off in case of broken PCB connection.

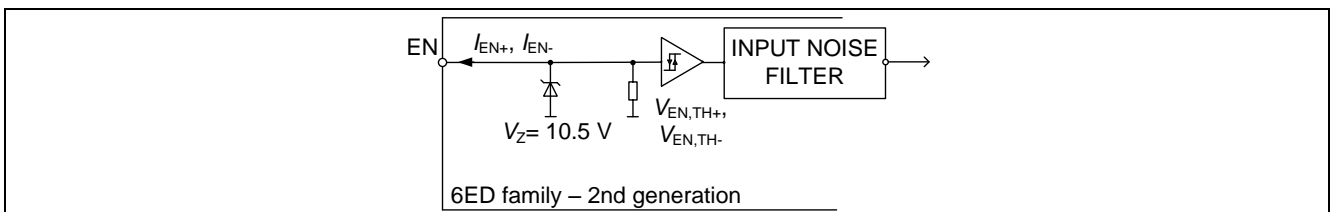
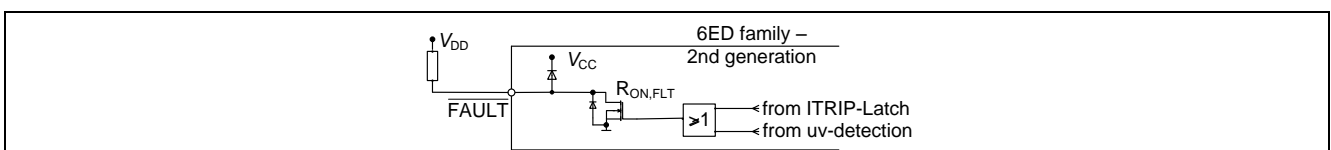

**Figure 6** EN pin structures

### 3.3 /FAULT (Fault Feedback, Pin 8)

/Fault pin is an active low open-drain output indicating the status of the gate driver (see Figure 7). The pin is active (i.e. forces LOW voltage level) when one of the following conditions occur:

- Under-voltage condition of VCC supply: In this case the fault condition is released as soon as the supply voltage condition returns in the normal operation range (please refer to VCC pin description for more details).
- Over-current detection (ITRIP): The fault condition is latched until current trip condition is finished and RCIN input is released (please refer to ITRIP pin).



**Figure 7** /FAULT pin structures



### 3.4 ITRIP and RCIN (Over-Current Detection Function, Pin 9, 11)

The 6ED family – 2<sup>nd</sup> generation provides an over-current detection function by connecting the ITRIP input with the motor current feedback. The ITRIP comparator threshold (typ 0.44 V) is referenced to VSS ground. A input noise filter (typ.  $t_{TRIPMIN} = 230$  ns) prevents the driver to detect false over-current events.

Over-current detection generates a hard shut down of all outputs of the gate driver and provides a latched fault feedback at /FAULT pin. RCIN input/output pin is used to determine the reset time of the fault condition. As soon as ITRIP threshold is exceeded the external capacitor connected to RCIN is fully discharged. The capacitor is then recharged by the RCIN current generator when the over-current condition is finished. As soon as RCIN voltage exceeds the rising threshold of typ  $V_{RCIN,TH} = 5.2$  V, the fault condition releases and the driver returns operational following the control input pins according to section 3.1.

### 3.5 VCC, VSS and COM (Low Side Supply, Pin 1, 12,13)

VCC is the low side supply and it provides power both to input logic and to low side output power stage. Input logic is referenced to VSS ground as well as the under-voltage detection circuit. Output power stage is referenced to COM ground. COM ground is floating respect to VSS ground with a maximum range of operation of +/-5.7 V. A back-to-back zener structure protects grounds from noise spikes.

The under-voltage circuit enables the device to operate at power on when a typical supply voltage higher than  $V_{CCUV+}$  is present.

The IC shuts down all the gate drivers power outputs, when the VCC supply voltage is below  $V_{CCUV-} = 9.8$  V. This prevents the external power switches from critically low gate voltage levels during on-state and therefore from excessive power dissipation. Please consult the individual output characteristic of the driven transistor.

### 3.6 VB1,2,3 and VS1,2,3 (High Side Supplies, Pin 18, 20, 22, 24, 26, 28)

VB to VS is the high side supply voltage. The high side circuit can float with respect to VSS following the external high side power device emitter/source voltage. Due to the low power consumption, the floating driver stage can be supplied by bootstrap topology connected to VCC. The device operating area as a function of the supply voltage is given in Figure 12.

### 3.7 LO1,2,3 and HO1,2,3 (Low and High Side Outputs, Pin 14, 15, 16, 19, 23, 27)

Low side and high side power outputs are specifically designed for pulse operation such as gate drive of IGBT and MOSFET devices. Low side outputs (i.e. LO1,2,3) are state triggered by the respective inputs, while high side outputs (i.e. HO1,2,3) are edge triggered by the respective inputs. In particular, after an under voltage condition of the VBS supply, a new turn-on signal (edge) is necessary to activate the respective high side output, while after a under voltage condition of the VCC supply, the low side outputs switch to the state of their respective inputs.

## 4 Electrical Parameters

### 4.1 Absolute Maximum Ratings

All voltages are absolute voltages referenced to  $V_{SS}$  -potential unless otherwise specified. All parameters are valid for  $T_a=25\text{ °C}$ .

**Table 3 Abs. maximum ratings**

Parameter		Symbol	Min.	Max.	Unit
High side offset voltage(Note 1)	DSO28 TSSOP28	$V_S$	$V_{CC}-V_{BS}-6$	600 180	V
High side offset voltage ( $t_p < 500\text{ns}$ , Note 1)			$V_{CC} - V_{BS} - 50$	–	
High side offset voltage(Note 1)	DSO28 TSSOP28	$V_B$	$V_{CC} - 6$	620 200	
High side offset voltage ( $t_p < 500\text{ns}$ , Note 1)			$V_{CC} - 50$	–	
High side floating supply voltage ( $V_B$ vs. $V_S$ ) (internally clamped)		$V_{BS}$	-1	20	
High side output voltage ( $V_{HO}$ vs. $V_S$ )		$V_{HO}$	-0.5	$V_B + 0.5$	
Low side supply voltage (internally clamped)		$V_{CC}$	-1	20	
Low side supply voltage ( $V_{CC}$ vs. $V_{COM}$ )		$V_{CCOM}$	-0.5	25	
Gate driver ground		$V_{COM}$	-5.7	5.7	
Low side output voltage ( $V_{LO}$ vs. $V_{COM}$ )		$V_{LO}$	-0.5	$V_{CCOM} + 0.5$	
Input voltage /LIN, /HIN, EN, ITRIP		$V_{IN}$	-1	10	
FAULT output voltage		$V_{FLT}$	-0.5	$V_{CC} + 0.5$	
RCIN output voltage		$V_{RCIN}$	-0.5	$V_{CC} + 0.5$	
Power dissipation (to package) Note 2	DSO28 TSSOP28	$P_D$	– –	1.3 0.6	
Thermal resistance (junction to ambient, see section 6)	DSO28 TSSOP28	$R_{th(j-a)}$	– –	75 165	
Junction temperature		$T_J$	–	125	°C
Storage temperature		$T_S$	- 40	150	
offset voltage slew rate (Note 3)		$dV_S/dt$		50	V/ns

Note :The value for ESD immunity is 1.0kV (Human Body Model). ESD immunity for pins inside the low side (i.e.  $V_{CC}$ , /HINx, /LINx, FAULT, EN, RCIN, ITRIP, VSS, COM, LOx) and ESD immunity for pins inside each high side itself (i.e.  $V_B$ , HOx, VSx) is guaranteed up to 1.5kV (Human Body Model).

Note 1 : Insensitivity of bridge output to negative transient voltage up to  $-50\text{V}$  is not subject to production test – verified by design / characterization. External bootstrap diode is mandatory. Refer to application note.

Note 2: Consistent power dissipation of all outputs. All parameters inside operating range.

Note 3: Not subject of production test, verified by characterisation

## 4.2 Required operation conditions

All voltages are absolute voltages referenced to  $V_{SS}$  -potential unless otherwise specified. All parameters are valid for  $T_a=25$  °C.

**Table 4 Required Operation Conditions**

Parameter		Symbol	Min.	Max.	Unit
High side offset voltage (Note 1)	DSO28 TSSOP28	$V_B$	7	620 200	V
Low side supply voltage ( $V_{CC}$ vs. $V_{COM}$ )	DSO28 TSSOP28	$V_{CCOM}$	10	25	

## 4.3 Operating Range

All voltages are absolute voltages referenced to  $V_{SS}$  -potential unless otherwise specified. ( $T_a = 25$ °C)

**Table 5 Operating range**

Parameter	Symbol	Min.	Max.	Unit	
High side floating supply offset voltage	$V_S$	$V_{CC} - V_{BS} - 1$	500	V	
High side floating supply offset voltage ( $V_B$ vs. $V_{CC}$ , statically)	$V_{BCC}$	-1.0	500		
High side floating supply voltage ( $V_B$ vs. $V_S$ , Note 1)	$V_{BS}$	13	17.5		
High side output voltage ( $V_{HO}$ vs. $V_S$ )	$V_{HO}$	0	$V_{BS}$		
Low side output voltage ( $V_{LO}$ vs. $V_{COM}$ )	$V_{LO}$	0	$V_{CC}$		
Low side supply voltage	$V_{CC}$	13	17.5		
Low side ground voltage	$V_{COM}$	-2.5	2.5		
Logic input voltages /LIN, /HIN, EN, ITRIP (Note 2)	$V_{IN}$	0	5		
FAULT output voltage	$V_{FLT}$	0	$V_{CC}$		
RCIN input voltage	$V_{RCIN}$	0	$V_{CC}$		
Pulse width for ON or OFF (Note 3)	$t_{IN}$	1	–		µs
Ambient temperature	$T_a$	-40	105		°C

Note 1 : Logic operational for  $V_B$  ( $V_B$  vs.  $V_{SS}$ ) > 7,0V

Note 2 : All input pins (/HINx, /LINx) and EN, ITRIP pin are internally clamped (see abs. maximum ratings)

Note 3 : In case of input pulse width at /LINx and /HINx below 1µs the input pulse may not be transmitted properly

#### 4.4 Static logic function table

VCC	VBS	RCIN	ITRIP	ENABLE	FAULT	LO1,2,3	HO1,2,3
<V <sub>CCUV-</sub>	X	X	X	X	0	0	0
15V	<V <sub>BSUV-</sub>	X	0	3.3 V	High imp	/LIN1,2,3	0
15V	15V	<3.2 V ↓	0	3.3 V	0	0	0
15V	15V	X	> V <sub>IT,TH+</sub>	3.3 V	0	0	0
15V	15V	> V <sub>RCIN,TH</sub>	0	3.3 V	High imp	/LIN1,2,3	/HIN1,2,3
15V	15V	> V <sub>RCIN,TH</sub>	0	0	High imp	0	0

#### 4.5 Static parameters

V<sub>CC</sub> = V<sub>BS</sub> = 15V unless otherwise specified. All parameters are valid for T<sub>a</sub>=25 °C.

**Table 6** Static parameters

Parameter	Symbol	Values			Unit	Test condition
		Min.	Typ.	Max.		
High level input voltage	V <sub>IH</sub>	1.7	2.1	2.4	V	
Low level input voltage	V <sub>IL</sub>	0.7	0.9	1.1		
EN positive going threshold	V <sub>EN,TH+</sub>	1.9	2.1	2.3		
EN negative going threshold	V <sub>EN,TH-</sub>	1.1	1.3	1.5		
ITRIP positive going threshold	V <sub>IT,TH+</sub>	380	445	510	mV	
ITRIP input hysteresis	V <sub>IT,HYS</sub>	45	70			
RCIN positive going threshold	V <sub>RCIN,TH</sub>	-	5.2	6.4	V	
RCIN input hysteresis	V <sub>RCIN,HYS</sub>	-	2.0	-		
Input clamp voltage (/HIN, /LIN, EN, ITRIP)	V <sub>IN,CLMAP</sub>	9	10.3	12		I <sub>IN</sub> = 4mA
Input clamp voltage at high impedance (/HIN, /LIN)	V <sub>IN,FLOAT</sub>	-	5.3	5.8		controller output pin floating
High level output voltage	LO1,2,3 HO1,2,3	V <sub>OH</sub>	-	V <sub>CC</sub> -0.7 V <sub>B</sub> -0.7	V <sub>CC</sub> -1.4 V <sub>B</sub> -1.4	I <sub>O</sub> = 20mA
Low level output voltage	LO1,2,3 HO1,2,3	V <sub>OL</sub>	-	V <sub>COM+</sub> 0.2 V <sub>S</sub> + 0.2	V <sub>COM+</sub> 0.6 V <sub>S</sub> + 0.6	I <sub>O</sub> = -20mA
V <sub>CC</sub> and V <sub>BS</sub> supply undervoltage positive going threshold	V <sub>CCUV+</sub> V <sub>BSUV+</sub>	11	11.7	12.5		
V <sub>CC</sub> and V <sub>BS</sub> supply undervoltage negative going threshold	V <sub>CCUV-</sub> V <sub>BSUV-</sub>	9.5	9.8	10.8	V	
V <sub>CC</sub> and V <sub>BS</sub> supply undervoltage lockout hysteresis	V <sub>CCUVH</sub> V <sub>BSUVH</sub>	1.2	1.9	-		

**Table 6 Static parameters**

Parameter	Symbol	Values			Unit	Test condition
		Min.	Typ.	Max.		
High side leakage current betw. VS and VSS	$I_{LVS+}$	-	1	12.5	$\mu\text{A}$	$V_S = 600\text{V}$
High side leakage current betw. VS and VSS	$I_{LVS+}^1$	-	10	-		$T_J = 125^\circ\text{C}$ , $V_S = 600\text{V}$
High side leakage current between VSx and VSy (x=1,2,3 and y=1,2,3)	$I_{LVS-}^1$	-	10	-		$T_J = 125^\circ\text{C}$ $V_{Sx} - V_{Sy} = 600\text{V}$
Quiescent current $V_{BS}$ supply (VB only)	$I_{QBS1}$	-	210	400	$\mu\text{A}$	HO=low
Quiescent current $V_{BS}$ supply (VB only)	$I_{QBS2}$	-	210	400		HO=high
Quiescent current $V_{CC}$ supply (VCC only)	$I_{QCC1}$	-	1.1	1.8	$\text{mA}$	$V_{LIN}=\text{float.}$
Quiescent current $V_{CC}$ supply (VCC only)	$I_{QCC2}$	-	1.3	2		$V_{LIN}=0$ , $V_{HIN}=3.3\text{ V}$
Input bias current	$I_{LIN+}$	-	70	100	$\mu\text{A}$	$V_{LIN}=3.3\text{ V}$
Input bias current	$I_{LIN-}$	-	110	200	$\mu\text{A}$	$V_{LIN}=0$
Input bias current	$I_{HIN+}$	-	70	100		$V_{HIN}=3.3\text{ V}$
Input bias current	$I_{HIN-}$	-	110	200		$V_{HIN}=0$
Input bias current (ITRIP=high)	$I_{ITRIP+}$		45	120		$V_{ITRIP}=3.3\text{ V}$
Input bias current (EN=high)	$I_{EN+}$	-	45	120		$V_{ENABLE}=3.3\text{ V}$
Input bias current RCIN (internal current source)	$I_{RCIN}$		2.8			$V_{RCIN} = 2\text{ V}$
Mean output current for load capacity charging in range from 3 V (20%) to 6 V (40%)	$I_{O+}$	120	165	-	$\text{mA}$	$C_L=10\text{ nF}$
Peak output current turn on (single pulse)	$I_{Opk+}^1$		240			$R_L = 0\ \Omega$ , $t_p < 10\ \mu\text{s}$
Mean output current for load capacity discharging in range from 12 V (80%) to 9 V (60%)	$I_{O-}$	250	375	-		$C_L=10\text{ nF}$
Peak output current turn off (single pulse)	$I_{Opk-}^1$		420			$R_L = 0\ \Omega$ , $t_p < 10\ \mu\text{s}$
RCIN low on resistance of the pull down transistor	$R_{on,RCIN}$	-	40	100		$V_{RCIN}=0.5\text{ V}$
FAULT low on resistance of the pull down transistor	$R_{on,FLT}$	-	45	100		$V_{FAULT}=0.5\text{ V}$

<sup>1</sup> Not subject of production test, verified by characterisation

## 4.6 Dynamic parameters

$V_{CC} = V_{BS} = 15\text{ V}$ ,  $V_S = V_{SS} = V_{COM}$  unless otherwise specified. All parameters are valid for  $T_a=25\text{ }^\circ\text{C}$ .

**Table 7** Dynamic parameters

Parameter	Symbol	Values			Unit	Test condition
		Min.	Typ.	Max.		
Turn-on propagation delay	$t_{on}$	400	530	800	ns	$V_{LIN/HIN} = 0$ or $3.3\text{ V}$
Turn-off propagation delay	$t_{off}$	360	490	760		
Turn-on rise time	$t_r$	-	60	100		
Turn-off fall time	$t_f$	-	26	45		
Shutdown propagation delay ENABLE	$t_{EN}$	-	780	1100		
Shutdown propagation delay ITRIP	$t_{ITRIP}$	400	670	1000		
Input filter time ITRIP	$t_{ITRIPMIN}$	155	230	380		
Propagation delay ITRIP to FAULT	$t_{FLT}$	-	420	700		
Input filter time at LIN/HIN for turn on and off	$t_{FILIN}$	120	300	-		
Input filter time EN	$t_{FILEN}$	300	600	-		
Fault clear time at RCIN after ITRIP-fault, ( $C_{RCin}=1\text{ nF}$ )	$t_{FLTCLR}$	1.0	1.9	3.0	ms	$V_{LIN/HIN} = 0$ & $3.3\text{ V}$ $V_{ITRIP} = 0$
Dead time	DT	150	310	-	ns	$V_{LIN/HIN} = 0$ & $3.3\text{ V}$
Matching delay ON, max(ton)-min(ton), ton are applicable to all 6 driver outputs	$MT_{ON}$	-	20	100		
Matching delay OFF, max(toff)-min(toff), toff are applicable to all 6 driver outputs	$MT_{OFF}$	-	40	100		
Output pulse width matching. $PW_{in}-PW_{out}$	PM		40	100		

## 5 Timing diagrams

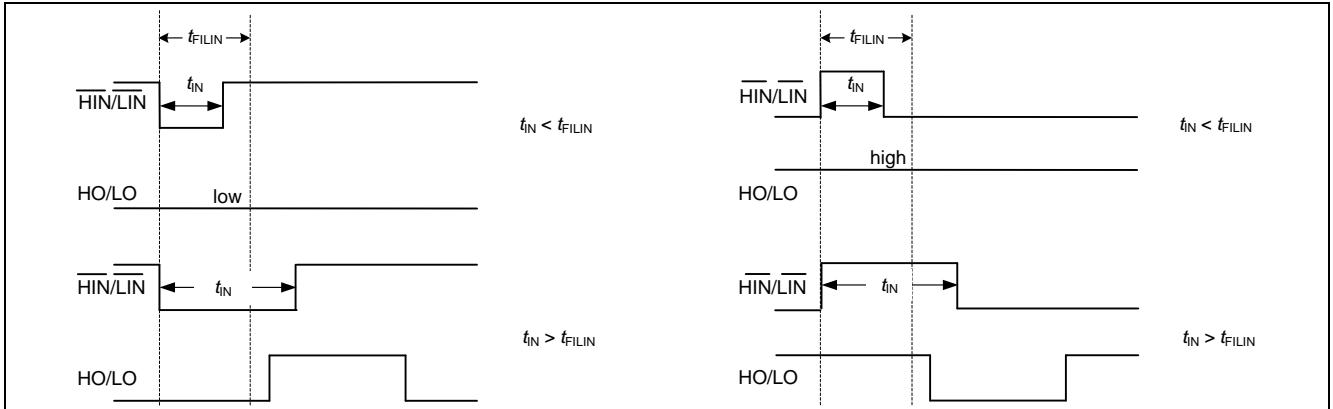

Figure 8 Timing of short pulse suppression

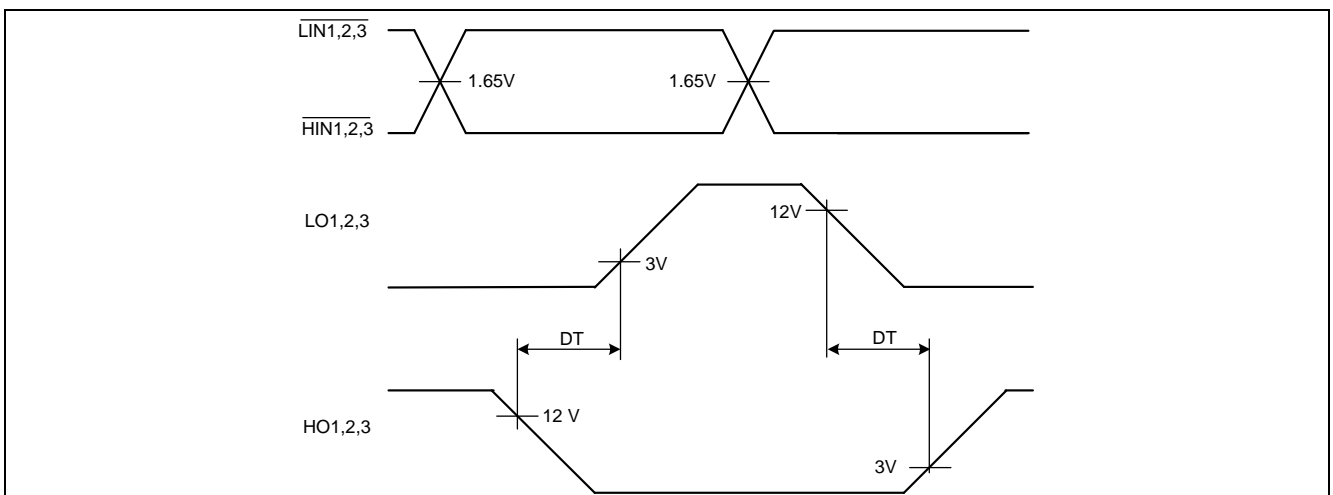

Figure 9 Timing of internal deadtime

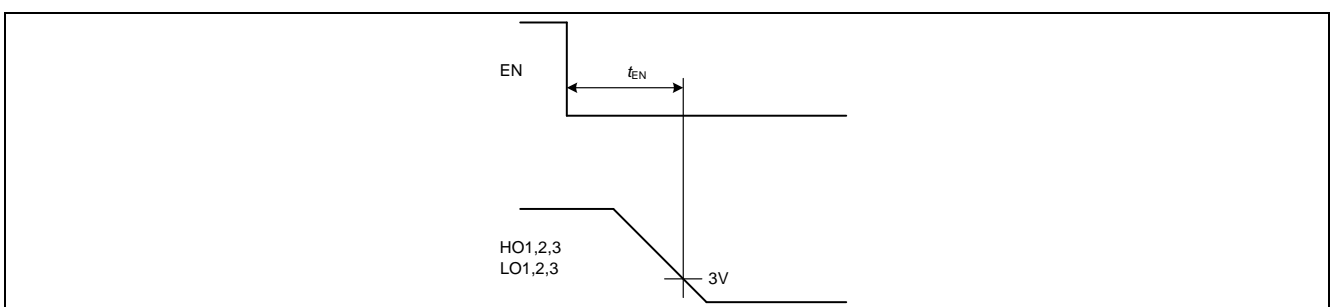

Figure 10 Enable delay time definition

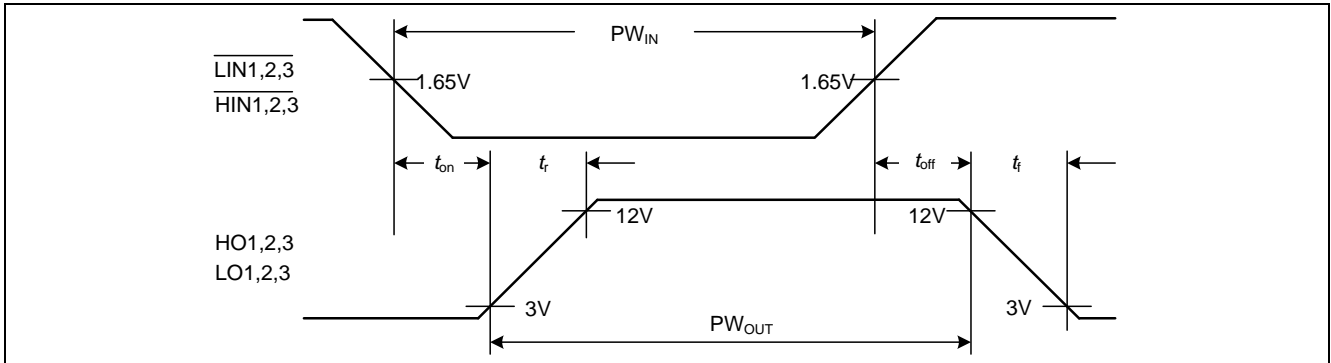

Figure 11 Input to output propagation delay times and switching times definition

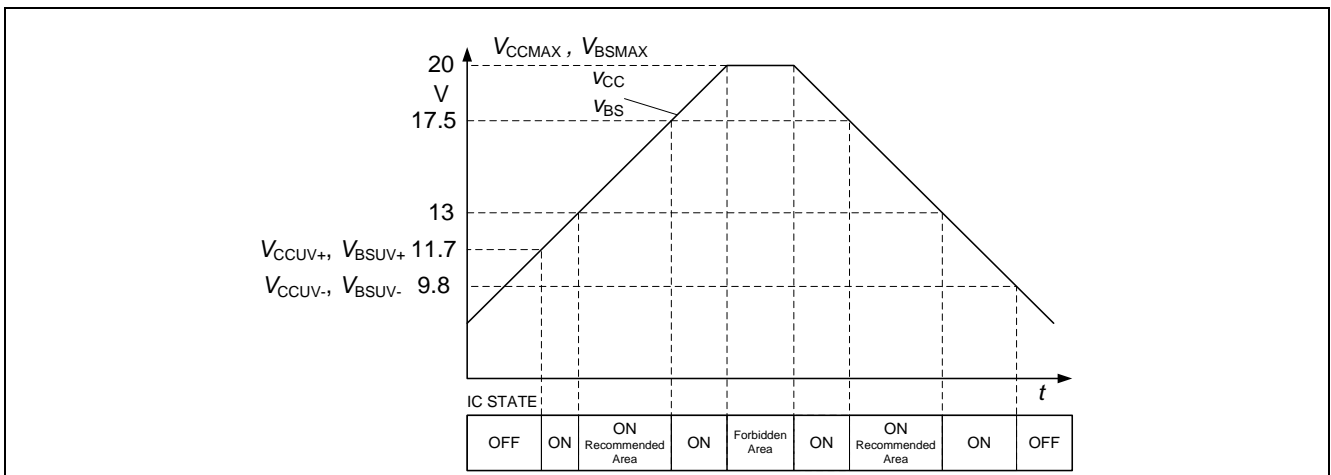

Figure 12 Operating areas

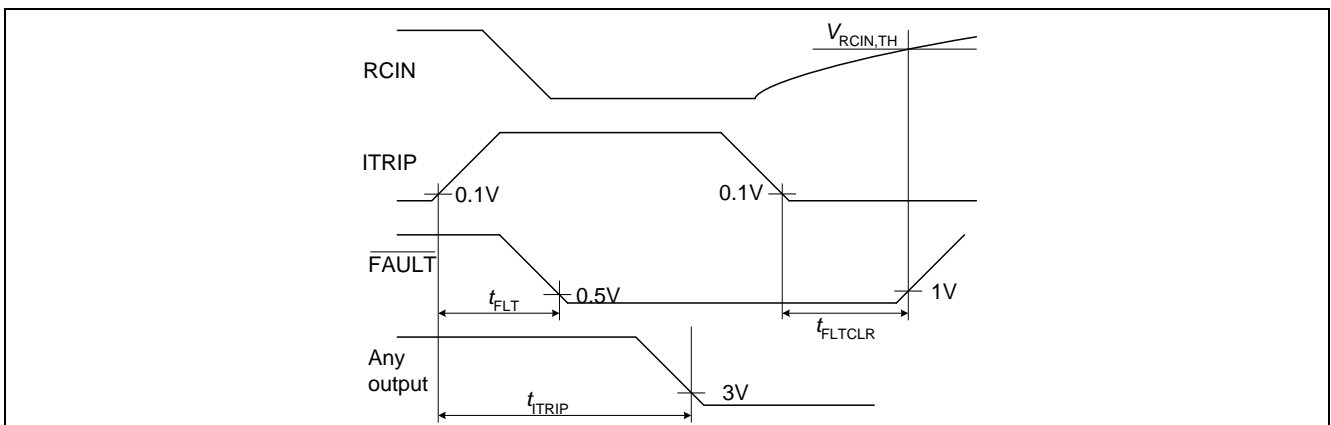

Figure 13 ITRIP-Timing



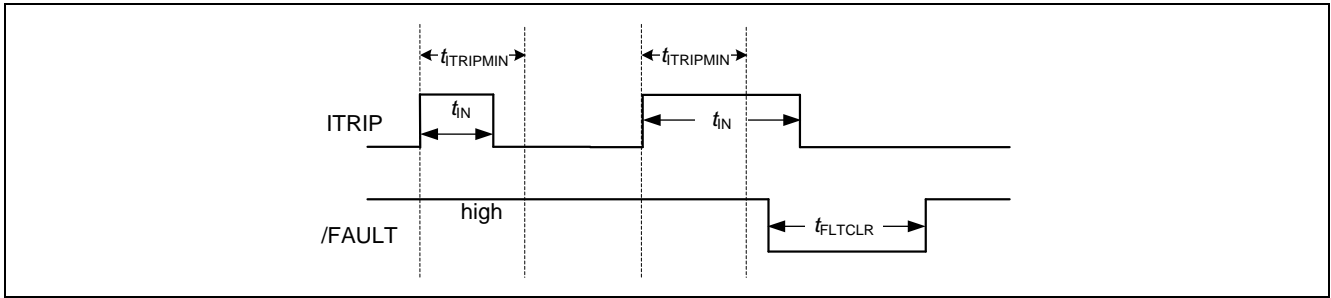

Figure 14 ITRIP input filter time

## 6 Package

### 6.1 PG-DSO-28

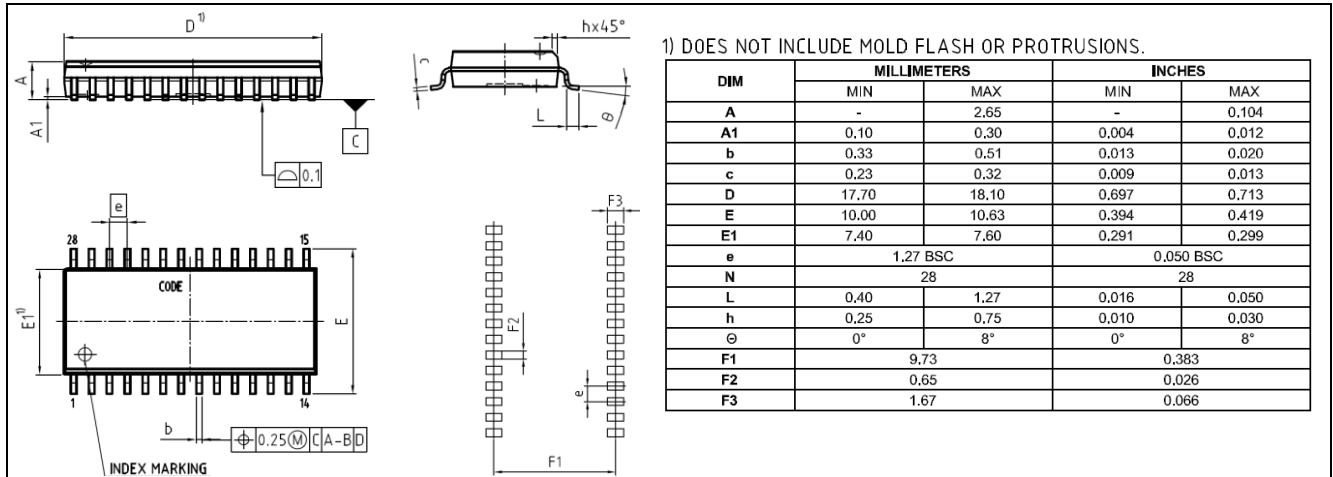

Figure 15 Package drawing

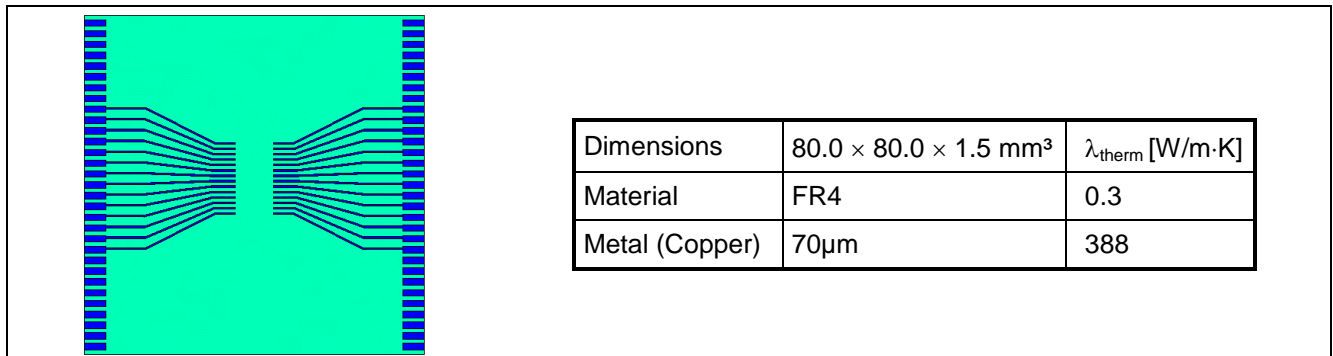

Figure 16 PCB reference layout

6.2 PG-TSSOP-28

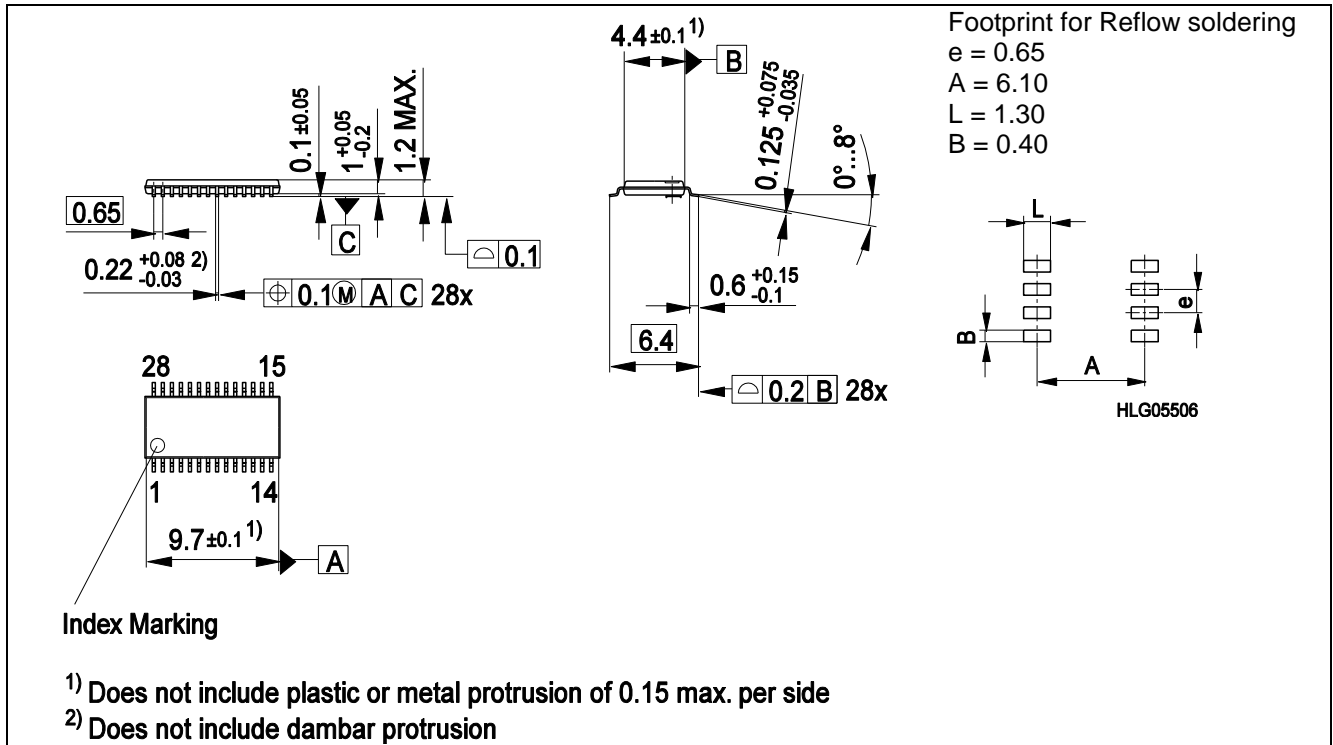

Figure 17 Package drawing

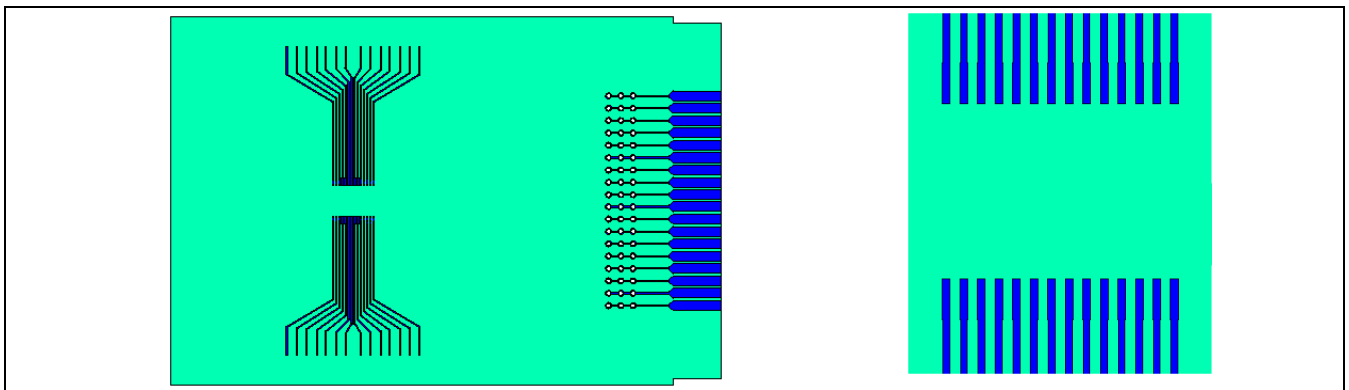

Figure 18 PCB reference layout (according to JEDEC 1s0P)  
 left: Reference layout  
 right: detail of footprint

Table 8 Data of reference layout

Dimensions	Material	Metal (Copper)
$76.2 \times 114.3 \times 1.5 \text{ mm}^3$	FR4 ( $\lambda_{\text{therm}} = 0.3 \text{ W/mK}$ )	70 $\mu\text{m}$ ( $\lambda_{\text{therm}} = 388 \text{ W/mK}$ )

[www.infineon.com](http://www.infineon.com)

Published by Infineon Technologies AG

# Mouser Electronics

Authorized Distributor

Click to View Pricing, Inventory, Delivery & Lifecycle Information:

[Infineon:](#)

[6ED003L06-F](#) [6ED003L06F2XUMA1](#) [6ED003L02F2XUMA1](#) [6ED003L06-F2](#) [6ED003L02-F2](#) [6ED003L02-F](#)