

# Molded Parts Specification Control Drawing

Part Number : 301A511 thru 514  
Description : Slimline Transition, "T"

## NOTES

- All dimensions are in  $\frac{\text{inches}}{\text{[millimeters]}}$
- Dimensions appearing in table are as follows:
  - As Supplied
  - After Unrestricted Recovery
- Coating is optional. As supplied dimensions appearing in table are for uncoated parts. When coating is added, entry diameters will be reduced by .06 max.

**⚠** Part 301A514 is not available in -125 and -780 material.

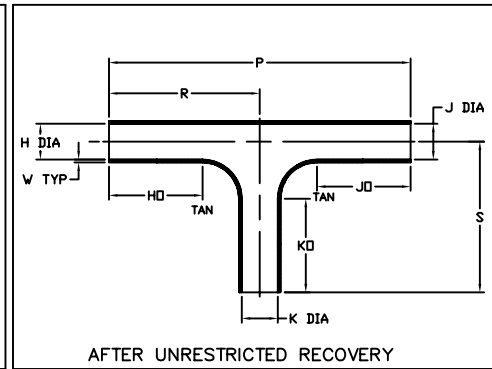
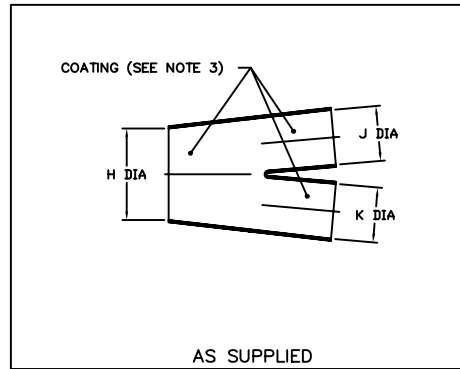

PART NUMBER	H		J & K		HO, JO & KO ±10% b	W Nom b	P Nom b	R & S Nom b
	Min a	Max b	Min a	Max b				
301A511	.78 [19,8]	.26 [6,6]	.52 [13,2]	.26 [6,6]	1.00 [25,4]	.04 [1,0]	3.18 [80,8]	1.59 [40,4]
301A512	1.35 [34,3]	.45 [11,4]	.90 [22,9]	.45 [11,4]	1.62 [41,1]	.05 [1,3]	4.74 [120,4]	2.37 [60,2]
301A513	2.37 [60,2]	.79 [20,1]	1.58 [40,1]	.79 [20,1]	2.50 [63,5]	.06 [1,5]	6.92 [175,8]	3.46 [87,9]
301A514	3.28 [83,3]	1.31 [33,3]	2.16 [54,9]	1.31 [33,3]	3.50 [88,9]	.07 [1,78]	9.54 [242,3]	4.77 [121,2]

**tyco** **Raychem**  
**Electronics**  
TYCO ELECTRONICS  
300 CONSTITUTION DRIVE  
MENLO PARK, CALIFORNIA 94025

Revision : R  
Date : 2/17/05

Part Number : 301A511 thru 514  
Description : Slimline Transition, "T"

# Molded Parts Specification Control Drawing

Part Number : 301A511 thru 514  
Description : Slimline Transition, "T"

MATERIAL DASH NO.	MATERIAL DESCRIPTION	RT SPEC	COATING SLASH NO.	COATING S NO.	COATING DESCRIPTION
-50	Flexible VPB	RT-1313	N/A		
-51	Flexible EPB	RT-1321	/164	S-1124	Adhesive
-71	Flexible Polyolefin	RT-1316	/42,86	S-1017;S-1048	Adhesive
-125	Modified Fluoropolymer	RT-1334	N/A		
-770	NBCCS	RT-770 TYPE II	N/A		
-780	NBCCS	RT-780 TYPE II	N/A		

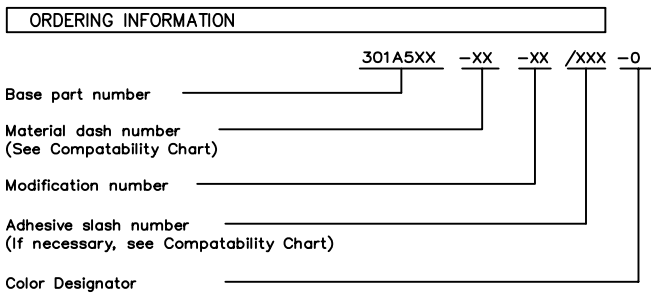

THIS DRAWING IS SUBJECT TO CHANGE WITHOUT NOTICE; CONSULT YOUR NEAREST FIELD REPRESENTATIVE FOR CURRENT REVISION

**tyco** **Raychem**  
**Electronics**  
TYCO ELECTRONICS  
300 CONSTITUTION DRIVE  
MENLO PARK, CALIFORNIA 94025

Revision : R  
Date : 2/17/05

Part Number : 301A511 thru 514  
Description : Slimline Transition, "T"

If this document is printed it becomes uncontrolled.  
Check for the latest revision.

# Mouser Electronics

Authorized Distributor

Click to View Pricing, Inventory, Delivery & Lifecycle Information:

[TE Connectivity:](#)

[301A511-71/42-0](#)