

RDS180-24

SPECIFICATIONS

B030-01-01A

ITEMS		MODEL	RDS180-24-5	RDS180-24-12	RDS180-24-15	RDS180-24-24
1	Nominal Output Voltage	V	5	12	15	24
2	Maximum Output Current	A	36	15	12	7.5
3	Maximum Output Power	W	180	180	180	180
4	Efficiency (Typ) (*1)	%	78	79		80
5	Input Voltage Range	-	18 - 32VDC			
6	Input Current (Typ) (*1)	A	9.6			
7	Inrush Current (Typ) (*1)	-	30A at Cold Start			
8	Output Voltage Range (*8)	V	4.0 - 6.0	9.6 - 14.4	12.0 - 18.0	19.2 - 28.8
9	Maximum Ripple (*2)	mV	50	80	80	100
10	Maximum Ripple & Noise (*2)	mV	100	170	200	290
11	Maximum Line Regulation (*3)	mV	40	96	120	192
12	Maximum Load Regulation (*4)	mV	50	120	150	240
13	Temperature Coefficient	-	Less than 0.02 %/°C			
14	Over Current Protection (*5)	A	37.8 - 48.6	15.7 - 20.3	12.6 - 16.2	7.8 - 10.2
15	Over Voltage Protection (*6)	V	6.2 - 7.3	15 - 17.4	18.7 - 21.8	30.0 - 34.8
16	Remote ON/OFF control	-	Possible			
17	Parallel Operation	-	Possible			
18	Series Operation	-	Possible			
19	Operating Temperature (*7)	-	-20 - +60°C (-20 - +50°C:100%, +60°C:70%)			
20	Operating Humidity	-	20 - 95%RH (No Condensing)			
21	Storage Temperature	-	-25 - +75°C			
22	Storage Humidity	-	20 - 95%RH (No Condensing)			
23	Cooling	-	Convection Cooling			
24	Withstand Voltage	-	Input - Output, Input - FG : 2kVAC (10mA) for 1min., Output - CNT(RC) : 100VAC (100mA) for 1min.			
25	Isolation Resistance	-	Output - FG : 500VDC more than 100MΩ, Output - CNT(RC) : 100VDC more than 10MΩ			
26	Vibration	-	10 - 55Hz : 19.6m/s ² , X,Y,Z 1hour each. JIS E 3014-2-B			
27	Shock	-	294m/s ² (time : 6±3ms) JIS E 3015-2-B			
28	Safety	-	Approved by UL60950-1 & CSA60950-1, Designed to meet EN60950-1			
29	Conducted Emission	-	Designed to meet EN55011/EN55022-A, FCC-ClassA, VCCI-A			
30	Radiated Emission	-	Designed to meet EN55011/EN55022-A, FCC-ClassA, VCCI-A			
31	Immunity	-	Designed to meet IEC61000-4-2(Level 2,3), -4(Level 3), -8(Level 4)			
32	Weight (Typ)	g	1400			
33	Size (W x H x D)	mm	80 x 95 x 220 (Refer to Outline Drawing)			

*Read instruction manual carefully, before using the power supply unit.

=NOTES=

- *1. At 24VDC, Ta=25°C, nominal output voltage and maximum output power.
- *2. Measure with JEITA RC-9131A probe, Bandwidth of scope :100MHz.
- *3. 18 - 32VDC, constant load.
- *4. No load-Full load, constant input voltage.
- *5. OCP TYPE : Constant current limit with automatic recovery.
- *6. OVP circuit will shut the output down, manual reset (Re power on).
- *7. Ratings
 - Derating at standard mounting. Refer to output derating curve(B030-01-02_).
 - Load (%) is percent of maximum output power or maximum output current, whichever is greater.
- *8. At 24VDC Input.(Refer to instruction manual.)

RDS180-24

OUTPUT DERATING

B030-01-02A

*COOLING : CONVECTION COOLING

Ta (°C)	LOAD (%)	
	MOUNTING A	MOUNTING B
-20 - +40	100	100
50	100	70
60	70	-

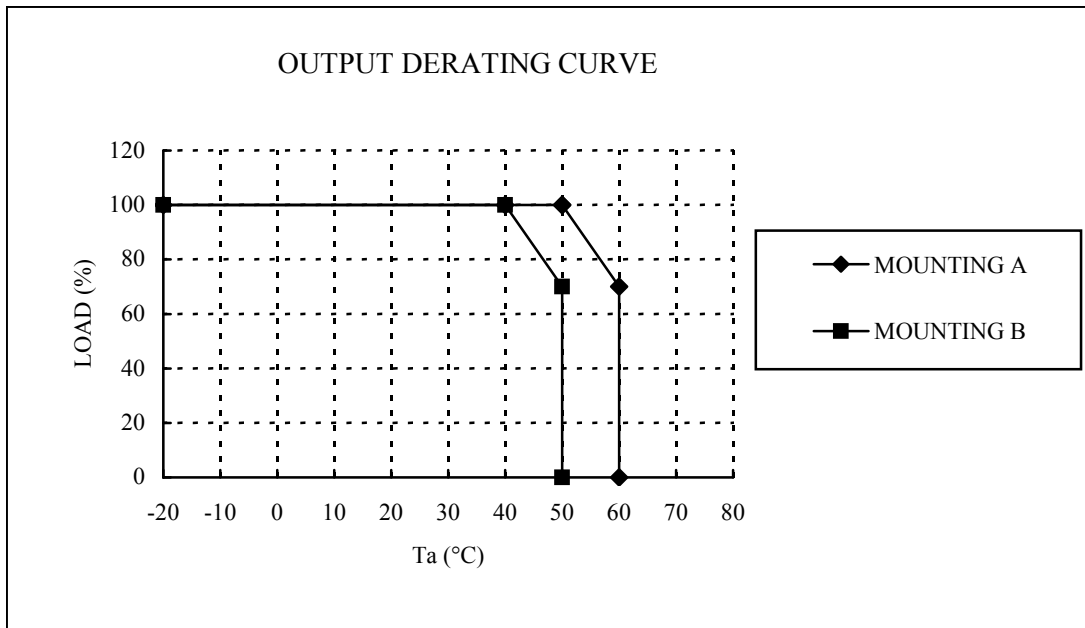

DON'T USE

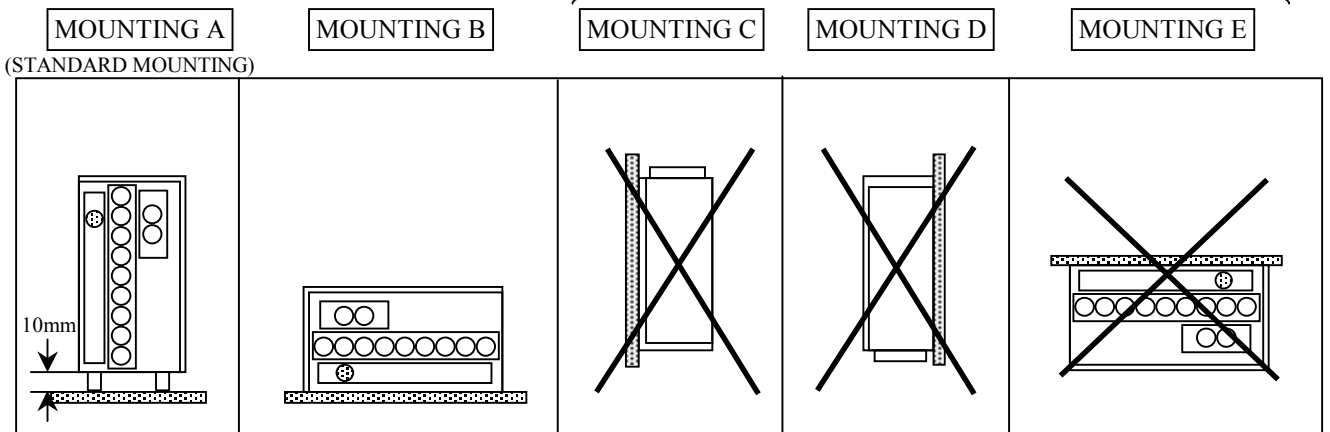

Foot Space for mounting 'A' must be 10mm or higher when having a load larger than 150W.

Mouser Electronics

Authorized Distributor

Click to View Pricing, Inventory, Delivery & Lifecycle Information:

[TDK-Lambda:](#)

[RDS180245](#)