

| REVISIONS | | | |
|-----------|-------------|----------|----------|
| REV. | DESCRIPTION | DATE | APPROVED |
| A | ECO #7797 | 01/05/10 | A.D.M. |

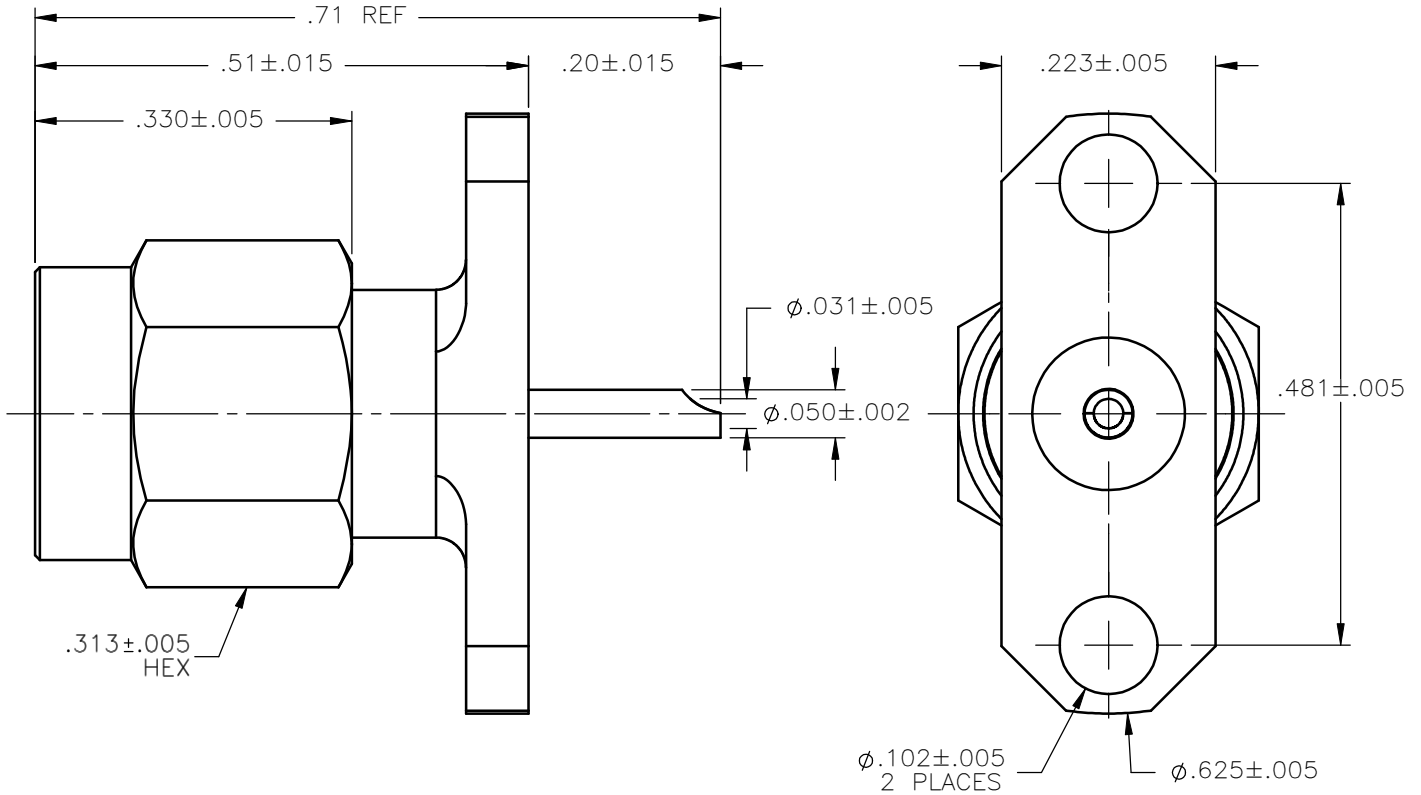

NOTES:

MATERIALS:

1. BODY & COUPLING NUT = STAINLESS STEEL PER ASTM A582, ALLOY 303, CONDITION "A".
2. INSULATOR = VIRGIN WHITE TEFLON PER ASTM D1710, GRADE 1, TYPE I, CLASS "B".
3. CONTACT & RETAINING RING = BERYLLIUM COPPER PER ASTM B196, ALLOY C17300, TEMPER TD04.
4. GASKET = SILICONE RUBBER PER ZZ-R-765, CLASS 2B, GRADE 65-75.

FINISHES:

1. BODY & COUPLING NUT = PASSIVATE PER QQ-P-35, TYPE VI.
2. CONTACT = GOLD PLATE PER MIL-G-45204, TYPE II, CLASS 1, GRADE C, OVER .00010 TO .00020 STRESS FREE SULFAMATE NICKEL PER QQ-N-290.

Property of Radiall Incorporated
 This document cannot be reproduced or
 communicated to a third party without prior
 written permission of RADIALL Incorporated.

| | | | | | |
|---|-----------------------|------------------|--|--------------------------|--------------|
| UNLESS OTHERWISE SPECIFIED DIMENSIONS ARE IN INCHES TOLERANCES ON | DWN: A.D.M. | DATE 01/05/10 |  APPLIED ENGINEERING PRODUCTS 104 John W. Murphy Dr. New Haven, CT 06513 | | |
| | CHKD: D.N. | DATE 01/05/10 | | | |
| DECIMAL | ANGLE | APVD: J.M. | SMA STRAIGHT PLUG 2 HOLE FLANGE MOUNT SOLDER POT CONTACT | | |
| | | DATE 01/05/10 | | | |
| REFERENCE: | MATERIALS & FINISHES: | SIZE A | FSCM NO. 19505 | DWG NO. 9455-9113-000 | REV A |
| ORIGINATED: D.N. DATE: 04/26/96 | SEE NOTES | SCALE 5:1 | THIRD ANGLE PROJECTION | | SHEET 1 OF 1 |

9455-9113-000

Mouser Electronics

Authorized Distributor

Click to View Pricing, Inventory, Delivery & Lifecycle Information:

Radial:

[9455-9113-000](tel:9455-9113-000)