

THIS DRAWING IS UNPUBLISHED. RELEASED FOR PUBLICATION
 © COPYRIGHT - By - ALL RIGHTS RESERVED.

| REVISIONS | | | | |
|-----------|-----|---------------------------|-----------|---------|
| P | LTR | DESCRIPTION | DATE | APVD |
| F2 | | REVISED PER ECR-17-014071 | 30DEC2017 | W.H D.Z |

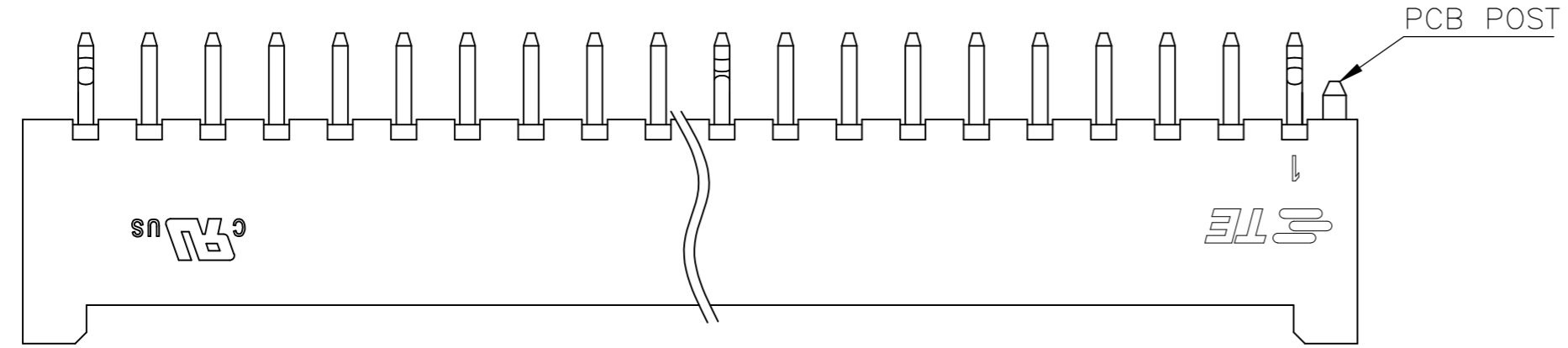

- 1 MATERIAL: HIGH PERFORMANCE RESIN, UL94 V0, COLOR: NATURAL.
- 2 CONTACT RETENTION: 12 NEWTON [2.7 lbf] MIN.
- 3 CONTACT SOLDERTAIL KINK DIRECTION SEE BELOW TABLE.

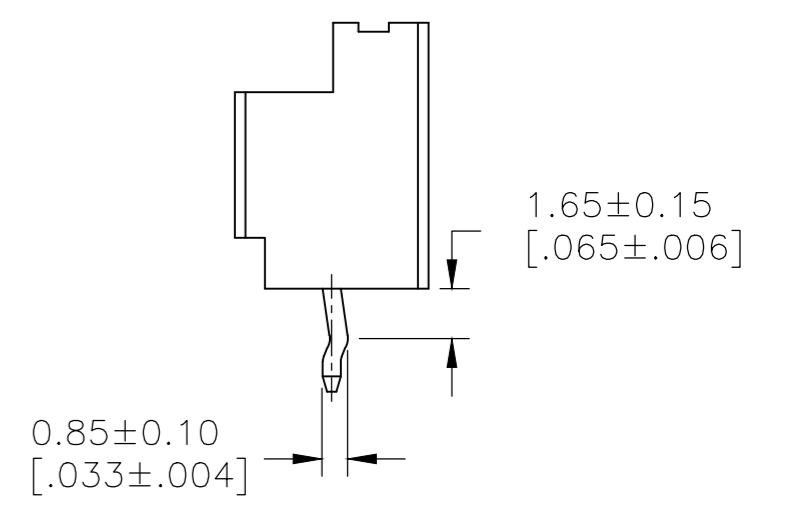
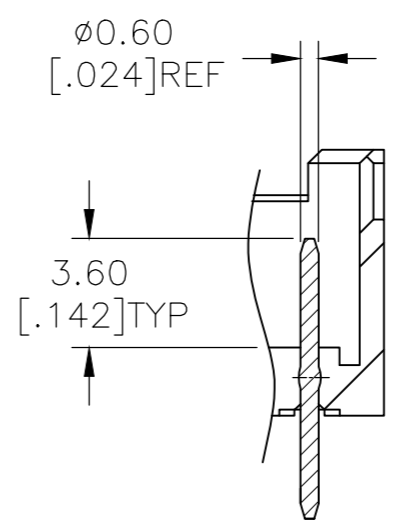
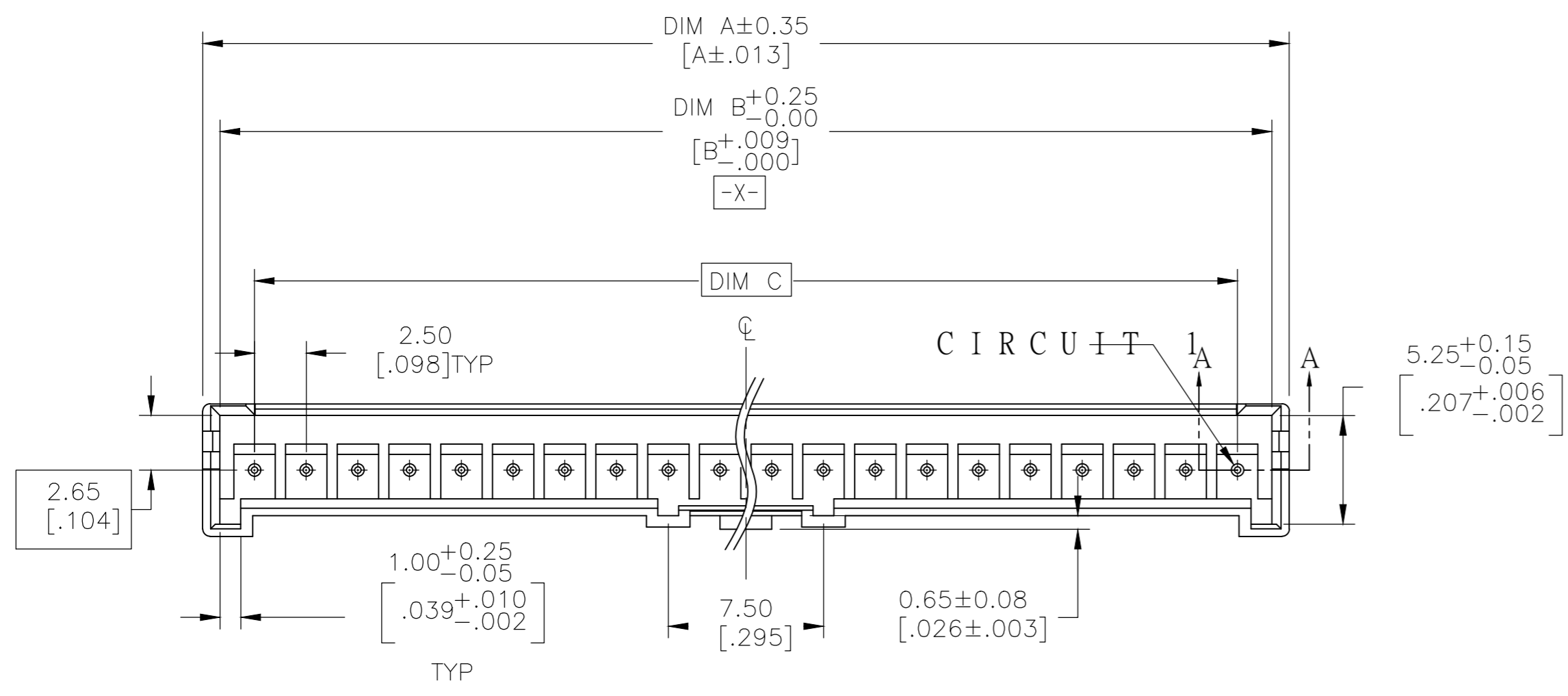

SECTION A - A

MIDDLE

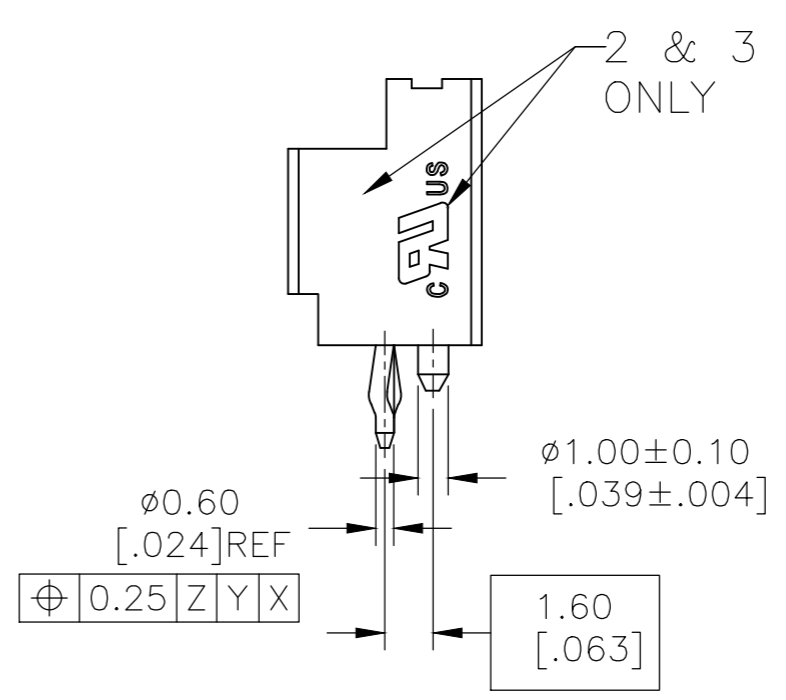
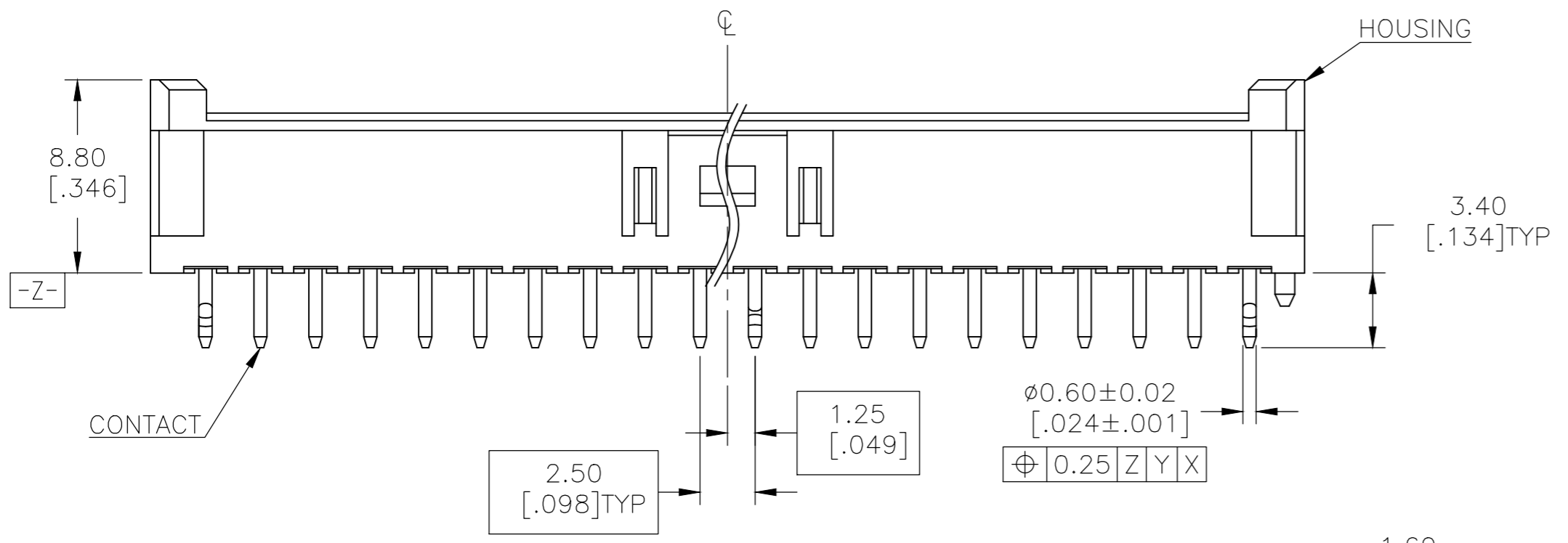

SIDE

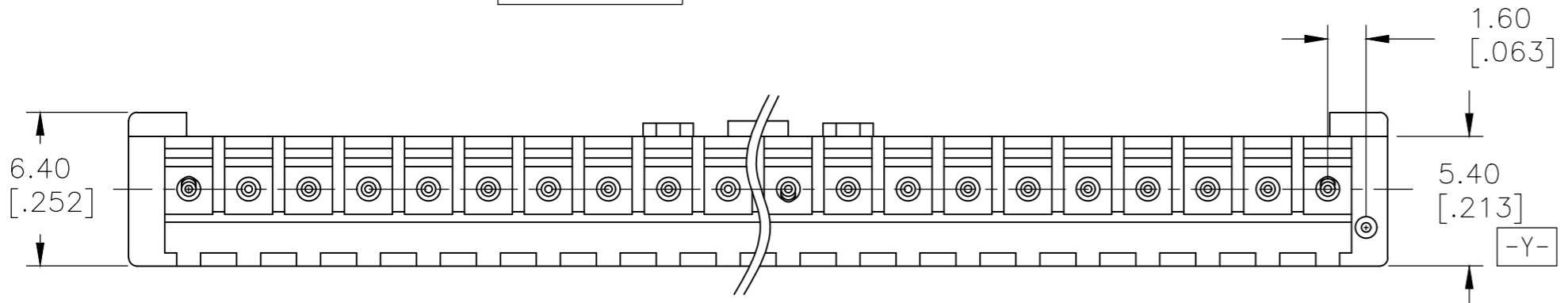

| | | | | |
|--|--------------|--------------------------|----------------------|-----------------|
| THIS DRAWING IS A CONTROLLED DOCUMENT. | | DWN RAGHAVENDRA 06JAN11 | TE Connectivity | |
| DIMENSIONS: mm [INCHES] | | CHK MACE SAMUEL 06JAN11 | | |
| TOLERANCES UNLESS OTHERWISE SPECIFIED: | | APVD MACE SAMUEL 06JAN11 | NAME | |
| 0 PLC ± 0.50 | 1 PLC ± 0.30 | PRODUCT SPEC | 108-2418 2 | |
| 2 PLC ± 0.20 | 3 PLC ± 0.10 | APPLICATION SPEC | 114-13315 | |
| 4 PLC ± - | ANGLES ± 3° | WEIGHT 0 | SIZE A2 | CAGE CODE 00779 |
| MATERIAL - | FINISH - | CUSTOMER DRAWING | DRAWING NO C=2132230 | RESTRICTED TO - |
| | | | SCALE 1:1 | SHEET 1 OF 2 |
| | | | REV F2 | |

2132230

A

THIS DRAWING IS UNPUBLISHED. RELEASED FOR PUBLICATION
 © COPYRIGHT - By - ALL RIGHTS RESERVED.

| REVISIONS | | | | | |
|-----------|-----|-------------|------|-----|------|
| P | LTR | DESCRIPTION | DATE | DWN | APVD |
| - | - | SEE SHEET 1 | - | - | - |

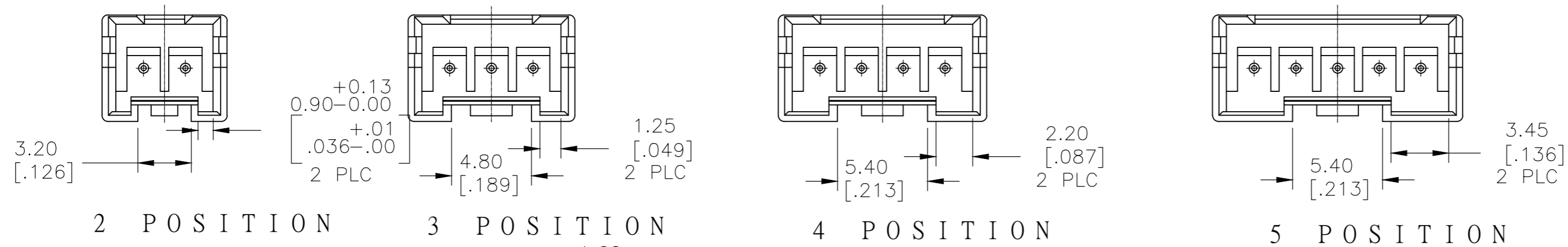

2 POSITION 3 POSITION 4 POSITION 5 POSITION

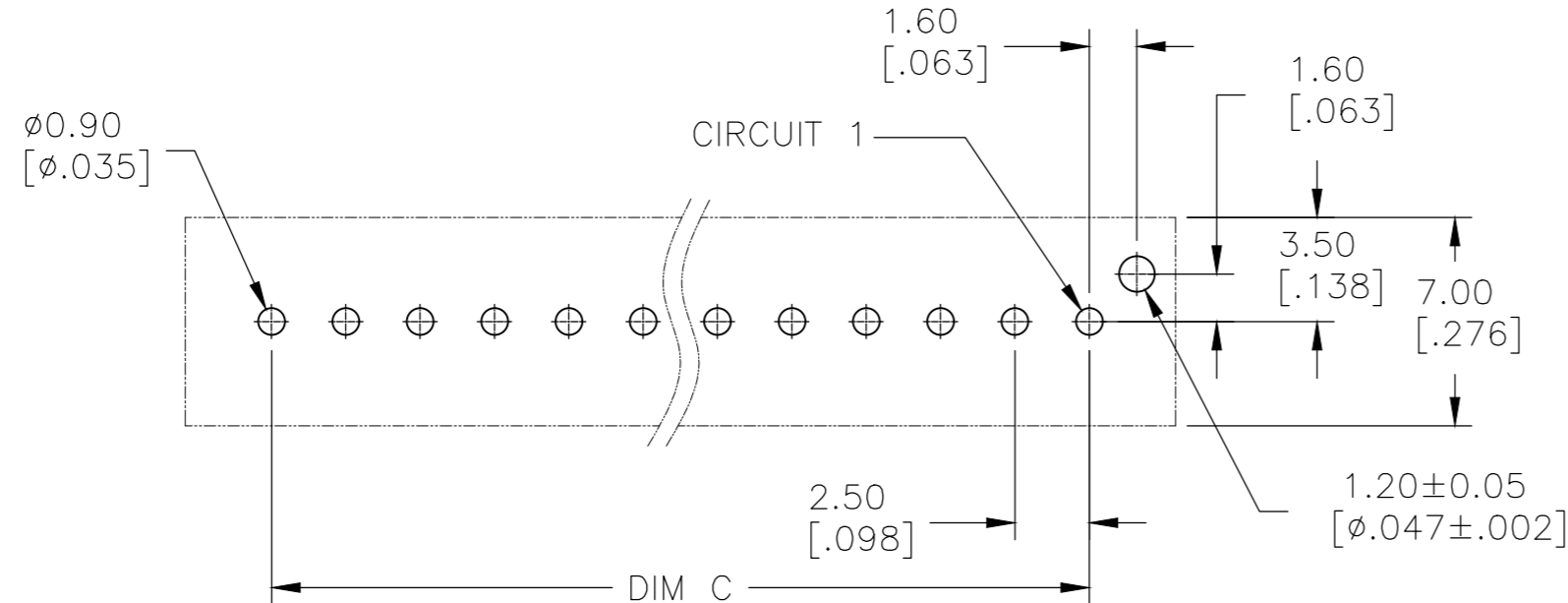

RECOMMENDED PCB LAYOUT

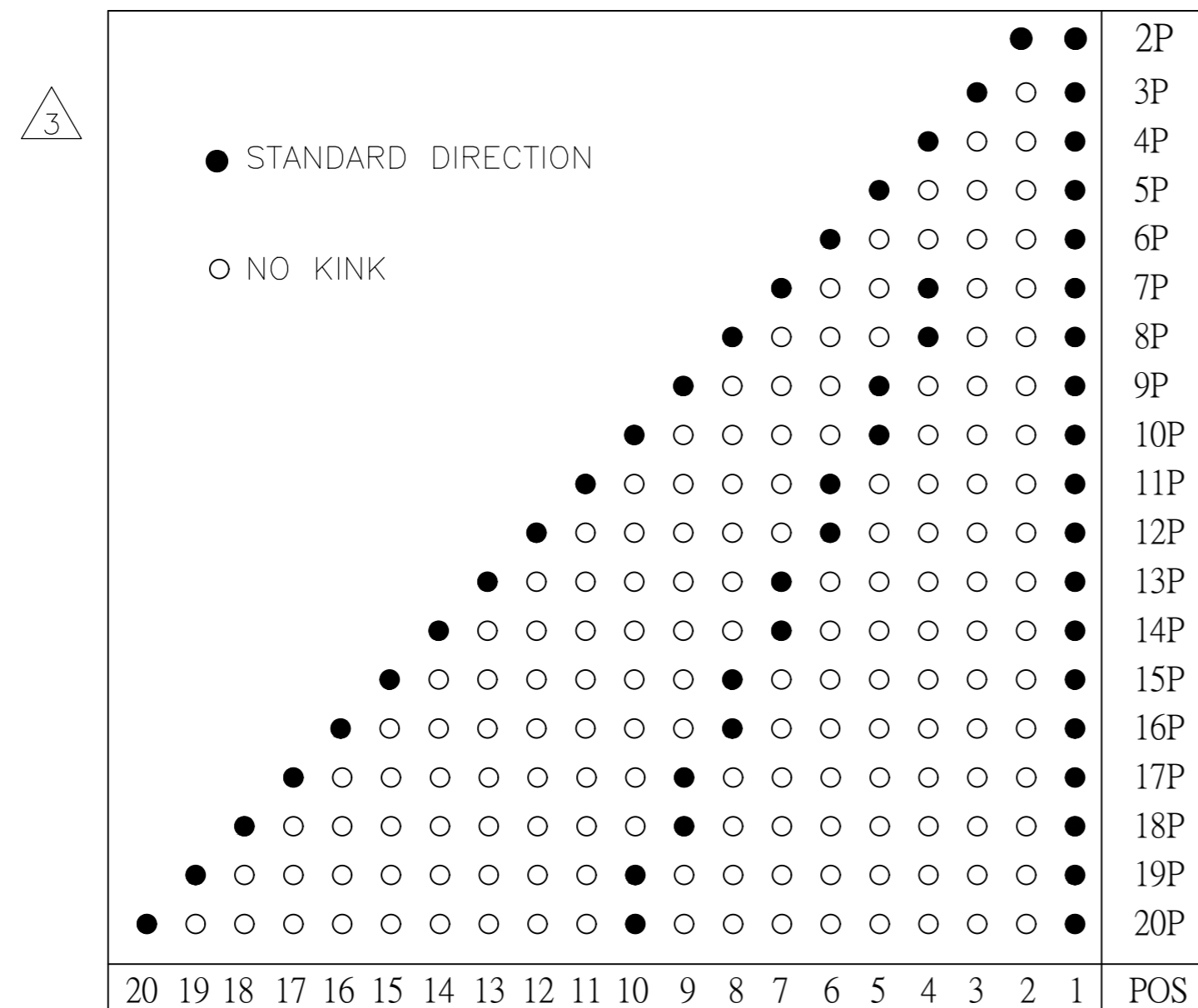

| | | | | |
|--------------|---------------|--------------|-----|-------------|
| 47.5 [1.870] | 50.83 [2.001] | 52.5 [2.067] | 20 | 2-2132230-0 |
| 45.0 [1.772] | 48.33 [1.903] | 50.0 [1.968] | 19 | 1-2132230-9 |
| 42.5 [1.673] | 45.83 [1.804] | 47.5 [1.870] | 18 | 1-2132230-8 |
| 40.0 [1.575] | 43.33 [1.706] | 45.0 [1.772] | 17 | 1-2132230-7 |
| 37.5 [1.476] | 40.83 [1.607] | 42.5 [1.673] | 16 | 1-2132230-6 |
| 35.0 [1.378] | 38.33 [1.510] | 40.0 [1.575] | 15 | 1-2132230-5 |
| 32.5 [1.280] | 35.83 [1.411] | 37.5 [1.476] | 14 | 1-2132230-4 |
| 30.0 [1.181] | 33.33 [1.312] | 35.0 [1.378] | 13 | 1-2132230-3 |
| 27.5 [1.083] | 30.83 [.214] | 32.5 [1.280] | 12 | 1-2132230-2 |
| 25.0 [.984] | 28.33 [.115] | 30.0 [1.181] | 11 | 1-2132230-1 |
| 22.5 [.886] | 25.83 [.167] | 27.5 [1.083] | 10 | 1-2132230-0 |
| 20.0 [.787] | 23.33 [.919] | 25.0 [.984] | 9 | 2132230-9 |
| 17.5 [.689] | 20.83 [.820] | 22.5 [.886] | 8 | 2132230-8 |
| 15.0 [.591] | 18.33 [.722] | 20.0 [.787] | 7 | 2132230-7 |
| 12.5 [.492] | 15.83 [.623] | 17.5 [.689] | 6 | 2132230-6 |
| 10.0 [.394] | 13.33 [.525] | 15.0 [.591] | 5 | 2132230-5 |
| 7.5 [.295] | 10.83 [.426] | 12.5 [.492] | 4 | 2132230-4 |
| 5.0 [.197] | 8.33 [.328] | 10.0 [.394] | 3 | 2132230-3 |
| 2.5 [.098] | 5.83 [.229] | 7.5 [.295] | 2 | 2132230-2 |
| DIM C | DIM B | DIM A | POS | PART NO |

| | | | | |
|--|--|--------------------------------|---|--------------------|
| THIS DRAWING IS A CONTROLLED DOCUMENT. | | DWN RAGHAVENDRA 06JAN11 | TE Connectivity | |
| DIMENSIONS: mm [INCHES] | | CHK MACE SAMUEL 06JAN11 | NAME HEADER ASSEMBLY, VERTICAL, ECONOMY POWER, 2.5mm CENTERLINE | |
| TOLERANCES UNLESS OTHERWISE SPECIFIED: | | APVD MACE SAMUEL 06JAN11 | DRAWING NO 114-13315 | |
| 0 PLC ± 0.50 | | PRODUCT SPEC 108-2418 | SIZE A2 | CAGE CODE 00779 |
| 1 PLC ± 0.30 | | APPLICATION SPEC 114-13315 | DRAWING NO C=2132230 | RESTRICTED TO - |
| 2 PLC ± 0.20 | | WEIGHT - | SCALE 1:1 | SHEET 2 OF 2 |
| 3 PLC ± 0.10 | | CUSTOMER DRAWING | REV F1 | |
| 4 PLC ± . | | | | |
| ANGLES ± 3° | | | | |
| FINISH - | | | | |

Mouser Electronics

Authorized Distributor

Click to View Pricing, Inventory, Delivery & Lifecycle Information:

[TE Connectivity:](#)

[2132230-7](#)