

KDC5512EVAL, KDC5512HEVAL, KDC5512-50EVAL, KDC5514EVAL Schematics

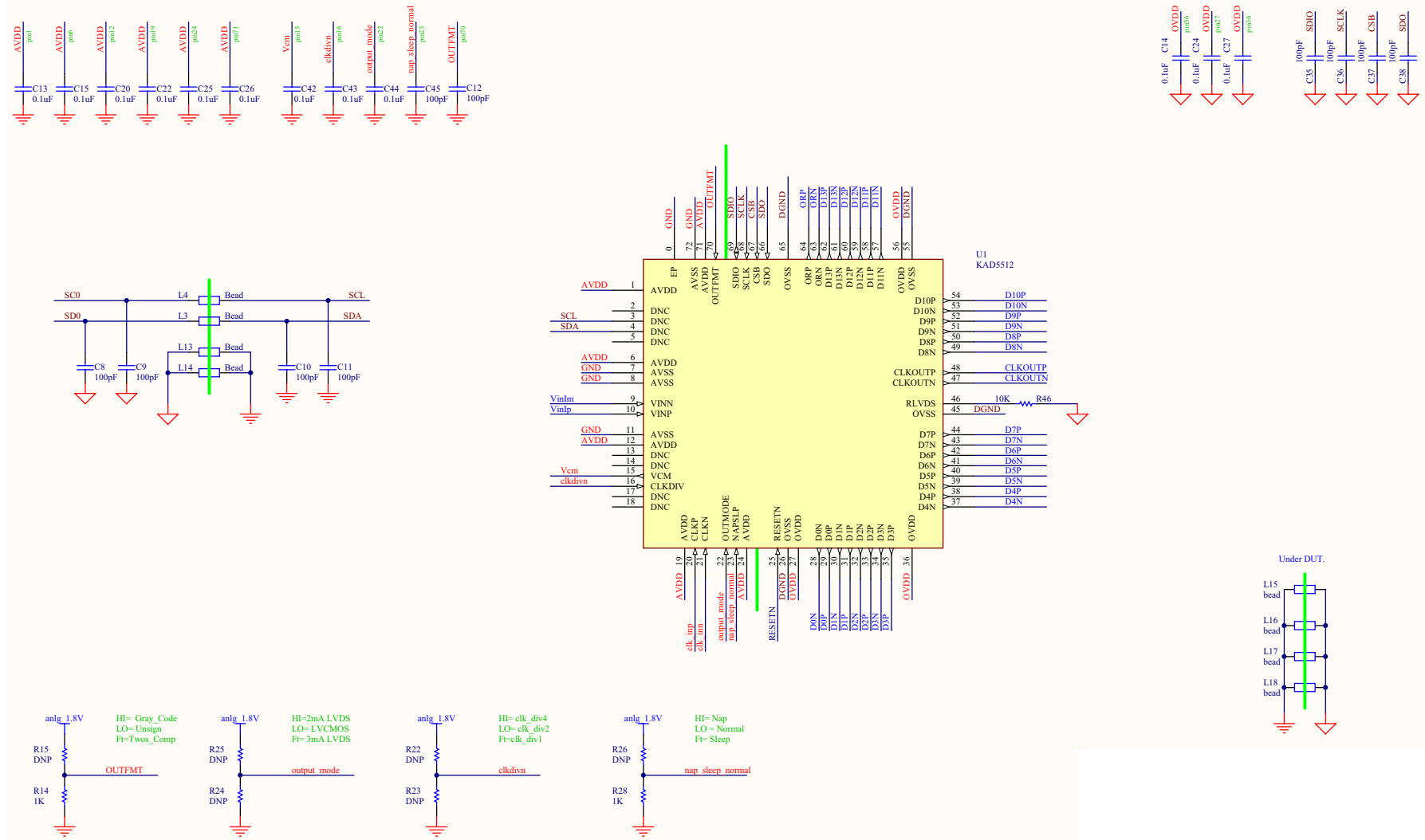

FIGURE 1. ADC, MODE PINS AND POWER SUPPLY BYPASS

KDC5512EVAL, KDC5512HEVAL, KDC5512-50EVAL, KDC5514EVAL Schematics (Continued)

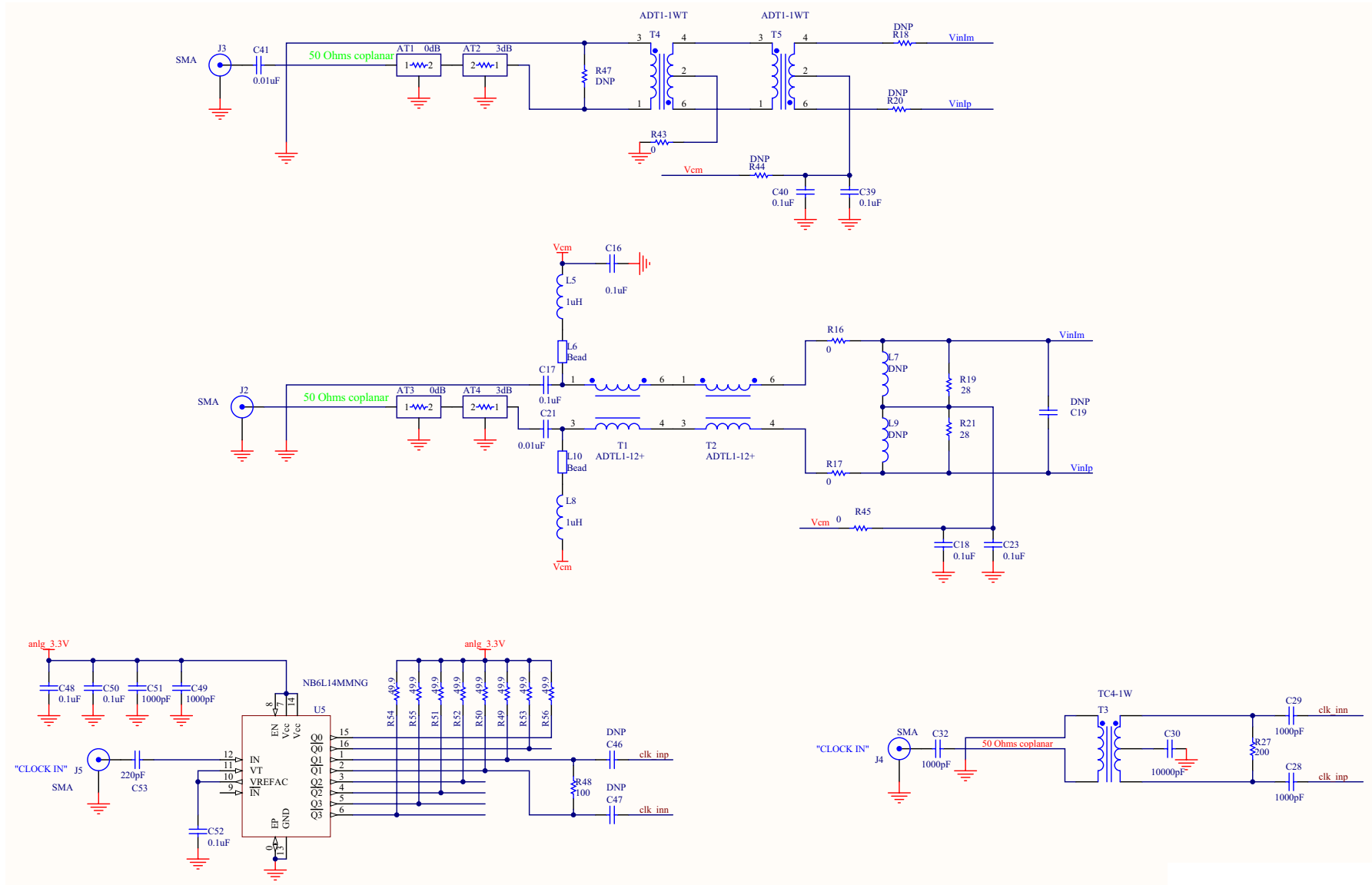

FIGURE 2. CLOCK AND ANALOG INPUTS

KDC5512EVAL, KDC5512HEVAL, KDC5512-50EVAL, KDC5514EVAL Schematics (Continued)

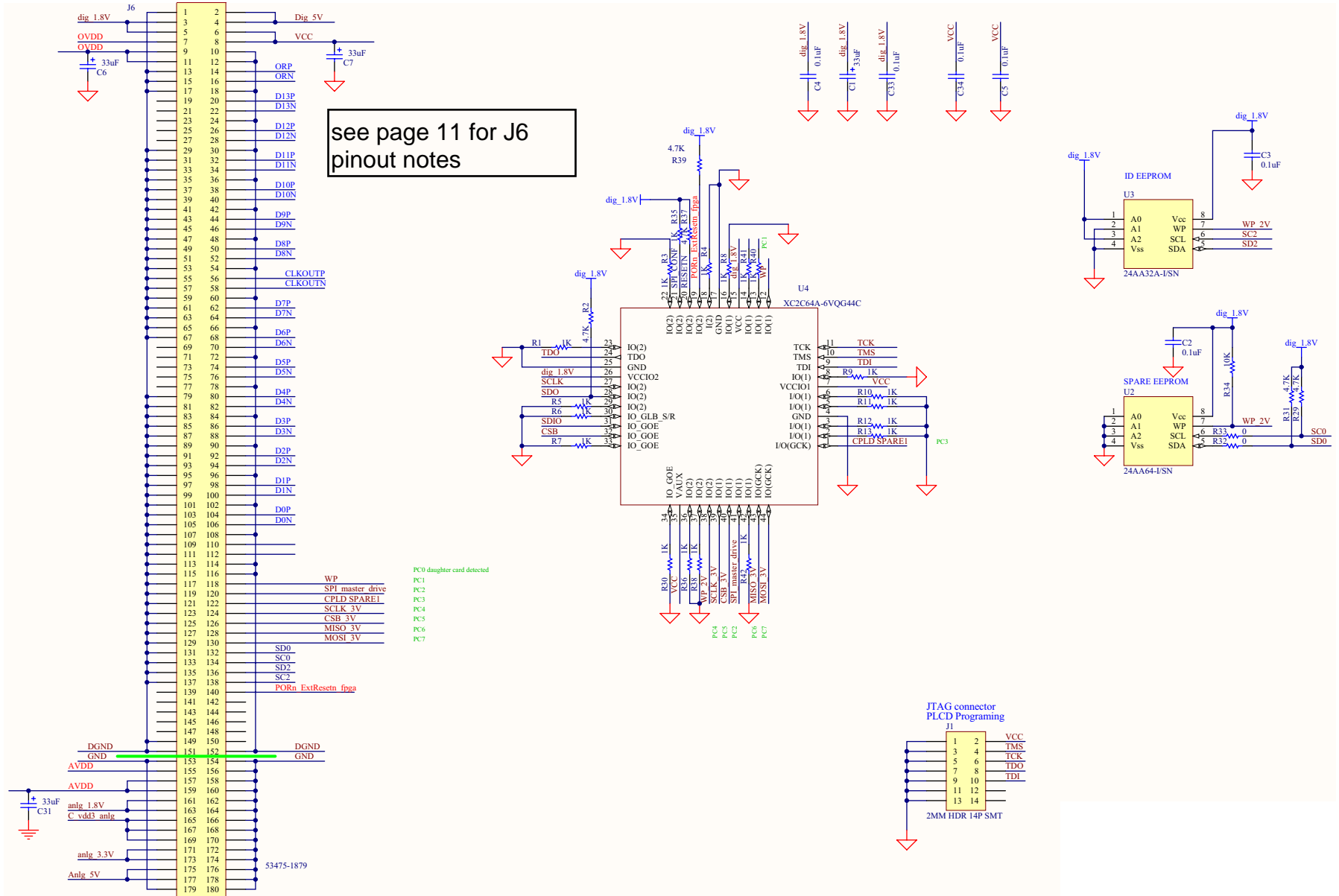

FIGURE 3. INPUT/OUTPUT MEZZANINE CONNECTOR

KDC5512EVAL, KDC5512HEVAL, KDC5512-50EVAL, KDC5514EVAL REV B Layers

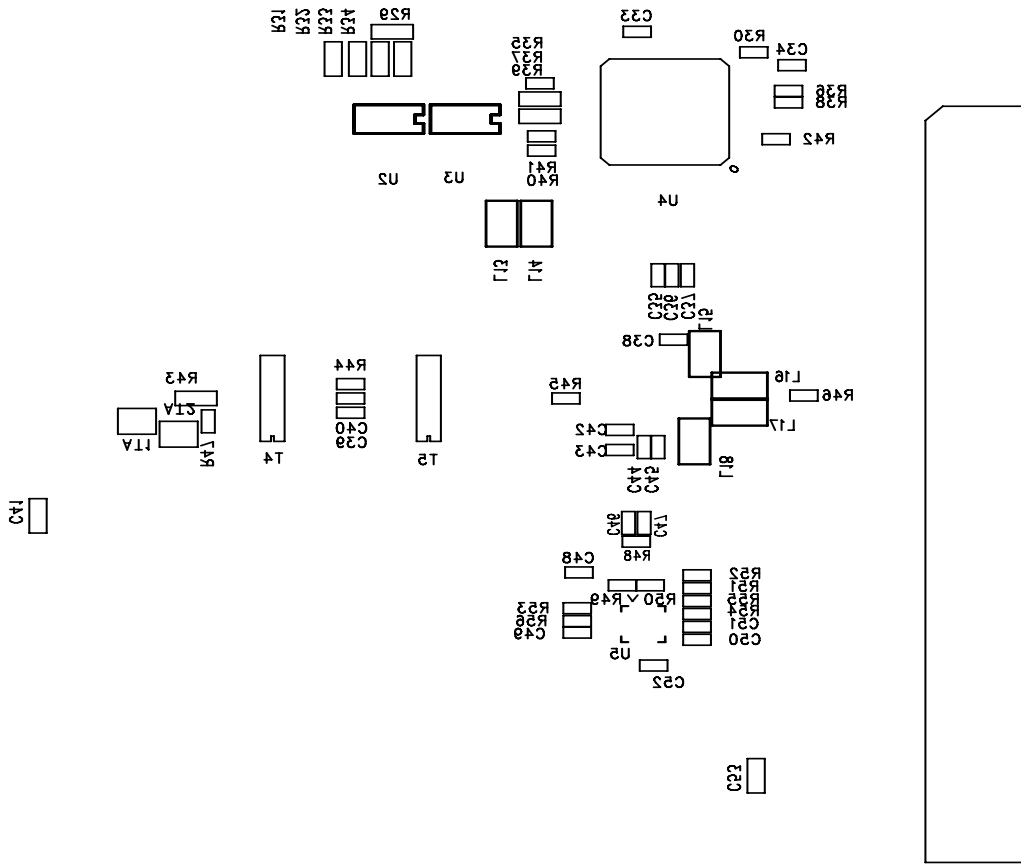

FIGURE 4. LAYER - SECONDARY SIDE SILKSCREEN

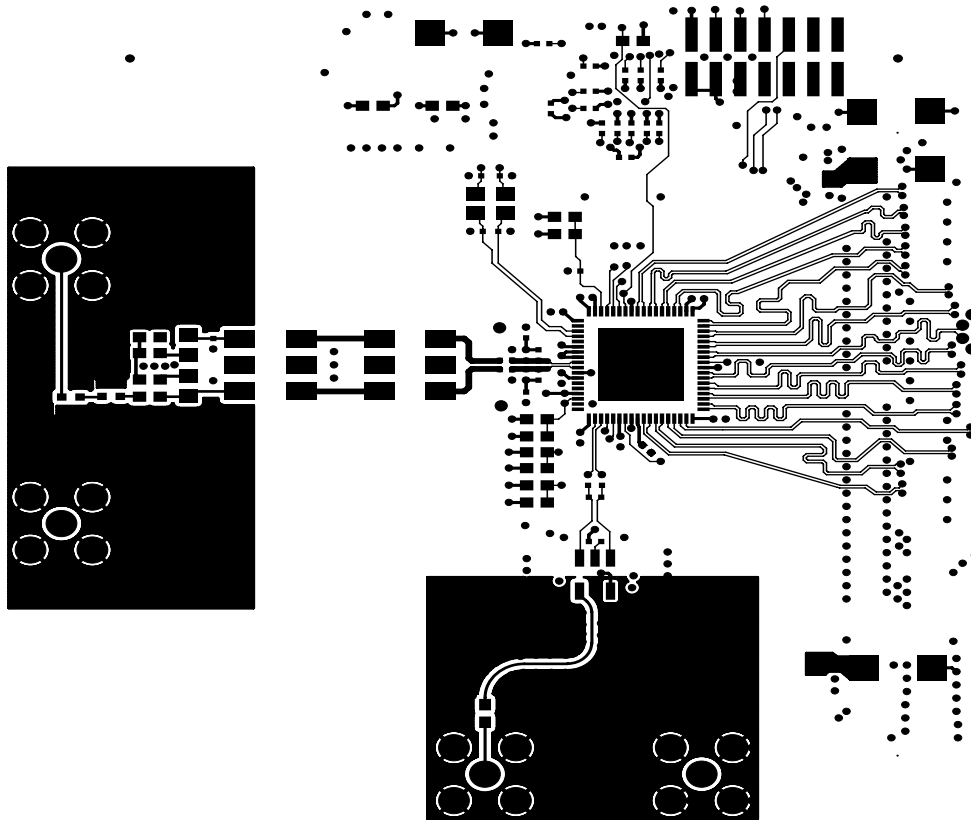

FIGURE 5. LAYER 1 - PRIMARY SIDE

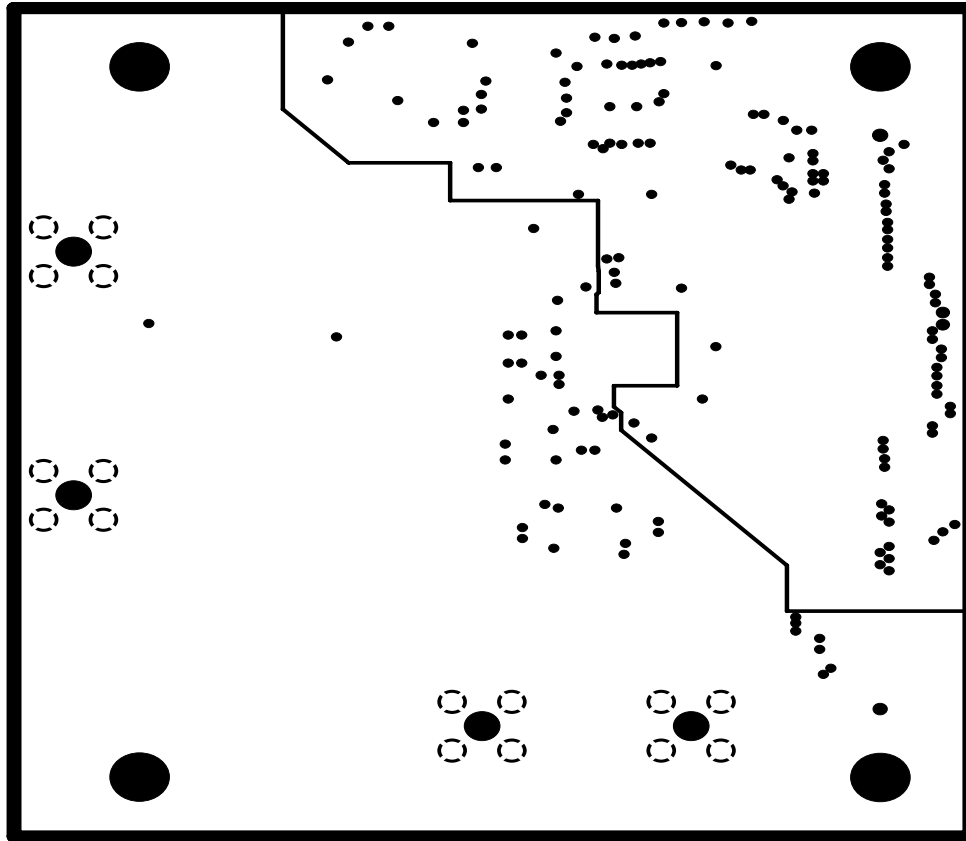

FIGURE 6. LAYER 2 - GND PLANE 1

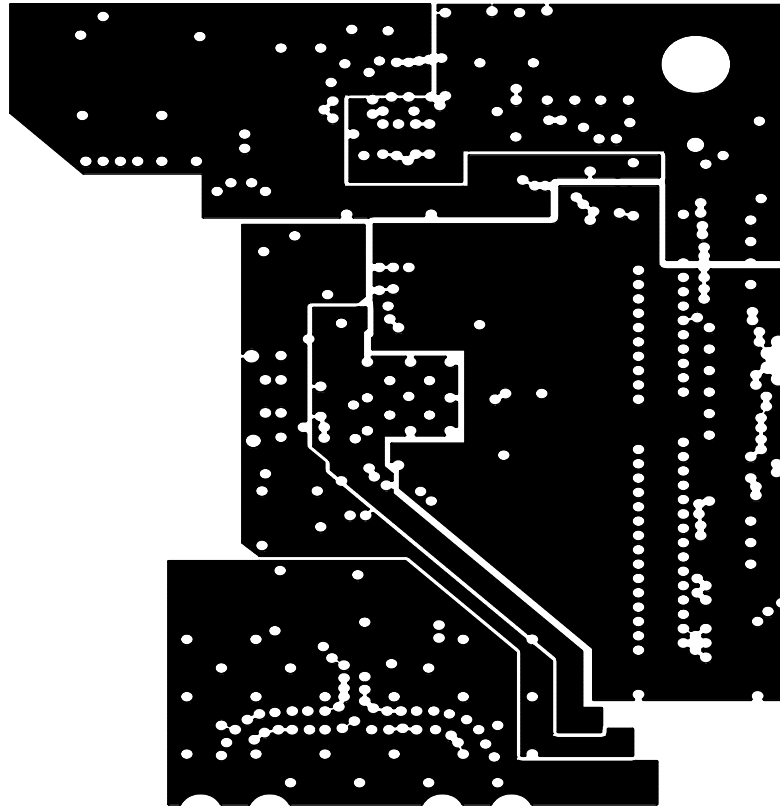

FIGURE 7. LAYER 3 - PWR PLANE

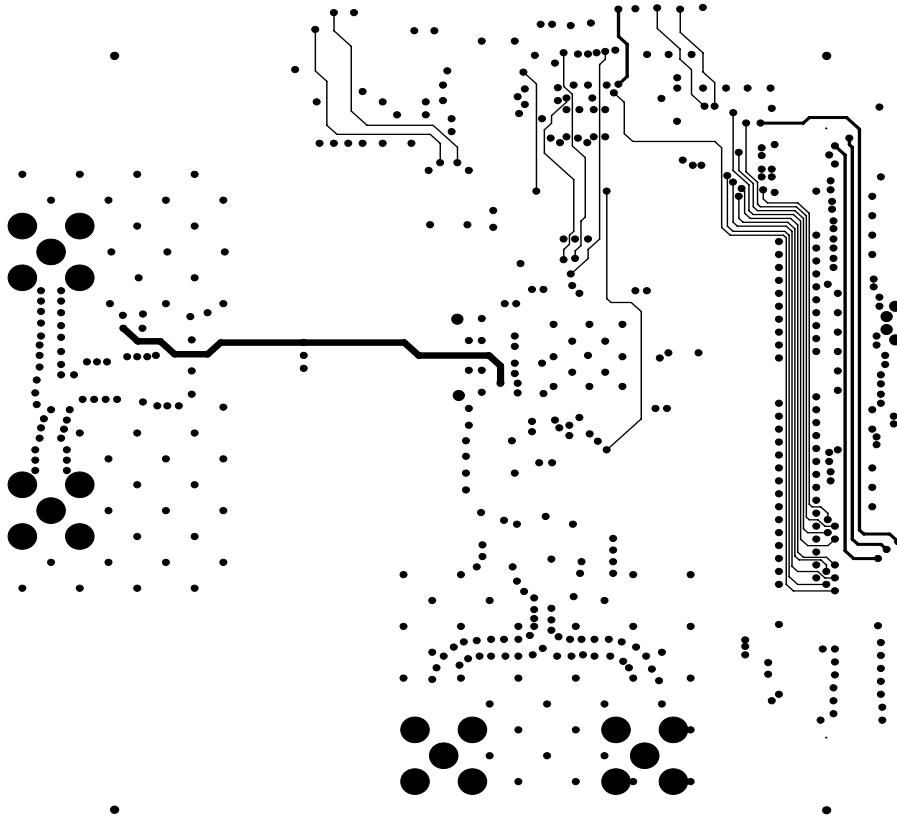

FIGURE 8. LAYER 4 - INTERNAL SIGNAL

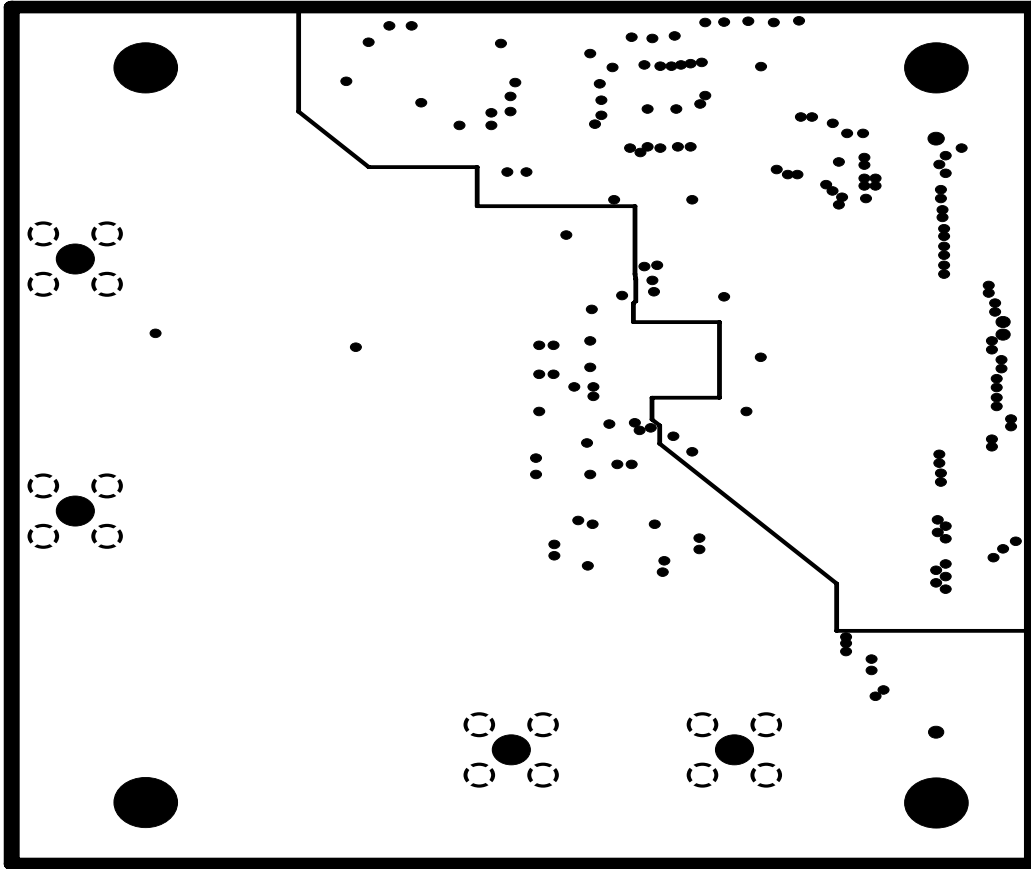

FIGURE 9. LAYER 5 - GND PLANE 2

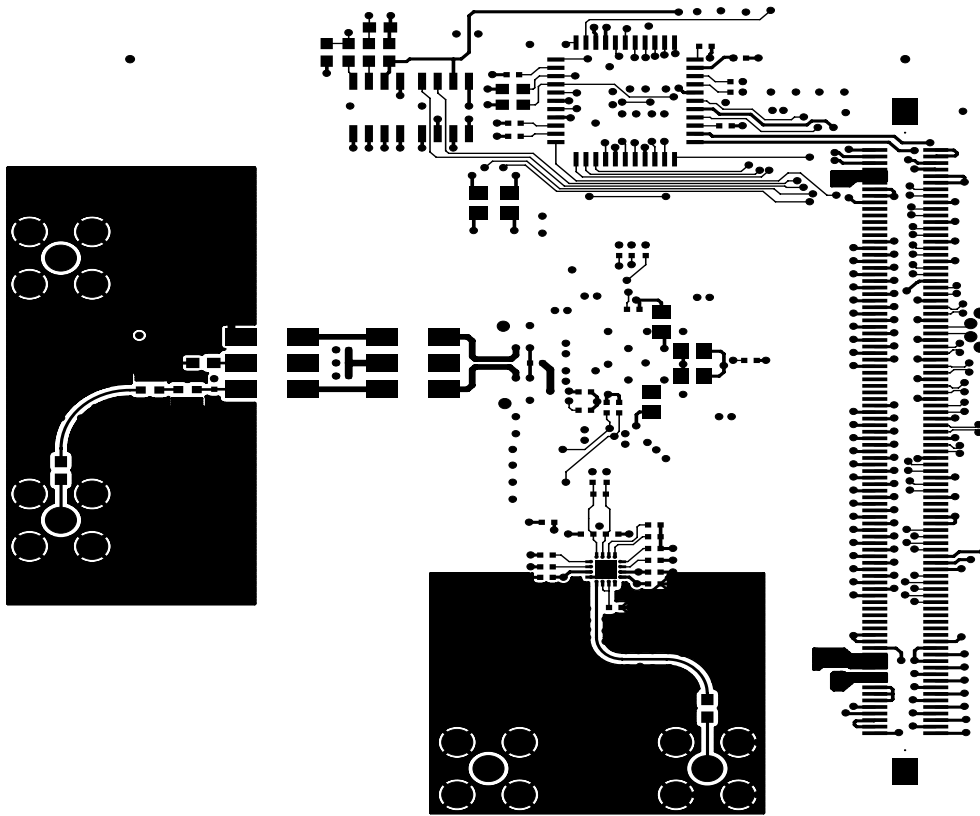

FIGURE 10. LAYER 6 - SECONDARY SIDE

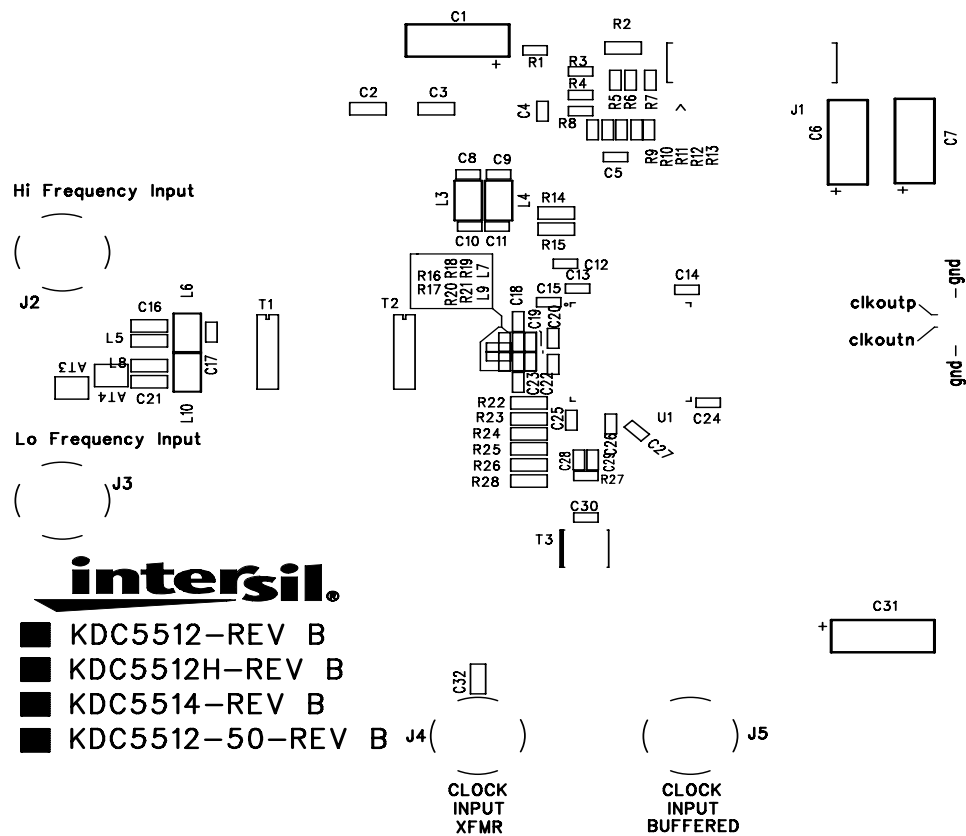

FIGURE 11. LAYER - PRIMARY SIDE SILKSCREEN

J6 pinout is shown for 14bit device. ADC Output Data pins are MSB justified at J6. Pins 20, 22 at J6 are the MSB for 14, 12, 10 and 8 bit devices (MSB = D13, D11, D9, and D7 for 14, 12, 10, and 8 bit devices respectively). J6 pins 26, 28 are MSB -1. Contact factory for additional information if needed.

Intersil Corporation reserves the right to make changes in circuit design, software and/or specifications at any time without notice. Accordingly, the reader is cautioned to verify that the Application Note or Technical Brief is current before proceeding.

Mouser Electronics

Authorized Distributor

Click to View Pricing, Inventory, Delivery & Lifecycle Information:

[Renesas Electronics:](#)

[KDC5512HEVAL](#) [KDC5512HEVALZ](#)