

THIS DRAWING IS UNPUBLISHED. RELEASED FOR PUBLICATION 20
 © COPYRIGHT 20 BY - ALL RIGHTS RESERVED.

LOC	DIST	REVISIONS			
P	LTR	DESCRIPTION	DATE	DWN	APVD
DY	-	E3 REVISED PER ECR-13-003471	25FEB13	RW	SY

- NOTES:
- 1 MATERIAL:
HOUSING: GLASS FILLED PBT, NATURAL COLOR (WHITE)
CONTACT: PHOSPHOR BRONZE
 - 2 FINISH: MATTE TIN OVER NICKEL UNDERPLATE
 - 3 KINK CONTACTS LOCATION:
8P & BELOW: ALL POSITIONS
9P & ABOVE: 4 CONTACTS (2 PAIRS) EACH END
 - 4. PACKAGING: TUBE

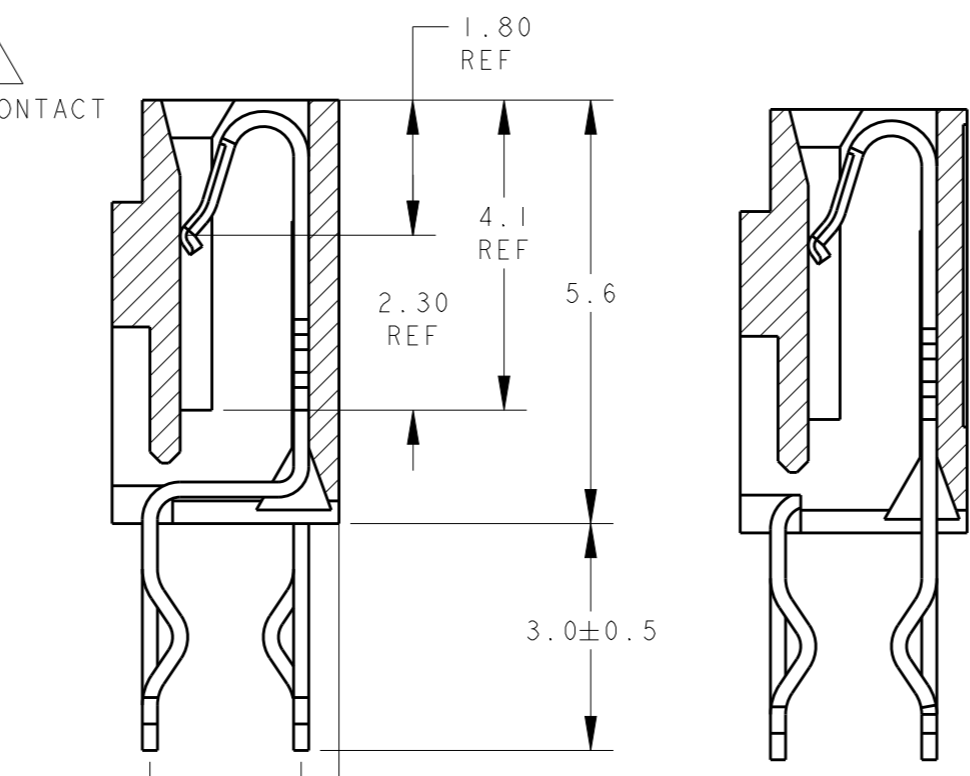
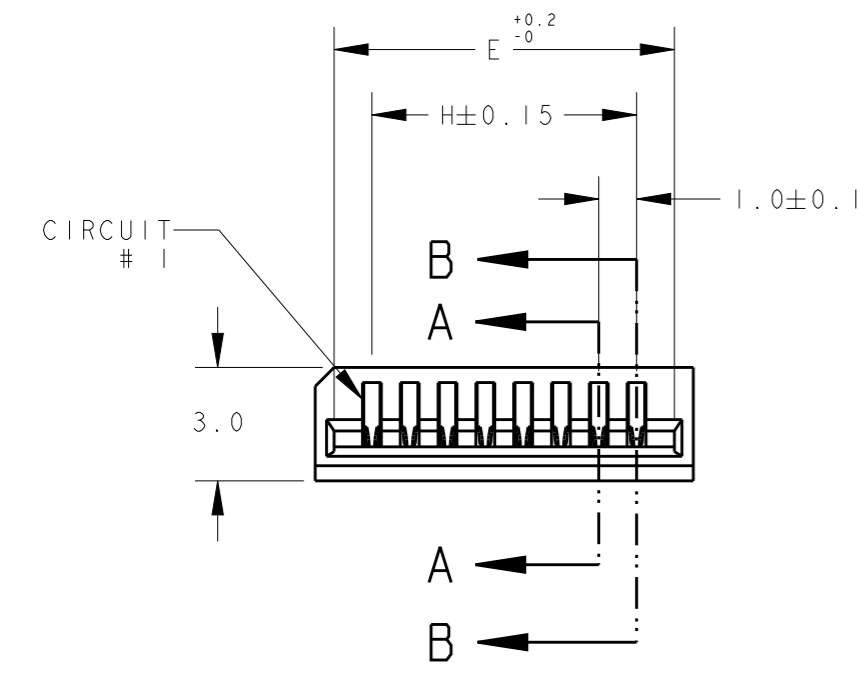
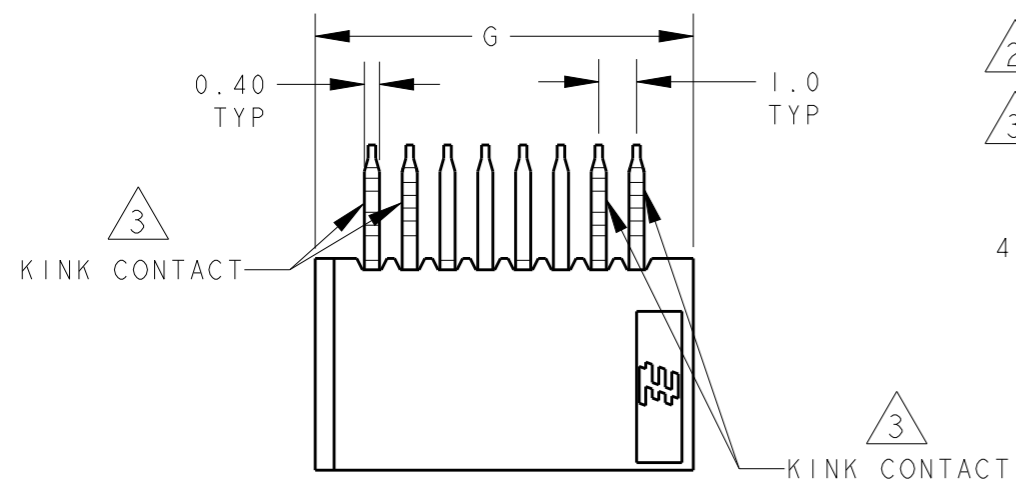

29.00	32.00	31.00	31.00	30	3-84984-0
28.00	31.00	30.00	30.00	29	2- -9
27.00	30.00	29.00	29.00	28	2- -8
26.00	29.00	28.00	28.00	27	2- -7
25.00	28.00	27.00	27.00	26	2- -6
24.00	27.00	26.00	26.00	25	2- -5
23.00	26.00	25.00	25.00	24	2- -4
22.00	25.00	24.00	24.00	23	2- -3
21.00	24.00	23.00	23.00	22	2- -2
20.00	23.00	22.00	22.00	21	2- -1
19.00	22.00	21.00	21.00	20	2-84984-0
18.00	21.00	20.00	20.00	19	1- -9
17.00	20.00	19.00	19.00	18	1- -8
16.00	19.00	18.00	18.00	17	1- -7
15.00	18.00	17.00	17.00	16	1- -6
14.00	17.00	16.00	16.00	15	1- -5
13.00	16.00	15.00	15.00	14	1- -4
12.00	15.00	14.00	14.00	13	1- -3
11.00	14.00	13.00	13.00	12	1- -2
10.00	13.00	12.00	12.00	11	1- -1
9.00	12.00	11.00	11.00	10	1-84984-0
8.00	11.00	10.00	10.00	9	-9
7.00	10.00	9.00	9.00	8	-8
6.00	9.00	8.00	8.00	7	-7
5.00	8.00	7.00	7.00	6	-6
4.00	7.00	6.00	6.00	5	-5
3.00	6.00	5.00	5.00	4	84984-4
H	G	F	E	POS.	PART NO.

THIS DRAWING IS A CONTROLLED DOCUMENT.		DWN WYLEE 15JUN04	STE TE Connectivity
DIMENSIONS: mm		CHK LP TAN 22NOV2011	
TOLERANCES UNLESS OTHERWISE SPECIFIED:		APVD SF LEONG 22NOV2011	
0 PLC ±0.30 1 PLC ±0.30 2 PLC ±0.30 3 PLC ± 4 PLC ± ANGLES ±3°		PRODUCT SPEC 108-51058	
MATERIAL 1	FINISH 2	APPLICATION SPEC -	NAME ASSY, 1.00mm FFC CONN DIP, V
Customer Drawing		WEIGHT -	SIZE A300779 CAGE CODE G-84984
		SCALE 5:1	RESTRICTED TO -
		SHEET 1 OF 2	REV E3

THIS DRAWING IS UNPUBLISHED. RELEASED FOR PUBLICATION 20
 © COPYRIGHT 20 BY - ALL RIGHTS RESERVED.

LOC	DIST	REVISIONS			
P	LTR	DESCRIPTION	DATE	DWN	APVD
DY	-	SEE SHEET 1			

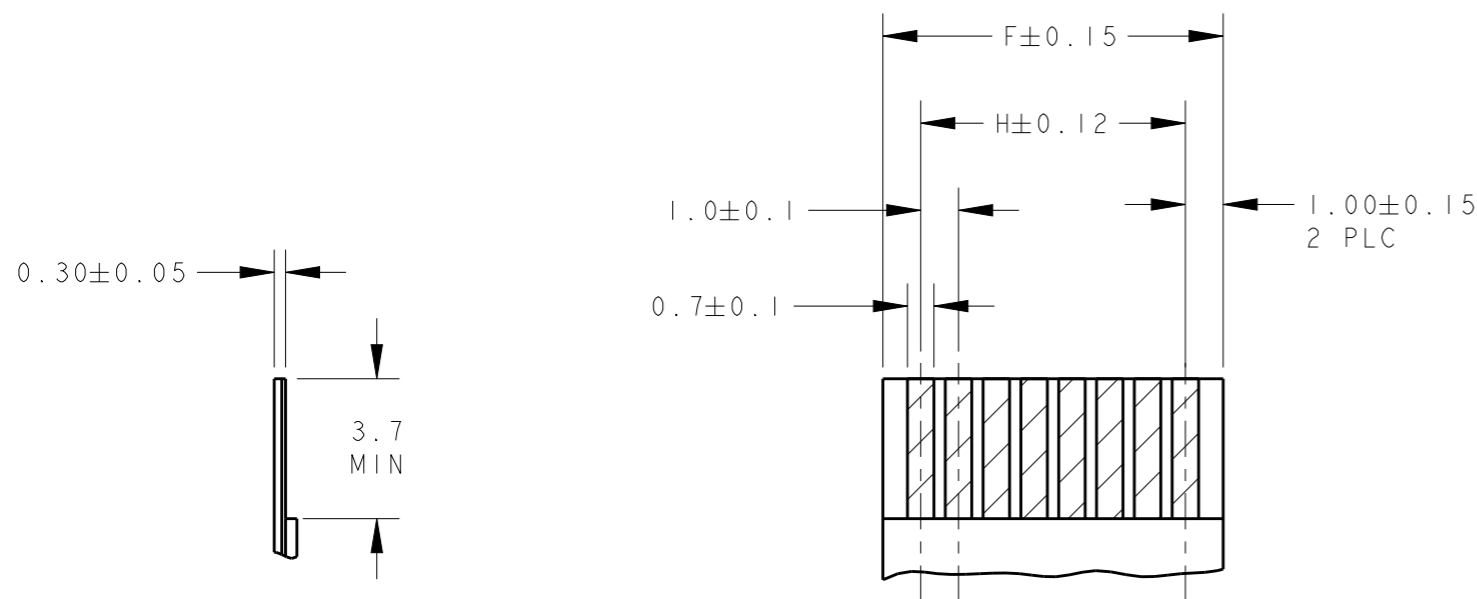

RECOMMENDED FFC/FPC

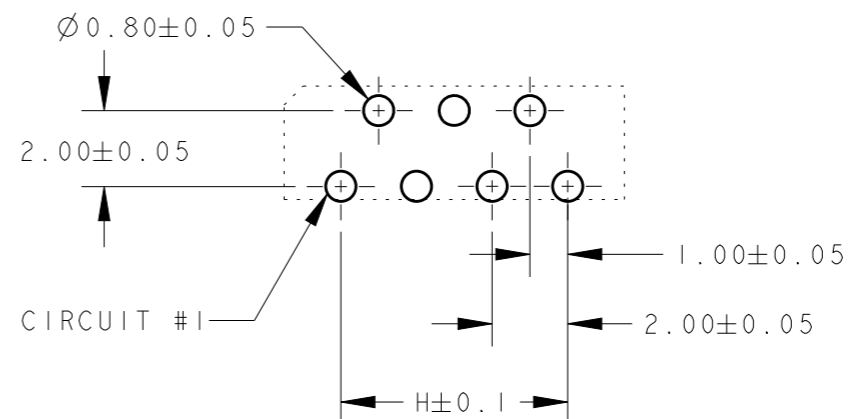

RECOMMENDED PCB LAYOUT (THK= 1.6±0.1)
 (FOR ODD POSITION CONNECTORS)
 NON-ACCUMULATIVE TOLERANCE

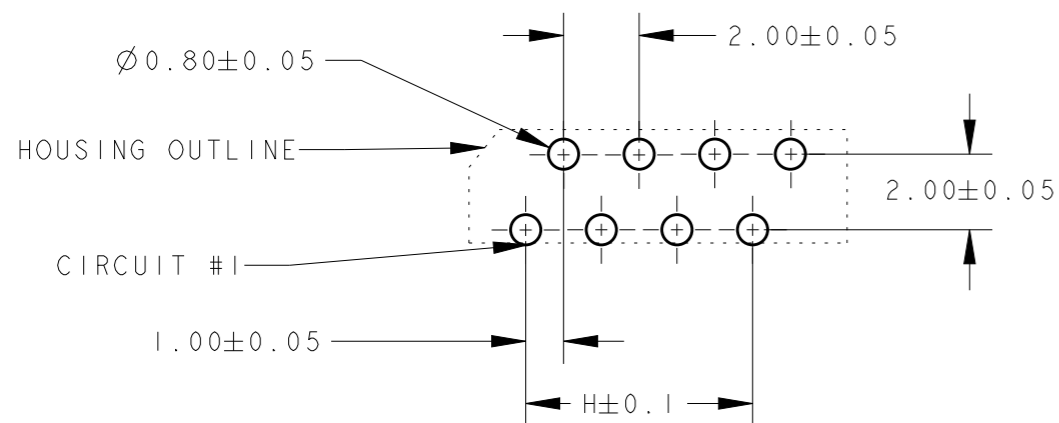

RECOMMENDED PCB LAYOUT (THK= 1.6±0.1)
 (FOR EVEN POSITION CONNECTORS)
 NON-ACCUMULATIVE TOLERANCE

THIS DRAWING IS A CONTROLLED DOCUMENT.		DWN WYLEE	15JUN04	TE Connectivity	
DIMENSIONS: mm		CHK LP TAN	22NOV2011		
TOLERANCES UNLESS OTHERWISE SPECIFIED:		APVD SEIFONG	22NOV2011	NAME ASSY, 1.00mm FFC CONN DIP, V	
0 PLC ±0.30 1 PLC ±0.30 2 PLC ±0.30 3 PLC ± 4 PLC ± ANGLES ±3°		PRODUCT SPEC 108-51058		RESTRICTED TO	
MATERIAL 1		FINISH 2		SIZE A300779	CAGE CODE C-84984
		WEIGHT -		DRAWING NO	
		Customer Drawing		SCALE 5:1	SHEET 2 OF 2
				REV E3	

Mouser Electronics

Authorized Distributor

Click to View Pricing, Inventory, Delivery & Lifecycle Information:

[TE Connectivity:](#)

[84984-4](#)