

MATERIAL NUMBER	OLD PART NUMBER	FINISHED LENGTH
1300062363	104001K12M020	2M +89mm -0 [6' 7" +3.5 IN -0]
1300069046	104001K12M050	5M +165mm -0 [16' 5" +6.5IN -0]
1300069047	104001K12M100	10M +318mm -0 [32' 10" +12.5IN -0]
1300069048	104001K12M200	20M +622mm -0 [65' 7" +24.5IN -0]
1300069049	104001K12M300	30M +622mm -0 [98' 5" +24.5IN -0]

104001K12M050

cable type
16AWG-4
FLEX TPE

cable length
050----5 Meters
100----10 Meters

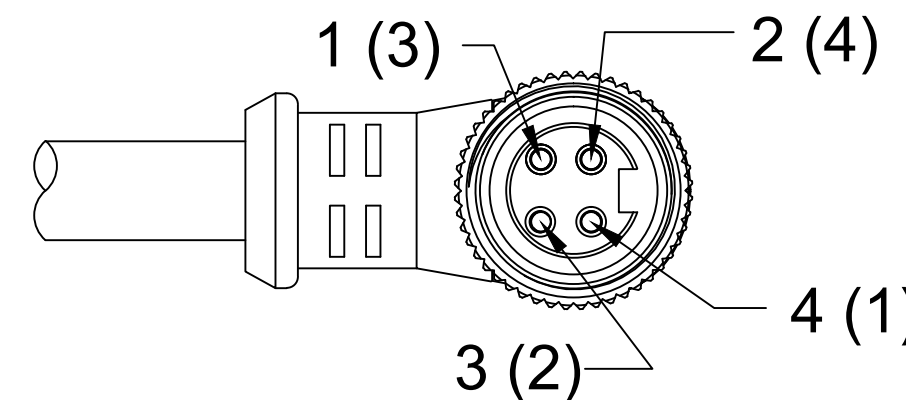
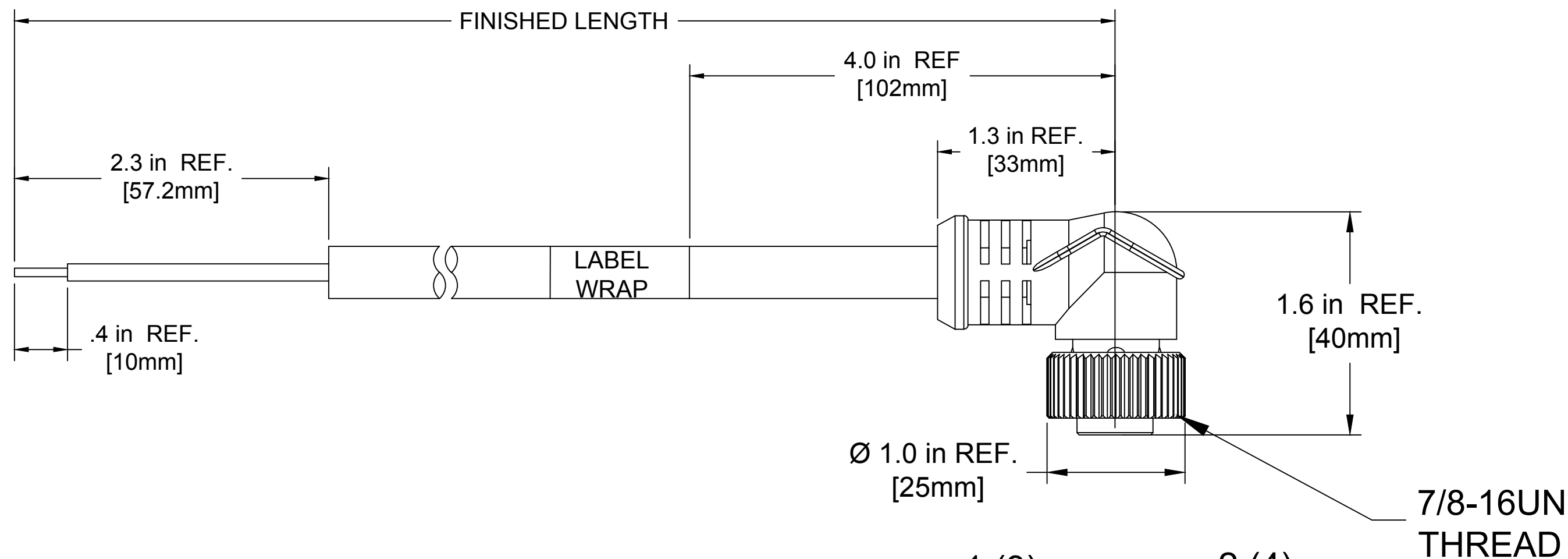

FEMALE FACE VIEW

CENELEC EN 50 044 PINOUT SHOWN
(SAE-J-1738A SHOWN IN PARENTHESIS)

BLACK	4 (1)
BLUE	3 (2)
BROWN	1 (3)
WHITE	2 (4)

SPECIFICATION DATA

COMPONENT	MATERIAL	FINISH
COUPLING NUT	ZINC DIE CAST	BLACK E-COATED
LABEL	VINYL	BLACK/YELLOW
CONTACT	COPPER ALLOY	GOLD PLATED
INSERT	TPE	YELLOW
OVERMOLD	TPE	YELLOW
CABLE 16AWG	TC ER FLEX TPE	YELLOW

VOLTAGE RATING:	600V
AMPERAGE RATING:	10A
PROTECTION CLASS:	IP 67
OPERATING TEMPERATURE:	-20°C TO +105°C
UL CERTIFICATION:	FILE NO. E152210
CSA CERTIFICATIONS:	FILE NO. LR6837

REVD NOTES & LENGTH TOLS. ADD CENELEC EC NO.: IPG2014-1158 DRWN: RSTONE 12/20/13 CH'KD: TW APPR: BWOODMAN2013/11/12	QUALITY SYMBOL	GENERAL TOLERANCES (UNLESS SPECIFIED)	DIMENSION STYLE	SCALE	DESIGN UNITS	THIRD ANGLE PROJECTION
	▽=0	mm INCH	IN / MM	NTS	INCH	
	∇=0	4 PLACES ±--- ±---	DRAWN BY DATE	GGUSTAFS 2013/10/04	TITLE	
		3 PLACES ±--- ±.005	CHECKED BY DATE	TWOLDEGE 2013/11/15	MINI CHANGE 4 POLE FEMALE 90D 16/4 AWG TPE	
	2 PLACES ±0.13 ±.010	APPROVED BY DATE	BWOODMAN 2013/11/12	MOLEX INCORPORATED		
	1 PLACE ±0.25 ±.020	MATERIAL NO.	SEE CHART	DOCUMENT NO.	SHEET NO.	
	ANGULAR ±.5°	DRAFT WHERE APPLICABLE MUST REMAIN WITHIN DIMENSIONS		SD-130006-064		1 OF 1
		THIS DRAWING CONTAINS INFORMATION THAT IS PROPRIETARY TO MOLEX INCORPORATED AND SHOULD NOT BE USED WITHOUT WRITTEN PERMISSION				

Mouser Electronics

Authorized Distributor

Click to View Pricing, Inventory, Delivery & Lifecycle Information:

[Molex:](#)

[1300062363](#)