

SYMBOL DEFINITION		MISSING NUMBERS		DWG STATUS		ZONE		REVISION HISTORY		AUTH		DR		AP/VD	
DATE	STO	REV	N/P	CHG											
30JUL02	R	07	-	-				CLEARED REV COL & ALL PARTS - UPDATED PDM ATTRIBUTES	226419	JHN	FRG	TTP			
30JAO3	R	08	-	-				ALL PARTS - UPDATED PDM ATTRIBUTES	235188	CJP	CJP	CSD			
05FE03	R	09	-	-				REVISED NOTE SYMBOL 345 IN TOD	236543	LMB	LMB	SCH			
16JUL03	R	10	-	-				15392777: CORRECTED PLATING TYPE TO 102	243460	JMR	JMR	JMN			
22JUL03	R	11	-	-				ADDED DIM 2.75±0.1 FOR SPRING BACK	243779	RH	RH	SCH			
14APO4	R	12	-	-				15491972 - RELEASED	253968	TLD	TLD	MP			
24SE04	R	13	-	-				ALL PARTS ADDED STAMP DIE I.D.	259075	MDH	AUG	MKM			
09MY05	R	14	-	-				13528779 - RELEASED	267849	JTV	FKV	LJM			
16MY05	R	15	-	-				13528779 - MAT'L SPEC WAS M-3669	268220	JOA	JVM	LJM			
30MY05	R	16	-	-				15326004 - MATERIAL SPEC WAS M-3669	268590	BLG	JMV	LJM			
15AUG05	R	17	-	-				15326004 - UPDATED PDM ATTRIBUTES	271195	JBD	FRG	MJC			
30MY06	R	18	-	-				15366684, 15392777, 15401195 & 15491972-UPDATED PDM ATTRIBUTES	281105	TLD	TLD	MJC			

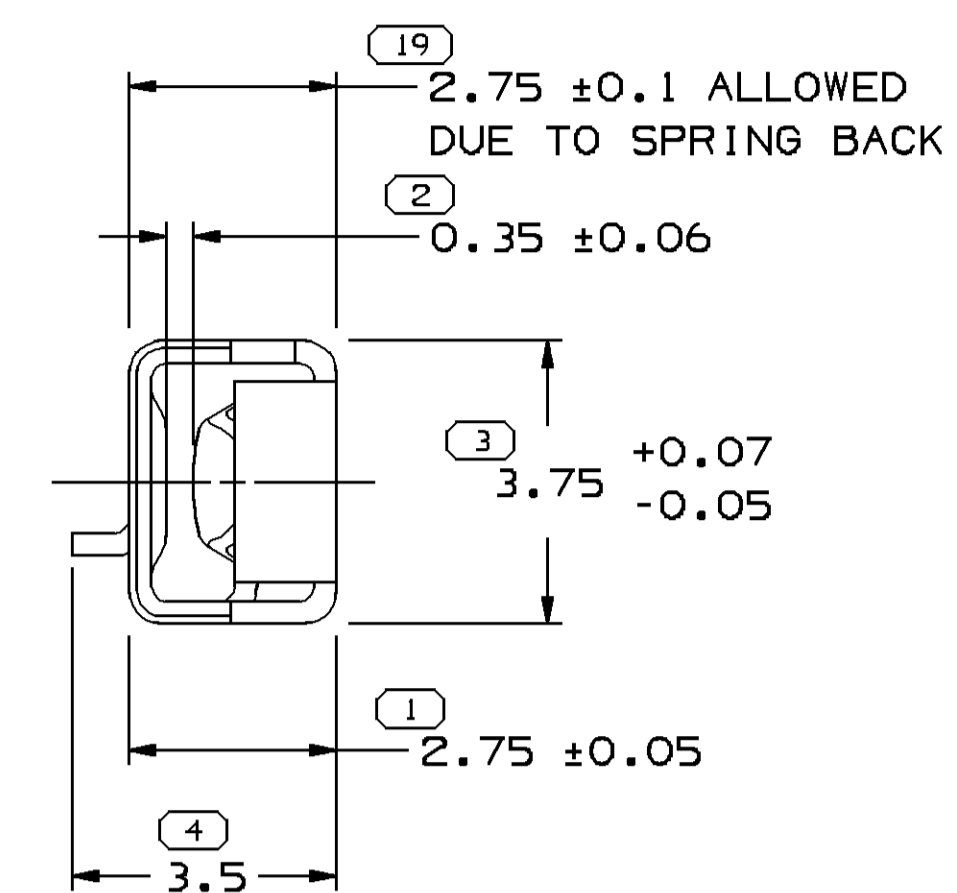

STAMP DIE I.D. "PXX" IN THIS AREA (0.6) CHARACTERS XX DESIGNATES DIE NUMBER, LOCATION IS APPROXIMATE.

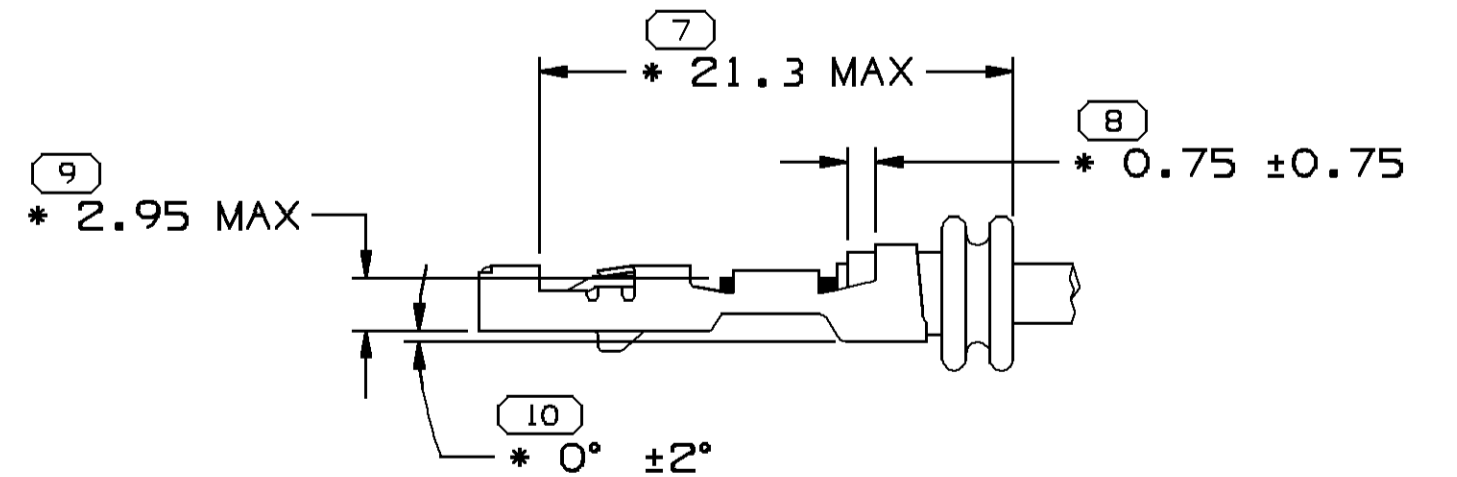
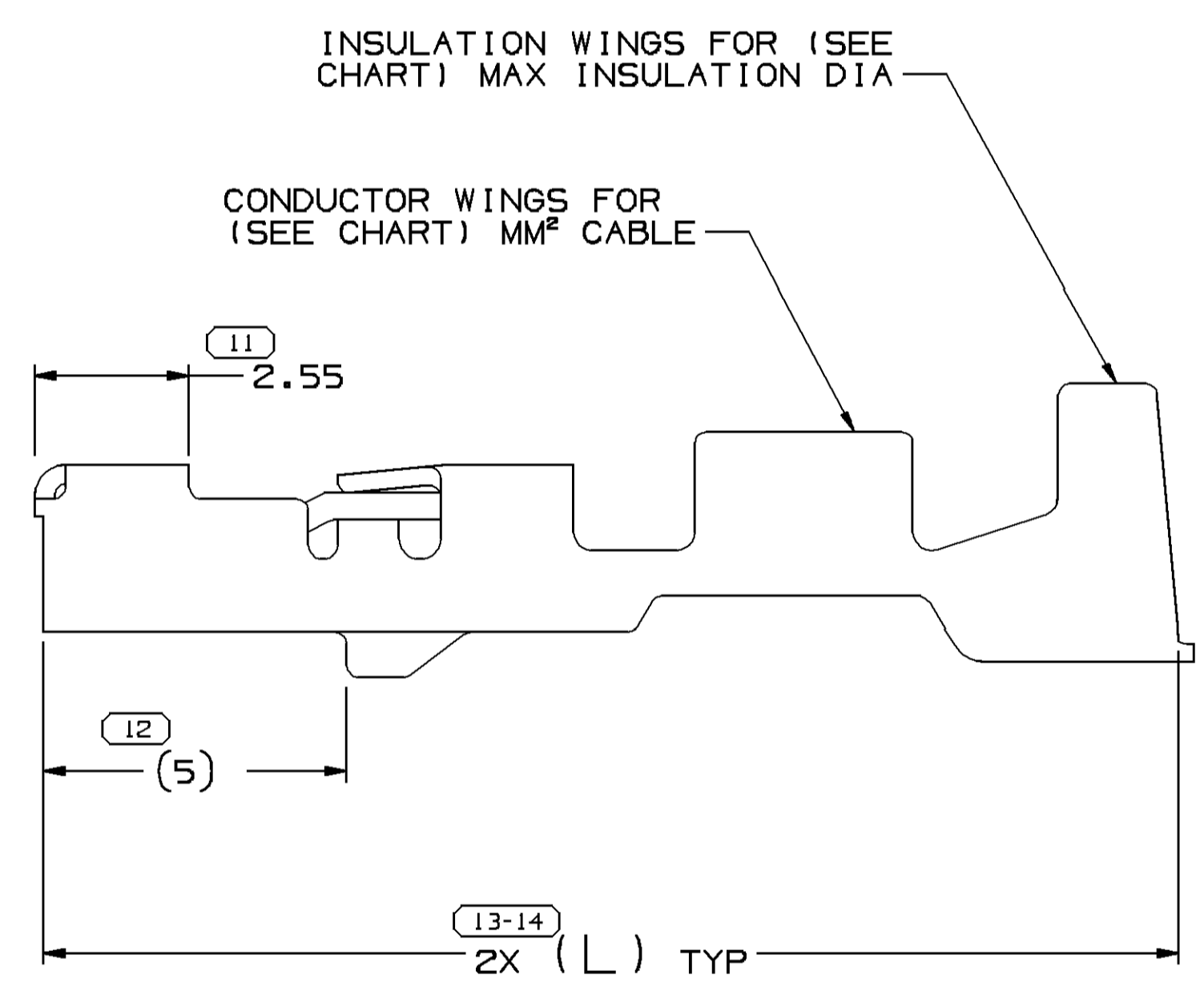
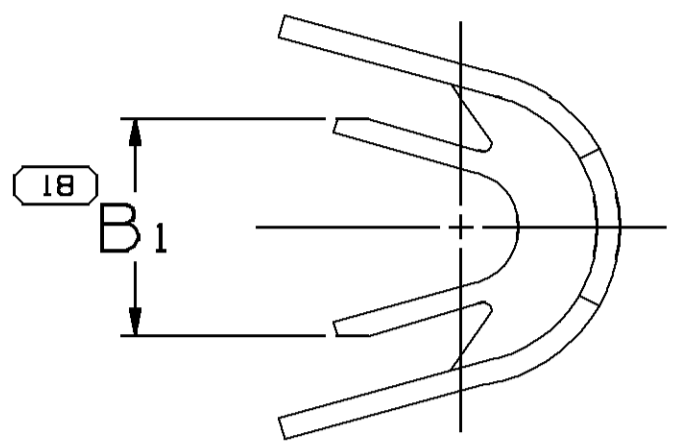
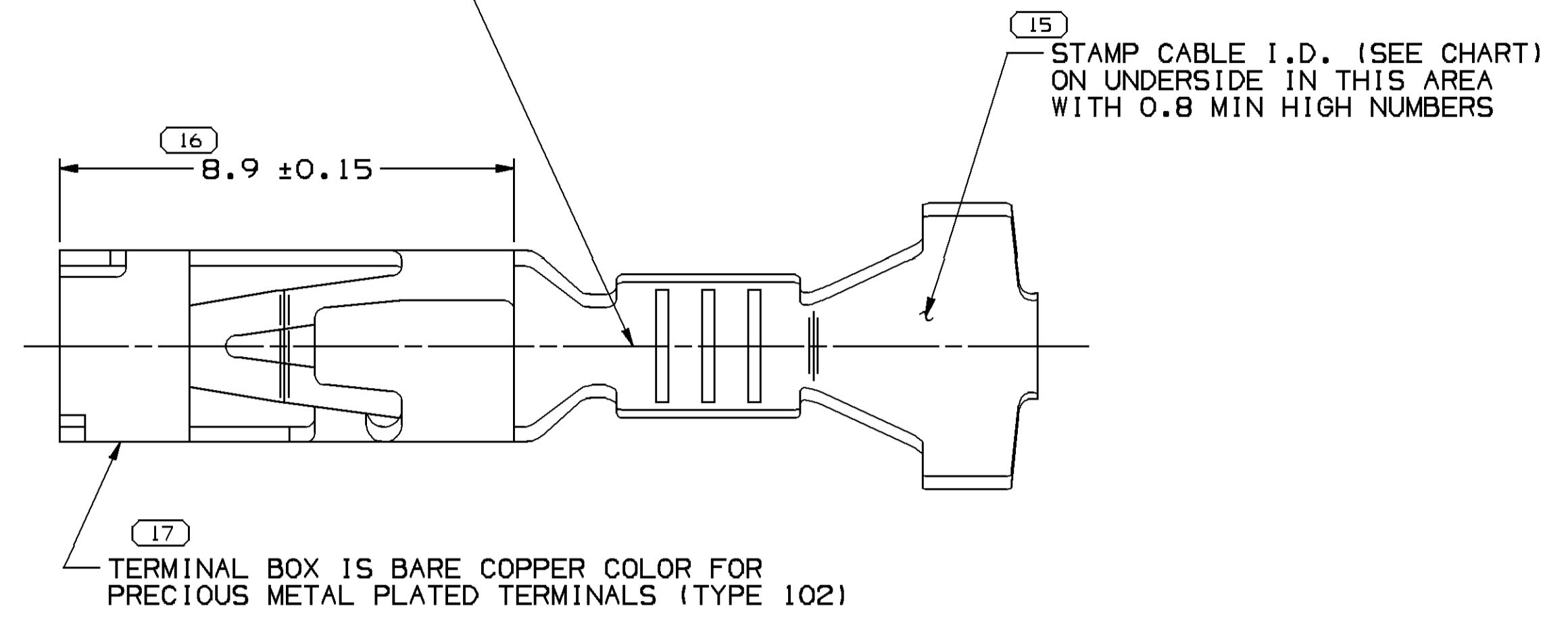

2 RIB SEAL POSITION REF AND TERMINAL & CABLE ALIGNMENT SCALE 5:1

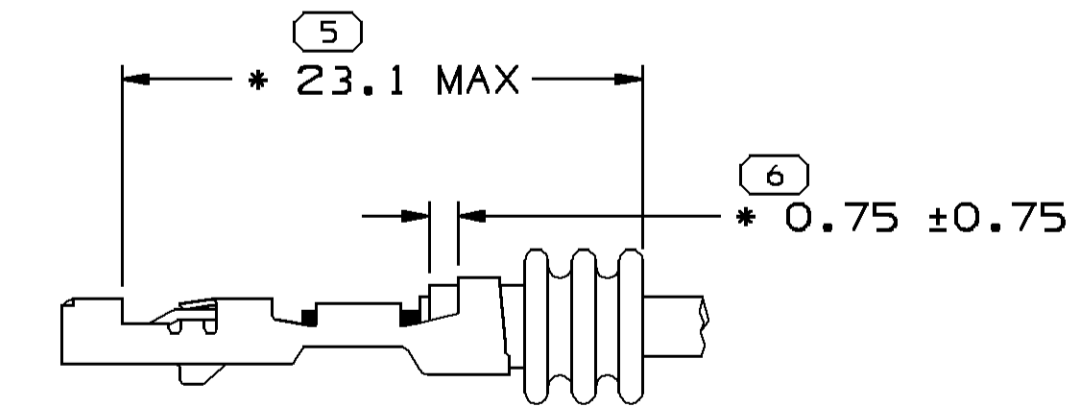

3 RIB SEAL POSITION REF SCALE 5:1

- NOTES
- UNLESS OTHERWISE SPECIFIED AND/OR INDICATED: DIMENSIONS ARE TO FACE OF VIEW SHOWN AND AUTOMATICALLY ROUNDED BY COMPUTER FOR INSPECTION (SEE MATH MODEL FOR PRECISE DIMENSIONS). FOR ALL OTHER DIMENSIONS NOT SHOWN BUT REQUIRED FOR TOOL BUILD, SEE MATH MODEL FOR PRECISE TOOL PATH DATA.
 - FOR PRECIOUS METAL PLATED TERMINALS (TYPE 102), MATING TERMINAL MUST HAVE A PRECIOUS METAL (GOLD TO GOLD) CONTACT INTERFACE.
 - "*" DENOTES DIMENSIONS MADE AT CUT-OFF AND CRIMP DIE.
 - DO NOT PROBE, TEST OR OTHERWISE CONTACT THE INTERIOR REGION (THE SPRING OR ANY MOVING PART) OF THIS TERMINAL. SEVERE DAMAGE CAN OCCUR, COMPROMISING THE PERFORMANCE OF THE ELECTRICAL INTERFACE.

PART NO	REV	N/P	STATUS	MAT'L SIZE	PLATED	MATERIAL SPEC	SIZE MM²	I.D. CABLE	DIA	TYPE	B ₁ ±0.2 (L)	TYPICAL CABLE SEAL	TYPICAL SEALING CAVITY CONFIG	
13528779	01	AA		0.3 X 27.38		M3669A23 C17410 1/2 HD	2 - 3	13	3.2 - 2.5	102	3.75	18.9	15366067 OR EQUIVALENT	5.8 DIA ROUND
15491972	01	AB		0.3 X 27.38		M3666CN7 17410 BECU 1/2 HT AU CLD SN STR	0.75-1	17	2.25-1.7	102	2.65	18.9	15366066 OR EQUIVALENT	5.8 DIA ROUND
15392777	01	AH		0.3 X 27.38		M3666CN7 (C17410 ALLOY W/DGR INLAY)	4 - 5	10	3.9 - 3.4	102	4.8	18.9	12191235 OR EQUIVALENT	5.8 DIA ROUND
15401195	01	AH		0.3 X 27.38		M3666CN7 17410 BECU 1/2 HT AU CLD SN STR	0.35-0.5	21	1.85-1.2	102	2.1	18.9	15366065 OR EQUIVALENT	5.8 DIA ROUND
15366684	01	AK		0.3 X 27.38		M3666CN7 17410 BECU 1/2 HT AU CLD SN STR	2 - 3	13	3.2 - 2.5	102	3.75	18.9	15366067 OR EQUIVALENT	5.8 DIA ROUND
15326004	D9	-		0.3 X 27.38		M3669A23 C17410 1/2 HD	4 - 5	10	3.9 - 3.4	101	4.8	18.9	12191235 OR EQUIVALENT	5.8 DIA ROUND

(3) PROCESS SENSITIVE DIMENSION	
DIMENSIONS ENCLOSED IN () INDICATE REFERENCE DIMENSIONS AND NO TOLERANCE LIMITS ARE ESTABLISHED	CHART ID
DIMENSIONAL RANGE (MM)	>12
FROM 0 TO 12	>12
TOLERANCE UNLESS OTHERWISE SPECIFIED	±0.1
ANGULAR TOLERANCE 22°	±0.2

PART DRAWING	
STYLE	DISTR CODE
VOLUME 10/1	D
UNLESS OTHERWISE SPECIFIED	
THIS DOCUMENT IS IN ACCORDANCE WITH ASME Y14.9M-1994 AS MODIFIED BY THE MDCS DIMENSIONING AND TOLERANCE MANUAL (REV. 1997). ALL DIMENSIONS AND RELATED DATUMS APPLY UNLESS OTHERWISE SPECIFIED. DIMENSIONS NOT SHOWN BUT REQUIRED FOR TOOL BUILD ARE ESTABLISHED BY QUANTIFICATION OR LOCATION TOLERANCES. SURFACE FINISH CALLOUTS MAY BE SHOWN SEPARATELY. UNLESS OTHERWISE SPECIFIED, ALL DIMENSIONS ARE IN MILLIMETERS.	
THIRD ANGLE PROJECTION	DO NOT SCALE
USE MATH DATA	UNIMAPHIS

DELPHI
DELPHI PACKARD ELECTRIC SYSTEMS
WREN, OH

DR	DATE
APV01 H. CASTRILLON	11MR97
APV02 R. RAMOS S.	11MR97
APV03 B. EDWARDS	11MR97
APV04	
APV05	

SUBSTANCES OF CONCERN AND RECYCLED CONTENT PER DELPHI 10949001

MASTER/AL SEE CHART

DRAWING NAME
TAXI TERM F GT 280 SEALED

DRAWING NUMBER
15304714

SIZE	SCALE	FRAME NO	SHEET NO	STG	REV	N/P
A0	10:1	1	2	R	18	-

Mouser Electronics

Authorized Distributor

Click to View Pricing, Inventory, Delivery & Lifecycle Information:

[Aptiv:](#)

[15326004-L](#)